

THE INFORMATION CONTAINED IN THIS DRAWING IS THE SOLE PROPERTY OF YAMAICHI ELECTRONICS DEUTSCHLAND GmbH. ANY REPRODUCTION IN PART OR WHOLE WITHOUT THE WRITTEN PERMISSION OF YAMAICHI ELECTRONICS DEUTSCHLAND GmbH IS PROHIBITED.

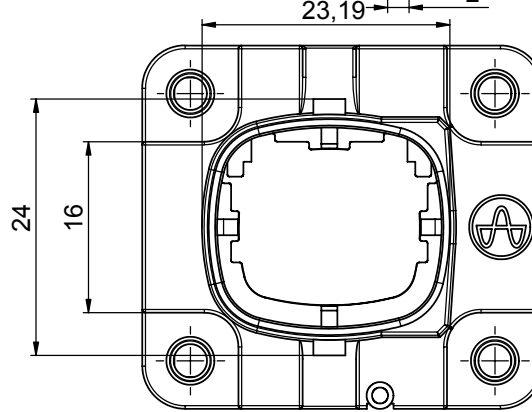

X
Ansicht für Beschreibung
Ausschnitt im Schaltschrank
View for description
of the cut out in the
electrical cabinet

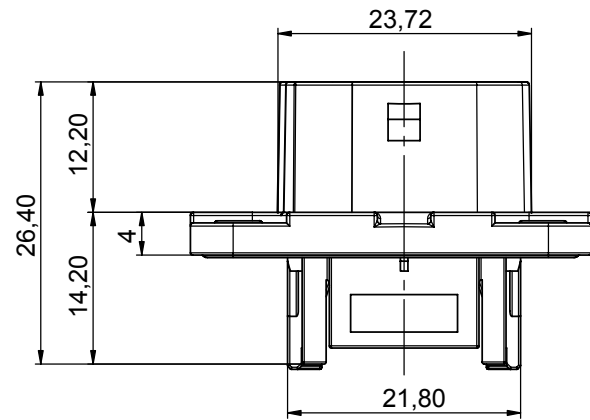
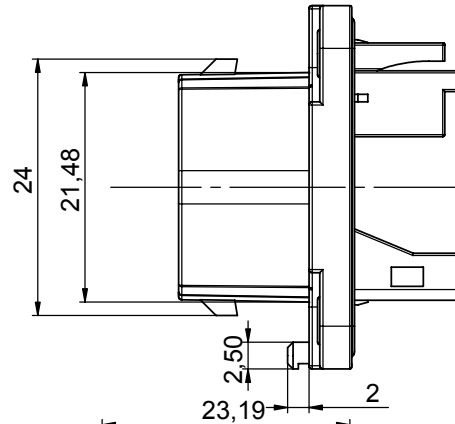
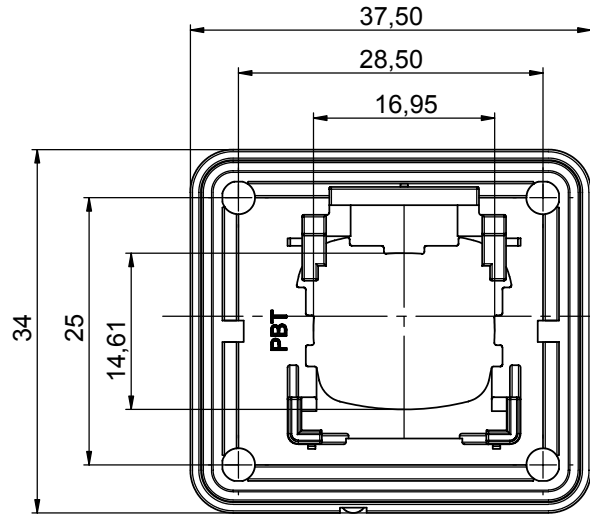
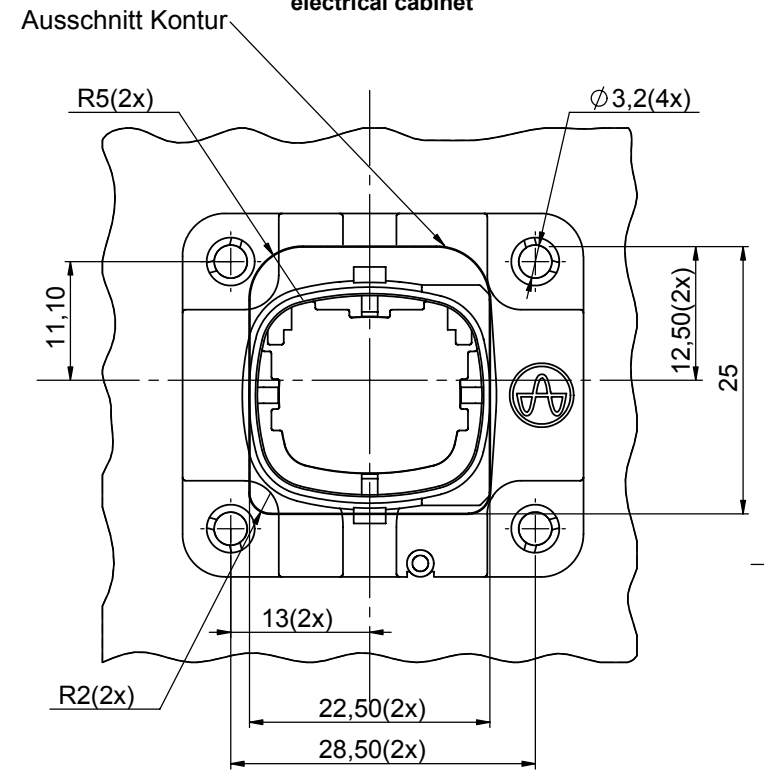

ACHTUNG / ATTENTION :
 - Anzugsdrehmoment max. 0,3-0,4 Nm ! / Mounting torque max. 0,3-0,4 Nm !
 - Keine Unterlegscheibe zw. Schraubenkopf und Flansch verwenden !
 Do not use a washer between screw head and flange !
 - Selbstsichernde Muttern benutzen ! Use only self-locking nuts !

Schraubenspezifikation / Specification of screws :

Linsenschrauben mit Flansch und Innensechskant (Inbus)
 Flange button head socket screws

Empfehlung / Recommendation:
 Fa. Bossard BN 11252
 Fa. Gross Art.Nr. 0303 0307
 Fa. Keller&Kalmbach WN 7381

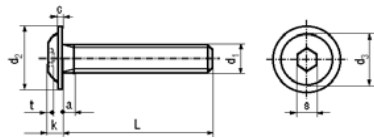

Kopfdurchmesser / screw head diameter (d2) : $\varnothing 6,5 - 7\text{mm}$
 Gewinde / Thread (d1) : M3
 Gewindelänge / Thread length (L) : abhängig von der Wanddicke und Mutter / depends on wallthickness and nut
 Bei 1mm Wanddicke / with 1mm wallthickness : 8mm
 1,65 mm
 je nach Einsatzgebiet / depends on field of application :
 Normal Stahl 4.8 oder Stahl rostbeständig A2 / schwarz oder verzinkt
 Normal steel 4.8 or stainless steel A2, black or galvanized

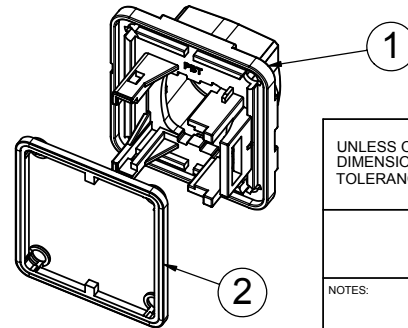

ITEM NO	DESCRIPTION	MATERIAL	UL-Listing
1	Motorflange	PBT blue	UL94V-0
2	Seal	TPE black	UL94V-HB

UNLESS OTHERWISE SPECIFIED:
 DIMENSIONS ARE IN MILLIMETERS
 TOLERANCES: $\pm 0,2$

REV.	REVISION DESCRIPTION	INITIALS	REV. DATE
5			
4			
3			
2			
1			



DO NOT SCALE DRAWING		CLASSIFICATION:	
DESIGN	NAME	DATE	Customer-drawing
DRAWN			TITLE: Y-ConFlange-10 Mounting flange with integrated 2C seal
CHECKED			DWG. NO.: Customer-P(090)A60
ANGLE PROJECTION:	First	Q.A.	REV. ORIGIN REV. D 2
APPROVED			SHEET 1 OF 1 A3 - ASSEMBLY

Mouser Electronics

Authorized Distributor

Click to View Pricing, Inventory, Delivery & Lifecycle Information:

[Yamaichi Electronics:](#)

[Y-ConFlange-10](#)