

THIS DRAWING IS UNPUBLISHED. RELEASED FOR PUBLICATION
 © COPYRIGHT - By - ALL RIGHTS RESERVED.

LOC		DIST		REVISIONS			
P	LTR	DESCRIPTION		DATE	DWN	APVD	
AF	50	A1	REVISED PER ECR-19-014370		30SEP2019	JA	PKS

- 1 CONTINUOUS STRIP ON REELS WITH TERMINALS LOCATED ON 13.97±0.08 [.550±.003] CENTERS.
- 2 SLOT ACCEPTS 0.45-0.64mm [#25-#22] AWG COPPER MAGNET WIRE OR 0.57-0.72mm [#23-#21] AWG ALUMINUM MAGNET WIRE. TWO WIRES OF THE SAME SIZE PER SLOT EXCEPT 0.64-0.72mm [#22-#21] AWG WHICH IS ONE WIRE ONLY. ALUMINIUM WIRE RANGE APPLIES FOR POST TIN PLATED PARTS ONLY.

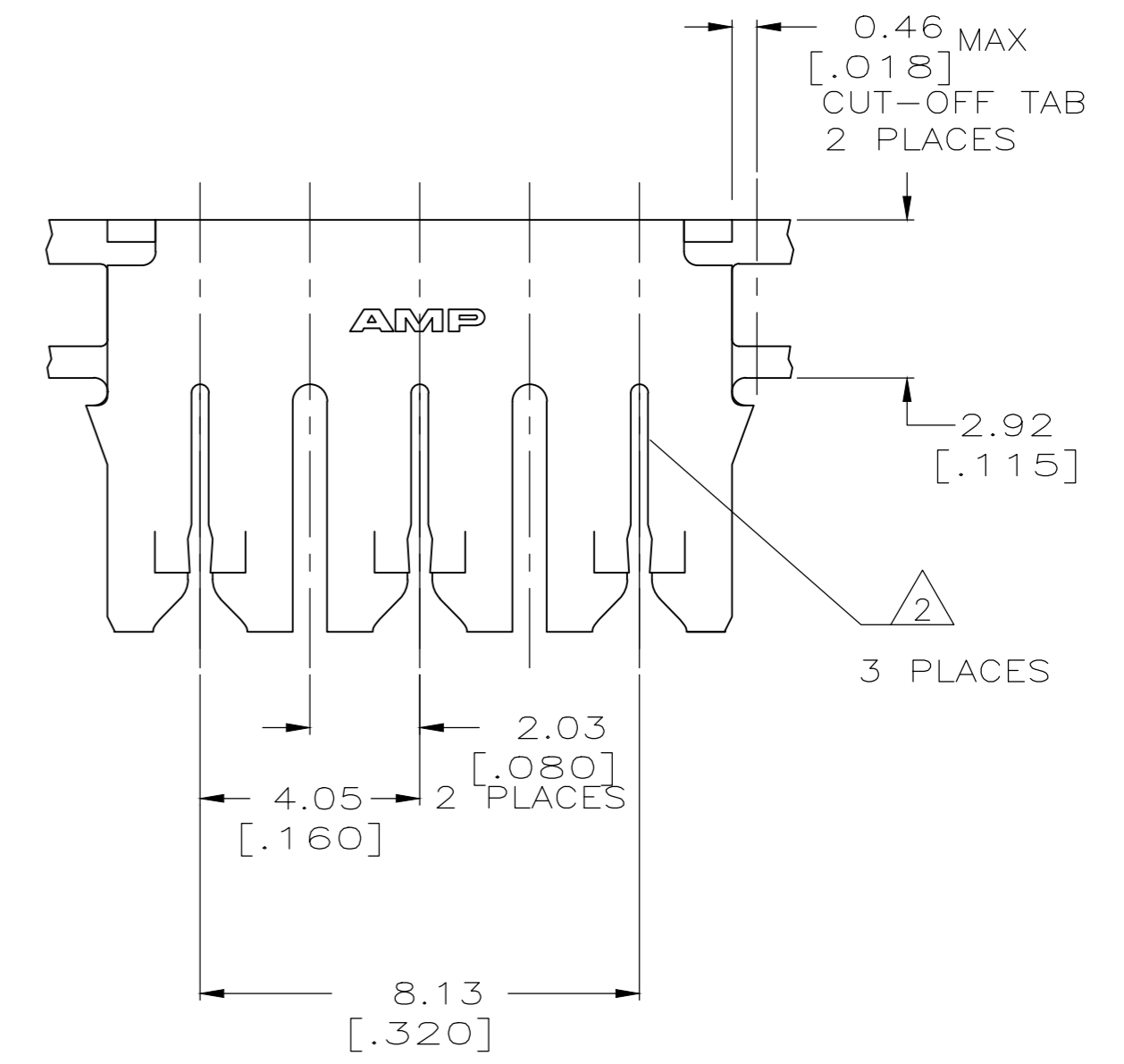
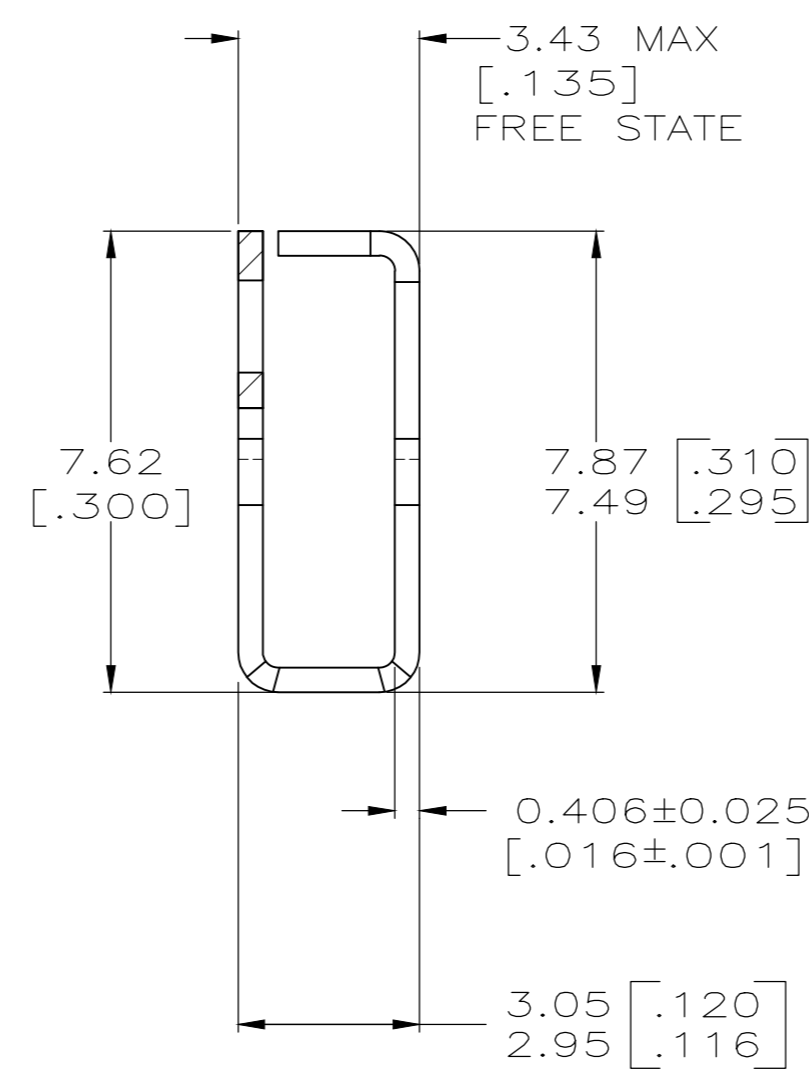
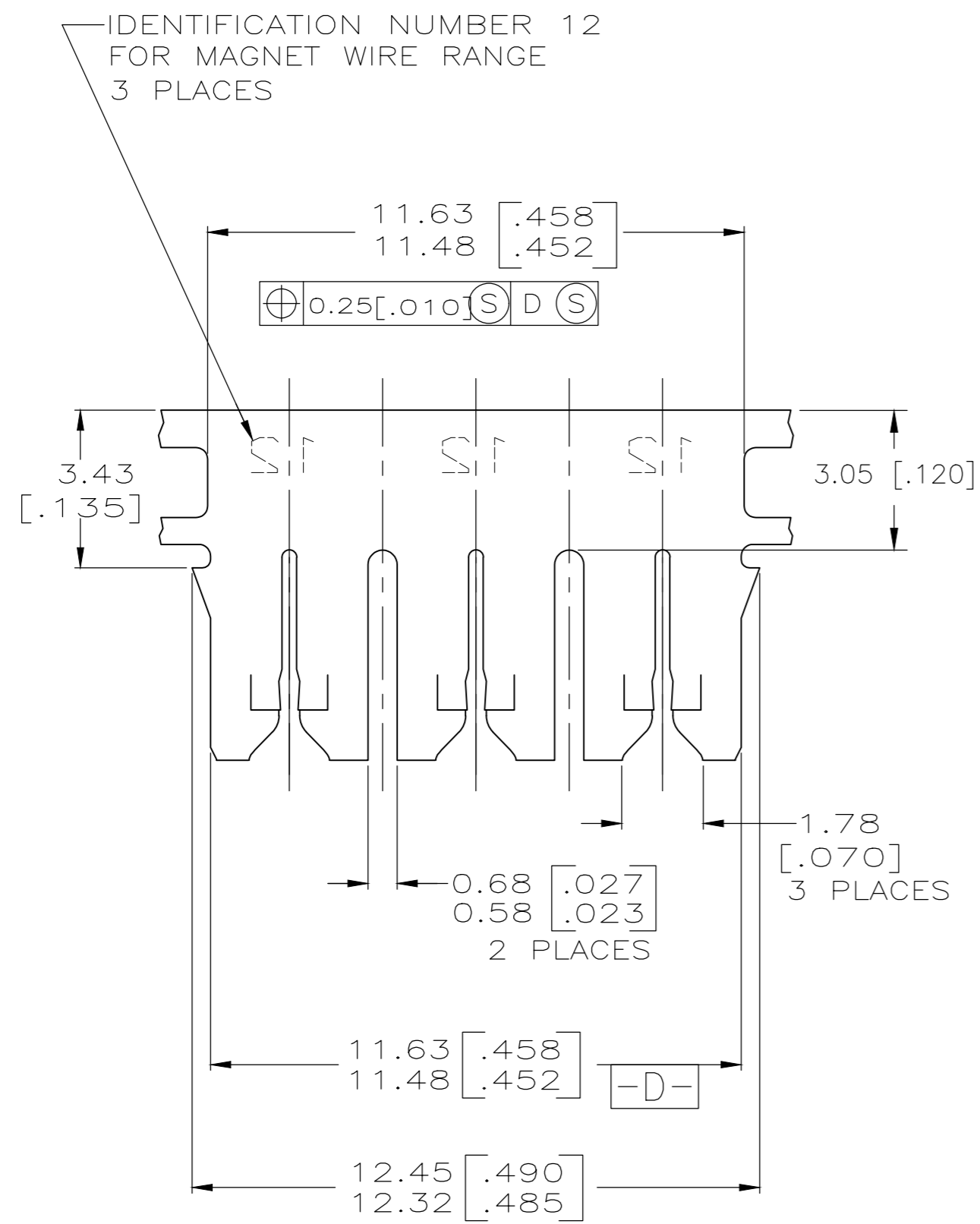
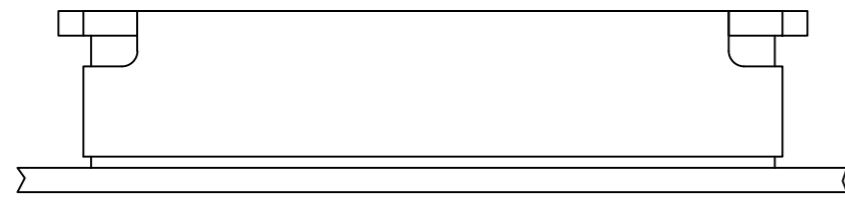

2238069-1
PART NUMBER

THIS DRAWING IS A CONTROLLED DOCUMENT.		DWN	JR RUTH	21NOV14	 TE Connectivity	NAME		TERMINAL, SPLICE, TRI-SLOT, 300 SERIES MAG-MATE™		
DIMENSIONS: mm [INCHES]		CHK	KURT A. RANDOLPH	21NOV14		PRODUCT SPEC		108-2012	SIZE	CAGE CODE
TOLERANCES UNLESS OTHERWISE SPECIFIED:		APVD	KURT A. RANDOLPH	21NOV14		APPLICATION SPEC		114-2046	SCALE	SHEET
0 PLC ± - 1 PLC ± - 2 PLC ± 0.25[.010] 3 PLC ± - 4 PLC ± - ANGLES ± -		MATERIAL	FINISH	WEIGHT		DRAWING NO		RESTRICTED TO	SCALE	SHEET
		BRASS	TIN PLATE	-	114-2046		-	8:1	1 of 1	
		CUSTOMER DRAWING		A2 00779 C=2238069		REV		A1		