

General Description

The Sanrise SRC65R108BS is a high voltage power MOSFET, fabricated using advanced super junction technology. The resulting device has extremely low on resistance, low gate charge and fast switching time, making it especially suitable for applications which require superior power density and outstanding efficiency.

The SRC65R108BS break down voltage is 650V and it has a high rugged avalanche characteristics. The SRC65R108BS is available in TO-247, TO-220C, TO-263-2 and TO-220F packages.

Features

- Ultra Low $R_{DS(ON)} = 108m\Omega @ V_{GS} = 10V$.
- $V_{ds@T_{jmax}} = 650V$.
- Ultra Low Gate Charge, $Q_g = 81nC$ typ.
- Intrinsic Fast-Recovery Body Diode
- Fast switching capability
- Robust design with better EAS performance
- Non-automotive Qualified
- Ultra-fast body diode

Application

- Server/ Telecom Power

Symbol

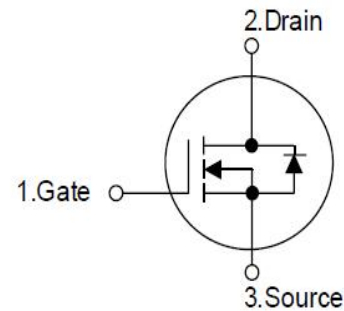

Figure 1 Symbol of SRC65R108BS

Package Type

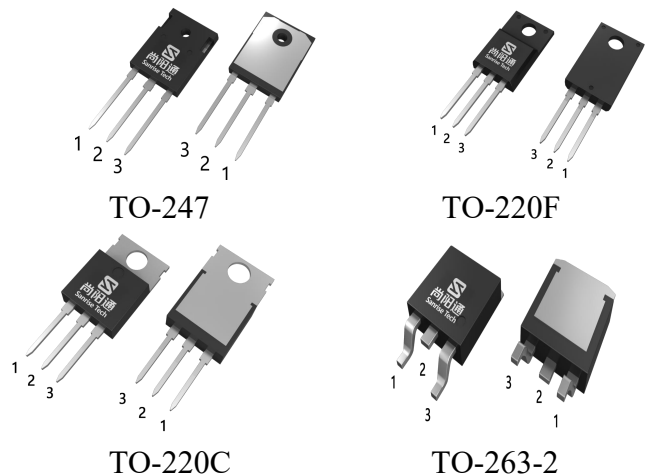

Figure 2 Package Types of SRC65R108BS

Ordering Information

	SRC65R108BS□□-□	
Circuit Type	_____	E: Lead Free
Package	_____	G: Green
T: TO-247		Blank: Tube
TF: TO-220F		TR: Tape & Reel
TC: TO-220C		
S2: TO-263-2		

Package	Part Number	Marking ID	Packing Type
TO-247	SRC65R108BST-G	SRC65R108BSTG	Tube
TO-220F	SRC65R108BSTF-G	SRC65R108BSTFG	Tube
TO-220C	SRC65R108BSTC-G	SRC65R108BSTCG	Tube
TO-263-2	SRC65R108BSS2TR-G	SRC65R108BSS2G	Tape & Reel

Absolute Maximum Ratings^{Note 1}

Parameter	Symbol	Rating	Unit
Drain-Source Voltage	V_{DSS}	650	V
Gate-Source Voltage (static)	V_{GSS}	±20	V
Gate-Source Voltage (dynamic), AC ($f > 1$ Hz)	V_{GSS}	±30	V
Power Dissipation($T_C=25^{\circ}C, TO-220C, TO-247, TO-263-2$)	P_{tot}	231	W
Power Dissipation($T_C=25^{\circ}C, TO-220F$)	P_{tot}	31	W
Continuous Drain Current	I_D	$T_C=25^{\circ}C$	30
		$T_C=100^{\circ}C$	19
		$T_C=125^{\circ}C$	13
Pulsed Drain Current (Note 2)	I_{DM}	90	A
Avalanche Energy, Single Pulse (Note 3)	E_{AS}	135	mJ
Avalanche Energy, Single Pulse (Note 4)	E_{AS}	1166	mJ
Avalanche Energy, Repetitive (Note 2)	E_{AR}	0.4	mJ
Avalanche Current, Repetitive (Note 2)	I_{AR}	3.0	A
Continuous Diode Forward Current	I_S	30	A
Diode Pulse Current	$I_{S,PULSE}$	90	A
MOSFET dv/dt Ruggedness, $V_{DS} \leq 480V$	dv/dt	80	V/ns
Reverse Diode dv/dt, $V_{DS} \leq 480V, I_{SD} \leq I_D$	dv/dt	50	V/ns
Operating Junction Temperature	T_J	150	°C
Storage Temperature	T_{STG}	-55 to 150	°C
Lead Temperature (Soldering, 10 sec)	T_{LEAD}	260	°C

Note:

- Absolute maximum ratings are those values beyond which the device could be permanently damaged. Absolute maximum ratings are stress ratings only and functional device operation is not implied.
- Repetitive Rating: Pulse width limited by maximum junction temperature
- $I_{AS} = 2.0A, V_{DD} = 60V, R_G = 25\Omega$, Starting $T_J = 25^{\circ}C$. Finish goods test condition.
- $I_{AS} = 5.88A, V_{DD} = 60V, R_G = 25\Omega$, Starting $T_J = 25^{\circ}C$. Typical Eas.

Thermal characteristics

Parameter	Symbol	Min	Typ	Max	Unit
Thermal resistance, Junction-to-Case	R_{thJC}			4.0	°C /W
				0.54	
				0.54	
				0.54	
Thermal resistance, Junction-to-Ambient	R_{thJA}			81	°C /W
				65	
				65	
				65	

Electrical Characteristics
 $T_J = 25^\circ\text{C}$, unless otherwise specified.

Parameter	Symbol	Test Conditions	Min	Typ	Max	Unit
Statistic Characteristics						
Drain-Source Breakdown Voltage	BV_{DSS}	$V_{GS}=0V, I_D=250\mu A$	650			V
Zero Gate Voltage Drain Current	I_{DSS}	$V_{DS}=650V, V_{GS}=0V$			10	μA
Gate-Body Leakage Current	Forward	$I_{GSSF}, V_{GS}=30V, V_{DS}=0V$			100	nA
	Reverse	$I_{GSSR}, V_{GS}=-30V, V_{DS}=0V$			-100	
Gate Threshold Voltage	$V_{GS(TH)}$	$V_{DS}=V_{GS}, I_D=0.8mA$	3.5	4.5	5.5	V
Static Drain-Source On-Resistance	$R_{DS(ON)}$	$V_{GS}=10V, I_D=16A$		89	108	mΩ
Gate Resistance	R_G	f=1MHz, Open Drain		1.0		Ω
Dynamic Characteristics						
Input Capacitance	C_{ISS}	$V_{DS}=400V, V_{GS}=0V,$		1914		pF
Output Capacitance	C_{OSS}	f=100KHz		54		
Effective output capacitance, energy related ^{NOTE5}	$C_{O(er)}$	$V_{GS}=0V,$ $V_{DS}=0\dots 480V$		80		pF
Effective output capacitance, time related ^{NOTE6}	$C_{O(tr)}$			630		
Turn-on Delay Time	$t_{d(on)}$	$V_{DD}=400V, I_D=16A$ $R_G=3\Omega, V_{GS}=12V$		37		ns
Rise Time	t_r			19		
Turn-off Delay Time	$t_{d(off)}$			50		
Fall Time	t_f			9		
Gate Charge Characteristics						
Gate to Source Charge	Q_{gs}	$V_{DD}=400V, I_D=16A$ $V_{GS}=0$ to 10V		18		nC
Gate to Drain Charge	Q_{gd}			43		
Gate Charge Total	Q_g			81		
Gate Plateau Voltage	$V_{plateau}$			7.6		V
Reverse Diode Characteristics						
Drain-Source Diode Forward Voltage	V_{SD}	$V_{GS}=0V, I_{SD}=16A$		0.9	1.1	V
Reverse Recovery Time	t_{rr}	$V_R=400V, I_F=16A$ $dI_F/dt=100A/\mu s$		156		ns
Reverse Recovery Charge	Q_{rr}			1.86		μC
Peak Reverse Recovery Current	I_{rrm}			20		A

Note:

- $C_{O(er)}$ is a fixed capacitance that gives the same stored energy as C_{OSS} while V_{DS} is rising from 0 to 480V
- $C_{O(tr)}$ is a fixed capacitance that gives the same charging time as C_{OSS} while V_{DS} is rising from 0 to 480 V

Typical Performance Characteristics

<p>Figure 3: Power Dissipation</p>  <p>$P_{tot} = f(T_c)$</p>	<p>Figure 4: Max. Transient Thermal Impedance</p>  <p>$Z_{(thJC)} = f(t_p)$; parameter: $D = t_p/T$</p>
<p>Figure 5: Safe Operating Area</p>  <p>$I_D = f(V_{DS})$; $T_c = 25^\circ\text{C}$; $V_{GS} > 7\text{V}$; parameter t_p</p>	<p>Figure 6: Safe Operating Area</p>  <p>$I_D = f(V_{DS})$; $T_c = 80^\circ\text{C}$; $V_{GS} > 7\text{V}$; parameter t_p</p>

Figure 7: Typ. Output Characteristics

 $I_D = f(V_{DS}); T_j = 25^\circ\text{C}; \text{parameter: } V_{GS}$
Figure 8: Typ. Output Characteristics

 $I_D = f(V_{DS}); T_j = 125^\circ\text{C}; \text{parameter: } V_{GS}$
Figure 9: Typ. Drain-Source On-State Resistance

 $R_{DS(ON)} = f(I_D); T_j = 125^\circ\text{C}; \text{parameter: } V_{GS}$
Figure 10: Typ. Drain-Source On-State Resistance

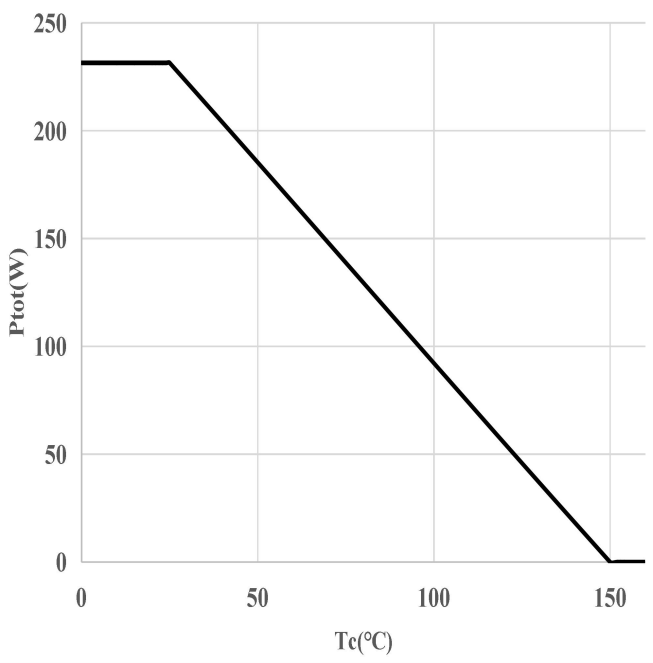
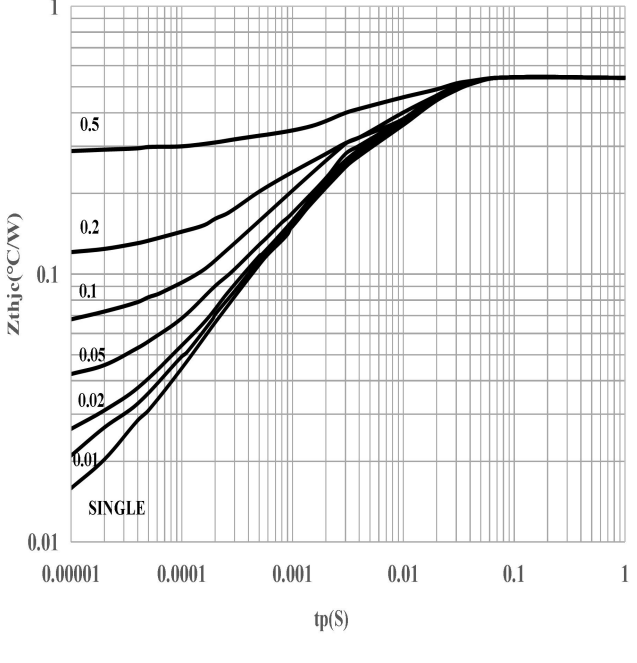
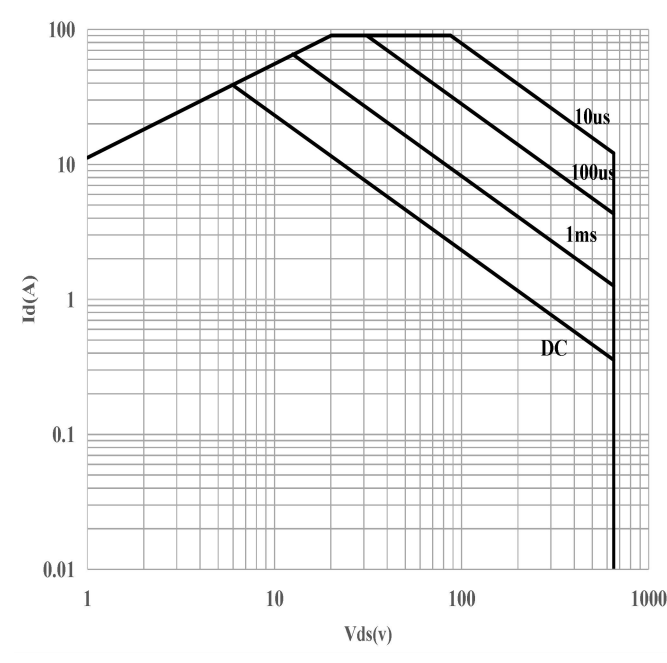
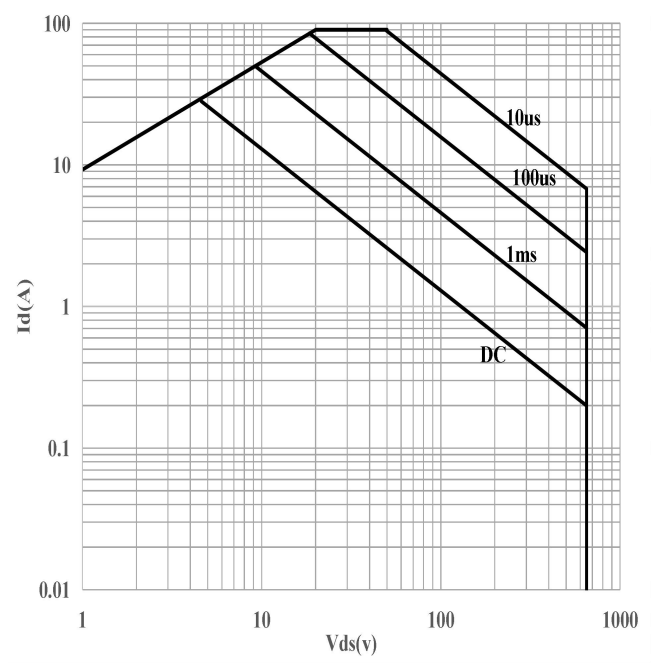
 $R_{DS(ON)} = f(T_j); I_D = 16\text{A}; V_{GS} = 10\text{V}$

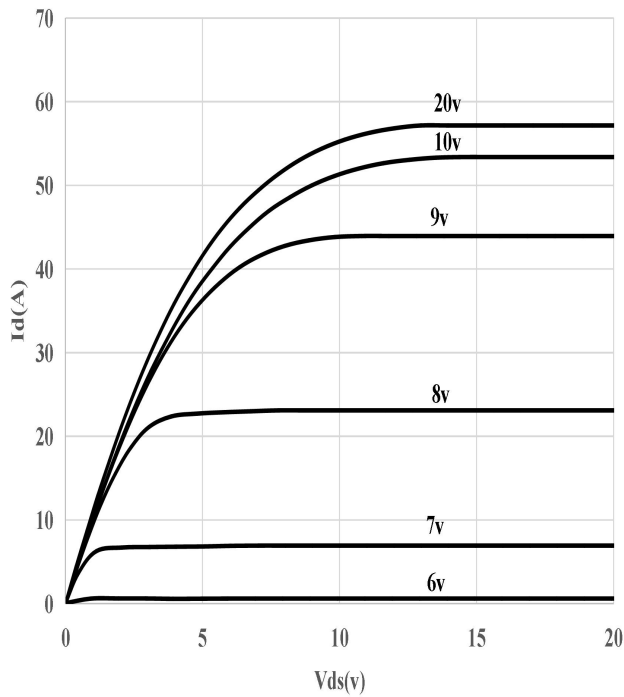
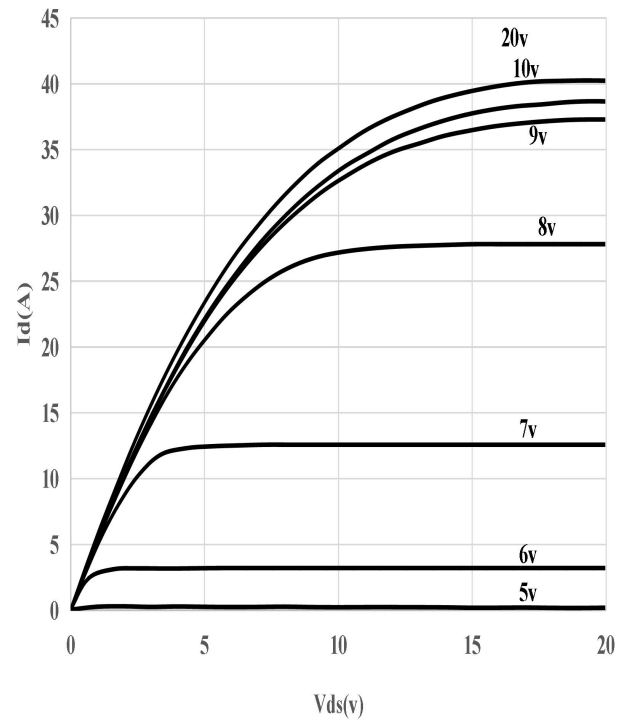
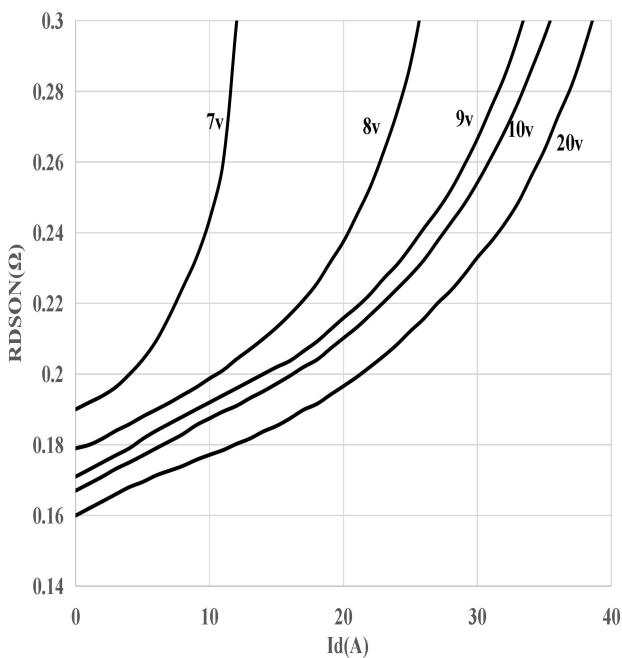
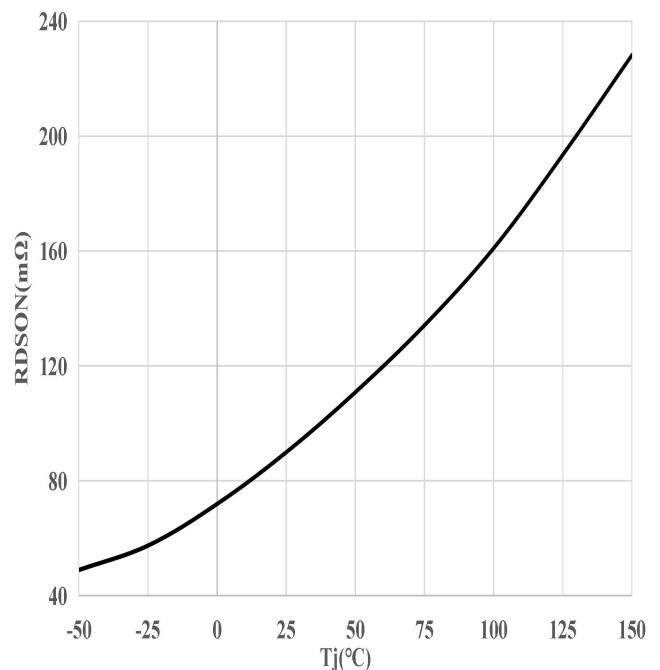
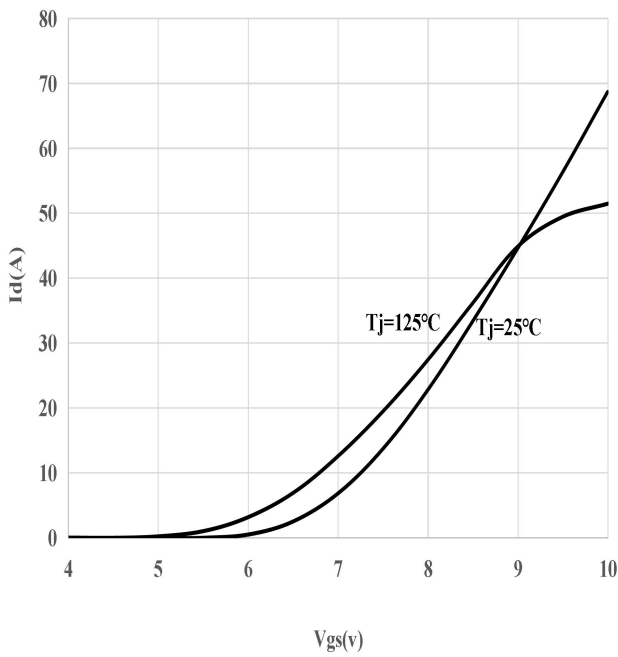
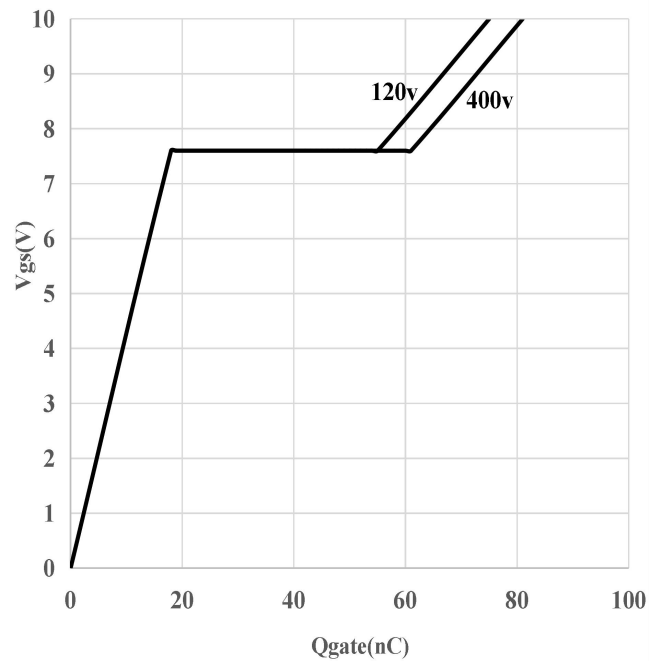
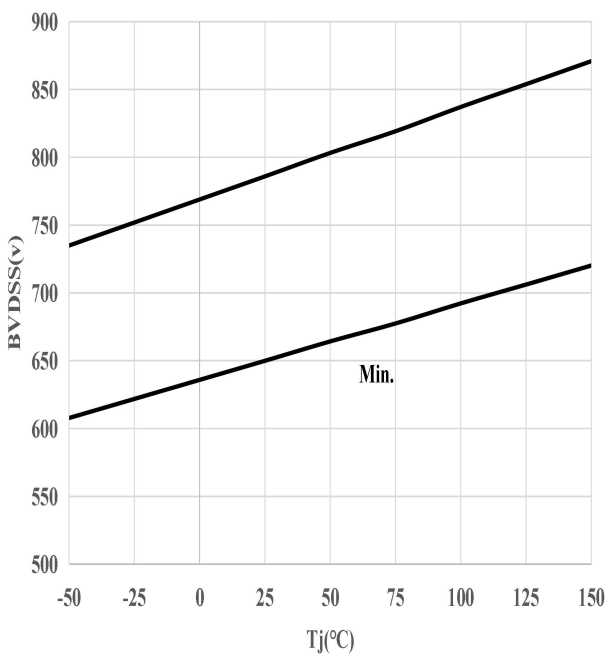
Figure 11: Typ. Transfer Characteristics

$$I_D = f(V_{GS}); V_{DS} = 20V$$

Figure 12: Typ. Gate Charge

$$V_{GS} = f(Q_{gate}), I_D = 16A \text{ pulsed}$$

Figure 13: Drain-Source Breakdown Voltage

$$V_{BR(DSS)} = f(T_j); I_D = 10mA$$

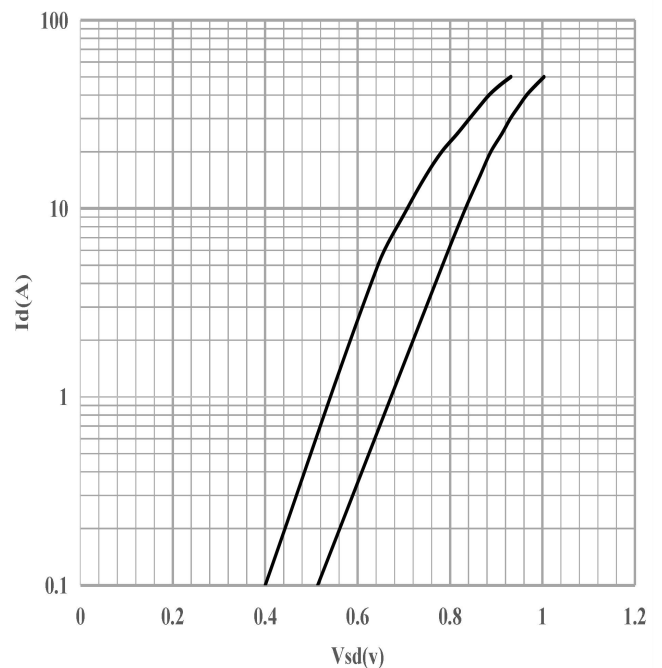
Figure 14: Forward Characteristics of Reverse Diode

$$I_F = f(V_{SD}); \text{parameter: } T_j$$

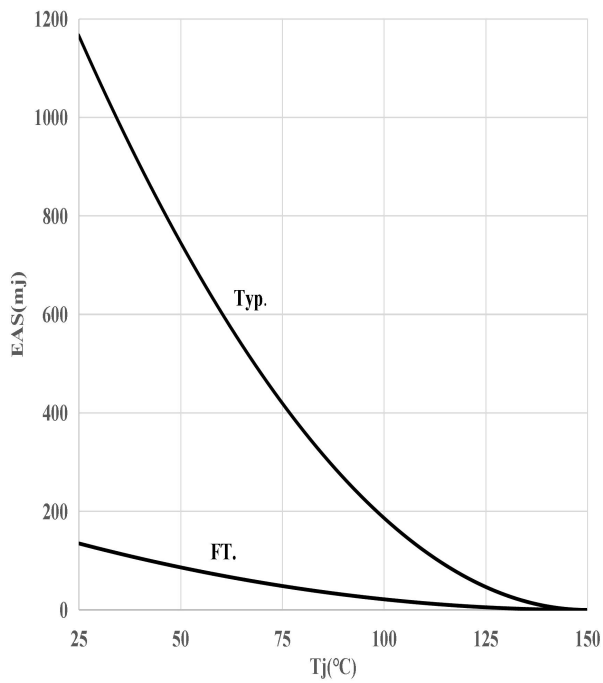
Figure 15: Avalanche Energy

$$E_{AS}=f(T_j); V_{DD}=60V$$

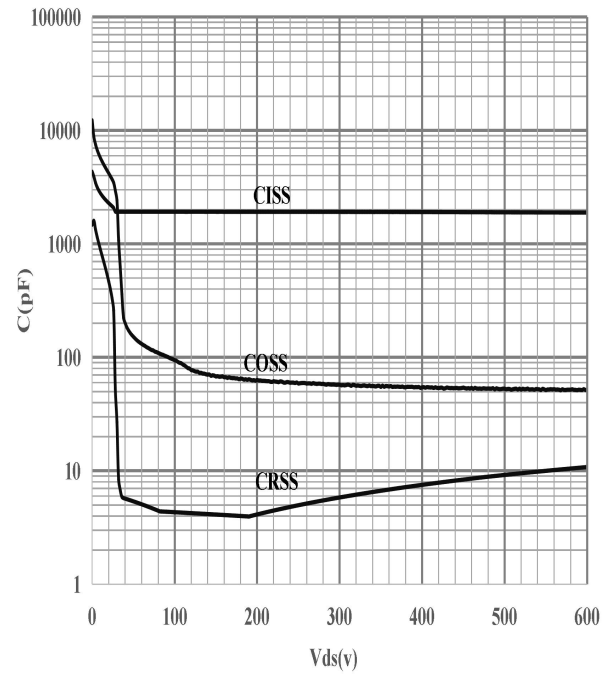
Figure 16: Typ. Capacitances

$$C=f(V_{DS}); V_{GS}=0; f=100KHz$$

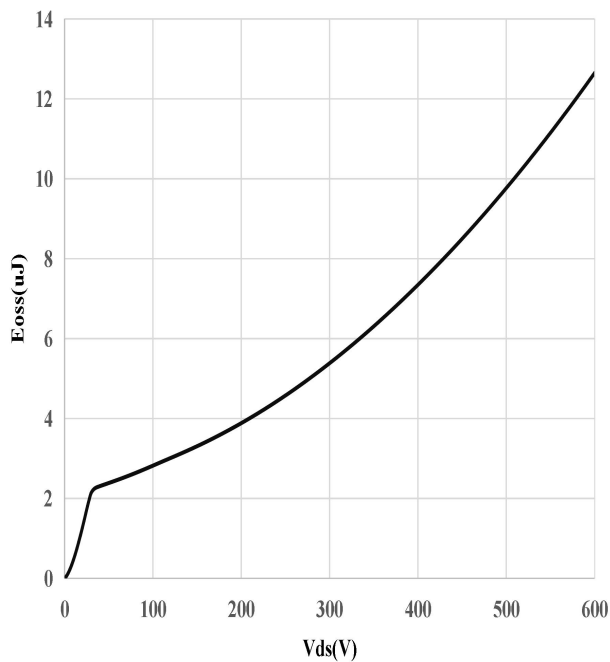
Figure 17: Coss Stored Energy

$$E_{OSS}=f(V_{DS})$$

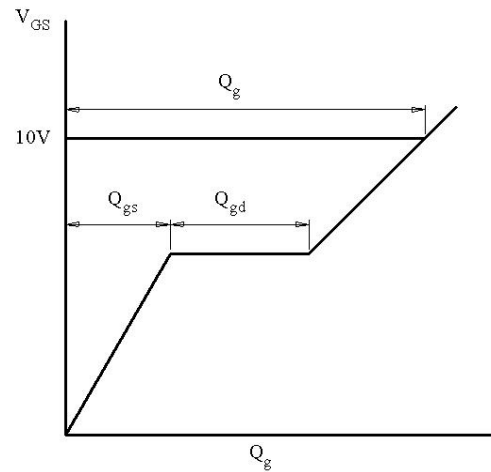
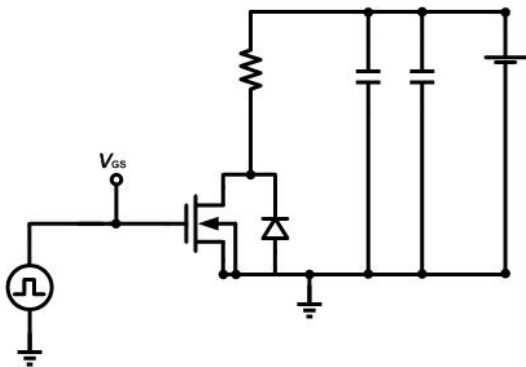
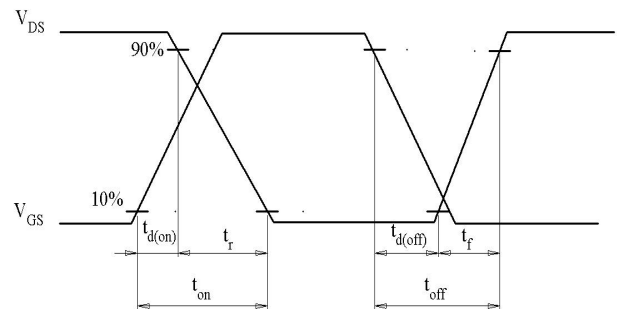
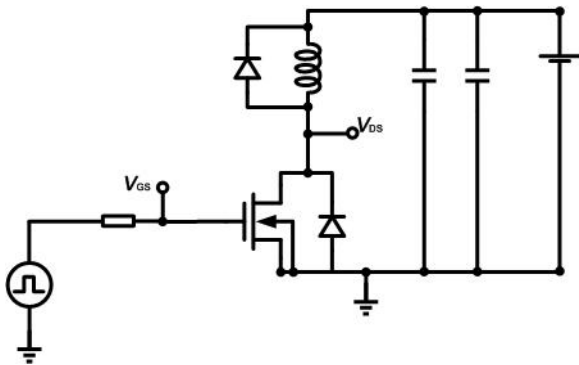
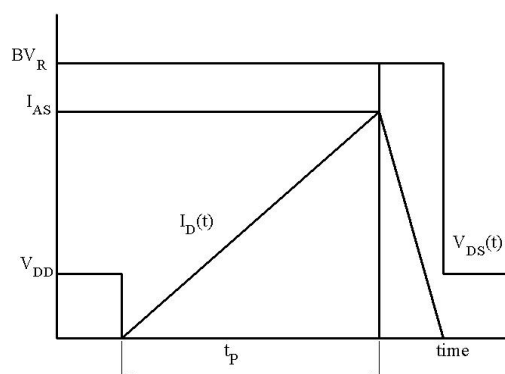
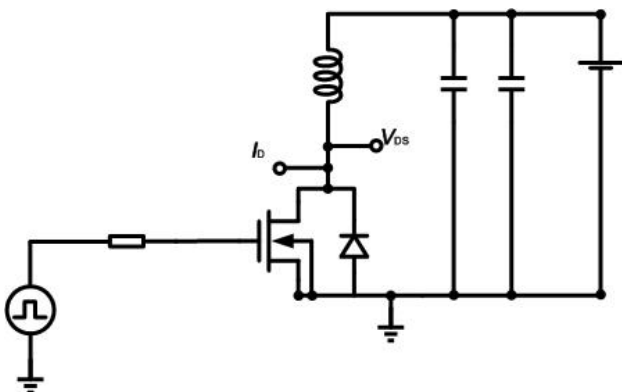
Test Circuits
1. Gate Charge Test Circuit & Waveform

2. Switch Time Test Circuit

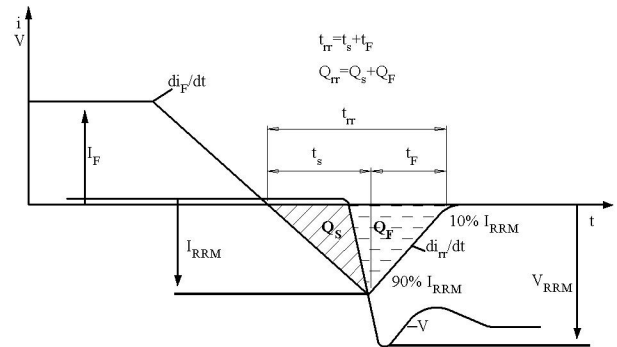
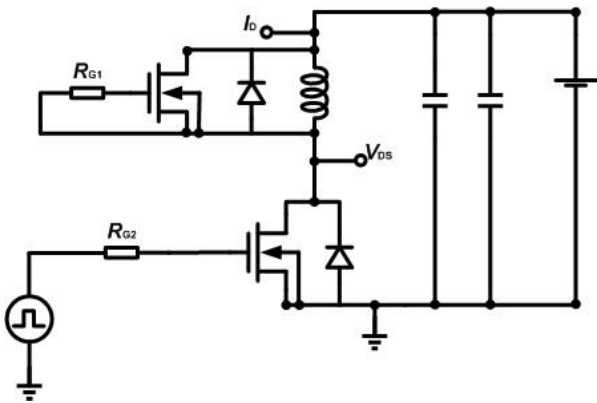
3. Unclaimed Inductive Switching Test Circuit & Waveforms

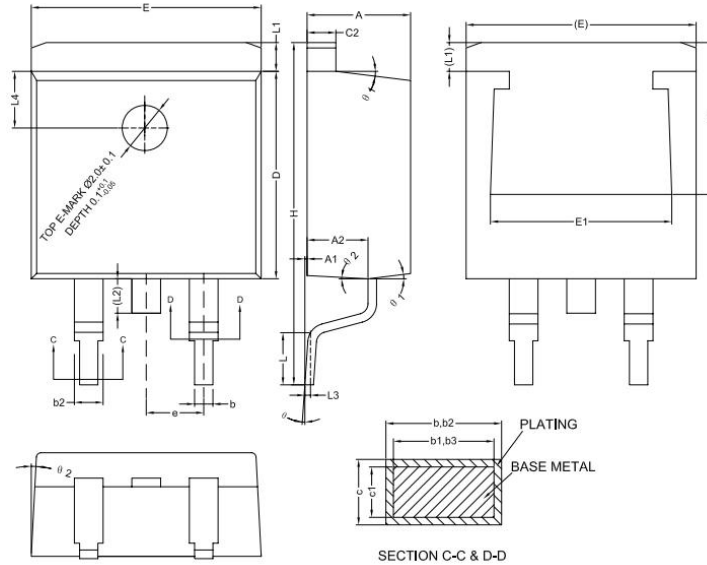
4. Test Circuit and Waveform for Diode Characteristics



Mechanical Dimensions
TO-263-2 (Package 1)
Unit: mm

Symbol	Dimensions(mm)		
	Min.	Typ.	Max.
A	4.40	4.57	4.70
A1	0.00	0.10	0.25
A2	2.59	2.69	2.79
b	0.77	-	0.90
b1	0.76	0.81	0.86
b2	1.23	-	1.36
b3	1.22	1.27	1.32
c	0.34	-	0.47
c1	0.33	0.38	0.43
c2	1.22	-	1.32
D	9.05	9.15	9.25
D1	6.60	-	-
E	10.06	10.16	10.26
E1	7.80	-	8.20
e	2.54(BSC)		
H	14.70	15.10	15.50
L	2.00	2.30	2.60
L1	1.17	1.27	1.40
L2	-	-	1.75
L3	0.25BSC		
L4	2.00REF		
θ	0°	-	8°
θ1	5°	7°	9°
θ2	1°	3°	5°

Mechanical Dimensions
TO-263-2 (Package 2)

Unit: mm

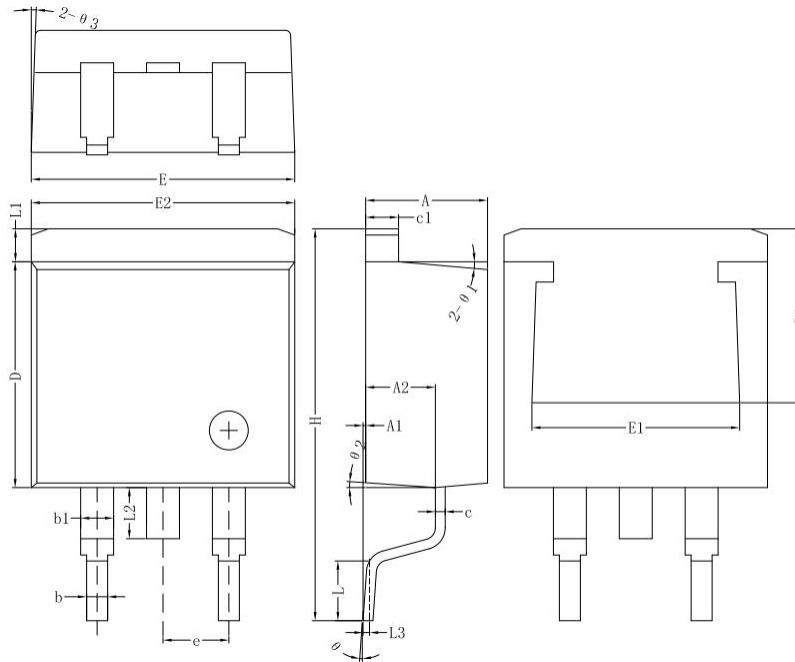

Symbol	Dimensions(mm)		
	Min.	Typ.	Max.
A	4.55	4.70	4.85
A1	0.00	0.10	0.25
A2	2.59	2.69	2.89
b	0.71	0.81	0.96
b1	-	1.27	-
c	0.36	0.38	0.61
c1	1.17	1.27	1.37
D	8.55	8.70	8.85
D1	-	7.2	-
E	10.01	10.16	10.31
E1	-	7.80	-
E2	9.98	10.08	10.18
e	-	2.54	-
H	14.70	15.10	15.50
L	2.00	2.30	2.70
L1	1.17	1.27	1.40
L2	-	-	2.20
L3	-	0.25BSC	-
θ	0°	-	8°
θ ₁		5°	
θ ₂		4°	
θ ₃		4°	

Mechanical Dimensions
TO-263-2 (Package 3)

Unit: mm

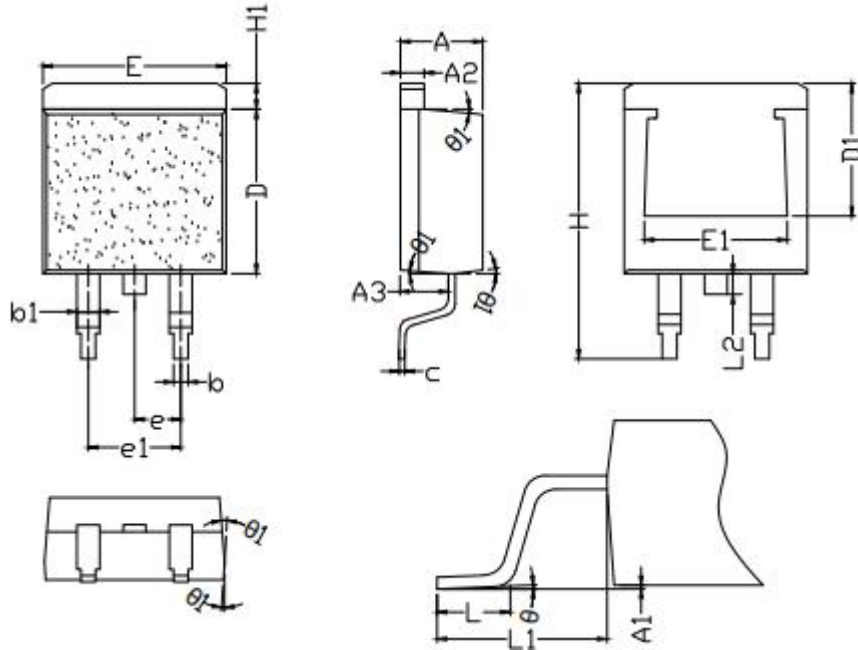

Symbol	Dimensions(mm)		
	Min.	Typ.	Max.
A	4.42	4.52	4.62
A1	0.00	0.10	0.25
A2	1.24	1.27	1.32
A3	2.50	2.60	2.70
b	0.77	0.81	0.84
b1	1.23	1.28	1.41
c	0.33	0.38	0.43
D	8.80	8.95	9.10
D1	7.2REF		
E	9.92	10.07	10.22
E1	7.85REF		
e	2.50	2.54	2.58
e1	5.08REF		
H	14.80	15.10	15.30
H1	1.12	1.28	1.42
L	2.10	2.23	2.36
L1	4.55	4.75	4.95
L2	1.10	1.30	1.50
θ	0°	2°	5°
θ1	3°	-	5°

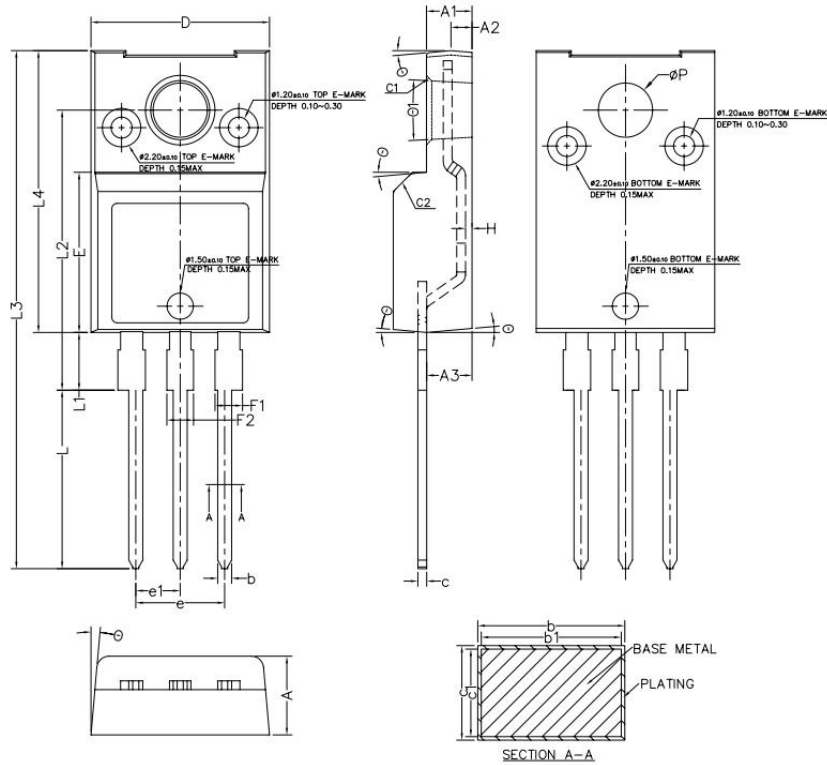
Mechanical Dimensions
TO-220F (Package 1)
Unit: mm

Symbol	Dimensions(mm)		
	Min.	Typ.	Max.
A	4.40	4.50	4.60
A1	2.50	2.60	2.70
A2	1.10	1.20	1.30
A3	2.49	2.59	2.69
b	0.76	-	0.89
b1	0.75	0.80	0.85
c	0.46	-	0.59
c1	0.45	0.50	0.55
C1	0.20	0.30	0.40
C2	1.00	1.10	1.20
D	10.10	10.20	10.30
E	9.05	9.15	9.25
e	4.98	5.08	5.18
e1	2.44	2.54	2.64
F1	1.22	-	1.60
F2	1.17	-	1.55
H	0.32	0.37	0.42
L	10.00	10.20	10.40
L1	3.15	3.30	3.45
L2	15.85	16.00	16.15
L3	29.30	29.60	29.90
L4	16.00	16.10	16.20
P	3.00	3.10	3.20
θ	3°	5°	7°
θ1	4°	6°	8°

Mechanical Dimensions
TO-220F (Package 2)

Unit: mm

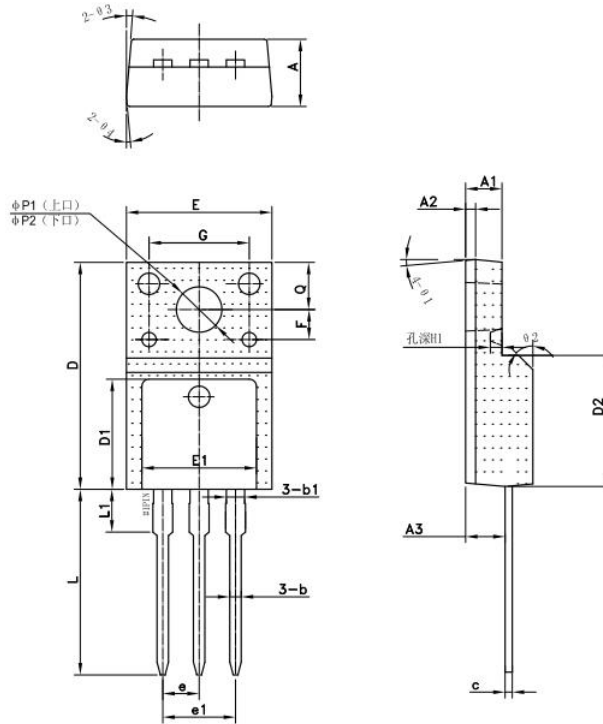

Symbol	Dimensions(mm)		
	Min.	Typ.	Max.
A	4.50	4.70	4.90
A1	2.34	2.54	2.70
A2	-	0.70	-
A3	2.56	2.76	2.96
b	0.70	0.80	0.95
b1	-	1.28	-
c	0.45	0.50	0.65
D	15.67	15.87	16.07
D1	-	7.70	-
D2	-	9.12	-
E	9.96	10.16	10.36
E1	-	8.00	-
e	2.54		
e1	5.08		
F	2.1		
G	7		
H1	-	0.81	-
L	12.48	12.98	13.20
L1	-	2.93	-
ΦP1 (上口)	2.98	3.18	3.38
ΦP2 (下口)	3.20	3.40	3.60
Q	3.10	3.30	3.50
θ1	5°		
θ2	45°		
θ2	5°		
θ3	5°		

Mechanical Dimensions
TO-220F (Package 3)

Unit: mm

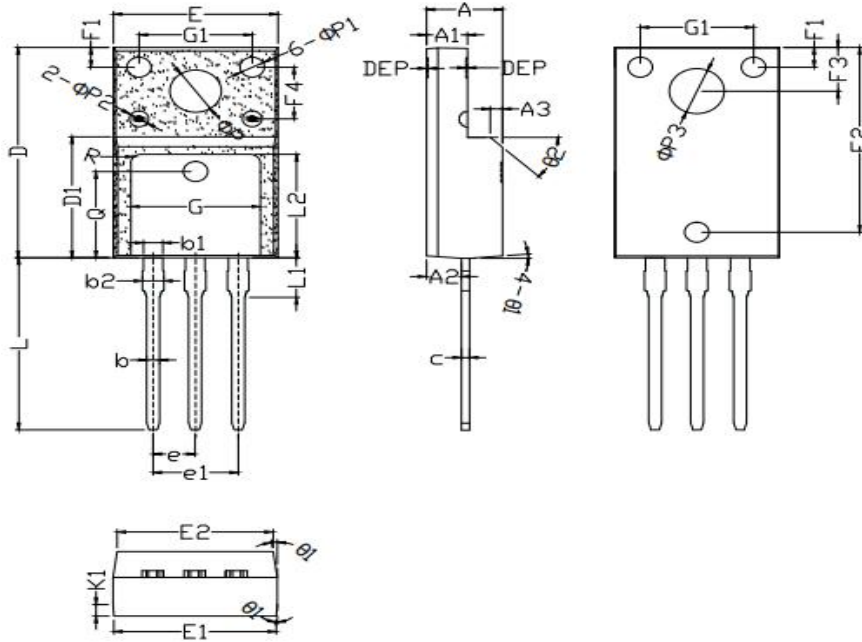

Symbol	Dimensions(mm)		
	Min.	Typ.	Max.
A	4.50	4.70	4.90
A1	2.34	2.54	2.74
A2	2.60	2.80	2.95
A3	1.0REF		
b	0.75	0.80	0.85
b1	1.18	1.20	1.24
b2	1.18	1.24	1.30
c	0.45	0.50	0.55
D	15.67	15.87	16.07
D1	9.04	9.12	9.20
E	10.00	10.16	10.30
E1	9.94	10.06	10.30
E2	9.40	9.50	9.60
e	2.50	2.54	2.58
e1	5.08REF		
L	12.78	12.98	13.18
L1	2.70	2.92	3.20
L2	7.70	7.80	7.90
Q	6.50REF		
ΦP	3.08	3.18	3.28
ΦP1	1.45	1.55	1.65
ΦP2	0.95	1.15	1.35
ΦP3	3.30	3.40	3.50
θ1	3°	5°	7°
θ2	42°	45°	48°
F1	1.40	1.50	1.60
F2	13.80	13.90	14.00
F3	3.20	3.30	3.40
F4	3.70	3.90	4.10
G	7.80	8.00	8.20
G1	6.90	7.00	7.10
K1	0.65	0.70	0.75

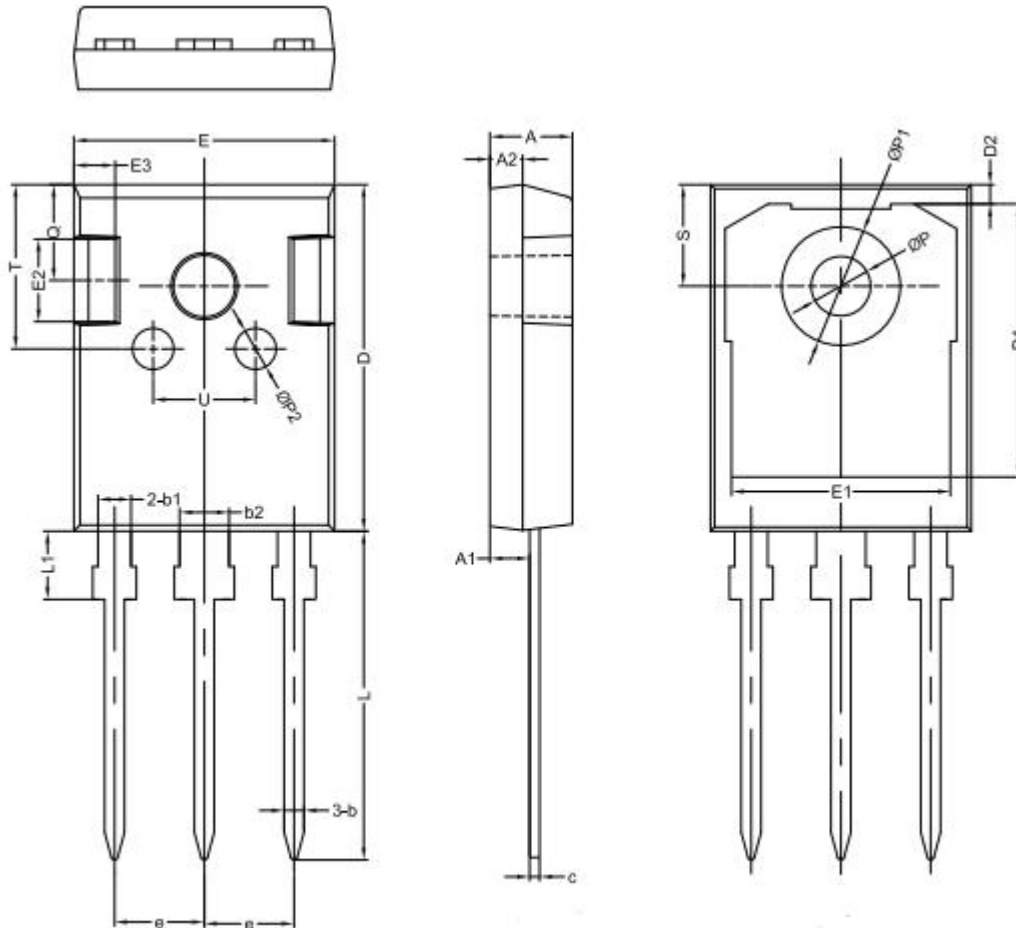
Mechanical Dimensions
TO-247(Package 1)
Unit: mm

Symbol	Dimensions(mm)			Symbol	Dimensions(mm)		
	Min.	Typ.	Max.		Min.	Typ.	Max.
A	4.80	5.00	5.20	E1	-	13.30	-
A1	2.21	2.41	2.61	E2	-	5.00	-
A2	1.90	2.00	2.10	E3	-	2.50	-
b	1.10	1.20	1.35	L	19.42	19.92	20.42
b1	-	2.00	-	L1	-	4.13	-
b2	-	3.00	-	P	3.50	3.60	3.70
c	0.55	0.60	0.75	P1	-	7.19	-
D	20.80	21.00	21.20	P2	-	2.50	-
D1	-	16.55	-	Q	-	5.80	-
D2	-	1.20	-	S	6.05	6.15	6.25
E	15.60	15.80	16.0	T	-	10.00	-
U	-	6.20	-				

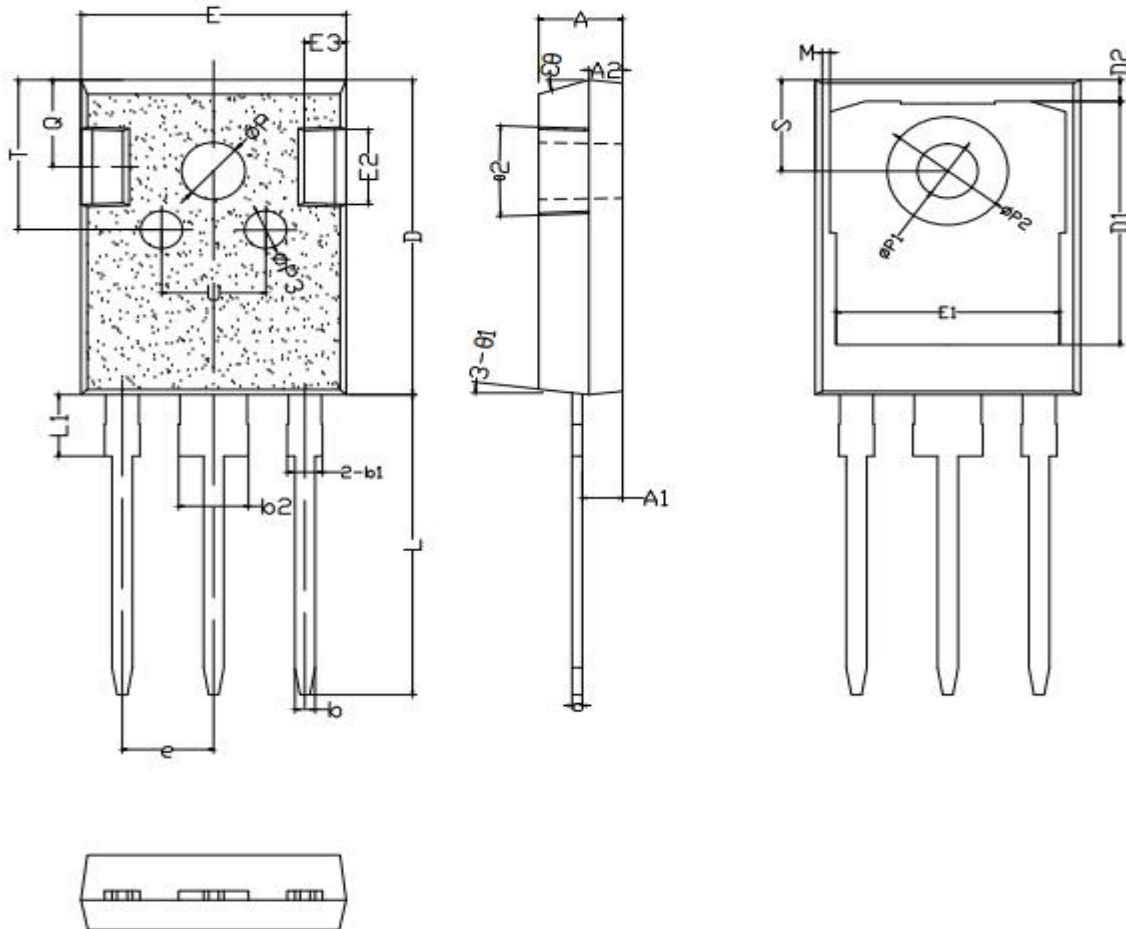
Mechanical Dimensions
TO-247(Package 2)
Unit: mm

Symbol	Dimensions(mm)			Symbol	Dimensions(mm)		
	Min.	Typ.	Max.		Min.	Typ.	Max.
A	4.90	5.00	5.10	E1	13.10	13.25	13.40
A1	2.31	2.41	2.51	E2	4.85	4.95	5.10
A2	1.90	2.00	2.10	E3	2.40	2.50	2.60
b	1.15	1.20	1.25	L	19.80	19.98	20.15
b1	1.95	2.10	2.25	L1	-	-	4.30
b2	2.95	3.10	3.25	ΦP	3.60	3.70	3.80
c	0.55	0.60	0.65	ΦP1	3.40	3.50	3.60
D	20.90	21.00	21.10	ΦP2	6.90	7.10	7.30
D1	16.35	16.55	16.75	Q	5.60	5.80	6.00
D2	1.05	1.20	1.35	S	6.05	6.15	6.25
E	15.70	15.80	15.90	T	9.80	10.00	10.20
U	6.00	6.20	6.40	e	5.40	5.44	5.48
θ1	5°	7°	9°	ΦP3	2.40	2.50	2.60
θ2	1°	3°	5°	θ3	13°	15°	17°

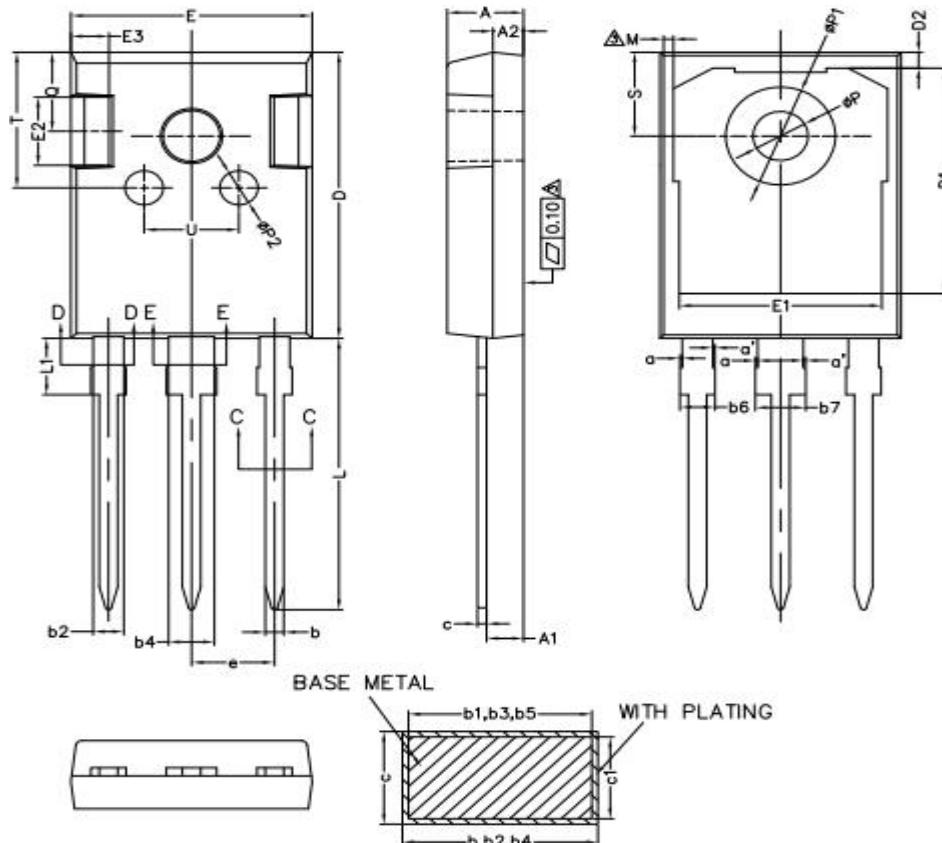
Mechanical Dimensions
TO-247(Package 3)
Unit: mm

Symbol	Dimensions(mm)			Symbol	Dimensions(mm)		
	Min.	Typ.	Max.		Min.	Typ.	Max.
A	4.90	5.00	5.10	c1	0.58	0.60	0.62
A1	2.31	2.41	2.51	D	20.90	21.00	21.10
A2	1.90	2.00	2.10	D1	16.25	16.55	16.85
b	1.16	-	1.26	D2	1.05	1.20	1.35
b1	1.15	1.20	1.22	E	15.70	15.80	15.90
b2	1.96	-	2.06	E1	13.10	13.30	13.50
b3	1.95	2.00	2.02	E2	4.90	5.00	5.10
b4	2.96	-	3.06	E3	2.40	2.50	2.60
b5	2.95	3.00	3.02	e	5.34	5.44	5.54
b6	-	-	2.25	L	19.80	19.92	20.10
b7	-	-	3.25	L1	3.95	4.13	4.30
c	0.59	-	0.66	M	0.35	-	0.95
P	3.50	3.60	3.70	P1	7.00	-	7.40
P2	2.40	2.50	2.60	Q	5.60	-	6.00
S	6.05	6.15	6.25	T	9.80	-	10.20
U	6.00	-	6.40	a	0	-	0.15
a'	0	-	0.15				

Mechanical Dimensions
TO-247(Package 4)

Unit: mm

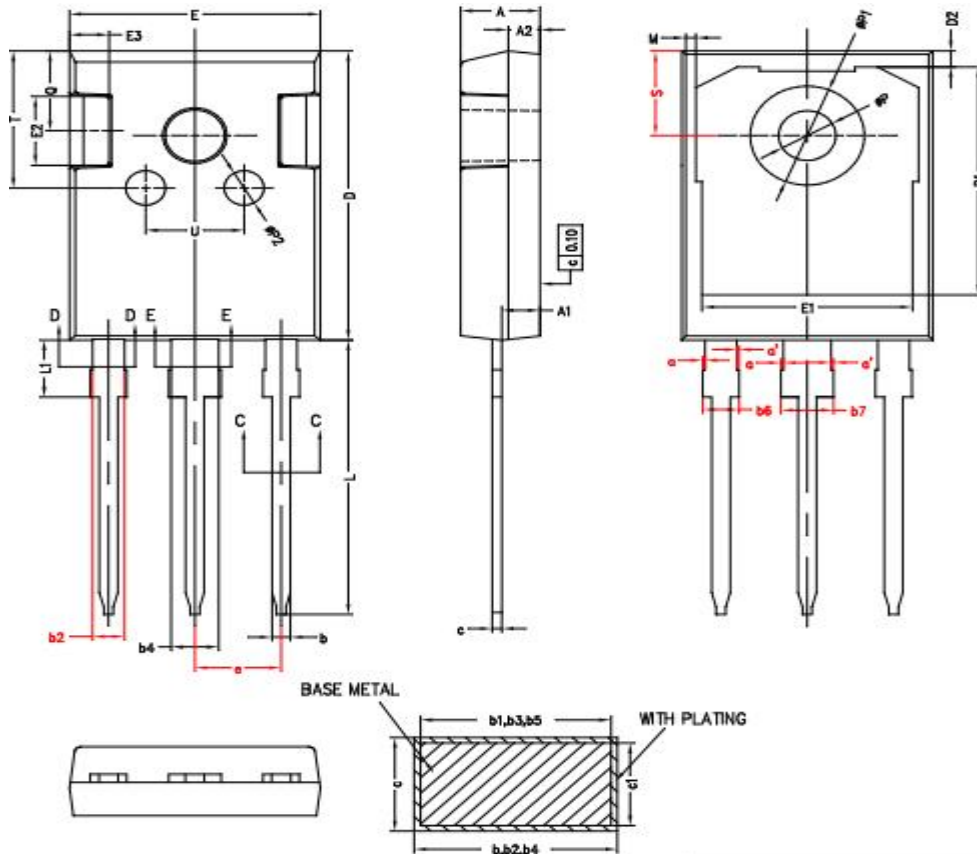

Symbol	Dimensions(mm)			Symbol	Dimensions(mm)		
	Min.	Typ.	Max.		Min.	Typ.	Max.
A	4.90	5.00	5.10	E2	4.90	5.00	5.10
A1	2.31	2.41	2.51	E3	2.40	2.50	2.60
A2	1.90	2.00	2.10	e	5.34	5.44	5.54
b	1.12	-	1.22	L	19.80	19.92	20.10
b1	1.11	1.16	1.18	L1	3.95	4.13	4.30
b2	1.96	-	2.06	P	3.50	3.60	3.70
c	0.59	-	0.66	P1	7.00	-	7.40
D	20.90	21.00	21.10	P2	2.40	2.50	2.60
D1	16.25	16.55	16.85	Q	5.60	-	6.00
D2	1.05	1.20	1.35	S	6.05	6.15	6.25
E	15.70	15.80	15.90	T	9.80	-	10.20
E1	13.10	13.30	13.50	U	6.00	-	6.40
b3	1.95	2.00	2.02	b6	-	-	2.25
b4	2.96	-	3.06	b7	-	-	3.25
b5	2.95	3.00	3.02	c1	0.58	0.60	0.62
M	0.35	-	0.95	a	0	-	0.15
a'	0	-	0.15				

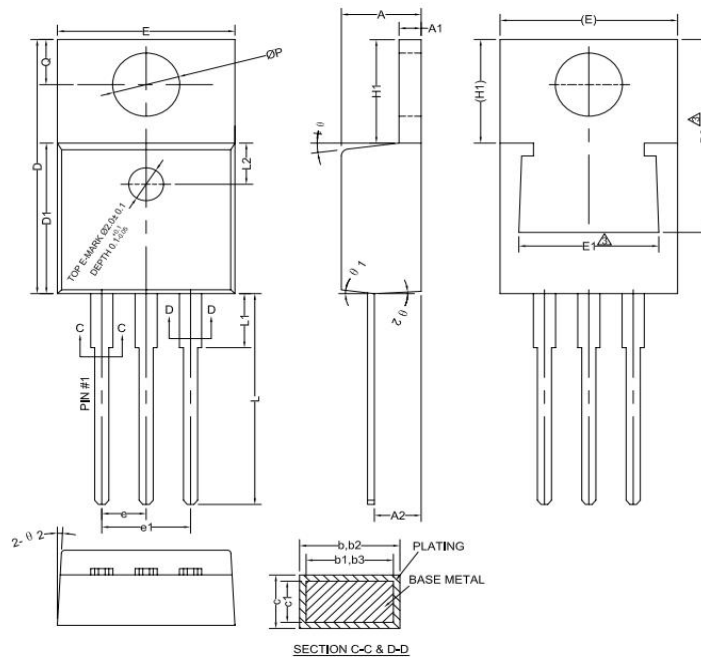
Mechanical Dimensions
TO-220C (Package 1)
Unit: mm

Symbol	Dimensions(mm)		
	Min.	Typ.	Max.
A	4.40	4.57	4.70
A1	1.22	-	1.32
A2	2.59	2.69	2.79
b	0.77	-	0.90
b1	0.76	0.81	0.86
b2	1.23	-	1.36
b3	1.22	1.27	1.32
c	0.34	-	0.47
c1	0.33	0.38	0.43
D	15.15	15.45	15.75
D1	9.05	9.15	9.25
D2	11.40	-	12.88
E	9.96	10.16	10.36
E1	6.86	-	8.89
e	2.44	2.54	2.64
e1	4.98	5.08	5.18
H1	6.10	6.30	6.50
L	12.70	-	13.12
L1	-	-	3.90
ØP	3.80	3.84	3.88
Q	2.60	-	2.90
θ1	5°	7°	9°
θ2	1°	2°	5°

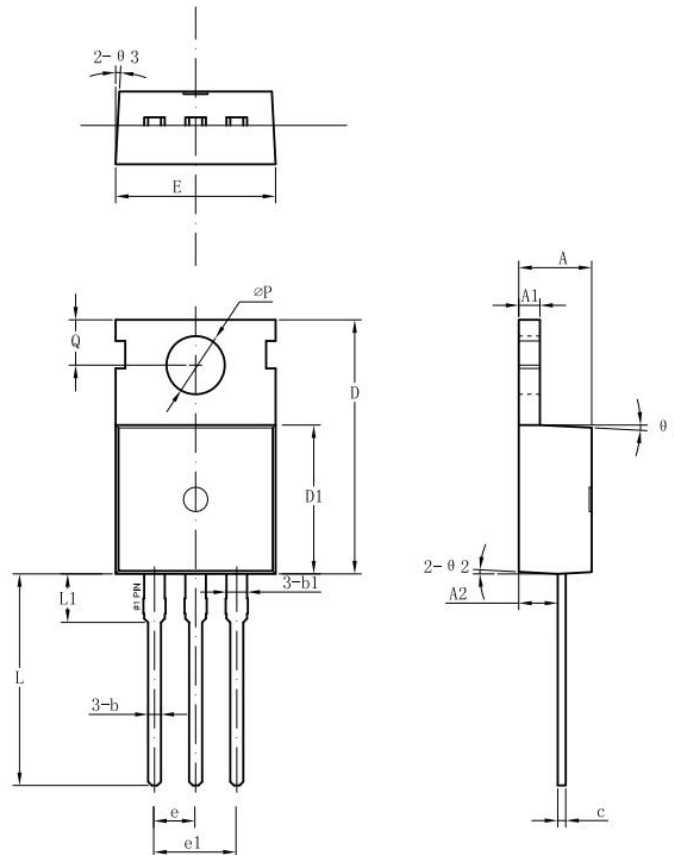
Mechanical Dimensions
TO-220C (Package 2)
Unit: mm

Symbol	Dimensions(mm)		
	Min.	Typ.	Max.
A	4.30	4.50	4.70
A1	1.25	1.30	1.40
A2	2.20	2.40	2.60
b	0.70	0.80	0.95
b1	-	1.27	-
c	0.40	0.50	0.65
D	15.20	15.70	16.20
D1	9.00	9.20	9.40
E	9.70	10.00	10.20
e		2.54	
e1		5.08	
L	12.60	13.08	13.60
L1	-	3.00	-
ϕP	3.50	3.60	3.80
Q	2.60	2.80	3.00
$\theta 1$		3°	
$\theta 2$		3°	
$\theta 2$		3°	

Mechanical Dimensions
TO-220C (Package 3)

Unit: mm

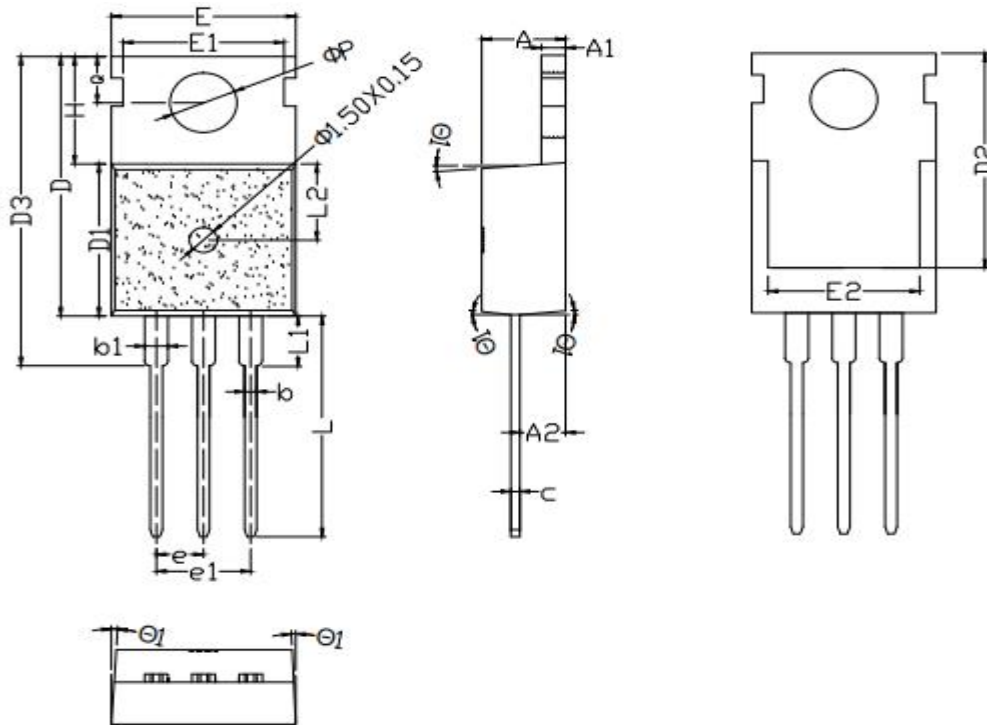

Symbol	Dimensions(mm)		
	Min.	Typ.	Max.
A	4.40	4.50	4.60
A1	1.25	1.30	1.35
A2	2.30	2.40	2.50
b	0.70	0.80	0.90
b1	1.25	1.33	1.42
c	0.45	0.50	0.55
D	15.50	15.75	16.00
D1	9.10	9.20	9.30
D2	12.90	13.10	13.30
D3	15.45	15.80	16.15
E	9.80	10.02	10.15
e	2.54BSC		
e1	5.08BSC		
L	13.00	13.28	13.45
L1	-	-	3.40
ΦP	3.55	3.65	3.75
Q	2.65	2.75	2.85
θ1	2°	-	7°
E1	8.55	8.70	8.85
E2	7.40	7.60	7.80
H	6.40	6.50	6.60
L2	4.50	4.65	4.80



Shenzhen Sanrise Technology Co., LTD.
<http://www.sanrise-tech.com>

IMPORTANT NOTICE

Shenzhen Sanrise Technology Co., LTD. reserves the right to make changes without further notice to any products or specifications herein. Shenzhen Sanrise Technology Co., LTD. does not assume any responsibility for use of any its products for any particular purpose, nor does Shenzhen Sanrise Technology Co., LTD. assume any liability arising out of the application or use of any its products or circuits. Shenzhen Sanrise Technology Co., LTD. does not convey any license under its patent rights or other rights nor the rights of others.

Main Site:

- Headquarter

Shenzhen Sanrise Technology Co., LTD.
A1206, Skyworth building, No. 008, gaoxinnan 1st Road,
Gaoxin District, Yuehai street,, Nanshan District, ShenZhen,
P.R.China
Tel: +86-755-22953335
Fax: +86-755-22916878

- Shanghai Office

Shenzhen Sanrise Technology Co., LTD.
Rm.401, Building B, No. 666, Zhangheng Road,
Zhangjiang Hi-Tech Park, Shanghai, P.R.China
Tel: +86-21-68825918