

NOTES

1. DETAILED DIMENSIONS, SEE PRODUCT DRAWING.
2. NUMBER OF CONNECTORS : 8000PCS/REEL
3. LEAD TAPE LENGTH

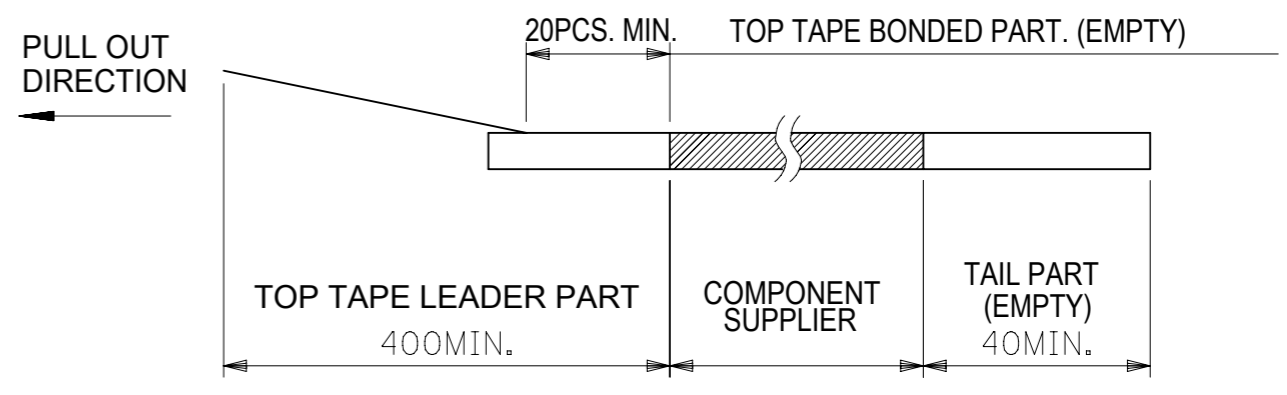

4. TOP TAPE PEEL FORCE IS DEFINED BY IEC60286-3.
5. MATERIAL  
 CARRIER TAPE : POLYSTYRENE  
 TOP TAPE : PET , OTHER  
 REEL : POLYSTYRENE (PS) <RECYCLE MATERIAL CONTAINED>

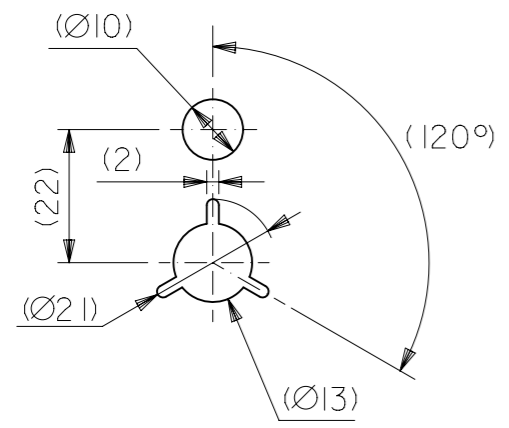

DETAIL "D"

MODEL NO. 504618-\*\*12

THIS DRAWING CONTAINS INFORMATION THAT IS PROPRIETARY TO MOLEX ELECTRONIC TECHNOLOGIES, LLC AND SHOULD NOT BE USED WITHOUT WRITTEN PERMISSION											
EC NO: 115186 DRWN: TNISHIDA02 CHK'D: KTANAKA03 APPR: TKUSUHARA01	GENERAL TOLERANCES (UNLESS SPECIFIED)			DIMENSION UNITS: MM SCALE: 1:5							
	ANGULAR TOL ± °			DRWN BY: TNISHIDA02 DATE: 2017/03/29						0.35 BB CONN. H=0.6 SSB6 REC. ASSY EMBSTP PKG	
	4 PLACES ±			CHK'D BY: KTANAKA03 DATE: 2017/03/31		PRODUCT CUSTOMER DRAWING					
	3 PLACES ±			APPR BY: TKUSUHARA01 DATE: 2017/04/03						SERIES: 504618	
	2 PLACES ±			DRAFT WHERE APPLICABLE MUST REMAIN WITHIN DIMENSIONS		DRAWING SIZE: A3 THIRD ANGLE PROJECTION		DOCUMENT NUMBER: 5046180000		DOC TYPE: PSD	DOC PART: 004

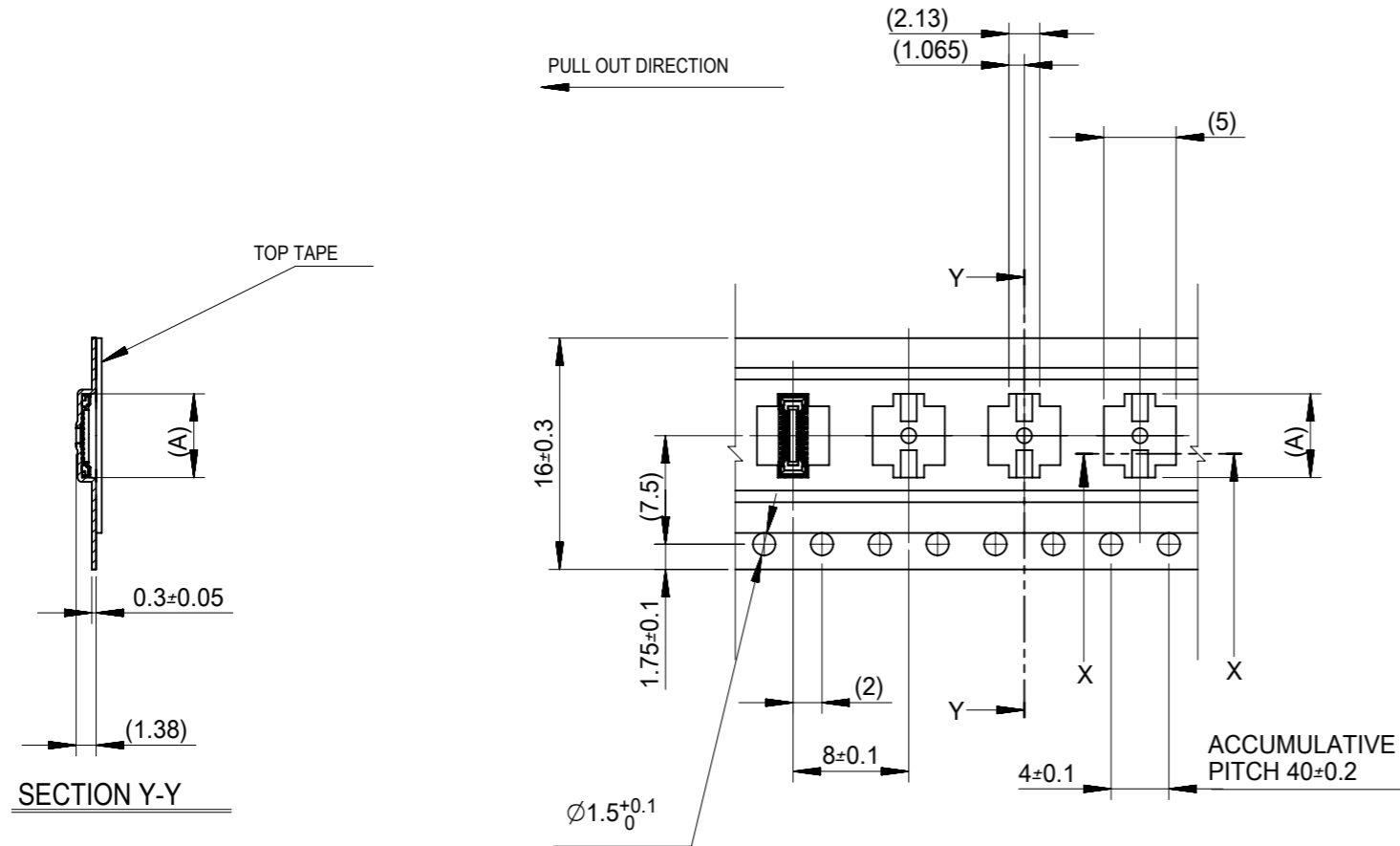

16	21.4	17.4	7.54	504618-3012	○	---	30	
			6.49	504618-2412	○	---	24	
			5.79	504618-2012	○	---	20	
			5.44	---	---	---	18	
			5.09	---	---	---	16	
			4.39	---	---	---	12	
			4.04	504618-1012	○	---	10	
			3.34	---	---	---	6	
キャリアテープ幅 CARRIER TAPE WIDTH		C	B	(A)	EMBOSSED TAPE PACKAGE	HIGH VOL. TOOL	LOW VOL. TOOL	CIRCUIT
					ORDER NO.	SAMPLE PREPARATION ○ : TOOLED △ : WORK IN PROCESS --- : TOOLING TO BE CONFIRMED		

CONNECTOR SERIES NO.:504618-\*\*09

THIS DRAWING CONTAINS INFORMATION THAT IS PROPRIETARY TO MOLEX ELECTRONIC TECHNOLOGIES, LLC AND SHOULD NOT BE USED WITHOUT WRITTEN PERMISSION

EC NO: 115186 DRWN: TNISHIDA02 CHK'D: KTANAKA03 APPR: TKUSUHARA01	2017/03/29 2017/03/31 2017/04/03	GENERAL TOLERANCES (UNLESS SPECIFIED) ANGULAR TOL ± ° 4 PLACES ± 3 PLACES ± 2 PLACES ± 1 PLACE ± 0 PLACES ±	DIMENSION UNITS: MM SCALE: 2:1			
	DRWN BY: TNISHIDA02 DATE: 2017/03/29	CHK'D BY: KTANAKA03 DATE: 2017/03/31	APPR BY: TKUSUHARA01 DATE: 2017/04/03		0.35 BB CONN. H=0.6 SSB6 REC. ASSY EMBSTP PKG	
	DRAFT WHERE APPLICABLE MUST REMAIN WITHIN DIMENSIONS				DRAWING SIZE: A3 THIRD ANGLE PROJECTION	PRODUCT CUSTOMER DRAWING
	SERIES: 504618		MATERIAL NUMBER: SEE CHART		CUSTOMER: GENERAL	
	DOCUMENT NUMBER: 5046180000		DOC TYPE: PSD		DOC PART: 004	SHEET NUMBER: 2 OF 3

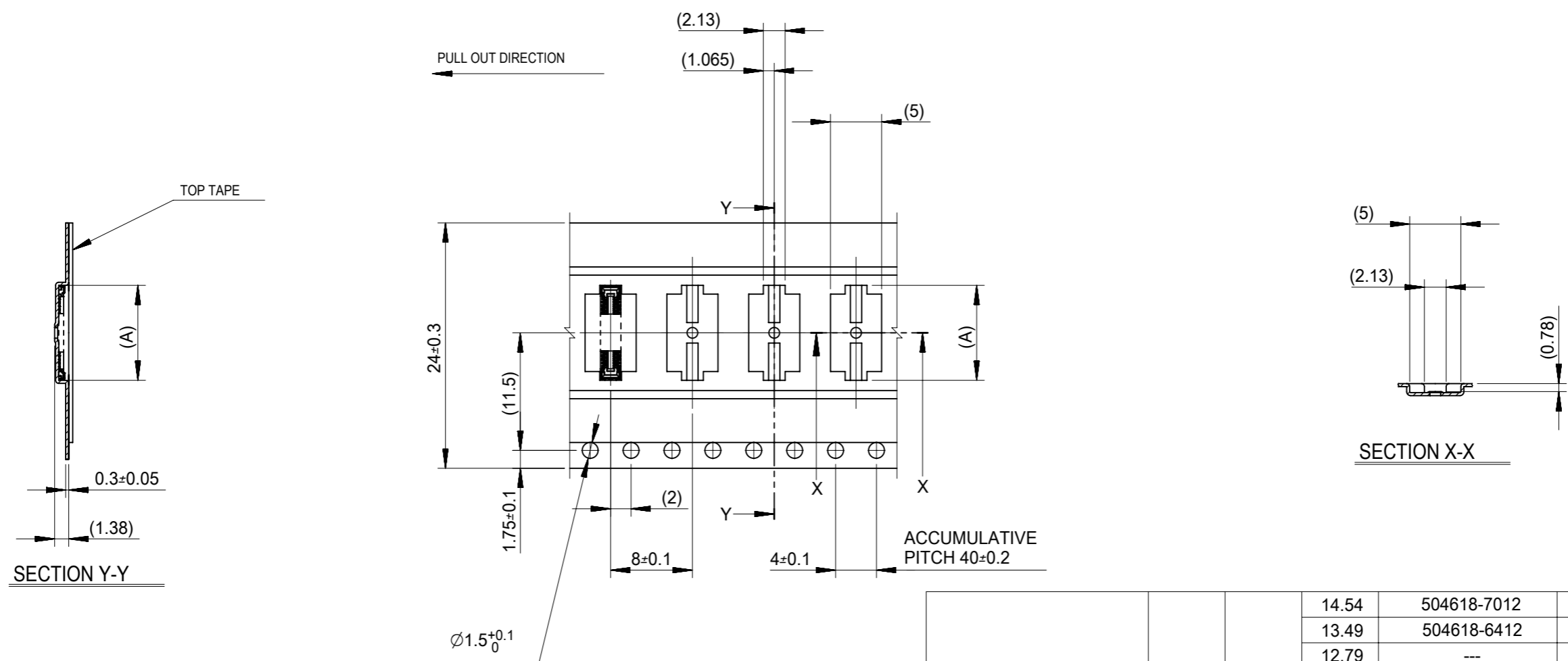

24	29.4	25.4	14.54	504618-7012	○	---	70		
			13.49	504618-6412	○	---	64		
			12.79	---	---	---	60		
			12.44	---	---	---	58		
			11.74	---	---	---	54		
			11.04	504618-5012	○	---	50		
			10.69	---	---	---	48		
			9.46	---	---	---	42		
			9.29	504618-4012	○	---	40		
			8.94	---	---	---	38		
8.24	504618-3412	○	---	34					
キャリアテープ幅 CARRIER TAPE WIDTH			C	B	(A)	EMBOSSED TAPE PACKAGE	HIGH VOL. TOOL	LOW VOL. TOOL	CIRCUIT
						ORDER NO.	SAMPLE PREPARATION ○ : TOOLED △ : WORK IN PROCESS --- : TOOLING TO BE CONFIRMED		

CONNECTOR SERIES NO.:504618-\*\*09

THIS DRAWING CONTAINS INFORMATION THAT IS PROPRIETARY TO MOLEX ELECTRONIC TECHNOLOGIES, LLC AND SHOULD NOT BE USED WITHOUT WRITTEN PERMISSION

EC NO: 115186 DRWN: TNISHIDA02 CHK'D: KTANAKA03 APPR: TKUSUHARA01	2017/03/29 2017/03/31 2017/04/03	GENERAL TOLERANCES (UNLESS SPECIFIED) ANGULAR TOL ± ° 4 PLACES ± 3 PLACES ± 2 PLACES ± 1 PLACE ± 0 PLACES ± DRAFT WHERE APPLICABLE MUST REMAIN WITHIN DIMENSIONS	DIMENSION UNITS	SCALE		
			MM	2:1		
	DRWN BY		DATE	TNISHIDA02		2017/03/29
	CHK'D BY		DATE	KTANAKA03		2017/03/31
	APPR BY		DATE	TKUSUHARA01		2017/04/03
	DRAWING SIZE		THIRD ANGLE PROJECTION	A3		
PRODUCT CUSTOMER DRAWING SERIES: 504618 MATERIAL NUMBER: SEE CHART CUSTOMER: GENERAL						
DOCUMENT NUMBER: 5046180000			DOC TYPE: PSD	DOC PART: 004	SHEET NUMBER: 3 OF 3	

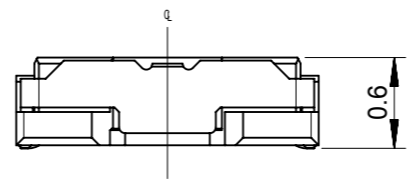
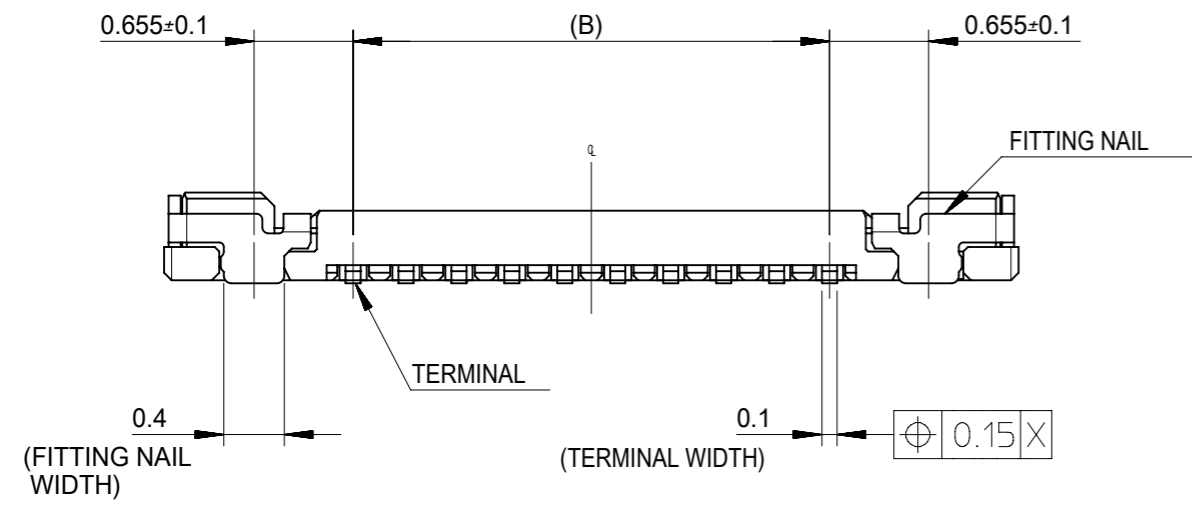
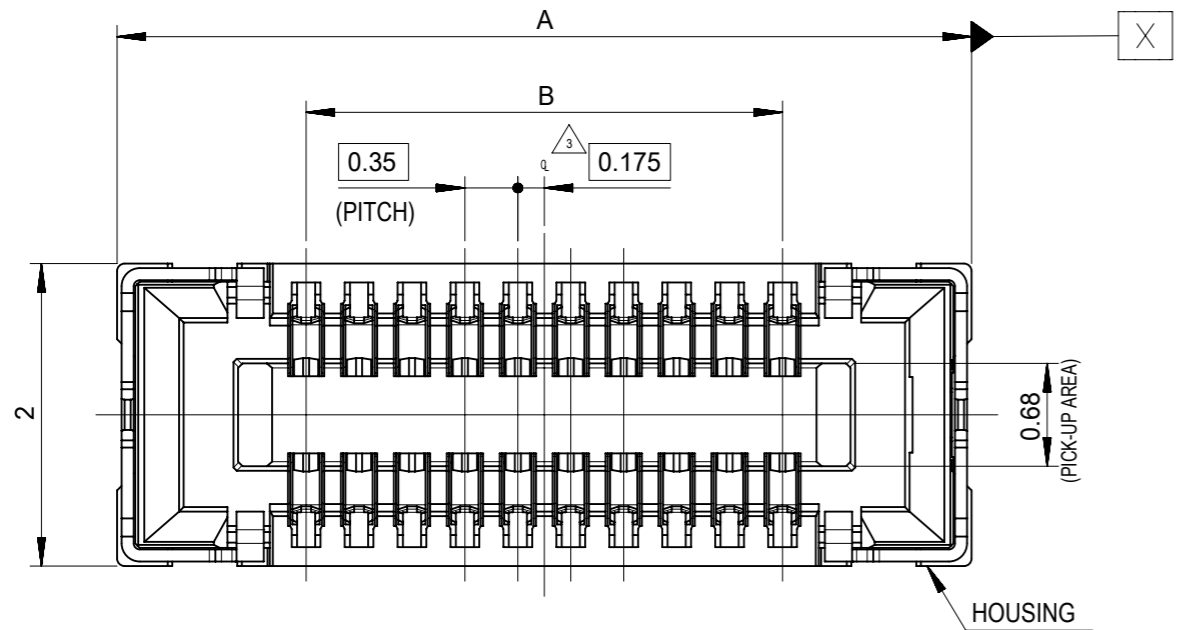

- NOTES
- MATERIAL  
HOUSING : LIQUID CRYSTAL POLYMER UL94V-0(COLOR : BLACK)  
TERMINAL : COPPER ALLOY  
FITTING NAIL : COPPER ALLOY
  - PLATING  
TERMINAL  
GOLD  
UNDER PLATING : NICKEL  
\*DIVIDE INTO PARTS THE GOLD PLATING OF THE CONTACT AND THE TAIL PART BY THE NICKEL PLATING.  
FITTING NAIL  
GOLD  
UNDER PLATING : NICKEL
  - APPLY FOR (CIRCUIT/2)=EVEN.
  - MATE WITH : 504622-\*\*12
  - TAIL AND FITTING NAIL COPLANARITY TO BE 0.08MAXIMUM.
  - PROHIBITED AREA OF PATTERN WIRING AND SOLDER.  
(FOR EACH AREA, THE WIRING THAT TOUCHES ON THE SOLDER CAN BE ATTACHED, THEN COVERED WITH A FILM TO KEEP SOLDER OUT.)
  - ELECTRIC SPEC OF FITTING NAIL IS NOT GUARANTEED WHEN MATED.

11.90±0.25	14.40±0.25	504618-7012	○	---	70
10.85±0.25	13.35±0.25	504618-6412	○	---	64
10.15±0.25	12.65±0.25	---	---	---	60
9.8	12.30±0.25	---	---	---	58
9.10	11.60±0.25	---	---	---	54
8.40	10.90±0.25	504618-5012	○	---	50
8.05	10.55±0.25	---	---	---	48
7.00	9.50	---	---	---	42
6.65	9.15	504618-4012	○	---	40
6.30	8.80	---	---	---	38
5.60	8.10	504618-3412	○	---	34
4.90	7.40	504618-3012	○	---	30
3.85	6.35	504618-2412	○	---	24
3.15	5.65	504618-2012	○	---	20
2.80	5.30	---	---	---	18
2.45	4.95	---	---	---	16
1.75	4.25	---	---	---	12
1.40	3.90	504618-1012	○	---	10
0.70	3.20	---	---	---	6
B	A	EMBOSSED TAPE PACKAGE	HIGH VOL. TOOL	LOW VOL. TOOL	CIRCUIT
		ORDER NO.	SAMPLE PREPARATION ○ : TOOLED △ : WORK IN PROCESS --- : TOOLING TO BE CONFIRMED		

CONNECTOR SERIES No. : 504618-\*\*09

THIS DRAWING CONTAINS INFORMATION THAT IS PROPRIETARY TO MOLEX ELECTRONIC TECHNOLOGIES, LLC AND SHOULD NOT BE USED WITHOUT WRITTEN PERMISSION

EC NO: 115186 DRWN: TNISHIDA02 CHK'D: KTANAKA03 APPR: TKUSUHARA01	2017/03/29 2017/03/31 2017/04/03	GENERAL TOLERANCES (UNLESS SPECIFIED) ANGULAR TOL ± 1.0 °	DIMENSION UNITS: MM SCALE: 20:1		
	4 PLACES ± 0.2 3 PLACES ± 0.2 2 PLACES ± 0.2 1 PLACE ± 0.2 0 PLACES ± 0.2	DRWN BY: TNISHIDA02 DATE: 2017/03/29	DRIFT WHERE APPLICABLE MUST REMAIN WITHIN DIMENSIONS		THIRD ANGLE PROJECTION
	PRODUCT CUSTOMER DRAWING	CHK'D BY: KTANAKA03 DATE: 2017/03/31	DRAWING SIZE: A3		SERIES: 504618 MATERIAL NUMBER: SEE CHART CUSTOMER: GENERAL
	DRAFT WHERE APPLICABLE MUST REMAIN WITHIN DIMENSIONS	APPR BY: TKUSUHARA01 DATE: 2017/04/03	DOCUMENT NUMBER: 5046181000 DOC TYPE: PSD DOC PART: 003 SHEET NUMBER: 1 OF 2		

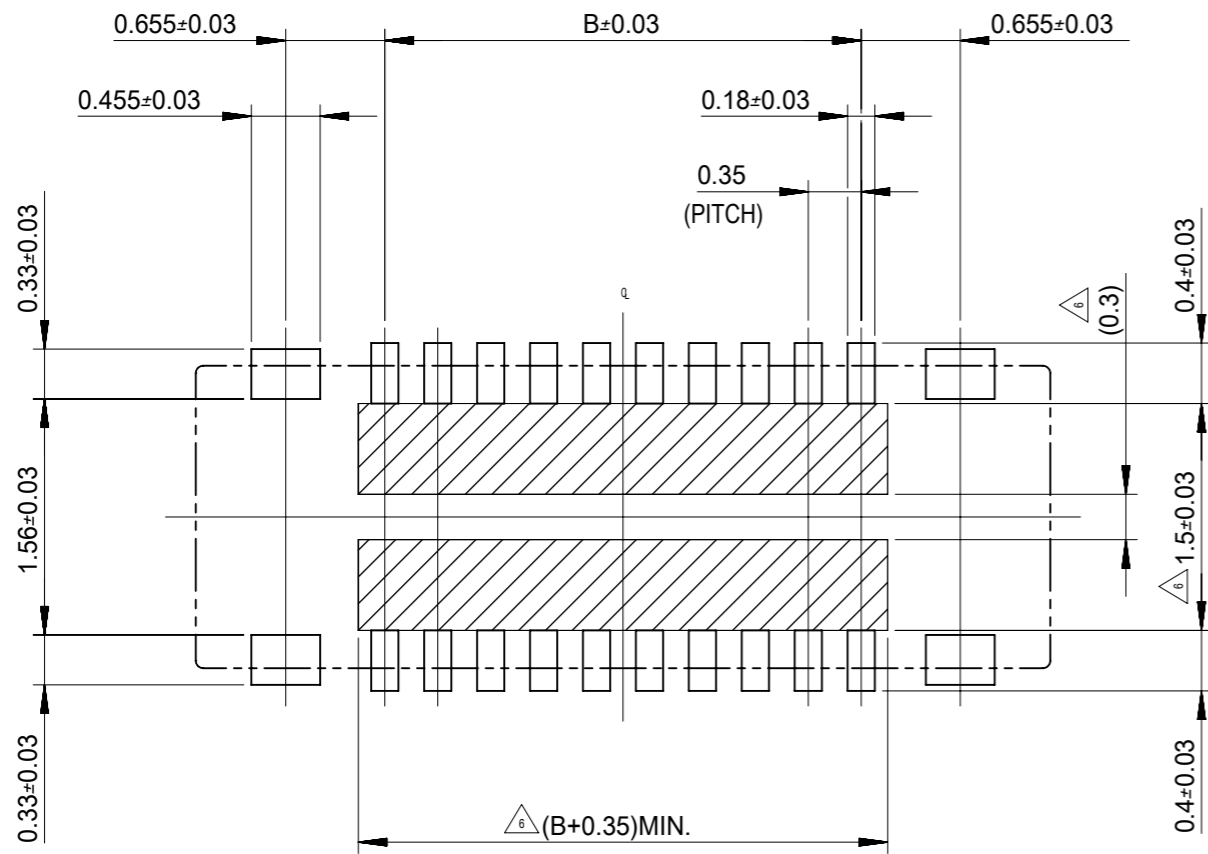

RECOMMENDED P.W.BOARD PATTERN LAYOUT(REFERENCE)

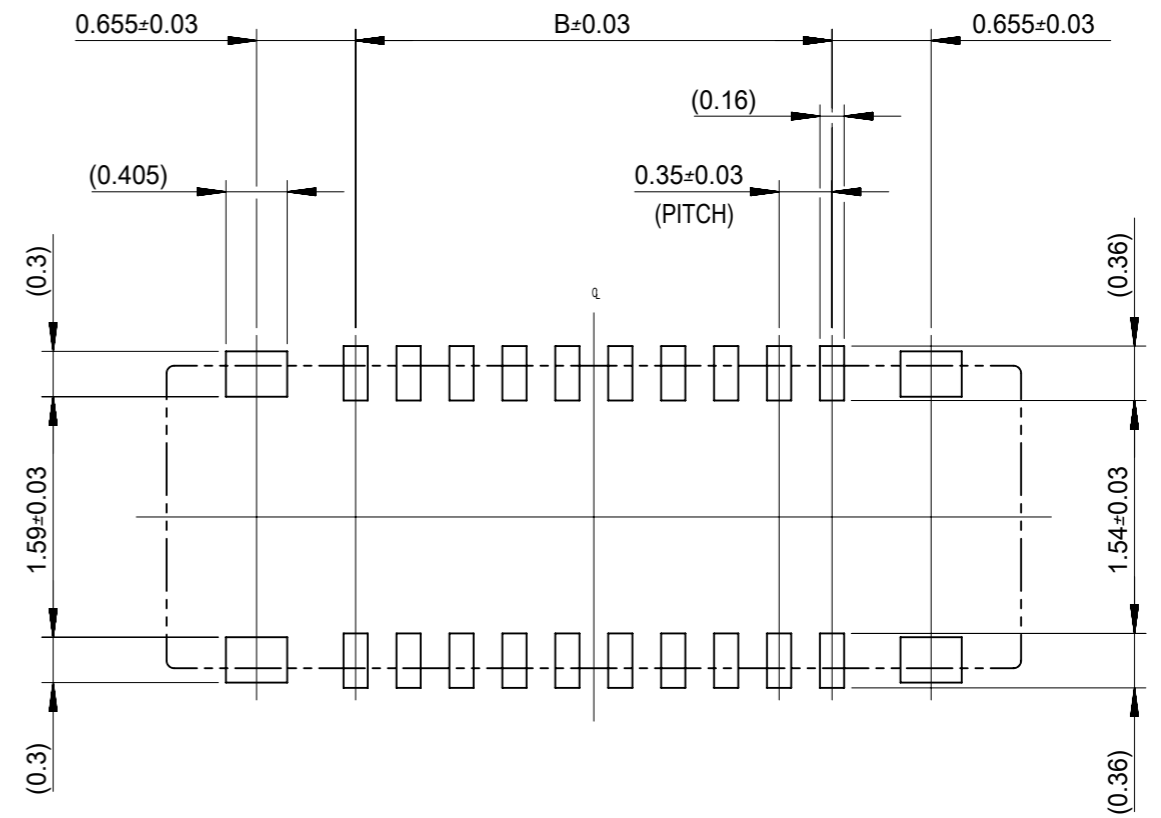

RECOMMENDED METAL MASK LAYOUT(REFERENCE)

RECOMMENDED THICKNESS OF METAL MASK :  $t=0.08\text{mm}$   
 RECOMMENDED OPEN APERTURE RATIO OF METAL MASK : 80%

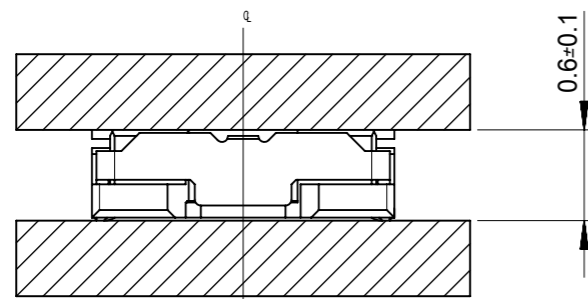

MATED CONDITION

THIS DRAWING CONTAINS INFORMATION THAT IS PROPRIETARY TO MOLEX ELECTRONIC TECHNOLOGIES, LLC AND SHOULD NOT BE USED WITHOUT WRITTEN PERMISSION

EC NO: 115186 DRWN: TNISHIDA02 CHK'D: KTANAKA03 APPR: TKUSUHARA01	2017/03/29 2017/03/31	GENERAL TOLERANCES (UNLESS SPECIFIED) ANGULAR TOL $\pm 1.0^\circ$ 4 PLACES $\pm 0.2$ 3 PLACES $\pm 0.2$ 2 PLACES $\pm 0.2$ 1 PLACE $\pm 0.2$ 0 PLACES $\pm 0.2$ DRAFT WHERE APPLICABLE MUST REMAIN WITHIN DIMENSIONS	DIMENSION UNITS <b>MM</b>	SCALE <b>20:1</b>			
	DRWN BY <b>TNISHIDA02</b>		DATE <b>2017/03/29</b>	DRWN BY <b>TNISHIDA02</b>		DATE <b>2017/03/29</b>	<b>0.35 BB CONN. H=0.6</b> <b>SSB6 REC. ASSY</b>
	CHK'D BY <b>KTANAKA03</b>		DATE <b>2017/03/31</b>	CHK'D BY <b>KTANAKA03</b>		DATE <b>2017/03/31</b>	
	APPR BY <b>TKUSUHARA01</b>		DATE <b>2017/04/03</b>	APPR BY <b>TKUSUHARA01</b>	DATE <b>2017/04/03</b>		
	RELEASED		A	DRAFTING SIZE <b>A3</b>	THIRD ANGLE PROJECTION	DRAWING SIZE <b>A3</b>	PRODUCT CUSTOMER DRAWING
SERIES <b>504618</b>	MATERIAL NUMBER <b>SEE CHART</b>	CUSTOMER <b>GENERAL</b>	DOCUMENT NUMBER <b>5046181000</b>	DOC TYPE <b>PSD</b>	DOC PART <b>003</b>	SHEET NUMBER <b>2 OF 2</b>	