

2 MHz, 1 A Synchronous Step-Down Converter

General Description

The XTP8011 is a high-efficiency monolithic synchronous buck regulator using a constant frequency, current mode architecture. The device is available in an adjustable version. Supply current with no load is 70 μ A and drops to <1 μ A in shutdown. The 2.5V to 5.5V input voltage range makes the XTP8011 ideally suited for single Li-Ion battery powered applications. 100% duty cycle provides low dropout operation, extending battery life in portable systems. PWM/PFM mode operation provides very low output ripple voltage for noise sensitive applications.

Switching frequency is internally set at 2MHz, allowing the use of small surface mount inductors and capacitors. Low output voltages are easily supported with the 0.6V feedback reference voltage.

Application

- Cellular and Smart Phones
- Wireless and DSL Modems
- Portable Instruments
- Digital Still and Video Cameras
- PC Card

Features

- High Efficiency: Up to 96%
- 2.5V to 5.5V Input Voltage Range
- 2MHz Constant Frequency Operation
- Low Dropout Operation: 100% Duty Cycle
- PFM Mode for High Efficiency in Light Load
- Over temperature Protected
- Low Quiescent Current: 70 μ A
- Short Circuit Protection
- Over Voltage Protection
- Inrush Current Limit and Soft Start
- RoHS and Halogen free compliance
- SOT23-5L package

Typical Application Circuit

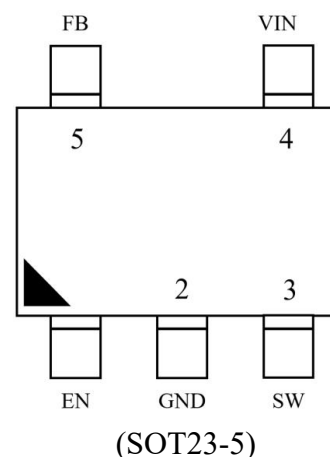

Typical Application Circuit

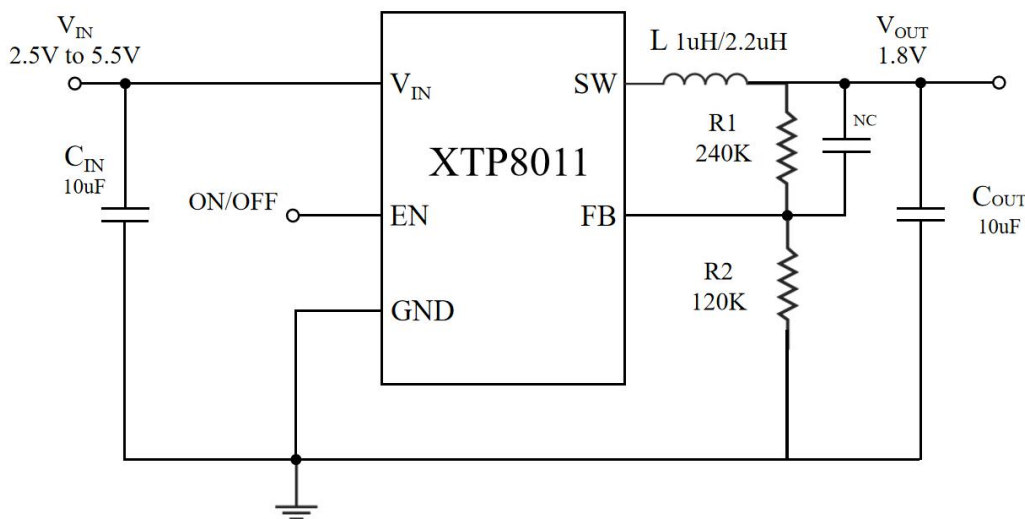

Function Order Information

PIN	Pin Name	Pin Function
1	EN	Chip Enable Pin. Drive EN above 1V to turn on the part. Drive EN below 0.3V to turn it off. Do not leave EN floating.
2	GND	Ground Pin
3	SW	Power Switch Output. It is the switch node connection to Inductor. This pin connects to the drains of the internal P-ch and N-ch MOSFET switches.
4	V _{IN}	Power Supply Input. Must be closely decoupled to GND with a 10μF or greater ceramic capacitor.
5	FB	Output Voltage Feedback Pin. An internal resistive divider divides the output voltage down for comparison to the internal reference voltage.

Order Information

Part Number	Package	Top Marking	PACKING OPTION
XTP8011AS2CT	SOT23-5	P8011 YWZZX	Tape and Reel, 3000

MARKING INFORMATION

NOTE:

P8011: Device Code.

YW : Date Code.

ZZX: Inside Code.

Function Block Diagram

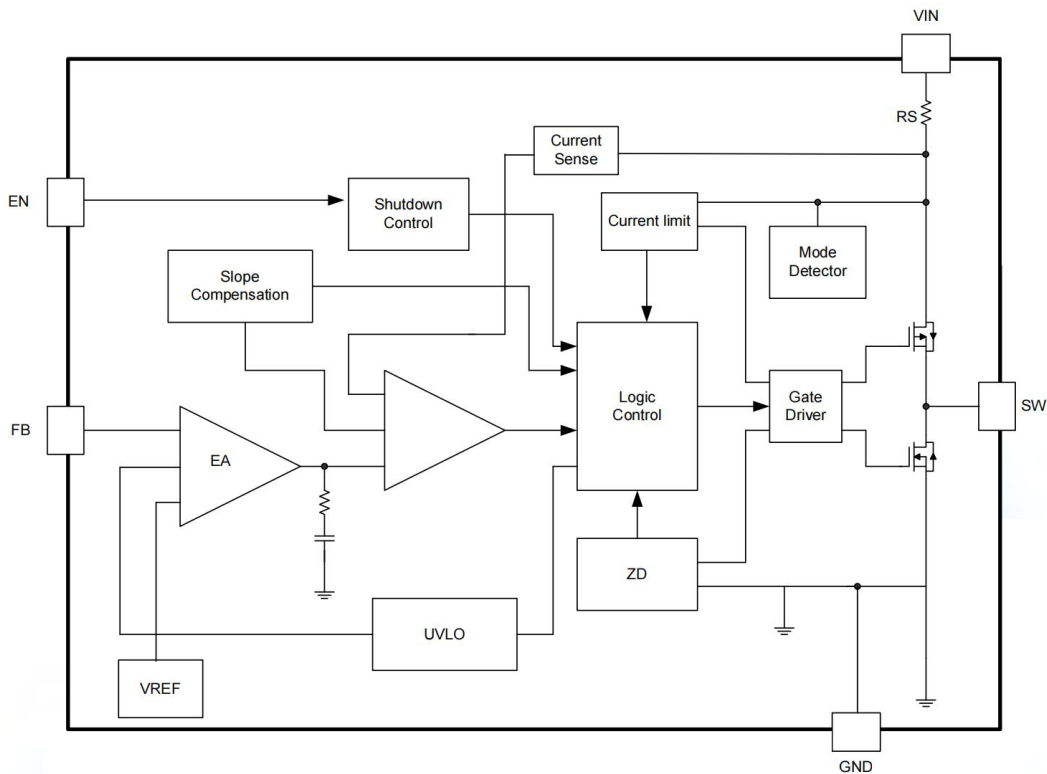

Absolute Maximum Ratings

PARAMETER		Min	Typ	Max	Unit
V_{IN} to GND ⁽¹⁾		-0.3		7.0	V
EN Voltage		-0.3		6	V
SW Voltage		-0.3		$V_{in}+0.3$	V
Peak SW Sink and Source Current			2.2		A
Continuous Power Dissipation ($T_A = 25^\circ\text{C}$) ⁽²⁾	SOT23-5L		0.5		W
Junction Temperature		-40		165	$^\circ\text{C}$
Lead Temperature			260		$^\circ\text{C}$
Storage Temperature		-65		150	$^\circ\text{C}$
Thermal Resistance ⁽³⁾	θ_{JA}		170		$^\circ\text{C/W}$
	θ_{JC}	SOT23-5L	75		

Notes:

- (1) Exceeding these ratings may damage the device.
- (2) The maximum allowable power dissipation is a function of the maximum junction temperature $T_{J(MAX)}$, the junction-to-ambient thermal resistance θ_{JA} , and the ambient temperature T_A . The maximum allowable continuous power dissipation at any ambient temperature is calculated by $PD(MAX)=(T_{J(MAX)}-T_A)/\theta_{JA}$. Exceeding the maximum allowable power dissipation will cause excessive die temperature, and the regulator will go into thermal shutdown. Internal thermal shutdown circuitry protects the device from permanent damage.
- (3) Measured on JESD51-7, 4-layer PCB.

Electrical Characteristics

All typical values are at Tj=25°C (unless otherwise noted)

Parameter	Test Conditions	Min	Typ	Max	Unit
Input Voltage range		2.5	--	5.5	V
V _{OVP}			6.1		V
UVLO		2.1	2.3	2.5	V
UVLO hysteresis		0.1	0.2	0.3	V
FB voltage	No load	588	600	612	mV
Switching frequency	V _{FB} =0.5V	1.6	2	2.4	M
Max duty cycle			100		%
No load supply current a V _{IN}			70	120	uA
Shutdown Supply Current at V _{IN}	EN=0		0.1	1	uA
Efficiency	I _{LOAD} =0.6A	85	90		%
Line regulation	I _{LOAD} =300mA		0.1	0.2	%/V
Load regulation	I _{LOAD} =0-1.0A		0.1	0.2	%/V
NMOS Switch On Resistance	I _{SW} =100mA		250	250	mΩ
PMOS Switch On Resistance	I _{SW} =100mA		350	350	mΩ
Peak Current Limit		1.4	1.8	2.2	A
SW Leakage Current	V _{IN} = 6V, V _{SW} = 0 or 6V, EN=0			10	uA
OTP		135	150	165	°C
OTP hysteresis		20	30	40	°C
EN Input Low Voltage				0.3	V
EN Input High Voltage		1			V

Function Descriptions

The XTP8011 uses a constant frequency, current mode step-down architecture. Both the main (P-channel MOSFET) and synchronous (N-channel MOSFET) switches are internal. During normal operation, the internal top power MOSFET is turned on each cycle when the oscillator sets the RS latch, and turned off when the current comparator, ICOMP, resets the RS latch. The peak inductor current at which ICOMP resets the RS latch, is controlled by the output of error amplifier EA. When the load current increases, it causes a slight decrease in the feedback voltage, FB, relative to the 0.6V reference, which in turn, causes the EA amplifier's output voltage to increase until the average inductor current matches the new load current. While the top MOSFET is off, the bottom MOSFET is turned on until either the inductor current starts to reverse, as indicated by the current reversal comparator IRCMP, or the beginning of the next clock cycle.

Setting the Output Voltage

In the adjustable version, the output voltage is set by a resistive divider according to the following formula:

$$R_2 = \frac{R_1}{\frac{V_{out}}{V_{FB}} - 1}$$

The external resistive divider is connected to the output, allowing remote voltage sensing as shown in on page 1.

Inductor Selection

For most designs, the XTP8011 operates with inductors of 1 μ H to 4.7 μ H. Low inductance values are physically smaller but require faster switching, which results in some efficiency loss. The inductor value can be derived from the following equation:

$$L = \frac{V_{OUT} \times (V_{IN} - V_{OUT})}{V_{IN} \times \Delta I_L \times f_{OSC}}$$

Where ΔI_L is inductor Ripple Current. Large value inductors result in lower ripple current and small value inductors result in high ripple current. For optimum voltage-positioning load transients, choose an inductor with DC series resistance in the 50m Ω to 150m Ω range.

Input Capacitor Selection

Higher values, lower cost ceramic capacitors are now becoming available in smaller case sizes. Their high ripple current, high voltage rating and low ESR make them ideal for switching regulator applications. Because the XTP8011's control loop does not depend on the output capacitor's ESR for stable operation, ceramic capacitors can be used freely to achieve very low output ripple and small circuit size. However, care must be taken when ceramic capacitors are used at the input and the output. When a ceramic capacitor is used at the input and the power is supplied by a wall adapter through long wires, a load step at the output can induce ringing at the input, V_{IN} . At best, this ringing can couple to the output and be mistaken as loop instability. At worst, a sudden inrush of current through the long wires can potentially cause a voltage spike at V_{IN} , large enough to damage the part. When choosing the input and output ceramic capacitors, choose the X5R or X7R dielectric formulations. These dielectrics have the best temperature and voltage characteristics of all the ceramics for a given value and size.

PCB Layout Checklist

When laying out the printed circuit board, the following checking should be used to ensure proper operation of the XTP8011. Check the following in your layout:

1. The power traces, consisting of the GND trace, the SW trace and the V_{IN} trace should be kept short, direct and wide.
2. Place the C_{IN} to XTP8011's V_{IN} and GND pins as closely as possible. This capacitor provides the AC current to the internal power MOSFETs.
3. Better to make a star connection of ground node for C_{IN} , XTP8011's ground and C_{OUT} .
4. Keep the switching node, SW, away from the sensitive feedback node.
5. Keep the (-) terminal of C_{IN} and C_{OUT} as close as possible, to minimize current loop area for EMI concern.

Typical Characteristics

($C_{IN}=C_{OUT}=10\mu F$, $L=2.2\mu H$, $14m\Omega$, $T_A = 25^\circ C$, unless otherwise specified)

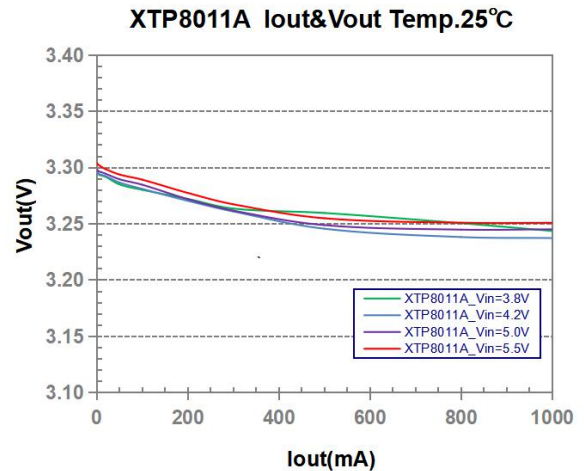
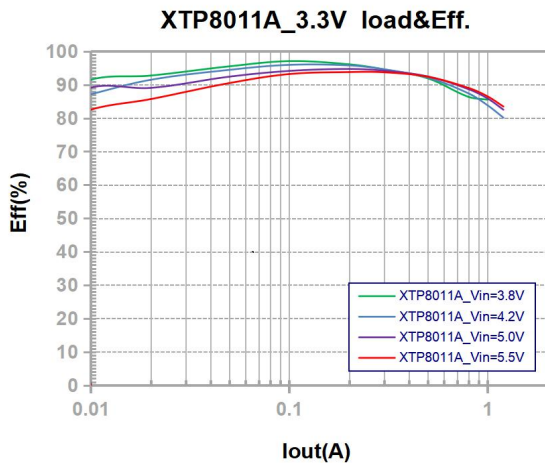
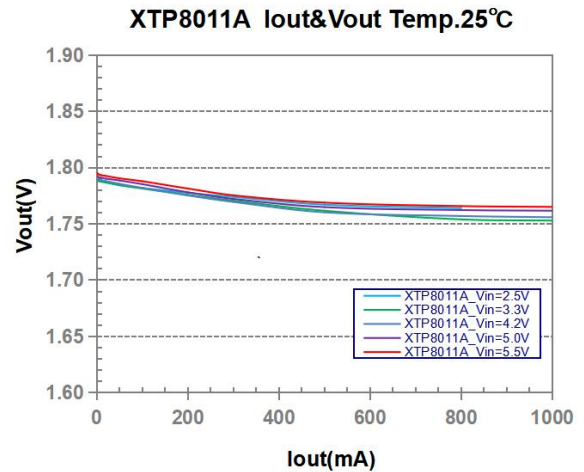
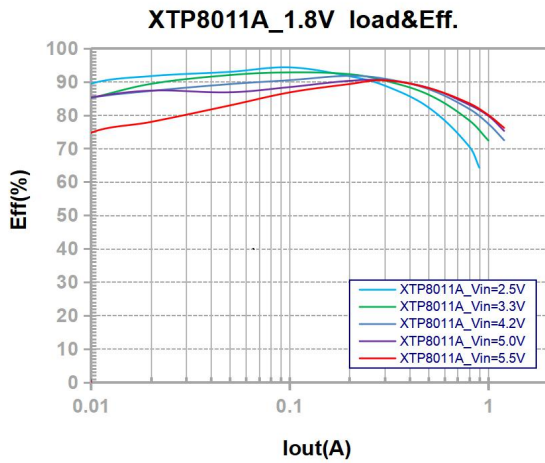
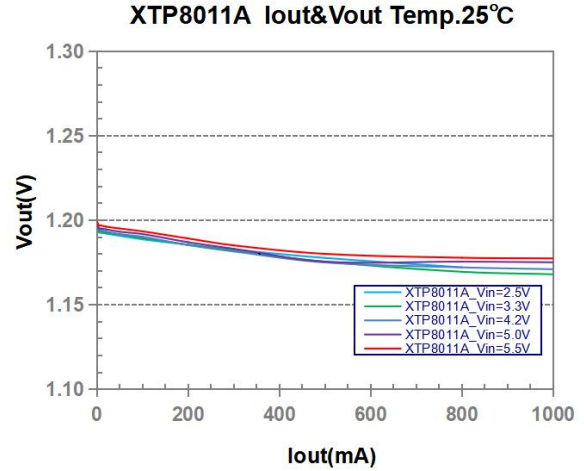
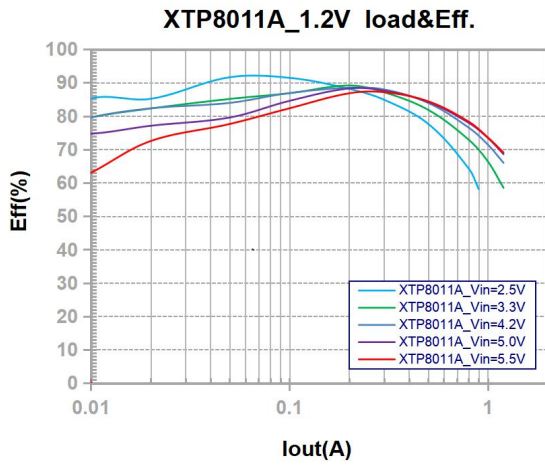

Iq Vs. Vin

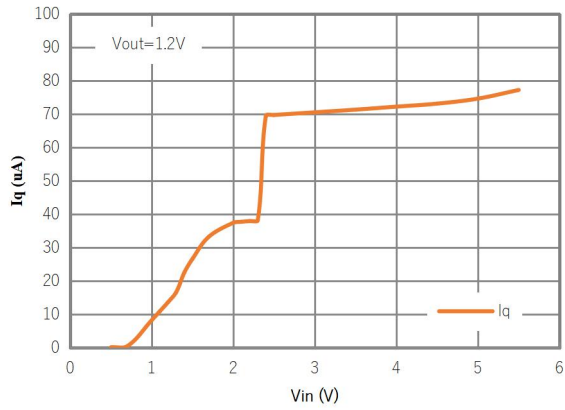

Vout Vs. Temp

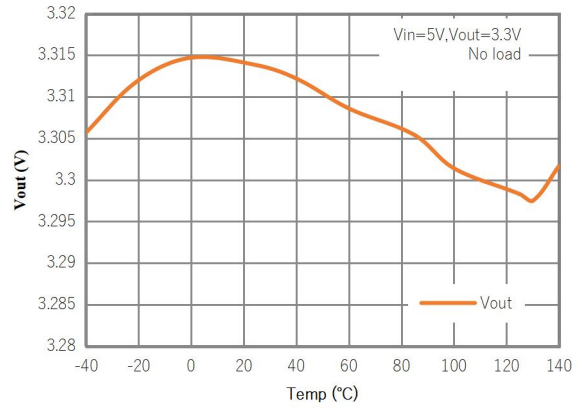

EN ON_OFF, Vin=5V, Vout=3.3V, Iout=0.5A

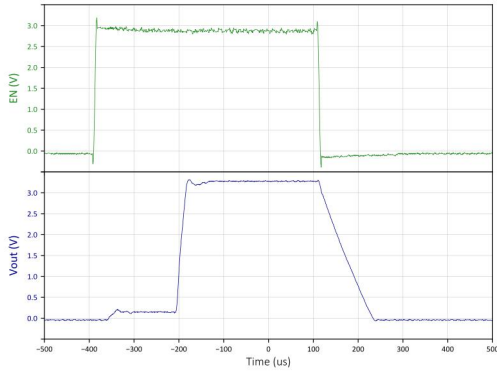

Load Transient Vin=5V, Vout=3.3V, Iout = 0.01 - 0.5A

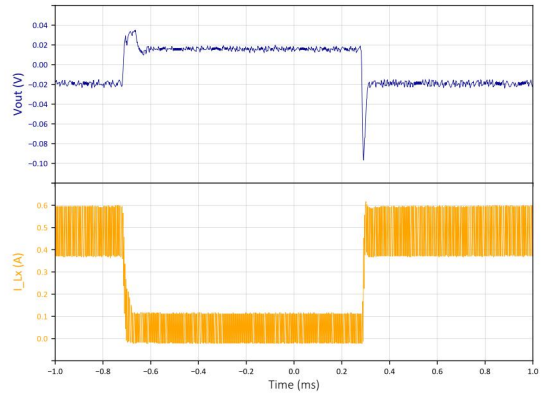

Operation Waveform Vin=5V, Vout=3.3V, Iout=0.5A

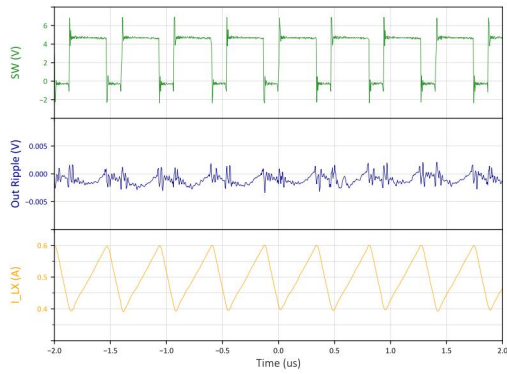

Power ON, Vin=5V, Vout=3.3V, Iout=0.5A

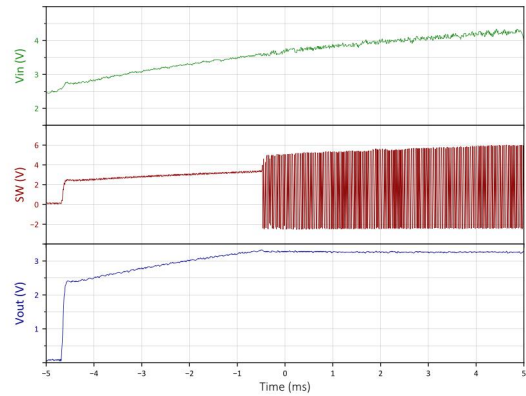

Package Information

Package dimension (mm)

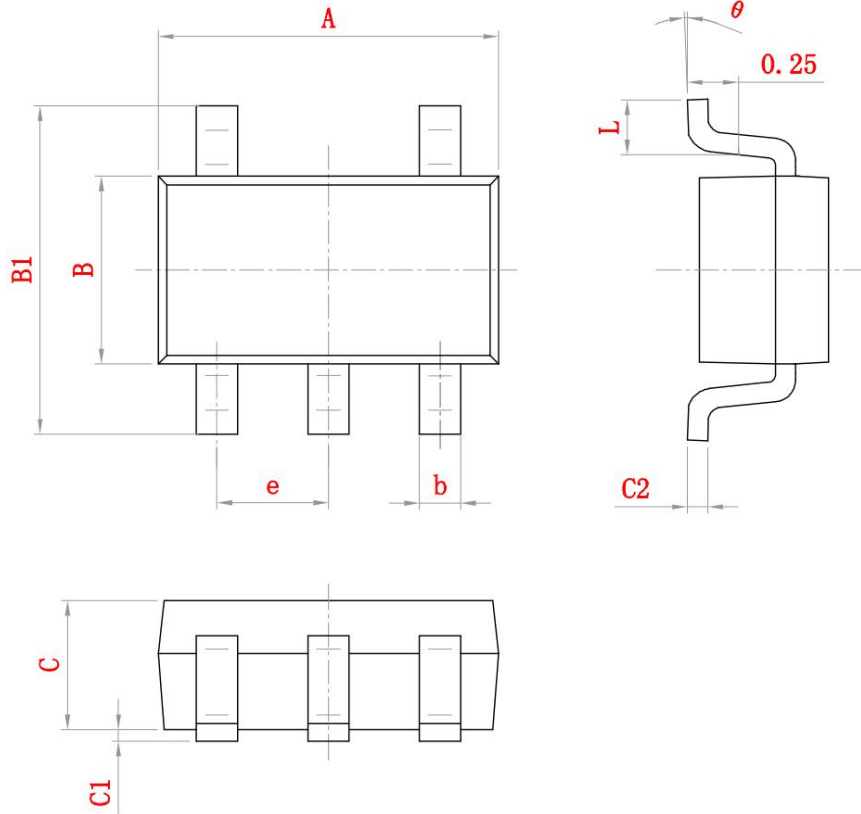

SOT23-5L

Symbol	Min(mm)	Max(mm)	Symbol	Min(mm)	Max(mm)
A	2.82	3.02	C	1.05	1.15
e	0.95(BSC)		C1	0.03	0.15
b	0.28	0.45	C2	0.12	0.23
B	1.50	1.70	L	0.35	0.55
B1	2.60	3.00	θ	0°	8°