

General Description

RC4580IDR is the dual operational amplifier specially designed for improving the tone control which is most suitable for the audio application. Featuring noiseless, higher gain bandwidth, high output current and low distortion ratio, and it is most suitable not only for acoustic electronic part of audio pre-amp and active filter, but also for the industrial measurement tools. It is also suitable for the head phone amp at higher output current. And furthermore, it can be applied for the handy type set operational amplifier of general purpose in application of low voltage single supply type which is properly biased of the input low voltage source.

Features

- Operating Voltage (2V ~ 18V)
- Low Input Noise Voltage (0.8Vrms Typ.)
- Wide Gain Bandwidth Product (15MHz Typ.)
- Low Distortion (0.0005% Typ.)
- Slew Rate (5V/s Typ.)
- Package Outline
- Bipolar Technology

Package Information

Part NO.	Package	Package Marking	Package Option
RC4580IDR	SOP-8		2500

Notes: xxx represents the internal production number of the factory.

Equivalent Circuit Pin Configuration

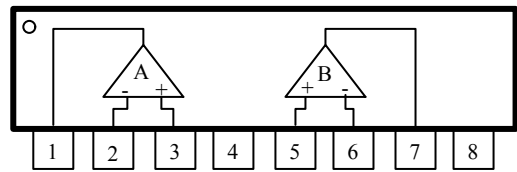
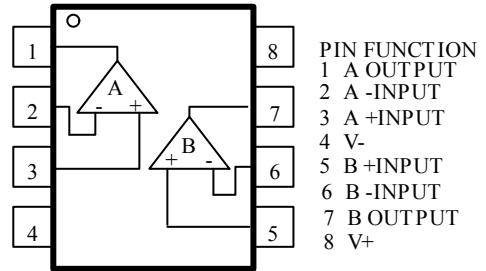
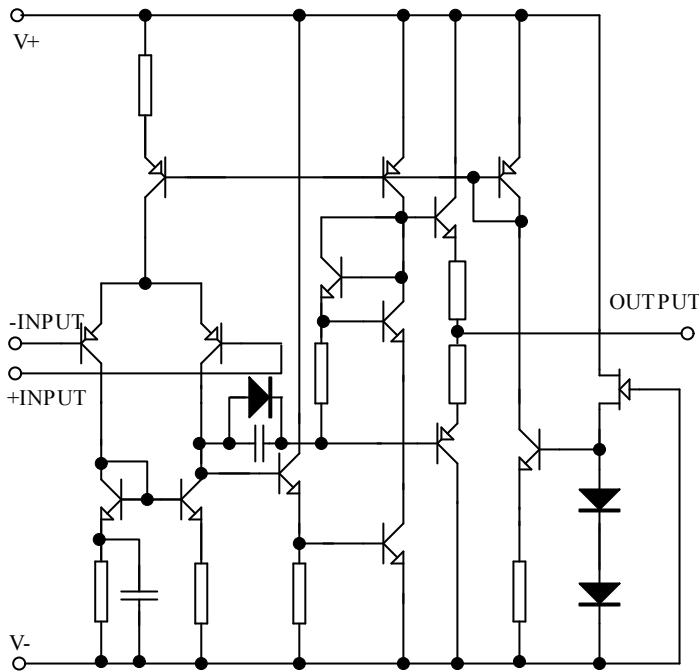

Absolute Maximum Ratings (Ta=25°C)

Characteristic	Symbol	Value	Unit
Supply Voltage	V+/V-	±18	V
Input Voltage	V _{IC}	±18	V
Differential Input Voltage	V _{ID}	±36	V
Output Current	I _c	±50	mA
Operating Temperature Range	T _{amb}	-40~85	°C
Storage Temperature Range	T _{stg}	-65~125	°C

Electrical Characteristics

(Unless otherwise specified: $T_a=25^{\circ}\text{C}$, $V_+/V_-=\pm 15\text{V}$)

Parameter	Symbol	Test condition	Min	Typ	Max	Unit
Input Offset Voltage	V_{IO}	$R_s \leq 10\text{k}\Omega$	-	0.3	3	mV
Input Offset Current	I_{IO}		-	5	200	nA
Input Bias Current	I_B		-	100	500	nA
Input Resistance	R_{in}		-	0.5	-	$\text{M}\Omega$
Large Signal Voltage Gain	A_v	$R_L \geq 2\text{k}\Omega$, $V_o = \pm 10\text{V}$	90	110	-	dB
Output Voltage Swing	V_{OM}	$R_L \geq 2\text{k}\Omega$	± 12	± 13.5	-	V
Input Common Mode Voltage Range	V_{ICM}		± 12	± 13.5	-	V
Common Mode Rejection Ratio	CMR	$R_s \leq 10\text{k}\Omega$	80	110	-	dB
Supply Voltage Rejection Ratio	SVR	$R_s \leq 10\text{k}\Omega$	80	110	-	dB
Operating Current	I_{cc}		-	6	9	mA
Slew Rate	SR	$R_L \geq 2\text{k}\Omega$	-	5	-	$\text{V}/\mu\text{s}$
Gain Bandwidth Product	GB	$f=10\text{kHz}$	-	15	-	MHz
Total Harmonic Distortion	THD	$A_v=20\text{dB}$, $V_o=5\text{V}$, $f=1\text{kHz}$, $R_L=2\text{k}\Omega$	-	0.0005	-	%
Input Noise Voltage1	V_{NI}	RIAA $R_s=2.2\text{k}\Omega$, 30kHz LPF	-	0.8	-	μV_{rms}
Input Noise Voltage2	e_n	$f=1\text{kHz}$	-	5	-	nV/Hz

Characteristic Curves

Maximum Output Voltage Swing vs. Load Resistance

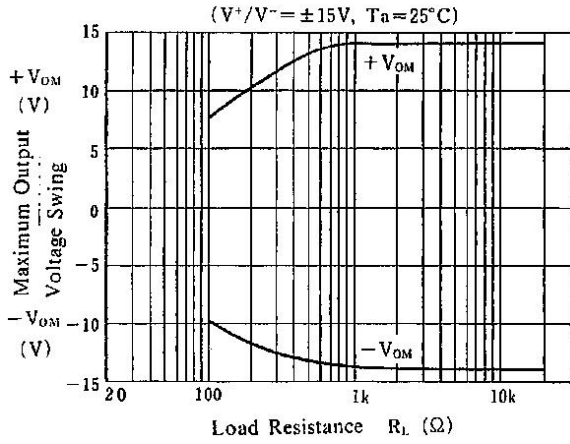

Maximum Output Voltage Swing vs. Frequency

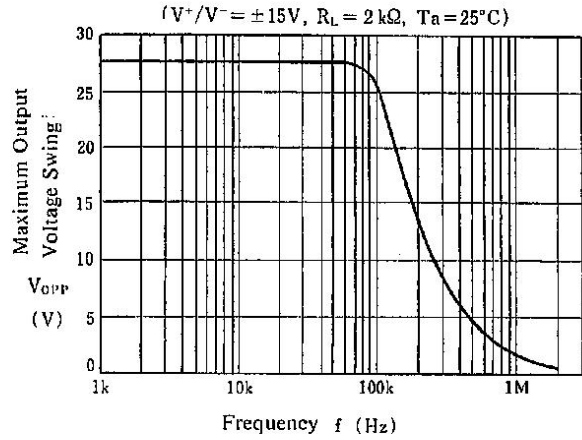

Output Voltage Swing vs. Output Current

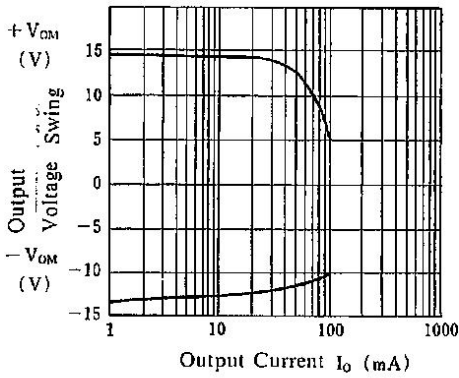

Equivalent Input Noise Voltage vs. Frequency

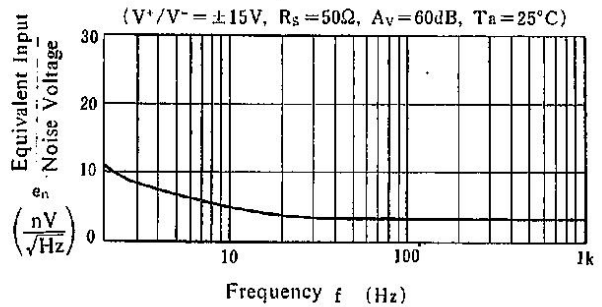

Operating Current vs. Temperature

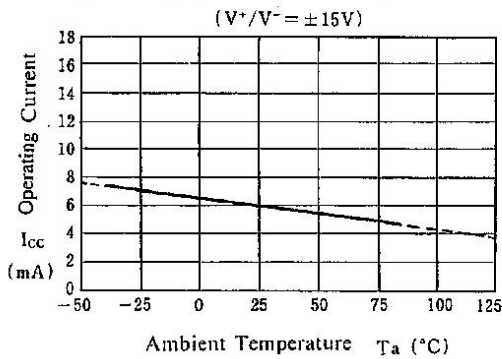

Output Voltage Swing vs. Temperature

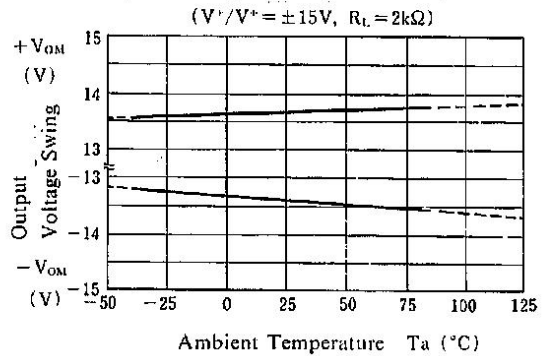

Input Offset Voltage vs. Temperature

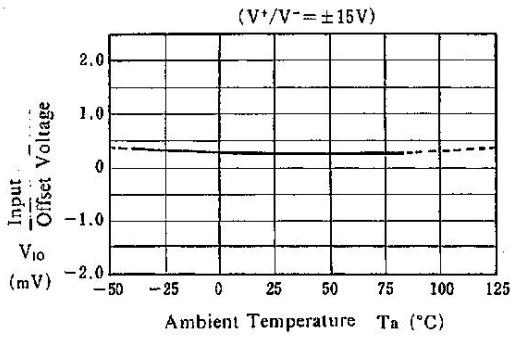

Input Bias Current vs. Temperature

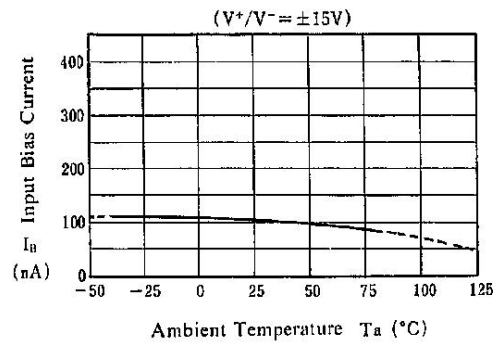

Maximum Output Voltage Swing vs. Operating Voltage

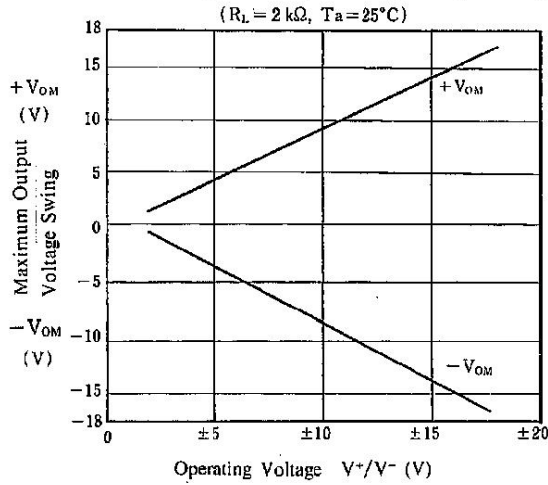

Operating Current vs. Operating Voltage

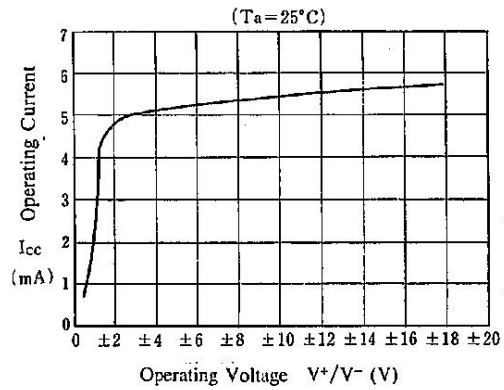

Total Harmonic Distortion vs. Output Voltage

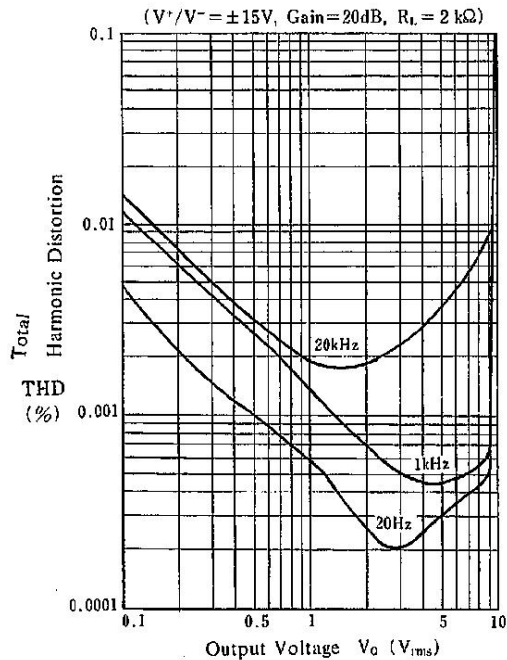

Voltage Gain, Phase vs. Frequency

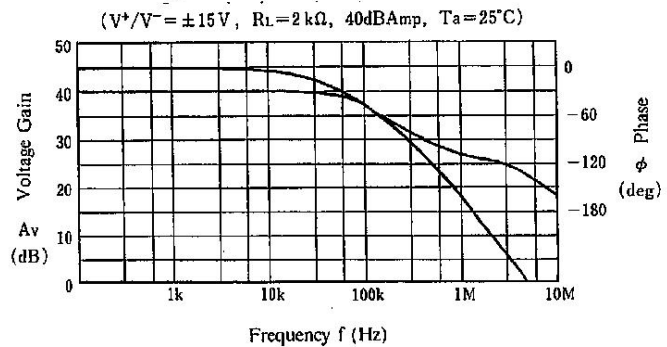

SOP-8

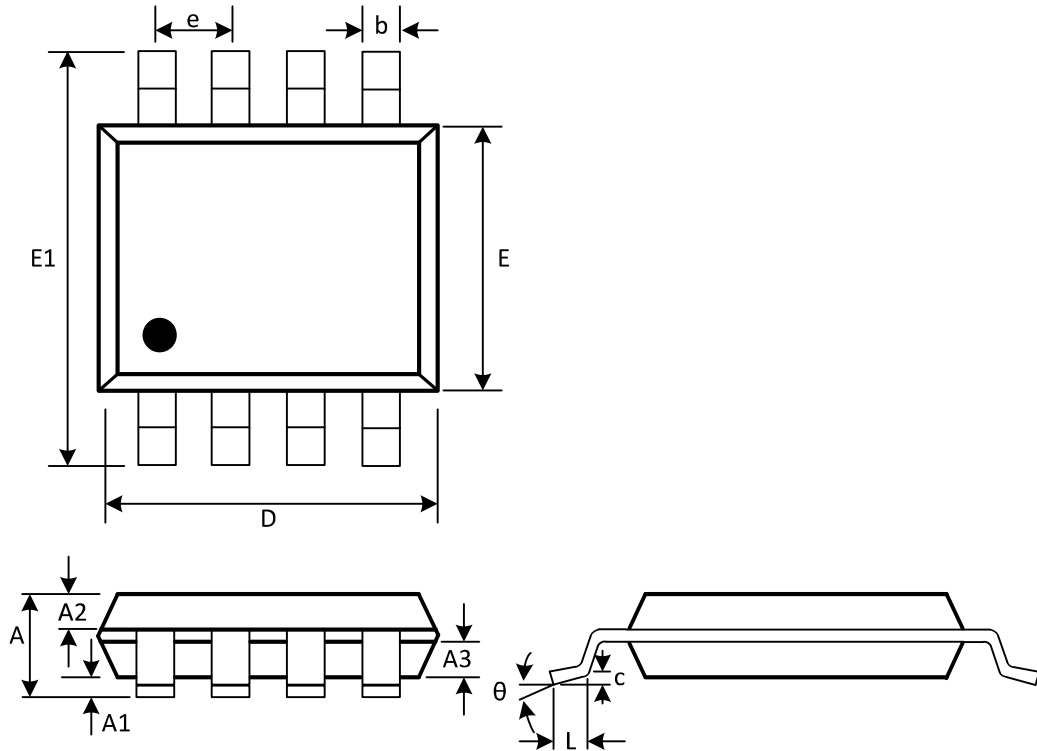

(Unit: mm)

Symbol	Min	Max
A	1.300	1.600
A1	0.050	0.200
A2	0.550	0.650
A3	0.550	0.650
b	0.356	0.456
c	0.203	0.233
D	4.800	5.000
e	1.270(BSC)	
E	3.800	4.000
E1	5.800	6.200
L	0.400	0.800
theta	0°	8°