

LMBTA06LT1G

S-LMBTA06LT1G

Driver Transistors

1. FEATURES

- We declare that the material of product compliance with RoHS requirements and Halogen Free.
- S- prefix for automotive and other applications requiring unique site and control change requirements; AEC-Q101 qualified and PPAP capable.

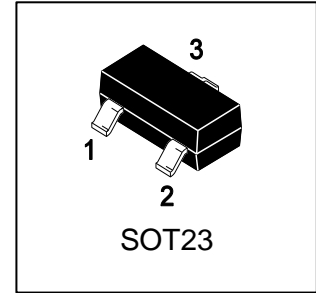

2. DEVICE MARKING AND ORDERING INFORMATION

Device	Marking	Shipping
LMBTA06LT1G	1GM	3000/Tape&Reel
LMBTA06LT3G	1GM	10000/Tape&Reel

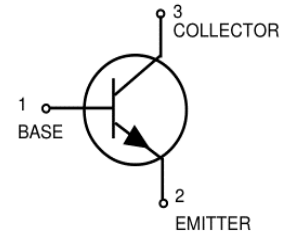

3. MAXIMUM RATINGS(Ta = 25°C)

Parameter	Symbol	Limits	Unit
Collector-Emitter Voltage	VCEO	80	V
Collector-Base voltage	VCBO	80	V
Emitter-Base Voltage	VEBO	4	V
Collector current-continuoun	IC	500	mA

4. THERMAL CHARACTERISTICS

Parameter	Symbol	Value	Unit
Total Device Dissipation FR-5 Board (Note 1) TA = 25°C	PD	225	mW
Derate above 25°C		1.8	mW/°C
Thermal Resistance, Junction to Ambient	RθJA	556	°C/W
Total Device Dissipation Alumina Substrate(Note 2) TA = 25°C	PD	300	mW
Derate above 25°C		2.4	mW/°C
Thermal Resistance, Junction to Ambient	RθJA	417	°C/W
Junction and Storage Temperature	TJ , Tstg	-55~+150	°C

1. FR-5 = 1.0 x 0.75 x 0.062 in.

2. Alumina = 0.4 x 0.3 x 0.024 in. 99.5% alumina.

5. ELECTRICAL CHARACTERISTICS (Ta= 25°C)

Characteristic	Symbol	Min.	Typ.	Max.	Unit
OFF CHARACTERISTICS					
Collector–Emitter Breakdown Voltage(Note 3) (IC =1.0 mA, IB = 0)	V(BR)CEO	80	-	-	V
Emitter–Base Breakdown Voltage (IE = 100 μA, IC = 0)	V(BR)EBO	4	-	-	V
Collector-Base Breakdown voltage (IC = 100μA, IE = 0)	V(BR)CBO	80	-	-	V
Collector Cutoff Current (VCE = 60V, IB = 0)	ICES	-	-	0.1	μA
Collector Cutoff Current (VCB = 80V, IE = 0)	ICBO	-	-	0.1	μA
Emitter Cutoff Current (VEB = 4V, IC = 0)	IEBO	-	-	0.1	μA
ON CHARACTERISTICS					
DC Current Gain (IC = 10 mA, VCE = 1.0 V) (IC = 100 mA, VCE = 1.0 V)	hFE	100 100	- -	- -	
Collector–Emitter Saturation Voltage (IC = 100 mA, IB = 10 mA)	VCE(sat)	-	-	0.25	V
Base–Emitter Saturation Voltage (IC = 100 mA, IB = 10 mA)	VBE(sat)	-	-	1.2	V
SMALL–SIGNAL CHARACTERISTICS					
Current –Gain – Bandwidth Product(Note 4) (VCE = 2.0 V, IC = 10mA, f = 100 MHz)	fT	100	-	-	MHz

3. Pulse Test: Pulse Width ≤300 μs, Duty Cycle ≤2.0%.

4. fT is defined as the frequency at which |hfe| extrapolates to unity.

6.ELECTRICAL CHARACTERISTICS CURVES

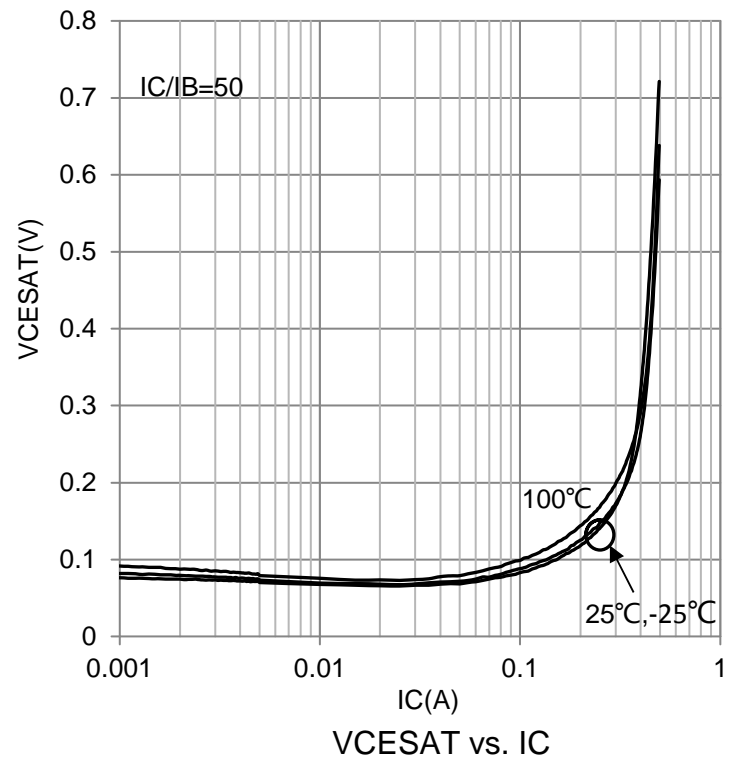
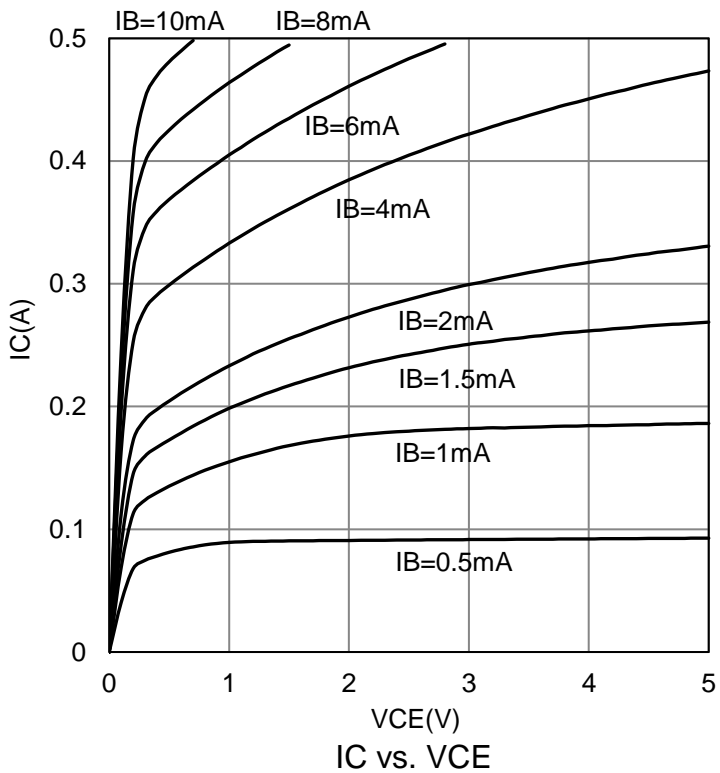
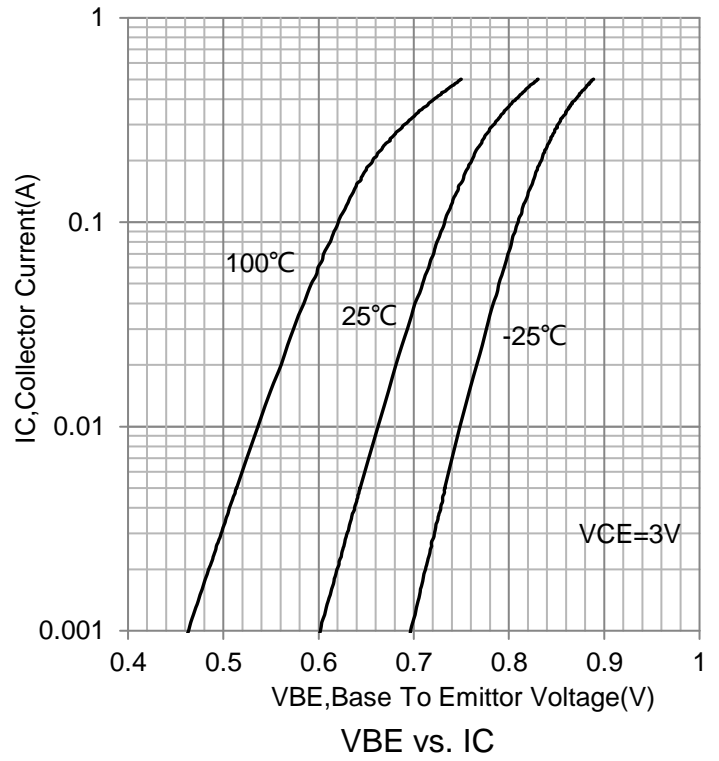
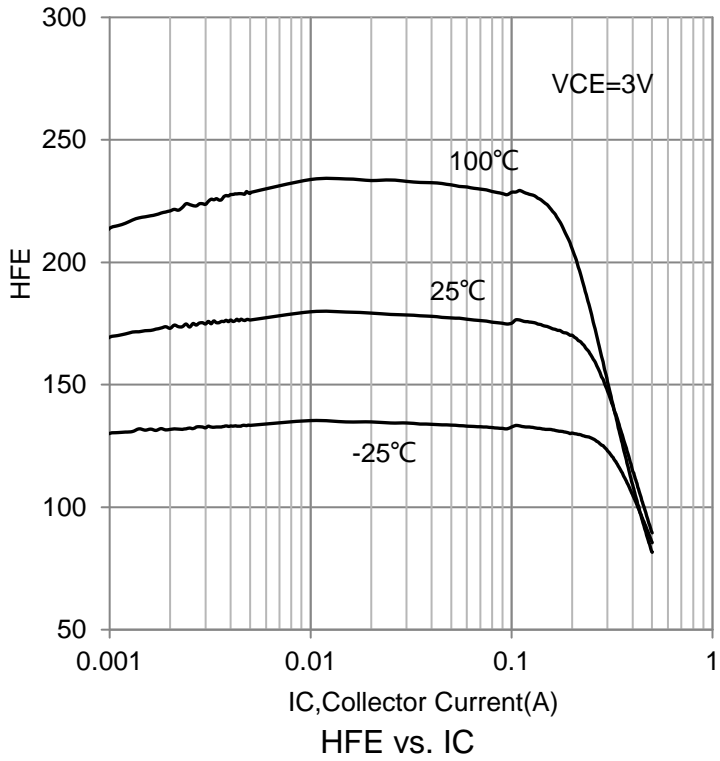

6.ELECTRICAL CHARACTERISTICS CURVES(Con.)

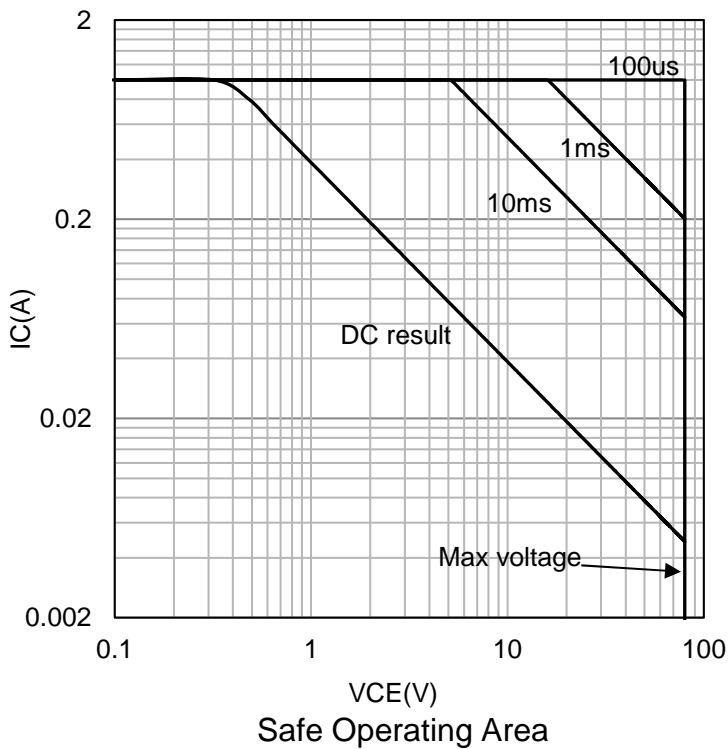
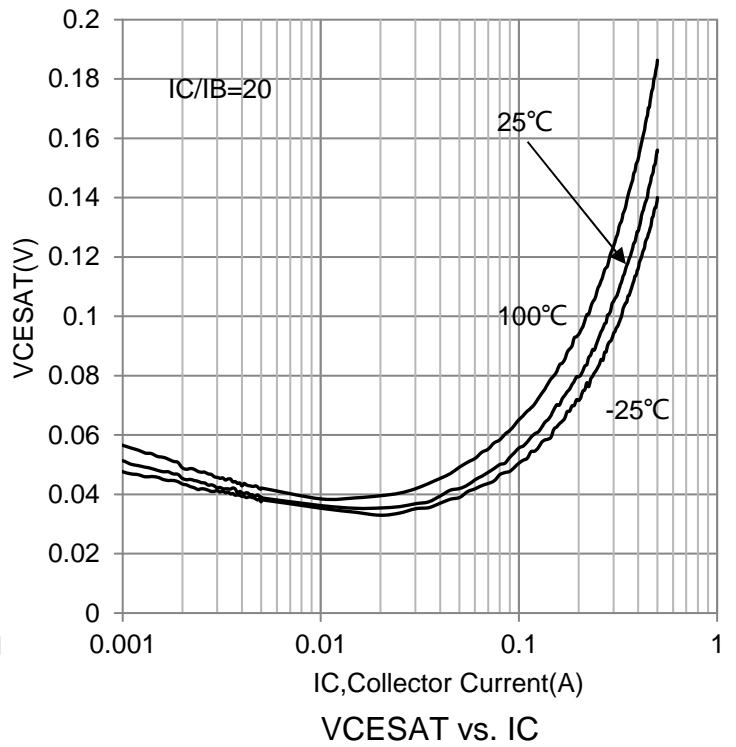
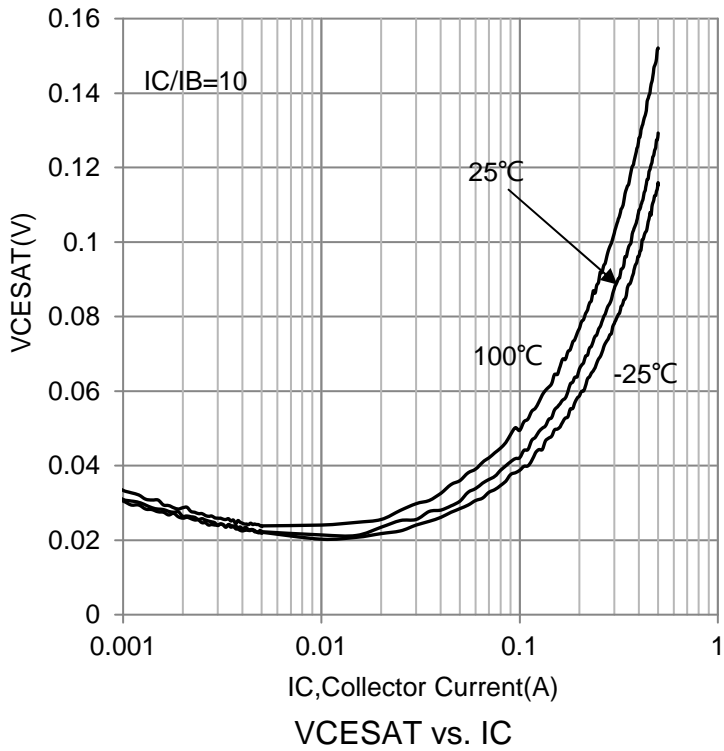

7.OUTLINE AND DIMENSIONS

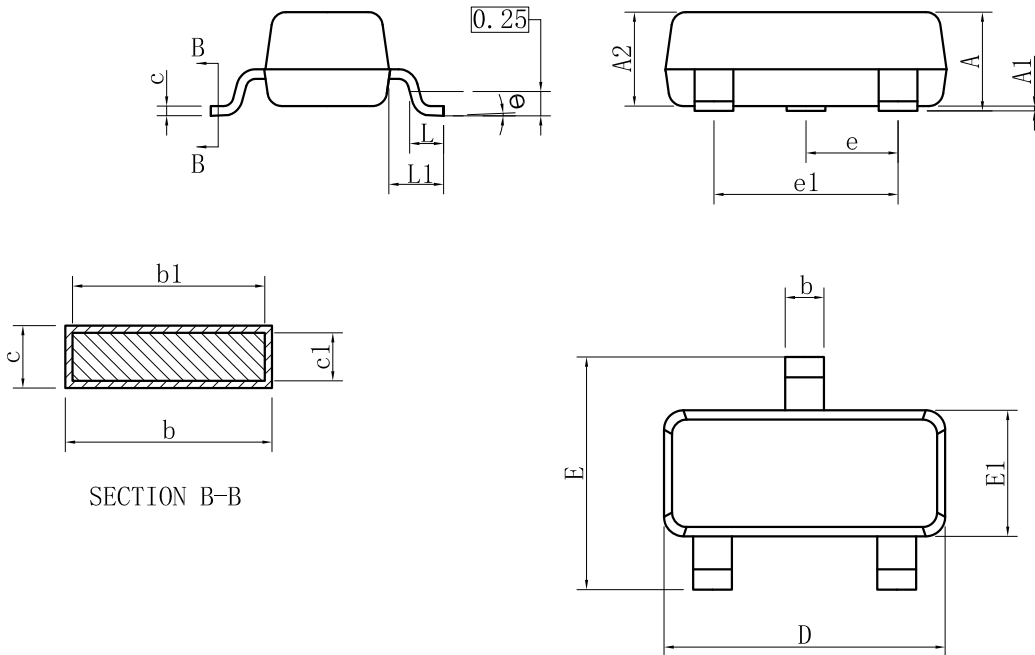

SOT23			
DIM	MIN	NOR	MAX
A	0.89	-	1.12
A1	0.01	-	0.10
A2	0.88	0.95	1.02
b	0.30	-	0.50
b1	0.30	0.40	0.45
c	0.08	-	0.20
c1	0.08	0.10	0.16
D	2.80	2.90	3.04
E	2.10	-	2.64
E1	1.20	1.30	1.40
e	0.95BSC		
e1	1.90BSC		
L	0.40	0.46	0.60
L1	0.54REF		
θ	0°	-	8°
All Dimensions in mm			

GENERAL NOTES

- 1.Top package surface finish Ra0.4±0.2um
- 2.Bottom package surface finish Ra0.7±0.2um
- 3.Side package surface finish Ra0.4±0.2um

8.SOLDERING FOOTPRINT

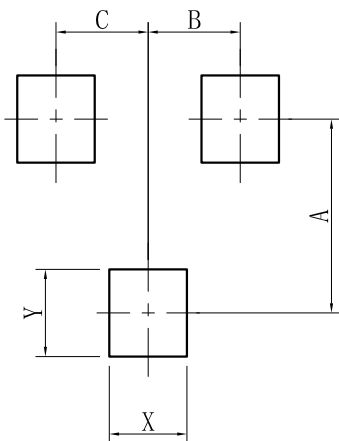

SOT-23	
DIM	(mm)
X	0.80
Y	0.90
A	2.00
B	0.95
C	0.95

DISCLAIMER

- Curve guarantee in the specification. The curve of test items with electric parameter is used as quality guarantee. The curve of test items without electric parameter is used as reference only.
- Before you use our Products for new Project, you are requested to carefully read this document and fully understand its contents. LRC shall not be in any way responsible or liable for failure, malfunction or accident arising from the use of any LRC's Products against warning, caution or note contained in this document.
- All information contained in this document is current as of the issuing date and subject to change without any prior notice. Before purchasing or using LRC's Products, please confirm the latest information with a LRC sales representative.