

Audible Signals - Industrial & Marine

IP66 BELLS

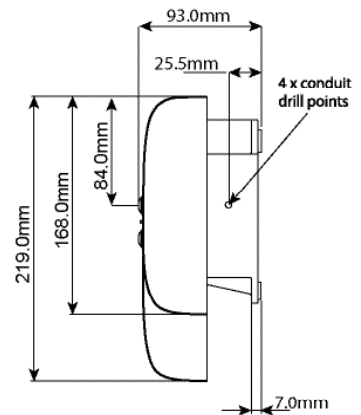
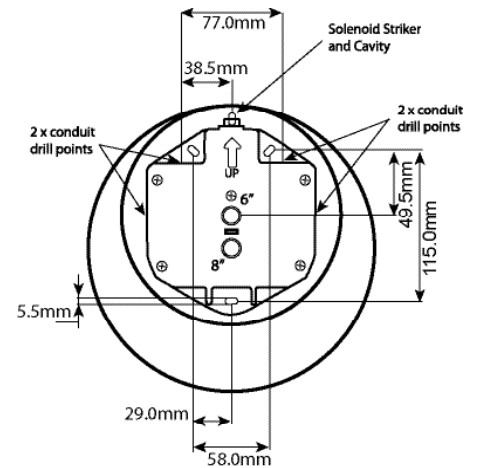

Note: Moflash Bell must be mounted in this position with the solenoid striker in the upright position. (see top diagram above)

Acoustic Signals > Industrial & Marine-IP66 Series

Product overview

The new range of 6" & 8" Solenoid driven bells have been designed and manufactured to withstand harsh environmental conditions, ideally suited for heavy duty industrial & marine applications where rugged construction and a high weatherproof classification is required.

The bells produce a rich and clear 'traditional' alarm bell sound free from mechanical clatter.

The design allows for up to 4 x M20 cabling entry knockouts, two from above & one on either side to allow for loop in/loop out cabling applications. Termination is inside the enclosure and caters for 4 x 2.5mm² cables. MED Marine approval pending.

Industrial & Marine-IP66 Series > Ordering Information

Code No:	Colour:	Voltage:	Current:
A6BM-12DC	Grey	12v Dc ---	700 mA
A6BM-24DC	Grey	24v Dc ---	400 mA
A6BM-24DCR	Red	24v Dc ---	400 mA
A6BM-24AC	Grey	24v Ac ~	500 mA
A6BM-115AC	Grey	115v Ac ~	110 mA
A6BM-230AC	Grey	230v Ac ~	60 mA
A8BM-24DC	Grey	24v Dc ---	400 mA
A8BM-24DCR	Red	24v Dc ---	400 mA
A8BM-115AC	Grey	115v Ac ~	110 mA
A8BM-230AC	Grey	230v Ac ~	60 mA

Features

- 3 point fix with adjustment slots
- Anti Tamper gong bolt
- IEC 60533:1999
Compliant for installation on ships
- EN 50130-4:2011
Compliant for Alarm systems
- Dustproof and Weatherproof

Material

UV Stable Polypropelene Back Box
Zinc Powder Coated Steel Gong

Kg 1.6 A6 Bell
2.15 A8 Bell

50/60 **Hz**

IP 66

dB 106 +/-3 A6 Bell
108 +/-3 A8 Bell

ON 10 MIN
OFF 30 MIN

INDUSTRIAL

APPROVALS and
CONFORMITIES



MARINE