

# Preliminary Specification

Note: This is a draft specification and may change.

Drawing No.	TKY1D-H2-23013-00 [14]
Issued Date.	February 1, 2023

TO: Digi-Key

Note: In case of specification change, KYOCERA Part Number also will be changed.





Product Name	Temperature Compensated Crystal Oscillator
Product Model	KT1612A
Frequency	26.0MHz
Customer Part Number	_____
Customer Specification Number	_____
KYOCERA Part Number	KT1612A26000ZAW18TFN
Remarks	RoHS Compliant, MSL=1

## Customer Acceptance

Accept Signature	Accept Date	
	Department	
	Person in charge	

Seller  
KYOCERA Corporation  
Corporate Electronic Components Group  
Electronic Components Sales Division  
6 Takeda Tobadono-cho, Fushimi-ku, Kyoto  
612-8501 Japan  
TEL. No. 075-604-3500  
FAX. No. 075-604-3501

Manufacturer  
KYOCERA Corporation  
Corporate Electronic Components Group  
RF Devices Division  
Yamagata higashine Plant  
5850, Higashine-koh, Higashine-shi, Yamagata  
999-3701 Japan  
TEL. No. 0237-43-5611  
FAX. No. 0237-43-5615

Design Department	Quality Assurance	Approved by	Examined by	Examined by	Written by
RF Devices Engineering Department Crystal Components Application Engineering Section	Y. Kakuta 	W. Muraoka 	Y. Hosoya 	F. Horie 	C. Nitobe 

KYOCERA Corporation

**Revision History**

Rev.No.	Description of revise	Date	Approved by	Examined by	Examined by	Written by
00	First Edition	February 1, 2023	W.Muraoka	Y.Hosoya	F.Horie	C.Nitoube

Preliminary

## 1. Purpose and scope

This document contains specification related to CRYSTAL OSCILLATOR model  
KT1612A26000ZAW18TFN for Digi-Key.

## 2. Nominal condition

	Item	MIN.	TYP.	MAX	Unit	Conditions
1	Operating temperature range	-40	---	+85	deg.C	
2	Storage temperature range	-40	---	+85	deg.C	
3	Nominal frequency	---	26.0	---	MHz	
4	Supply voltage	1.71	1.8	1.89	V	1.8V+/-5%
5	Absolute maximum rating voltage (Supply voltage)	-0.3	---	+4.5	V	
6	Load impedance	9	10	11	kohm	
		9	10	11	pF	
7	Output signal condition	---	Clipped sine	---	---	

## 3. Electrical characteristics

Ta= -40 to +85 deg.C, Vcc=1.8 V, Load=10kohm//10pF

	Item	MIN.	TYP.	MAX	Unit	Conditions	Remarks
1	Temp characteristics	-0.5	---	+0.5	$\times 10^{-6}$	Ta= -30 to +85 deg.C	Referenced to the mid point between minimum and maximum frequency value over the specified temperature range
		-3.0	---	+3.0	$\times 10^{-6}$	Ta= -40 to -30 deg.C	
2	Frequency Slope	-0.1	---	+0.1	$\times 10^6/\text{degC}$	Ta= -30 to +85 deg.C	Every 2 deg.C
		-0.35	---	+0.35	$\times 10^6/\text{degC}$	Ta= -40 to -30 deg.C	
3	Voltage characteristics	-0.2	---	+0.2	$\times 10^{-6}$	1.8V+/-5%	
4	Load characteristics	-0.2	---	+0.2	$\times 10^{-6}$	Load 10kohm+/-10% 10pF+/-10%	
5	Aging characteristics	-1.0	---	+1.0	$\times 10^{-6}/\text{Y}$	1year	at 25+/-2 deg.C
6	Frequency tolerance	-2.0	---	+2.0	$\times 10^{-6}$	After 2 times reflow soldering	at 25+/-2 deg.C
7	Current	---	---	2.0	mA		
8	Output voltage	0.8	---	---	Vp-p		
9	Harmonics	---	---	-8.0	dBc		
10	Start up time	---	---	2.0	msec	90% of final output amplitude	
		---	---	2.0	msec	Within +/-0.5ppm	
11	Temperature hysteresis	-0.6	---	+0.6	$\times 10^{-6}$		
12	Phase noise	---	-62	---	dBc/Hz	@1Hz offset	at 25+/-2 deg.C
		---	-91	---	dBc/Hz	@10Hz offset	
		---	-117	---	dBc/Hz	@100Hz offset	
		---	-137	---	dBc/Hz	@1kHz offset	
		---	-151	---	dBc/Hz	@10kHz offset	
		---	-157	---	dBc/Hz	@100kHz offset	

Note. There is possibility to change standard values of electrical characteristics

## 4. Circuit

Bypass Capacitor and DC- Blocking Capacitor do not build in this TCXO.  
So, Bypass Capacitor and DC- Blocking Capacitor are attached outside and please use it.  
And these Capacitor should be placed as close as possible to the pin(No.3 and No.4).

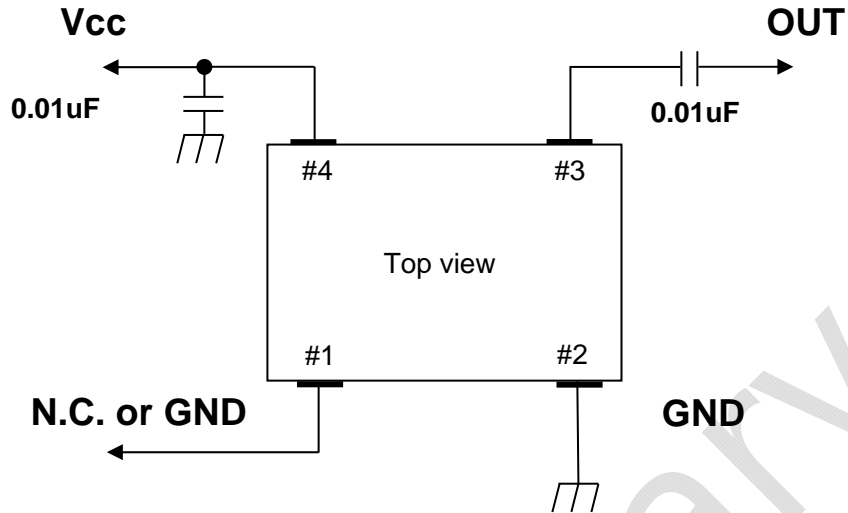

## 5. Test circuit

\*Load 10kohm//10pF contains the internal impedance of FET probe.

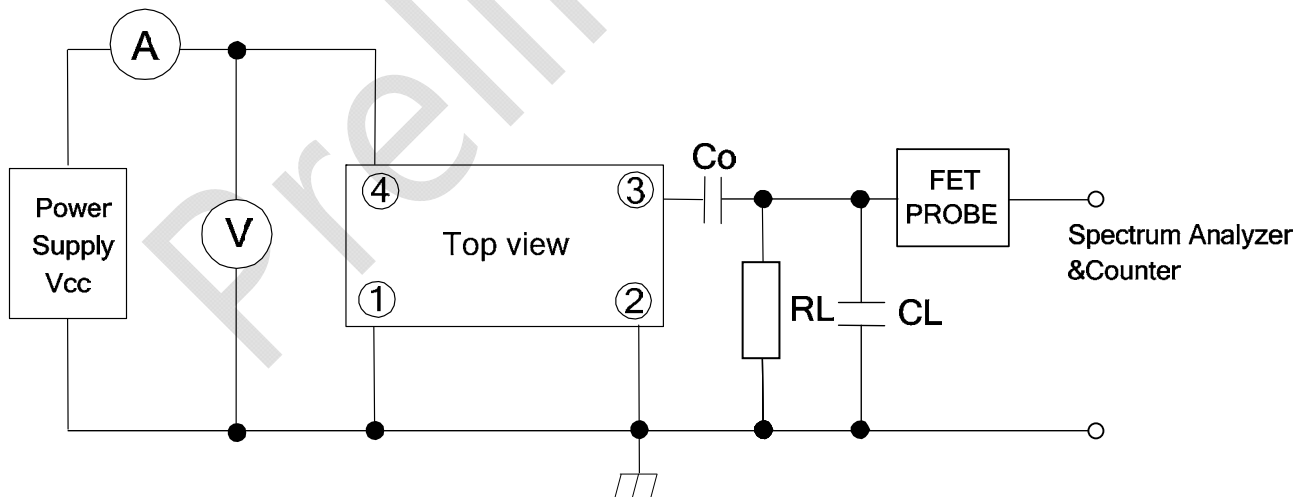

## 6. Environment mechanical characteristics

	Item	Conditions	Remark
1	High temperature storage	Ta=+85deg.C, judge on 240H storage	It must be met to the characteristics Judging criterion. Measurement shall be taken at room ambient within 2 to 24hours after each test.
2	Low temperature storage	Ta=-40deg.C, judge on 240H storage	
3	High temperature and high humidity storage	Ta=+85deg.C, RH=85%RH, judge on 240H storage	
4	Temperature cycle test	Ta=-40 to +85deg.C 30min. each 10cycles	
5	Drop test	A test piece (100g) made of Teflon is dropped 3cycles (1cycle: 6 directions) from the height of 150cm on hard board	
6	Vibration test	10 to 55 to 10Hz 1.5mm constant amplitude 1min. period X, Y, Z direction each 2H total 6H.	
7	Solder heat test	All terminal electrode shall be soldered at temperature of 350+/-5deg.C for 3+/-1sec. using a soldering iron.	
8	Solderability	Dip each of terminal electrode into 230+/-5deg.C solder pod for 5+/-0.5sec. after close, the test area of loads surfaces must be covered loads 90% by solder.	
9	Reflow soldering	Reflow soldering at 2 times.	

Normal Condition: Temperature 25+/-2deg.C  
Humidity 30 to 70%RH

Judge

Item	Specification
At 25deg.C frequency	+/-2.0ppm max(Before and After)

## 7. Reflow profile

7-1. Preheat:  $180 \pm 0/-10$ deg.C, 120sec (max)7-2. Peak Temperature:  $260 \pm 0/-10$ deg.C, 10sec (max)

7-3. PC-Board

Material : FR-4

Size : 140mm\*110mm

Thickness :  $t=0.8$ mm

7-4. Condition of Measurement Temperature: Surface of PC-BOARD

## Reflow Soldering Condition

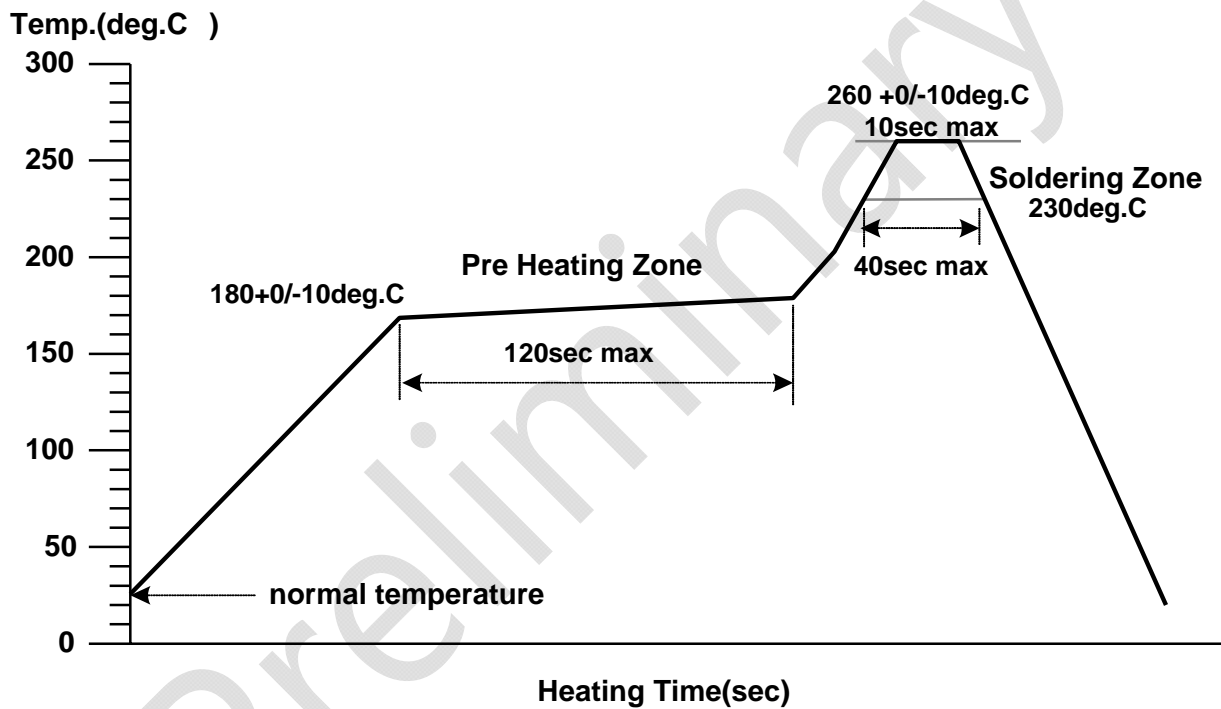

## 8. Marking contents

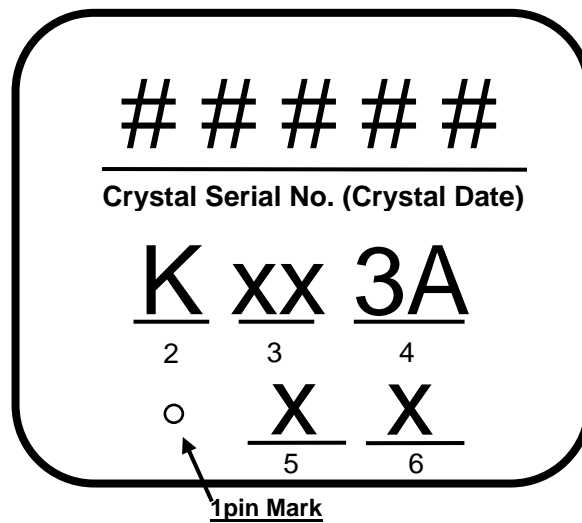

\*Laser Marking

	Contents	Example
1	Pin-1 identifier	○
2	Control Code1	K
3	Control Code2	xx
4	Monthly Code	3A *The 2023 January 3B *The 2023 February
5	Control Code3	x *Specification Code ( “—” mark or nothing)
6	Control Code4	x *Specification Code ( “○” mark or nothing)

9. Dimensions

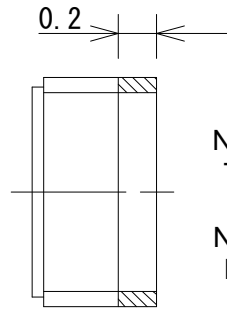
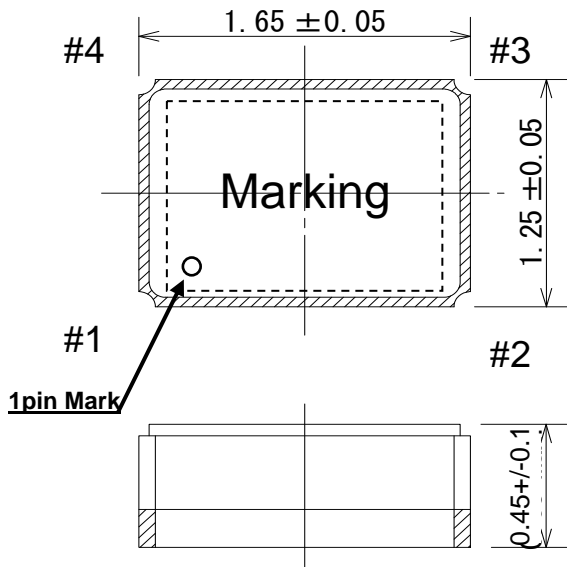

Note1  
Terminal Coplanarity: 60um max

Note2  
Electrode: Mo + Ni 1.5 to 8.89um  
+ Au 0.3 to 1.0um

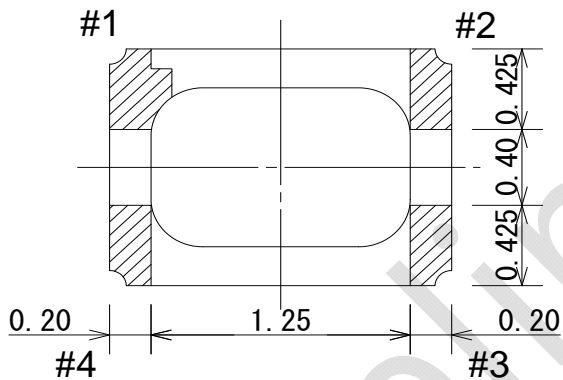

	Pin Connection
#1 pin	GND or N.C.
#2 pin	GND
#3 pin	Output
#4 pin	Vcc

Unit: mm

Recommended Land Pattern

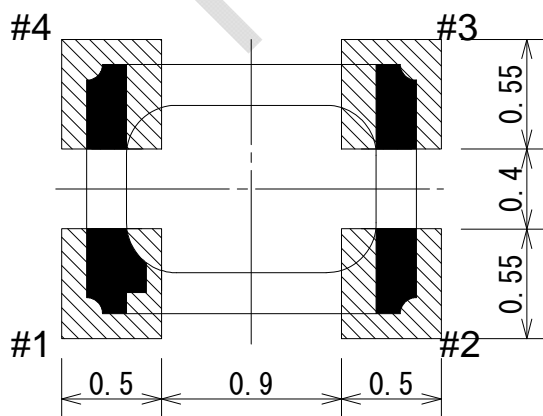



9. Tape & Reel

9-1. Tape specification

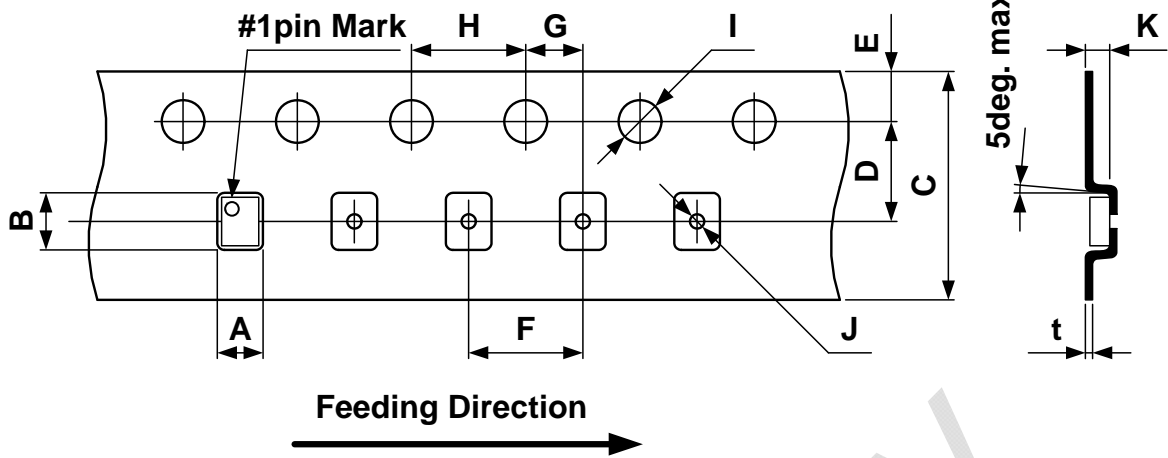

9-1-1. Carrier Tape material: PS Included Carbon

9-1-2. #1pin Mark is positioned on right side against the direction of feed.

Unit: mm

Symbol	A	B	C	D	E
Dimension	1.45+/-0.1	1.85+/-0.1	8.0+/-0.2	3.5+/-0.05	1.75+/-0.1

Symbol	F	G	H	I	J
Dimension	4.0+/-0.1	2.0+/-0.05	4.0+/-0.05	Φ1.5+0.1/-0	Φ0.5+0.05

Symbol	K	t
Dimension	0.65+/-0.05	0.20+/-0.05

9-2. Reel specification

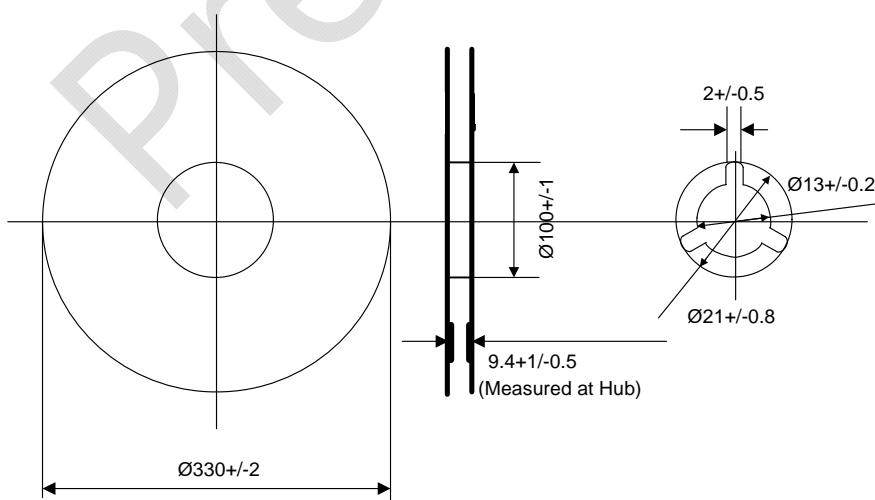

Unit: mm

9-2-1. Reel material: PS Included Carbon

9-2-2. Reel unit: 18,000pcs max. /1Reel

### 9-3. Packing

#### 9-3-1. Trailer & Leader

As for the trailer and leader of taping, there are empty pockets as following drawing.  
Sprocket hole is positioned on upper side against the direction of feed.  
No missing components, excluding empty place.

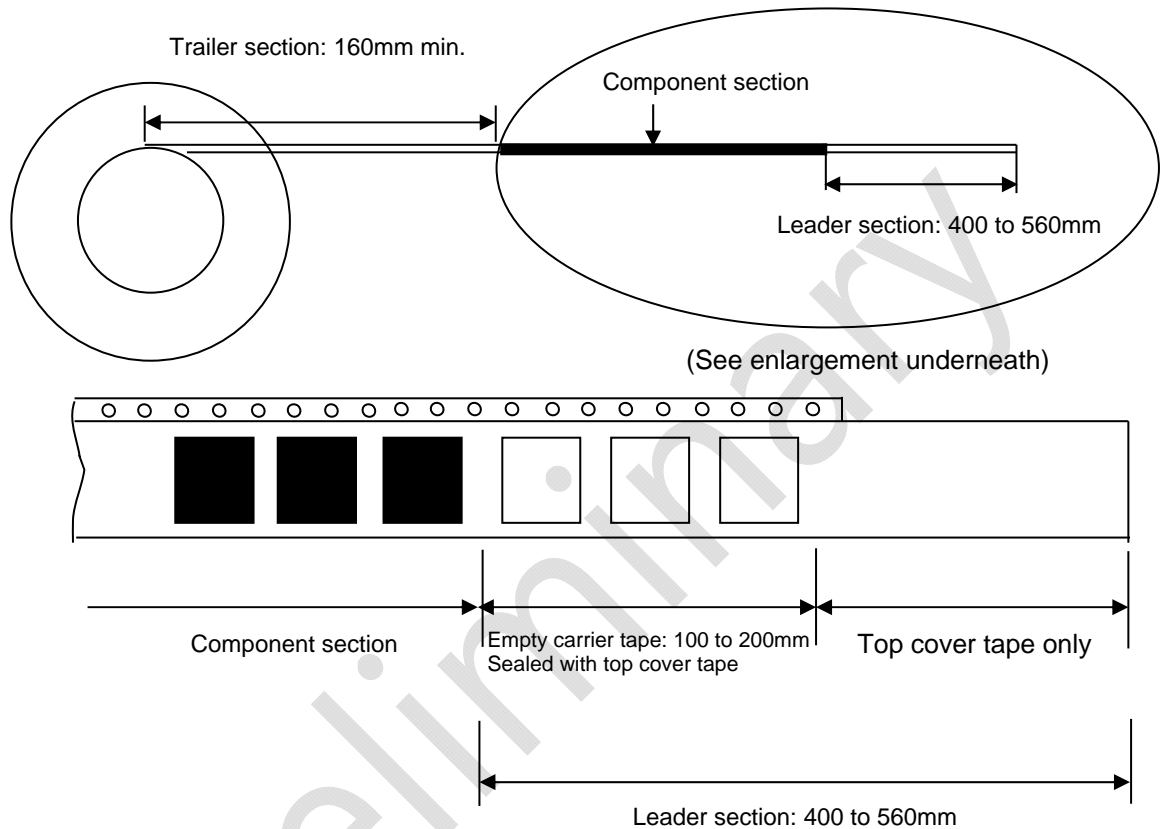

### 9-4. Shipping label

Following item shall be listed on reel, bag and box.

“Customer’s name”, “Parts No”, “Lot No”, “Quantity”, “Order No”, “Date of manufacture”  
The form of the label conforms to JEITA standard pattern C-3.

## 10. Top cover breaking and peeling force

10-1. Reel Angle: 165 to 180deg

10-2. Tape Break Force: 10N min

10-3. Top Cover Tape Strength: 10N min

10-4. Top Cover Tape Peel Force: 0.1 to 1.0N

10-5. Top Cover Tape Peel Speed: 300+/-10mm / minute

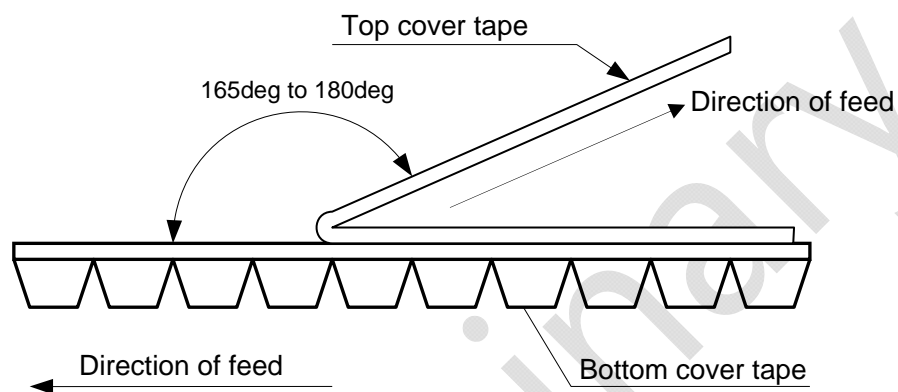

## 11. Notice

11-1. Please use soldering iron and the spot heater within the range of a solder heat test

11-2. Units should be stored in a dry environment keeping away from the sun.

11-3. Don't leave units in High-temperature and High-humidity environment due to terminal solderability. (Please keep 0 to 40deg.C and 30 to 70%RH for recommendable storage condition.)

11-4. The term of a guarantee of taping packing is 6 months.  
(0 deg.C to 40 deg.C,RH30% to 70%)

11-5. Disapprove of washing.

11-6. Please contact us if you are considering molding by transfer or compression.

11-7. Unless we receive request for modification within 1 month from the issue date of this KC specification sheet, we will supply products according to this specification.  
Also, if you'd like to modify specification of order, which has been placed with delivery within 1 month from the issue data of this specification sheet, we would like to discuss with you separately.

11-8. This product can be used for general electronic equipment (information equipment, communication equipment, audiovisual equipment, measuring equipment, home appliances, etc.)Intended to be used.Equipment and systems (traffic equipment, safety equipment, aviation / space control, nuclear power control, life support equipment, base station ) that require special quality and reliability and whose failure or malfunction may endanger human life or harm the human body. (Including medical devices, etc.), basic driving functions (running, turning, stopping) and collision safety in traffic equipment, applications related directly or indirectly to collision safety, and applications that are expected to have a significant impact on property, etc. It is not intended to be used.In the unlikely event that this product is used for any of these purposes, we will not be liable for any damages resulting from such use.

11-9. In no event shall the company be liable for any product failure resulting from an inappropriate handling or operation of the product beyond the scope of its guarantee.

11-10. Information contained in this specification must not be quoted, reproduced or used for other purposes including processing either in part or in full without obtaining prior approval from the company.

11-11. Please keep it at the place that was the ESD protective.

Human model    1.5kohm 100pF : +/-1000V

Machine model    0kohm 200pF : +/-200V

## 12. Production place

## 12-1. Manufacturer

KYOCERA Corporation.

## 12-2. The site of the Factory

5850 Higashine-Koh, Higashine-shi, Yamagata, 999-3701, Japan  
 158-15 Chuo-kogyo-danchi, Sagae-shi, Yamagata, 991-0061, Japan  
 115-1 Jinmachi-aza-nishihara, Higashine-shi, Yamagata, 999-3761, Japan

## 13. Quality guarantee

In case when Kyocera Corporation rooted failure occurred within 1year after its delivery, substitute product will be arranged based on discussion. Quality guarantee of product after 1year of its delivery is waived.

## 14. Parts Numbering Guide

**KT1612A 26000 Z A W 18 T FN**  
 A B C D E F G H

- A. Series (1.6x1.2 SMD KT1612A)
- B. Frequency (26.0MHz)
- C. Frequency temperature accuracy ( Z: Special specification)
- D. Minimum temperature range ( A: -40deg.C)
- E. Maximum temperature range ( W: +85deg.C)
- F. Supply voltage (18: 1.8V)
- G. Control voltage stability (T: TCXO)
- H. Customer special model Suffix