



# SGM7300A/SGM7300B

## 3.3V, Differential 2-Channel, 2:1 Multiplexer/Demultiplexer Switches

### GENERAL DESCRIPTION

The SGM7300A/SGM7300B are differential 2-channel switches which can be used for both multiplexer (MUX) and demultiplexer (DEMUX) configurations. The devices can be used for PCI Express Generation 3, USB 3.1 and other high-speed serial interface applications.

The products can switch dual differential signals to 1 of 2 locations. Using these design techniques, SGMICRO minimizes the impedance of the switch so that the attenuation observed through the switch can be ignored and minimizes the inter-channel skew and inter-channel crosstalk required for high-speed serial interfaces. The SGM7300A and SGM7300B can achieve extremely low power consumption by extending existing high-speed ports. In order to achieve high ESD tolerance, The ESD protection circuits are integrated into ICs.

SGMICRO optimizes the pins to match the product to different application layouts. The SGM7300A is suitable for edge connectors with different signal sources on the motherboard, with input and output pins on opposite sides of the package. The SGM7300B can be placed between two connectors to multi-channel differential signals from the controller, with output pins on both sides of the package.

No external DC blocking capacitors are required on the RF paths as long as no external DC voltage is applied, which can save PCB area and cost.

The SGM7300A and SGM7300B both are available in a Green TLGA-2.5×4.5-20L package.

### FEATURES

- **Low Insertion Loss:**
  - ◆ -0.35dB at 0.1GHz
  - ◆ -0.90dB at 4.0GHz
- **Low Off-State Isolation: -22dB at 4.0GHz**
- **Low Return Loss: -20dB at 4.0GHz**
- **Available in a Green TLGA-2.5×4.5-20L Package**

### APPLICATIONS

USB 3.1  
 PCI Express Generation 3  
 DisplayPort 1.2  
 SATA 6Gbit/s  
 High-Speed Differential Signals Routing

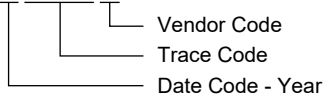
**PACKAGE/ORDERING INFORMATION**

MODEL	PACKAGE DESCRIPTION	SPECIFIED TEMPERATURE RANGE	ORDERING NUMBER	PACKAGE MARKING	PACKING OPTION
SGM7300A	TLGA-2.5x4.5-20L	-40°C to +85°C	SGM7300AYTLN20G/TR	MET TLN20 XXXXX	Tape and Reel, 5000
SGM7300B	TLGA-2.5x4.5-20L	-40°C to +85°C	SGM7300BYTLN20G/TR	05N TLN20 XXXXX	Tape and Reel, 5000

**MARKING INFORMATION**

NOTE: XXXXX = Date Code, Trace Code and Vendor Code.

**XXXXX**



Green (RoHS & HSF): SG Micro Corp defines "Green" to mean Pb-Free (RoHS compatible) and free of halogen substances. If you have additional comments or questions, please contact your SGMICRO representative directly.

**ABSOLUTE MAXIMUM RATINGS**

Supply Voltage, $V_{DD}$ .....	-0.3V to 3.7V
Junction Temperature.....	+150°C
Storage Temperature Range.....	-55°C to +150°C
Lead Temperature (Soldering, 10s).....	+260°C
ESD Susceptibility	
HBM.....	1000V
CDM.....	2000V

**RECOMMENDED OPERATING CONDITIONS**

Operating Temperature Range.....	-40°C to +85°C
Supply Voltage, $V_{DD}$ .....	3.0V to 3.6V

**OVERSTRESS CAUTION**

Stresses beyond those listed in Absolute Maximum Ratings may cause permanent damage to the device. Exposure to absolute maximum rating conditions for extended periods may affect reliability. Functional operation of the device at any conditions beyond those indicated in the Recommended Operating Conditions section is not implied.

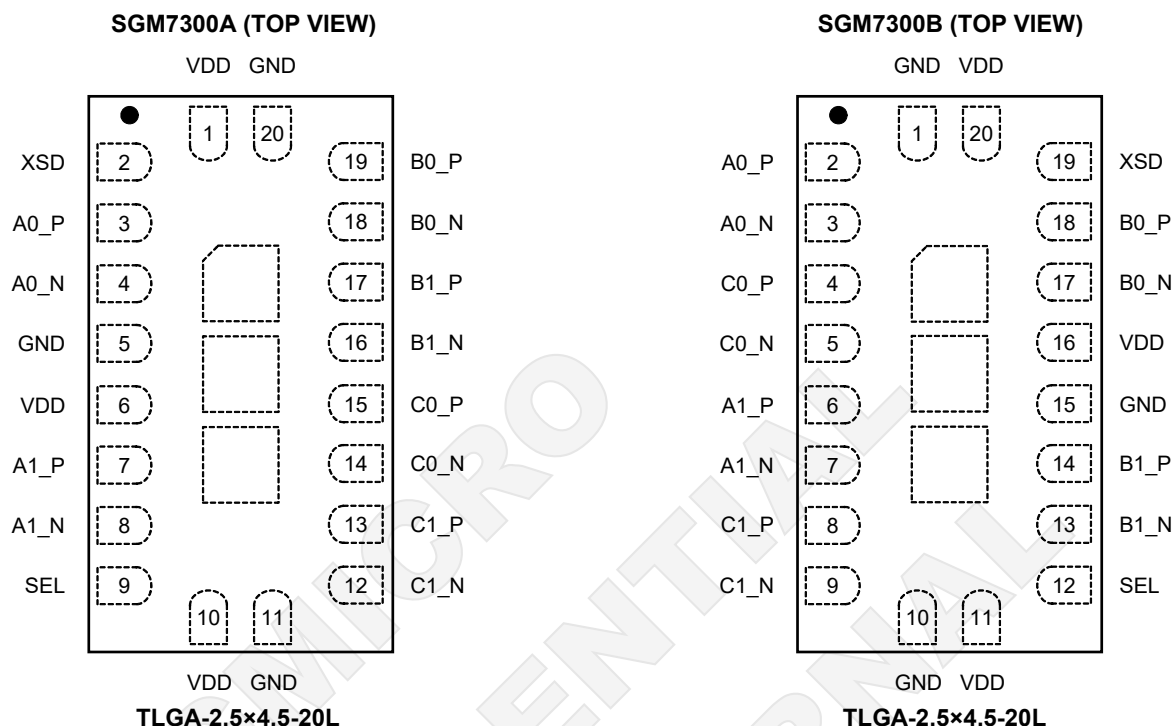
**ESD SENSITIVITY CAUTION**

This integrated circuit can be damaged if ESD protections are not considered carefully. SGMICRO recommends that all integrated circuits be handled with appropriate precautions. Failure to observe proper handling and installation procedures can cause damage. ESD damage can range from subtle performance degradation to complete device failure. Precision integrated circuits may be more susceptible to damage because even small parametric changes could cause the device not to meet the published specifications.

**DISCLAIMER**

SG Micro Corp reserves the right to make any change in circuit design, or specifications without prior notice.

**PIN CONFIGURATIONS**



**PIN DESCRIPTION**

PIN		NAME	TYPE	FUNCTION
SGM7300A	SGM7300B			
3	2	A0_P	I/O	Channel 0, Port A, Positive/Negative Signal.
4	3	A0_N	I/O	
7	6	A1_P	I/O	Channel 1, Port A, Positive/Negative Signal.
8	7	A1_N	I/O	
19	18	B0_P	I/O	Channel 0, Port B, Positive/Negative Signal.
18	17	B0_N	I/O	
17	14	B1_P	I/O	Channel 1, Port B, Positive/Negative Signal.
16	13	B1_N	I/O	
15	4	C0_P	I/O	Channel 0, Port C, Positive/Negative Signal.
14	5	C0_N	I/O	
13	8	C1_P	I/O	Channel 1, Port C, Positive/Negative Signal.
12	9	C1_N	I/O	
9	12	SEL	CMOS Single-Ended Input	Operation Mode Select Pin. SEL = Low: A ↔ B SEL = High: A ↔ C
2	19	XSD	CMOS Single-Ended Input	XSD = Low: Normal Operation XSD = High: Shutdown Operation
1, 6, 10	11, 16, 20	VDD	Power	Positive Supply Voltage.
5, 11, 20	1, 10, 15	GND	Power	Ground.
Exposed Pad		GND	Power	Ground. Exposed pad must be connected to ground.

**BLOCK DIAGRAM**

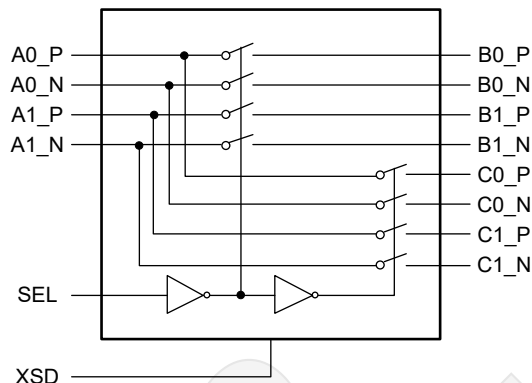


Figure 1. SGM7300A/SGM7300B Block Diagram

**FUNCTIONAL DESCRIPTION**

XSD	SEL	FUNCTION
High	X	All channel off
Low	Low	Channel on An to Bn
Low	High	Channel on An to Cn

X = Don't care

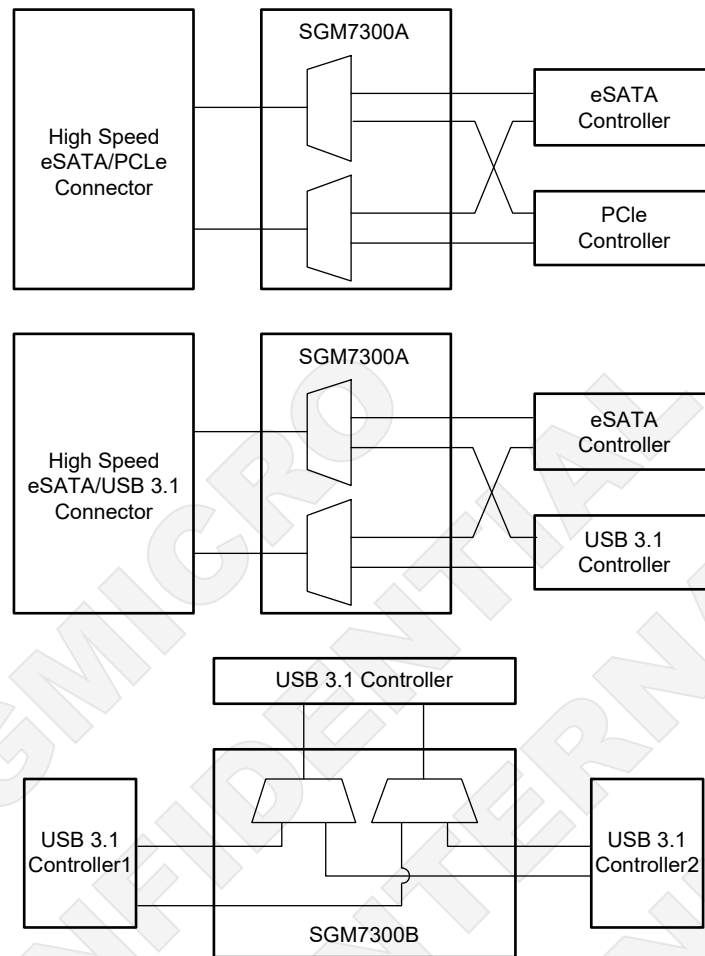
SGMICRO CONFIDENTIAL FOR INTERNAL USE ONLY

**ELECTRICAL CHARACTERISTICS**

(T<sub>A</sub> = +25°C, V<sub>DD</sub> = 3.3V ± 10%, typical values are at V<sub>DD</sub> = 3.3V, and maximum loading, unless otherwise noted.)

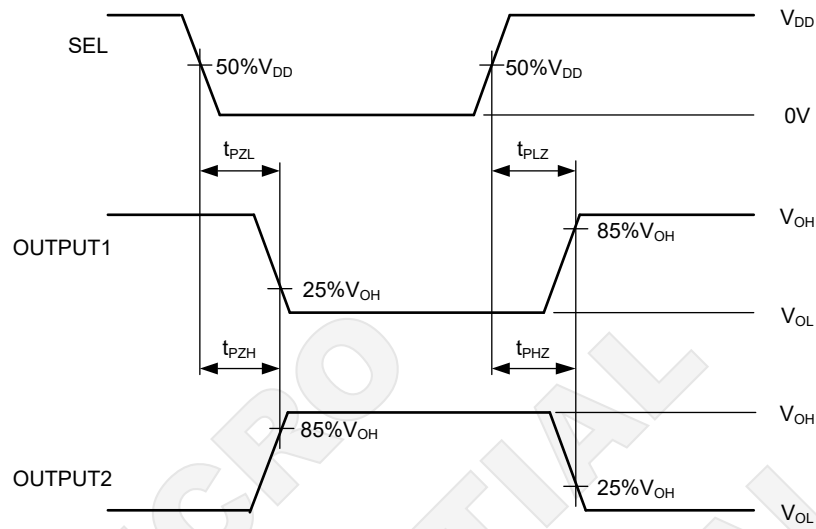
PARAMETER	SYMBOL	CONDITIONS	MIN	TYP	MAX	UNITS
<b>Static Characteristics</b>						
Supply Current	I <sub>VDD</sub>	Normal mode, V <sub>DD</sub> = max, XSD = low		80	120	μA
		Shutdown mode, V <sub>DD</sub> = max, XSD = high		80	120	
High-Level Input Current	I <sub>IH</sub>	V <sub>DD</sub> = max, V <sub>I</sub> = V <sub>DD</sub>			±25	μA
Low-Level Input Current	I <sub>IL</sub>	V <sub>DD</sub> = max, V <sub>I</sub> = GND			±25	μA
High-Level Input Voltage	V <sub>IH</sub>	SEL, XSD pins	1.35			V
Low-Level Input Voltage	V <sub>IL</sub>	SEL, XSD pins			0.45	V
Input Voltage	V <sub>IN</sub>	Differential pins			2.4	V
		SEL, XSD pins			V <sub>DD</sub>	
Common-Mode Input Voltage	V <sub>IC</sub>		0		2	V
Differential Input Voltage	V <sub>ID</sub>	Peak to peak			1.6	V
<b>Dynamic Characteristics</b>						
Differential Insertion Loss	DDIL	Channel is off	f <sub>0</sub> = 0.1GHz		-50	dB
			f <sub>0</sub> = 4.0GHz		-22	
		Channel is on	f <sub>0</sub> = 0.1GHz		-0.35	
			f <sub>0</sub> = 4.0GHz		-0.90	
Differential Near-End Crosstalk	DDNEXT	Adjacent channels are on	f <sub>0</sub> = 0.1GHz		-60	dB
			f <sub>0</sub> = 4.0GHz		-30	
-3dB Bandwidth	B <sub>-3dB</sub>			10		GHz
Differential Return Loss	DDRL	f <sub>0</sub> = 4.0GHz		-20		dB
		f <sub>0</sub> = 0.1GHz		-30		
On-State Resistance	R <sub>ON</sub>	V <sub>DD</sub> = 3.3V, V <sub>IN</sub> = 2V, I <sub>IN</sub> = 19mA		5		Ω
On-State Input/Output Capacitance	C <sub>IO_ON</sub>			1.5		pF
Propagation Delay	t <sub>PD</sub>	An to Bn or An to Cn		100		ps
<b>Switching Characteristics</b>						
Start-Up Time	t <sub>STARTUP</sub>	VDD valid and XSD is low			20	μs
Off-State to High Propagation Delay	t <sub>PZH</sub>				200	ns
Off-State to Low Propagation Delay	t <sub>PZL</sub>				80	ns
High to Off-State Propagation Delay	t <sub>PHZ</sub>				80	ns
Low to Off-State Propagation Delay	t <sub>PLZ</sub>				200	ns
Differential Skew Time	t <sub>SK(DIF)</sub>	Intra-pair		10		ps
Skew Time	t <sub>SK</sub>	Inter-pair			50	ps

**TYPICAL APPLICATION CIRCUITS**

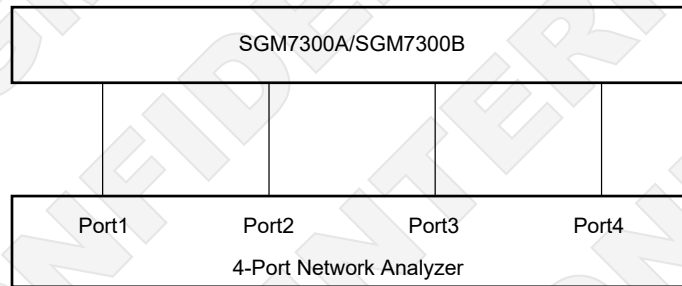


**Figure 2. SGM7300A/SGM7300B Typical Application Circuits**

**VOLTAGE WAVEFORMS**



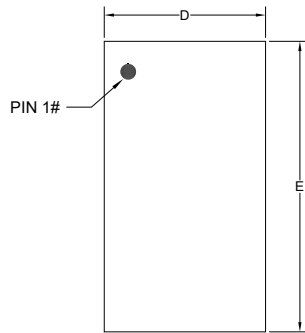
**Figure 3. SGM7300A/SGM7300B Voltage Waveforms for Enable and Disable Times**



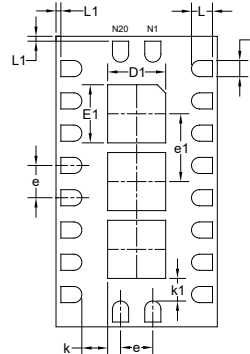
**Figure 4. SGM7300A/SGM7300B Test Circuit**

PACKAGE OUTLINE DIMENSIONS

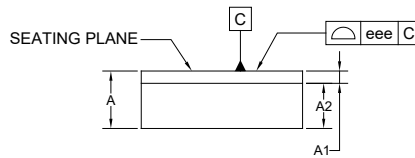
TLGA-2.5×4.5-20L



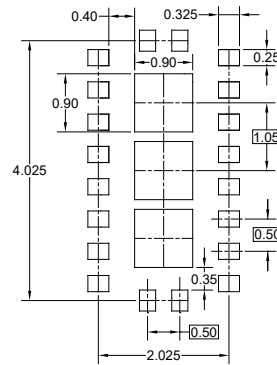
TOP VIEW



BOTTOM VIEW



SIDE VIEW



RECOMMENDED LAND PATTERN (Unit: mm)

Symbol	Dimensions In Millimeters		
	MIN	MOD	MAX
A	0.840	-	0.940
A1	0.160	-	0.220
A2	0.700 REF		
b	0.200	-	0.300
D	2.400	-	2.600
E	4.400	-	4.600
D1	0.800	0.900	1.000
E1	0.800	0.900	1.000
e	0.500 BSC		
e1	1.050 BSC		
L	0.275	-	0.375
L1	0.025	-	0.125
k	0.400 REF		
k1	0.350 REF		
eee	0.100		

NOTE: This drawing is subject to change without notice.



TAPE AND REEL INFORMATION

REEL DIMENSIONS



TAPE DIMENSIONS



NOTE: The picture is only for reference. Please make the object as the standard.

KEY PARAMETER LIST OF TAPE AND REEL

Package Type	Reel Diameter	Reel Width W1 (mm)	A0 (mm)	B0 (mm)	K0 (mm)	P0 (mm)	P1 (mm)	P2 (mm)	W (mm)	Pin1 Quadrant
TLGA-2.5×4.5-20L	13"	12.4	2.75	4.75	1.00	4.0	8.0	2.0	12.0	Q1

000001

# PACKAGE INFORMATION

## CARTON BOX DIMENSIONS



NOTE: The picture is only for reference. Please make the object as the standard.

## KEY PARAMETER LIST OF CARTON BOX

Reel Type	Length (mm)	Width (mm)	Height (mm)	Pizza/Carton
13"	386	280	370	5

DD0002