

STM

Integrated Steppers



The STM is an integrated **Drive+Motor**, fusing step motor and drive technologies into a single device, offering savings on space, wiring and cost over conventional motor and drive solutions.



Models

- | | |
|-----------|---|
| R | <ul style="list-style-type: none"> Pulse & direction, CW/CCW pulse |
| S | <ul style="list-style-type: none"> Pulse & direction, CW/CCW pulse, A/B quadrature Velocity (oscillator) mode Streaming commands (SCL compatible) ST Configurator™ software for setup |
| Q | <ul style="list-style-type: none"> Executes stored Q programs Networking with RS-485 or Ethernet options Conditional processing & multi-tasking Math functions, register manipulation Encoder following Third-party HMI compatibility |
| C | <ul style="list-style-type: none"> CANopen protocols DS301 and DSP402 Profile Position, Profile Velocity, and Homing modes Up to 127 axes per channel Executed stored Q programs |
| IP | <ul style="list-style-type: none"> EtherNet/IP industrial networking Same control modes as Q model |



- ✓ **Dynamic Current Control**
- ✓ **Anti-Resonance**
- ✓ **Torque Ripple Smoothing**
- ✓ **Microstep Emulation**
- ✓ **Stall Prevention/Detection**

For more information visit: www.applied-motion.com/STM

STM17

Integrated Stepper



- NEMA 17 frame size
- Torque: up to 68 oz-in
- Input voltage: 12-48 VDC



STM17 Dimensions

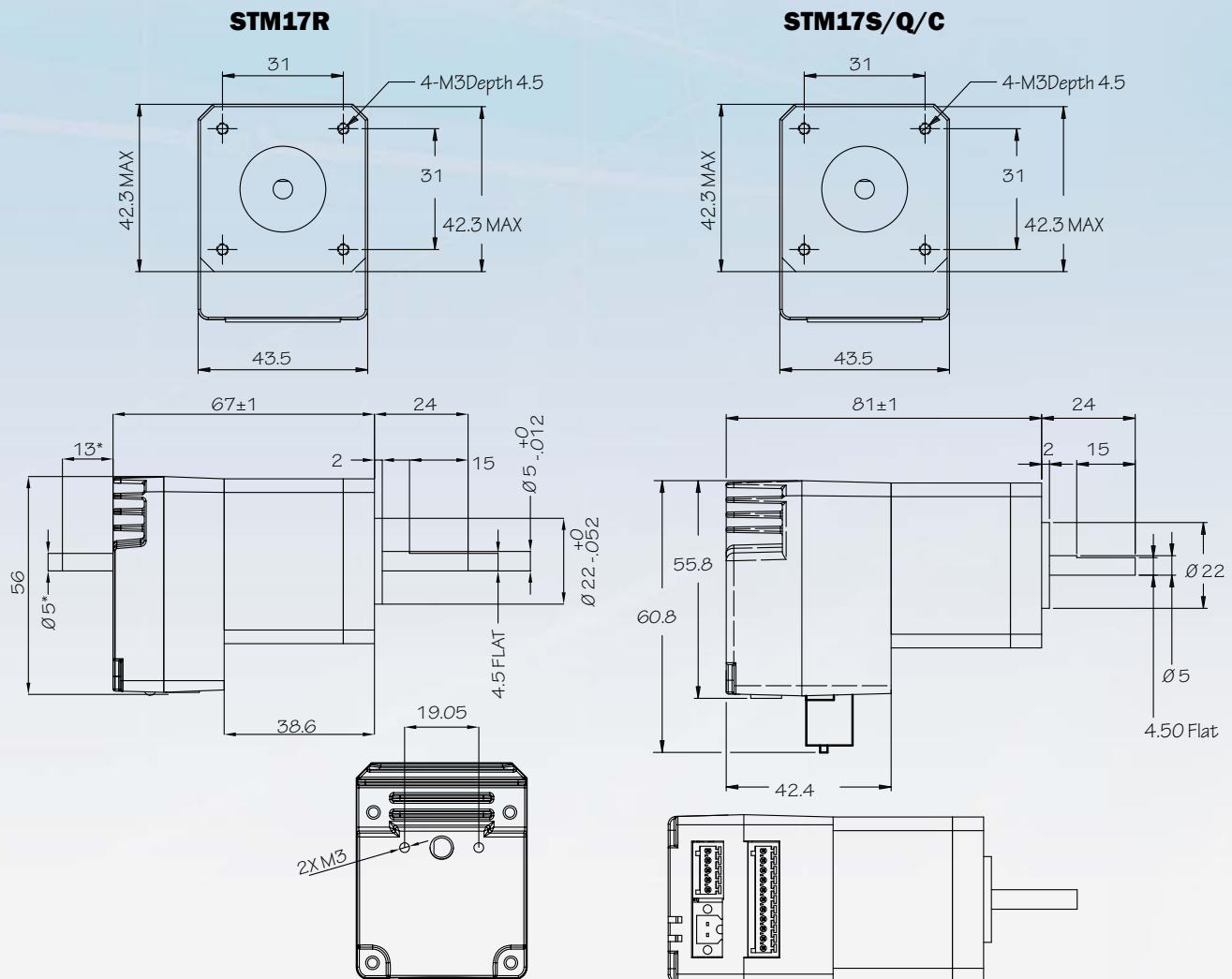

Dimensions in mm, not to scale
 *rear shaft is only present on -ND and -NE versions

STM17 Torque Curves

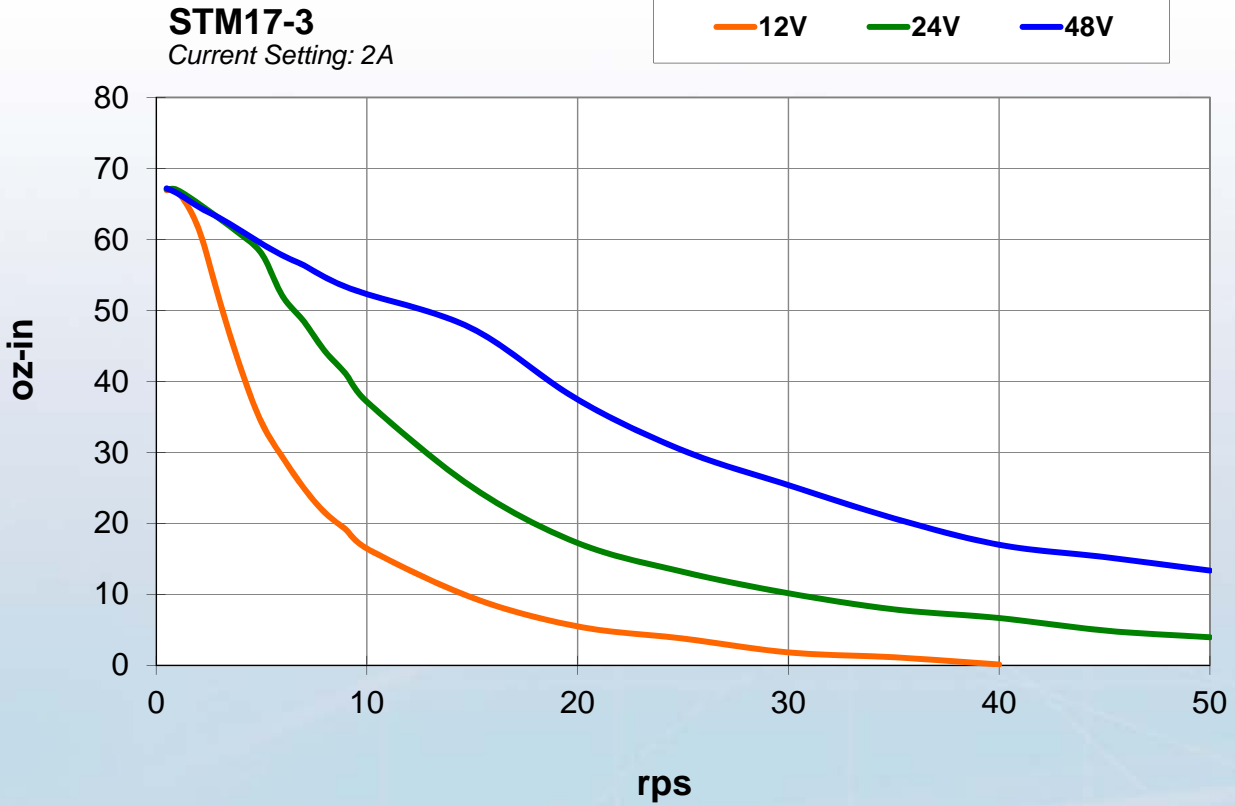

I/O Connections

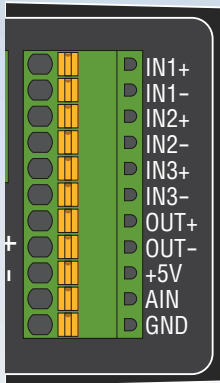

C

3 digital inputs
1 digital output
1 analog input

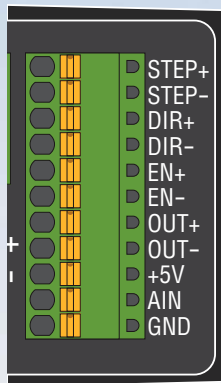

S

3 digital inputs
1 digital output
1 analog input

Q

3 digital inputs
1 digital output
1 analog input

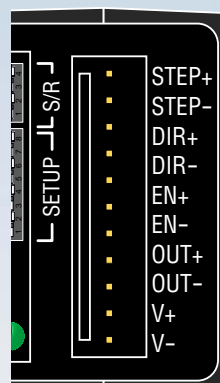

R

3 digital inputs
1 digital output



STM17 Technical Specifications

POWER AMPLIFIER:

AMPLIFIER TYPE	Dual H-bridge, 4 quadrant
CURRENT CONTROL	4 state PWM at 16 kHz
OUTPUT TORQUE	Up to 68 oz-in with suitable power supply
POWER SUPPLY	External 12 - 48 VDC power supply required Under-voltage alarm: 11 VDC Over-voltage shutdown: 52 VDC
PROTECTION	Over-voltage, under-voltage, over-temp, motor/wiring shorts (phase-to-phase, phase-to-ground)
IDLE CURRENT REDUCTION	STM17S/Q/C: Reduction range of 0 - 90% of running current after delay selectable in milliseconds. STM17R: Switch selectable 50% or 90% of running current.

CONTROLLER:

MICROSTEP RESOLUTION	STM17S/Q/C: Software selectable from 200 to 51200 steps/rev in increments of 2 steps/rev. STM17R: Dip-switch selectable 200, 400, 800, 1000, 1600, 2000, 3200, 4000, 5000, 6400, 8000, 10000, 12800, 20000, 25000 or 25600 steps/rev.
MICROSTEP EMULATION	Performs high resolution stepping by synthesizing fine microsteps from coarse steps (step & direction mode only)
COMMAND SIGNAL SMOOTHING	Software configurable filtering reduces jerk and excitation of extraneous system resonances (step & direction mode)
ANTI-RESONANCE (Electronic Damping)	Raises the system damping ratio to eliminate midrange instability and allow stable operation throughout the speed range and improves settling time
AUTO SETUP	Measures motor parameters and configures motor current control and anti-resonance gain settings
SELF TEST	Checks internal & external power supply voltages, diagnoses open motor phases
NON-VOLATILE STORAGE	Configurations are saved in flash memory on-board the DSP
MODES OF OPERATION	STM17R: Step & direction or CW/CCW pulse (switch selectable) STM17S: Step & direction, CW/CCW pulse, A/B quadrature pulse, velocity (oscillator, joystick), streaming commands (SCL) STM17Q: All STM17S modes of operation plus stored Q program execution STM17C: CANopen slave node plus stored Q program execution
DIGITAL INPUTS	<i>Adjustable bandwidth digital noise rejection filter on all inputs</i> STEP+/- (IN1+/-): Optically isolated, 5-24 volt. Minimum pulse width = 250 ns. Maximum pulse frequency = 3 MHz. Function: STM17R: Step, CW pulse; All others: Step, CW pulse, A quadrature (encoder following), CW limit, CW jog, start/stop (oscillator mode), or general purpose input. DIR+/- (IN2+/-): Optically isolated, 5-24 volt. Minimum pulse width = 250 ns. Maximum pulse frequency = 3 MHz. Function: STM17R: Direction, CCW pulse; All others: Direction, CCW pulse, B quadrature (encoder following), CCW limit, CCW jog, direction (oscillator mode), or general purpose input. EN+/- (IN3+/-): Optically isolated, 5-24 volt. Minimum pulse width = 250 ns. Maximum pulse frequency = 3 MHz. Function: STM17R: Enable; All others: Enable, alarm/fault reset, speed 1/speed 2 (oscillator mode).
DIGITAL OUTPUT	OUT+/-: Optically isolated, 30V/40mA max. Function: STM17R: Fault; All others: Fault, motion, tach, or general purpose programmable.
ANALOG INPUT	STM17S/Q/C: AIN referenced to GND. Range = 0 to 5 VDC. Resolution = 12 bits. STM17R: No analog input
COMMUNICATION INTERFACE	STM17x-3Ax: RS-232 STM17x-3Rx: RS-485 STM17C-3Cx: CANopen and RS-232 STM17R-3Nx: No communication port

APPROVALS:

AGENCY APPROVALS	RoHS, CE EN61800-3:2004
------------------	-------------------------

PHYSICAL:

OPERATING TEMPERATURE	0 to 85 °C (32 to 185 °F) Internal temperature of the electronics section and encoder 0 to 100 °C (32 to 212 °F) Temperature of motor body
AMBIENT TEMPERATURE	0 to 40 °C (32 to 104 °F) When mounted to a suitable heatsink
HUMIDITY	90% max, non-condensing
MASS	STM17R: 14.7 oz (416 g); STM17S/Q/C: 15.6 oz (441 g)
ROTOR INERTIA	1.16×10^{-3} oz-in-sec ² (82 g-cm ²)

STM23

Integrated Stepper



- NEMA 23 frame size
- Torque: up to 210 oz-in
- Input voltage: 12-70 VDC



STM23 Dimensions

STM23R

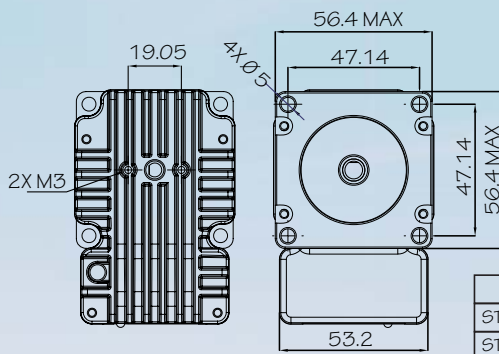

STM23S/Q/C/IP

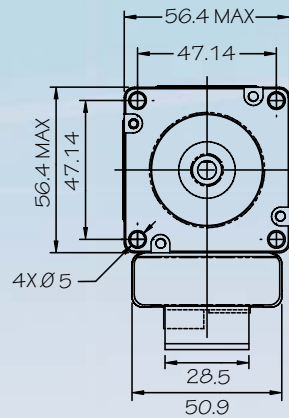

Model	Length "L"
STM23S/Q/C/IP-2	92.4
STM23S/Q/C/IP-3	114.4
STM23R-2	85
STM23R-3	107

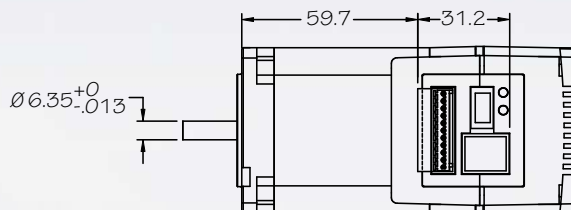
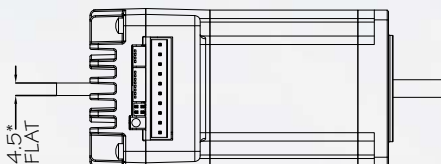
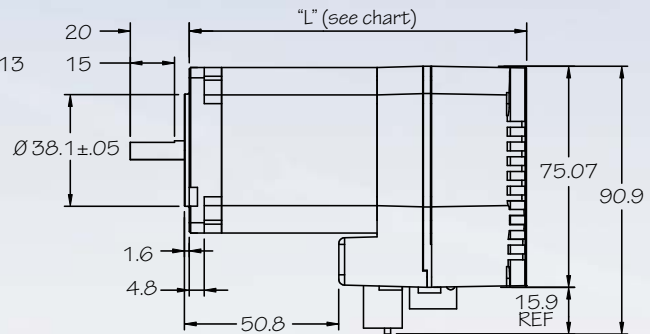
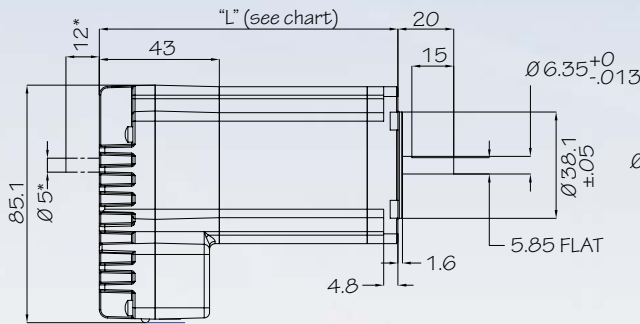

Dimensions in mm, not to scale
*rear shaft is only present on -ND and -NE versions

STM23-2 Torque Curves

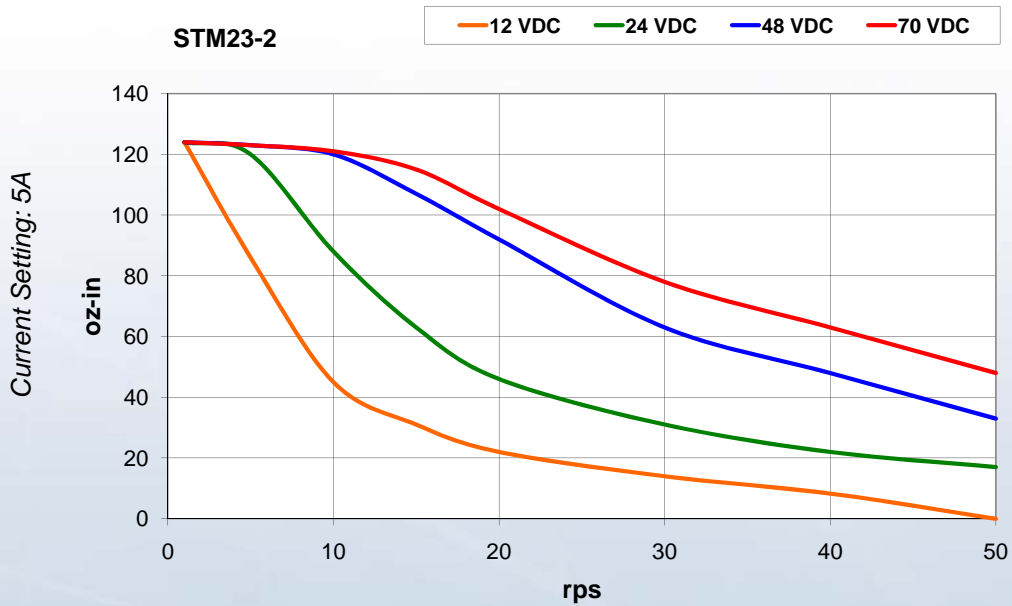

I/O Connections

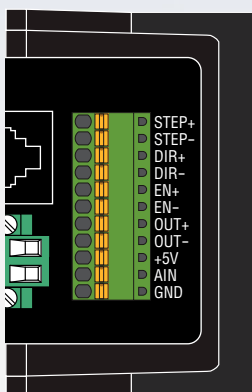

S

3 digital inputs
1 digital output
1 analog input

Q

3 digital inputs
1 digital output
1 analog input

IP

3 digital inputs
1 digital output
1 analog input

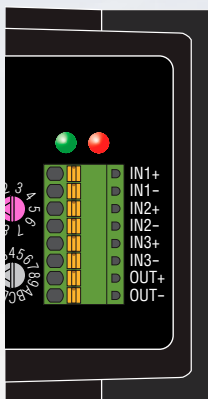

C

3 digital inputs
1 digital output

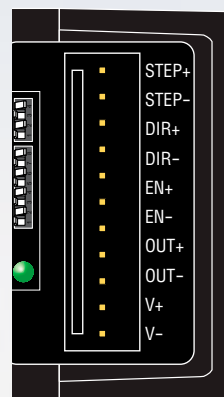

R

3 digital inputs
1 digital output

STM23 Technical Specifications

POWER AMPLIFIER:

AMPLIFIER TYPE	Dual H-bridge, 4 quadrant
CURRENT CONTROL	4 state PWM at 20 kHz
OUTPUT TORQUE	STM23-2: Up to 125 oz-in with suitable power supply STM23-3: Up to 210 oz-in with suitable power supply
POWER SUPPLY	External 12 - 70 VDC power supply required. Under-voltage alarm: 11 VDC. Over-voltage shutdown: 74 VDC
PROTECTION	Over-voltage, under-voltage, over-temp, motor/wiring shorts (phase-to-phase, phase-to-ground)
IDLE CURRENT REDUCTION	STM23S/Q/C/IP: Reduction range of 0 - 90% of running current after delay selectable in milliseconds. STM23R: Switch selectable 50% or 90% of running current.

CONTROLLER:

MICROSTEP RESOLUTION	STM23S/Q/C/IP: Software selectable from 200 to 51200 steps/rev in increments of 2 steps/rev. STM23R: Dip-switch selectable 200, 400, 800, 1000, 1600, 2000, 3200, 4000, 5000, 6400, 8000, 10000, 12800, 20000, 25000 or 25600 steps/rev.
MICROSTEP EMULATION	Performs high resolution stepping by synthesizing fine microsteps from coarse steps (step & direction mode only)
COMMAND SIGNAL SMOOTHING	Software configurable filtering reduces jerk and excitation of extraneous system resonances (step & direction mode)
ANTI-RESONANCE (Electronic Damping)	Raises the system damping ratio to eliminate midrange instability and allow stable operation throughout the speed range and improves settling time
AUTO SETUP	Measures motor parameters and configures motor current control and anti-resonance gain settings
SELF TEST	Checks internal & external power supply voltages, diagnoses open motor phases
NON-VOLATILE STORAGE	Configurations are saved in flash memory on-board the DSP
MODES OF OPERATION	STM23R: Step & direction or CW/CCW pulse (switch selectable) STM23S: Step & direction, CW/CCW pulse, A/B quadrature pulse, velocity (oscillator, joystick), streaming commands (SCL), SiNet Hub compatible STM23Q: All STM23S modes of operation plus stored Q program execution STM23C: CANopen slave node plus stored Q program execution STM23IP: All STM23Q modes of operation plus EtherNet/IP industrial network communications
DIGITAL INPUTS	<i>Adjustable bandwidth digital noise rejection filter on all inputs</i> STEP+/- (IN1+/-): Optically isolated, 5-24 volt. Minimum pulse width = 250 ns. Maximum pulse frequency = 3 MHz. Function: STM23R: Step, CW pulse; All others: Step, CW pulse, A quadrature (encoder following), CW limit, CW jog, start/stop (oscillator mode), or general purpose input. DIR+/- (IN2+/-): Optically isolated, 5-24 volt. Minimum pulse width = 250 ns. Maximum pulse frequency = 3 MHz. Function: STM23R: Direction, CCW pulse; All others: Direction, CCW pulse, B quadrature (encoder following), CCW limit, CCW jog, direction (oscillator mode), or general purpose input. EN+/- (IN3+/-): Optically isolated, 5-24 volt. Minimum pulse width = 250 ns. Maximum pulse frequency = 3 MHz. Function: STM23R: Enable; All others: Enable, alarm/fault reset, speed 1/speed 2 (oscillator mode).
DIGITAL OUTPUT	OUT+/-: Optically isolated, 30V/40 mA max. Function: STM23R: Fault; All others: Fault, motion, tach or general purpose programmable.
ANALOG INPUT	STM23S/Q/IP: AIN referenced to GND. Range = 0 to 5 VDC. Resolution = 12 bits. STM23R/C: No analog input
COMMUNICATION INTERFACE	STM23x-xAx: RS-232, STM23x-xEx: Ethernet, STM23x-xRx: RS-485, STM23C-3Cx: CANopen, RS-232, STM23IP-xEx: Ethernet, EtherNet/IP, STM23R-xNx: No communication port

APPROVALS:

AGENCY APPROVALS	RoHS, CE EN61800-3:2004
------------------	-------------------------

PHYSICAL:

OPERATING TEMPERATURE	0 to 85 °C (32 to 185 °F) Internal temperature of the electronics section and encoder 0 to 100 °C (32 to 212 °F) Temperature of motor body
AMBIENT TEMPERATURE	0 to 40 °C (32 to 104 °F) When mounted to a suitable heatsink
HUMIDITY	90% max, non-condensing
MASS	STM23-2: 30 oz (850 g), STM23-3: 42 oz (1191 g)
ROTOR INERTIA	STM23-2: 3.68×10^{-3} oz-in-sec ² (260 g-cm ²), STM23-3: 6.52×10^{-3} oz-in-sec ² (460 g-cm ²)

STM24 Torque Curves

STM24-3

Current Setting: 6A

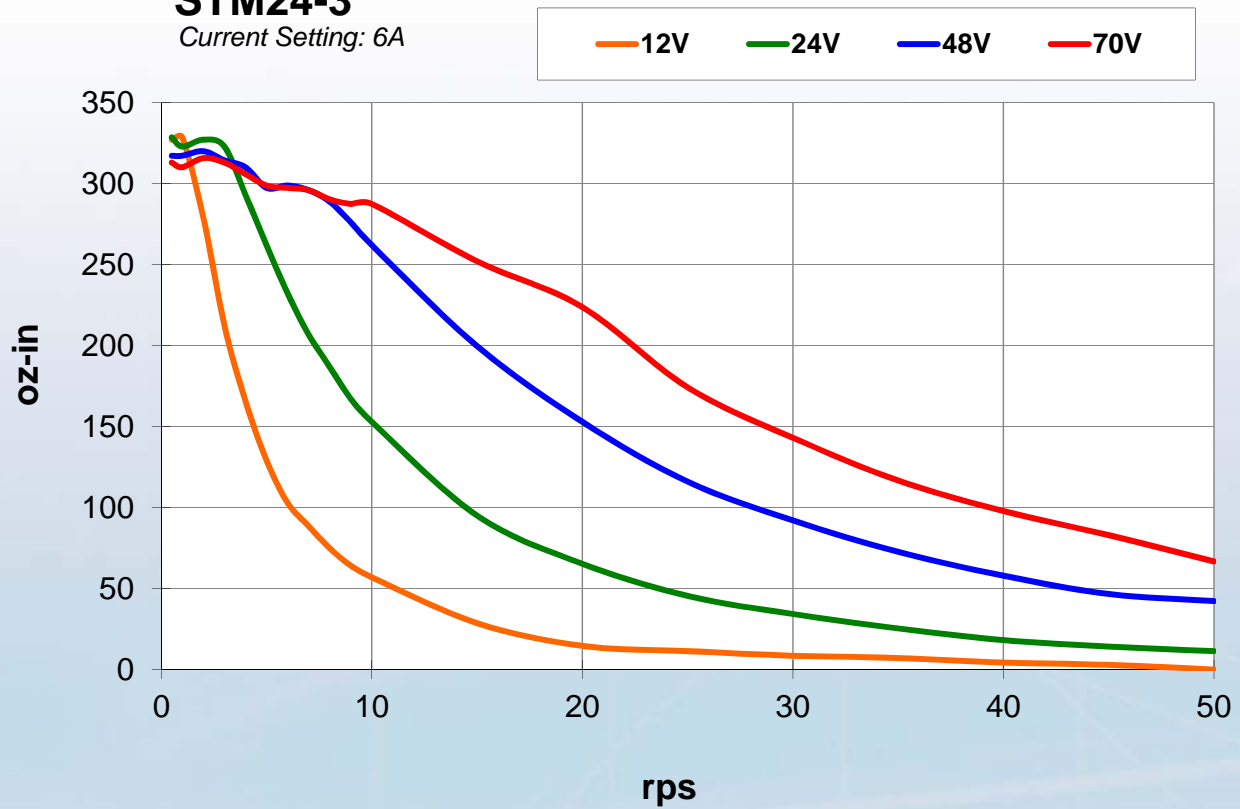

STM24 Technical Specifications

POWER AMPLIFIER:

AMPLIFIER TYPE	Dual H-bridge, 4 quadrant
CURRENT CONTROL	4 state PWM at 20 kHz
OUTPUT TORQUE	Up to 340 oz-in with suitable power supply
POWER SUPPLY	External 12 - 70 VDC power supply required Under-voltage alarm: 11 VDC Over-voltage shutdown: 74 VDC
PROTECTION	Over-voltage, under-voltage, over-temp, motor/wiring shorts (phase-to-phase, phase-to-ground)
IDLE CURRENT REDUCTION	Reduction range of 0 - 90% of running current after delay selectable in milliseconds

CONTROLLER:

MICROSTEP RESOLUTION	Software selectable from 200 to 51200 steps/rev in increments of 2 steps/rev
MICROSTEP EMULATION	Performs high resolution stepping by synthesizing fine microsteps from coarse steps (step & direction mode only)
COMMAND SIGNAL SMOOTHING	Software configurable filtering reduces jerk and excitation of extraneous system resonances (step & direction mode only)
ANTI-RESONANCE (Electronic Damping)	Raises the system damping ratio to eliminate midrange instability and allow stable operation throughout the speed range and improves settling time
AUTO SETUP	Measures motor parameters and configures motor current control and anti-resonance gain settings
SELF TEST	Checks internal & external power supply voltages, diagnoses open motor phases
NON-VOLATILE STORAGE	Configurations are saved in flash memory on-board the DSP
MODES OF OPERATION	STM24SF: Step & direction, CW/CCW pulse, A/B quadrature pulse, velocity (oscillator, joystick), streaming commands (SCL) STM24QF: All STM24S modes of operation plus stored Q program execution STM24C: CANopen slave node plus stored Q program execution
DIGITAL FLEX I/O <i>SF and QF models</i>	<i>Adjustable bandwidth digital noise rejection filter on all I/O points configured as inputs</i> When configured as Inputs: Optically isolated, 5-24 VDC, 8-12 mA. Minimum pulse width = 250 ns. Maximum pulse frequency = 3 MHz. Functions: see STM24 hardware manual. When configured as Outputs: Optically isolated, open emitter/collector, 30V/80mA max, 10 kHz max. Functions: see STM24 hardware manual.
DIGITAL I/O <i>C models</i>	<i>Adjustable bandwidth digital noise rejection filter on all inputs</i> IN1 - IN3: Optically isolated inputs, 5-24 VDC, 8-12 mA. Minimum pulse width = 250 ns. Maximum pulse frequency = 3 MHz. Functions: see STM24 hardware manual. OUT: Optically isolated output, open emitter/collector, 30V/80mA max. Function: see STM24 hardware manual.
ANALOG INPUT	AIN referenced to GND. Range = 0 to 5 VDC. Resolution = 12 bits. (Not present on STM24C).
COMMUNICATION INTERFACE	STM24x-3Ax: RS-232 STM24x-3Rx: RS-485 STM24C-3Cx: CANopen, RS-232

APPROVALS:

AGENCY APPROVALS	RoHS CE EN61800-3:2004
------------------	---------------------------

PHYSICAL:

OPERATING TEMPERATURE	0 to 85 °C (32 to 185 °F) Internal temperature of the electronics section and encoder 0 to 100 °C (32 to 212 °F) Temperature of motor body
AMBIENT TEMPERATURE	0 to 40 °C (32 to 104 °F) When mounted to a suitable heatsink
HUMIDITY	90% max, non-condensing
MASS	56 oz (1580 g)
ROTOR INERTIA	1.27 x 10 ⁻² oz-in-sec ² (900 g-cm ²)

Anti-Resonance/Electronic Damping

Step motor systems have a natural tendency to resonate at certain speeds. The STM drive+motor automatically calculates the system's natural frequency and applies damping to the control algorithm. This greatly improves midrange stability, allows for higher speeds, greater torque utilization and also improves settling times.

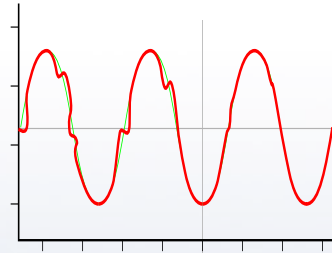

Delivers better motor performance and higher speeds

Microstep Emulation

With Microstep Emulation, low resolution systems can still provide smooth motion. The drive can take low-resolution step pulses and create fine resolution micro-step motion.

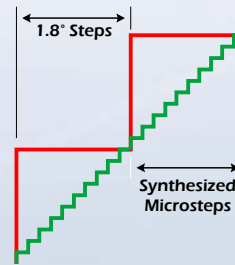

Delivers smoother motion in any application

Torque Ripple Smoothing

All step motors have an inherent low speed torque ripple that can affect the motion of the motor. By analyzing this torque ripple the system can apply a negative harmonic to negate this effect, which gives the motor much smoother motion at low speed.

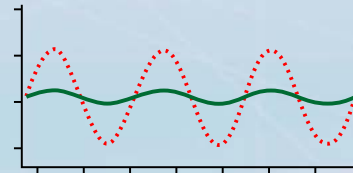

Delivers smoother motion at lower speeds

Command Signal Smoothing

Command Signal smoothing can soften the effect of immediate changes in velocity and direction, making the motion of the motor less jerky. An added advantage is that it can reduce the wear on mechanical components.

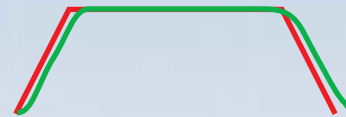

Delivers smoother system performance

Dynamic Current Control

Allows for three current settings to help the motor run cooler and reduce power consumption.

- Running Current - the current the drive will deliver for continuous motion.
- Accel Current - the current the drive will deliver when accelerating or decelerating.
- Idle Current - reduces current draw when motor is stationary.

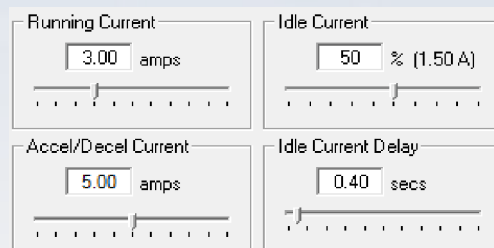

System runs cooler

Self Test & Auto Setup

At start-up the drive measures motor parameters, including the resistance and inductance, then uses this information to optimize the system performance.

Step & Direction

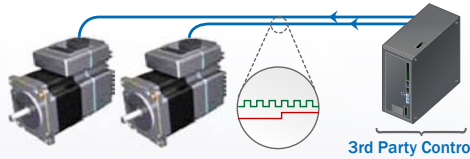

S R

- Step & direction
- CW & CCW pulse
- A/B quadrature (master encoder) (S only)

Oscillator / Run-Stop

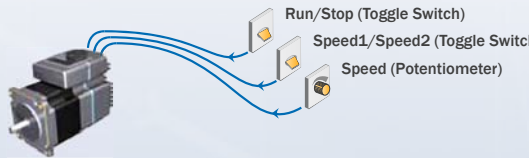

S

- Software configuration
- Two speeds
- Vary speed with analog input
- Joystick compatible

Host Control

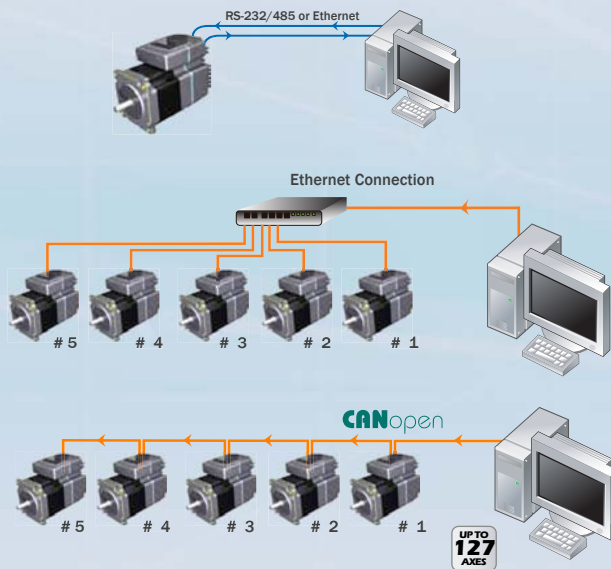

S Q

RS-232

- Accept serial commands from host PC or PLC

RS-485

- Accept serial commands from host PC or PLC
- Multi-axis capable, up to 32 axes

Q IP

- Accepts streaming commands from host PC or PLC
- 1000's of axes with Ethernet and EtherNet/IP

C

CANopen Model

- Connect to CANopen network
- DS301 and DSP402 protocols

Stand-Alone Programmable

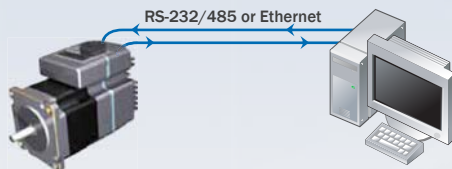

Q IP

- Comprehensive text based language
- Download, store & execute programs
- High level features: multi-tasking, conditional programming and math functions
- Host interface while executing stored programs

Multi-Axis Systems

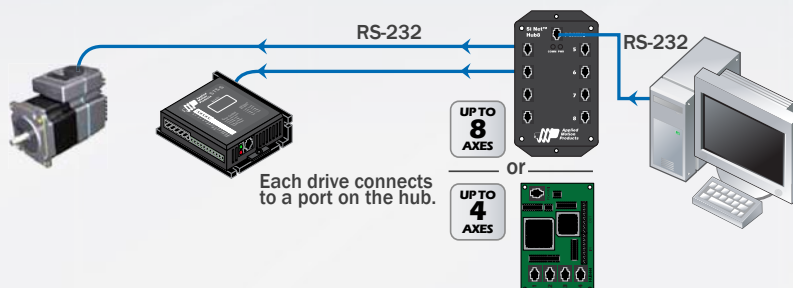

S Q

Use *SiNet Hub Programmer™* software to develop your sequence of events, then download them to a SiNet Hub for a stand-alone system (STM23 only) or stream serial commands to the drives from a PC, PLC, HMI, or other host controller.

Encoder Option, STM-S/Q/C/IP

The STM integrated steppers are offered with an optional 1000-line incremental encoder. On STM-S/Q/C/IP models this encoder is integrated into the housing of the motor, without increasing the overall size of the unit. The addition of this encoder provides the following enhanced functionality:

Stall Detection notifies the system as soon as the required torque is too great for the motor, resulting in a loss of synchronization between the rotor and stator, also known as stalling. As soon as the motor stalls the drive triggers its fault output. See diagram 1.

Stall Prevention automatically adjusts the excitation of the motor windings to maintain synchronization of the rotor and stator under all conditions. This means that motor position is maintained and corrected even when the required torque is too great for the motor. The stall prevention feature also performs position maintenance, which maintains the position of the motor shaft when at rest. See figure 2.

Diagram showing the position of the encoder inside the STM17

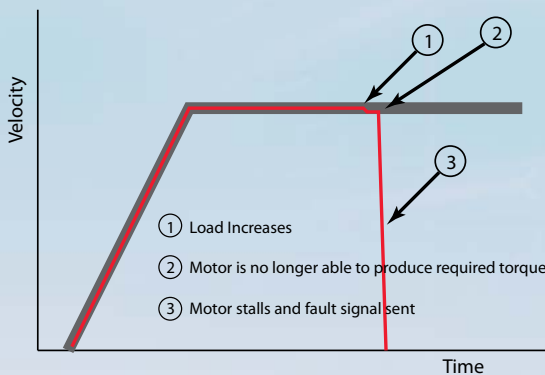
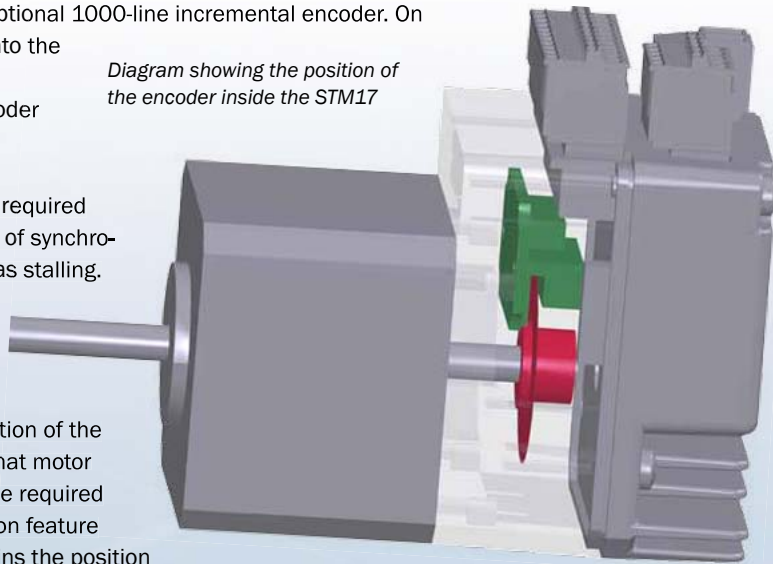

Figure 1: Diagram showing the Stall Detection process

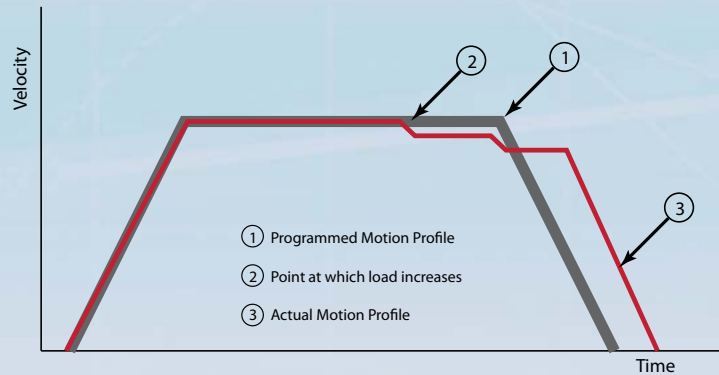

Figure 2: Diagram showing the Stall Prevention process

Encoder Option, STM-R

STM-R models can be ordered with an optional 1000-line incremental encoder mounted to the rear shaft of the unit. This encoder can be connected to the external controller for position verification and enhanced performance, depending on the features of the controller.



ST Configurator™

Used for setup and configuration of the STM drive+motor (all but R models). For more information about ST Configurator™ visit the Applied Motion Products website.

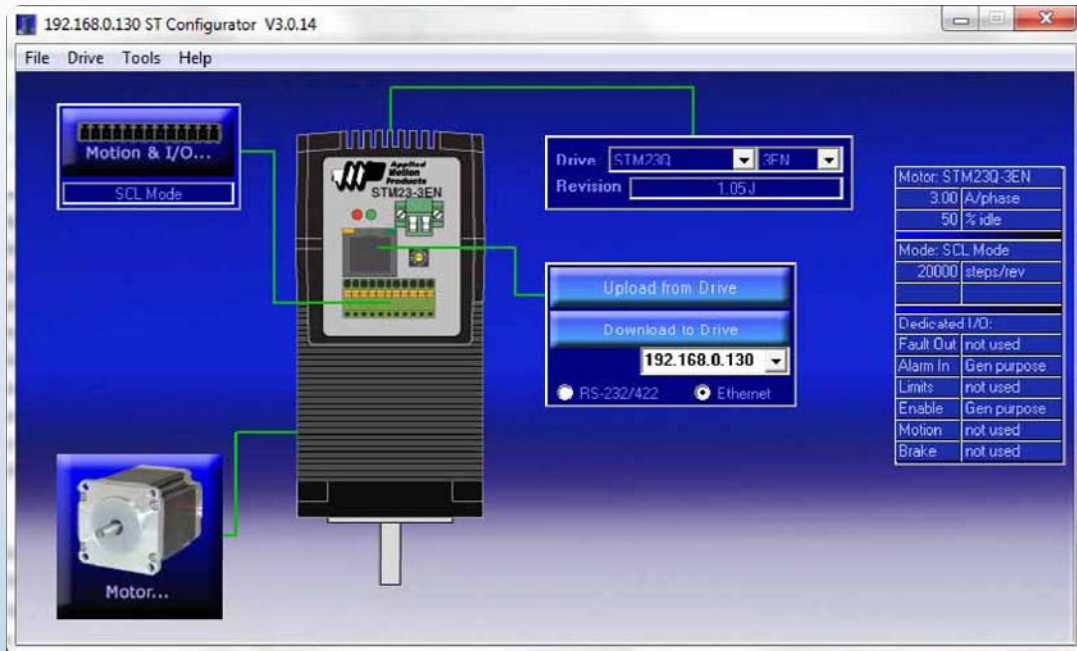

Q Programmer™

Q Programmer™ is used to create stored programs for Q, C and IP models. Q Programmer™ is a robust and powerful programming environment with functionality for multi-tasking, math, conditional processing, register manipulation, encoder following, analog positioning and more.

Stored Q programs can run stand-alone in Q and IP models, allowing the drive+motor to power up and begin operation on its own. Stored Q programs can be called from the host in C models using Applied Motion-specific CANopen objects.

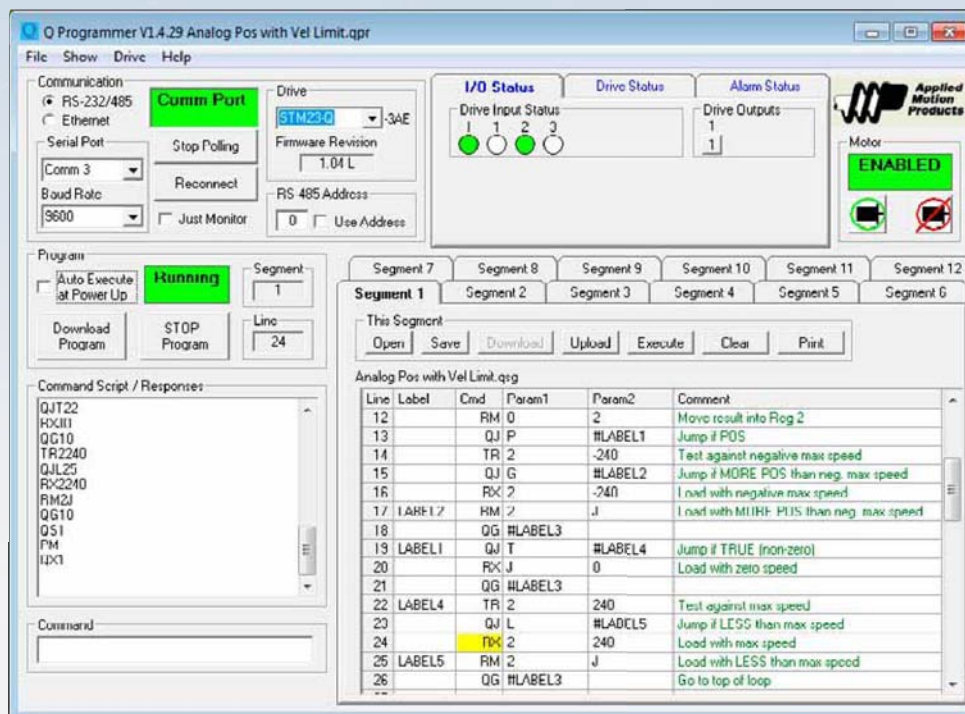

All software applications run on Windows 7 (32 & 64 bit), Vista, XP, 2000, NT, ME, 98.

Power Supplies

Applied Motion offers three matched power supplies for use with the STM drives.

- PS150A24 ... 24 VDC, 150 Watt for use with all STM drives.
- PS320A48 ... 48 VDC, 320 Watt for use with all STM drives.
- PS50A24 ... 24 VDC, 50 Watt for use with STM17 drives.

These power supplies have current overload capability making them ideal for use with stepper drives.



USB to RS-232/485 Adapter

For users without a serial port and/or wishing to take advantage of the benefits of an RS-485 network, Applied Motion offers an adapter (part number 8500-003) that will plug into a USB port and communicate to RS-232 and RS-485 networks.



RC-050 Regeneration Clamp

The RC-050 regeneration clamp is for use where regeneration from the motor may be excessive for the power supply. In these cases the RC-050 is connected between the drive and power supply and absorbs regenerated energy.



3004-189 Serial Programming Cable

The 3004-189 serial programming cable is included with all STM23 and STM24 products (all but R models) with the "A" communication option, and is used for setup and programming. This cable can also be used in streaming serial command (SCL) applications as a permanent connection between the drive and the host device's RS-232 port.



3004-259 Serial Programming Cable

The 3004-259 serial programming cable is included with all STM17 products (all but R models) with the "A" communication option, and is used for setup and programming. This cable can also be used in streaming serial command (SCL) applications as a permanent connection between the drive and the host device's RS-232 port.



STM23S-2AN

Series
STM Stepper Drive+Motor

NEMA Frame Size
17
23
24

Control Option

R = Step & Direction only
S = Velocity & Streaming Commands
SF = Velocity & Streaming Commands w/ Flex I/O
Q = Q Programmer
QF = Q Programmer w/ Flex I/O
C = CANopen
IP = EtherNet/IP

Feedback/Rear Shaft

D = Rear shaft w/o encoder
E = 1000 line encoder
N = No encoder/No rear shaft

Communications

A = RS-232 C = CANopen (requires C control option)
E = Ethernet N = None
R = RS-485

Motor Length (inch)

	17R	17S/Q/C	23R	23S/Q/C/IP	24SF/QF/C
2	n/a	n/a	3.35	3.64	n/a
3	2.64	3.19	4.21	4.50	4.94

PART NUMBERS	PULSE & DIRECTION	STREAMING COMMANDS	Q PROGRAMMING	RS-232	RS-422/485	CANOPEN	ETHERNET	ETHERNET/IP	REAR SHAFT	ENCODER
STM17Q-3AE	X	X	X	X						X
STM17Q-3AN	X	X	X	X						
STM17Q-3RE	X	X	X		X					X
STM17Q-3RN	X	X	X		X					
STM17S-3AE	X	X		X						X
STM17S-3AN	X	X		X						
STM17S-3RE	X	X			X					X
STM17S-3RN	X	X			X					
STM17R-3ND	X								X	
STM17R-3NE	X								X	X
STM17R-3NN	X									
STM17C-3CE				X		X				X
STM17C-3CN				X		X				
STM23Q-2AE	X	X	X	X						X
STM23Q-2AN	X	X	X	X						
STM23Q-2EE	X	X	X				X			X
STM23Q-2EN	X	X	X				X			
STM23Q-2RE	X	X	X		X					X
STM23Q-2RN	X	X	X		X					
STM23Q-3AE	X	X	X	X						X
STM23Q-3AN	X	X	X	X						
STM23Q-3EE	X	X	X				X			X
STM23Q-3EN	X	X	X				X			
STM23Q-3RE	X	X	X		X					X
STM23Q-3RN	X	X	X		X					
STM23IP-2EE		X	X				X	X		X
STM23IP-2EN		X	X				X	X		
STM23IP-3EE		X	X				X	X		X
STM23IP-3EN		X	X				X	X		

PART NUMBERS	PULSE & DIRECTION	STREAMING COMMANDS	Q PROGRAMMING	RS-232	RS-422/485	CANOPEN	ETHERNET	ETHERNET/IP	REAR SHAFT	ENCODER
STM23S-2AE	X	X		X						X
STM23S-2AN	X	X		X						
STM23S-2EE	X	X					X			X
STM23S-2EN	X	X					X			
STM23S-2RE	X	X			X					X
STM23S-2RN	X	X			X					
STM23S-3AE	X	X		X						X
STM23S-3AN	X	X		X						
STM23S-3EE	X	X					X			X
STM23S-3EN	X	X					X			
STM23S-3RE	X	X			X					X
STM23S-3RN	X	X			X					
STM23R-2ND	X								X	
STM23R-2NE	X								X	X
STM23R-2NN	X									
STM23R-3ND	X								X	
STM23R-3NE	X								X	X
STM23R-3NN	X									
STM23C-3CE				X		X				X
STM23C-3CN				X		X				
STM24QF-3AE	X	X	X	X						X
STM24QF-3AN	X	X	X	X						
STM24QF-3RE	X	X	X		X					X
STM24QF-3RN	X	X	X		X					
STM24SF-3AE	X	X		X						X
STM24SF-3AN	X	X		X						
STM24SF-3RE	X	X			X					X
STM24SF-3RN	X	X			X					
STM24C-3CE				X		X				X
STM24C-3CN				X		X				



Applied Motion Products

404 Westridge Dr.
Watsonville, CA 95076
Tel: 800-525-1609
Fax: 831-761-6544
www.applied-motion.com

DISTRIBUTED BY:

Mouser Electronics

Authorized Distributor

Click to View Pricing, Inventory, Delivery & Lifecycle Information:

Applied Motion:

[STM23S-2AE](#) [STM23S-2RN](#) [STM23S-2RE](#) [STM23Q-2AE](#) [STM23Q-2RN](#) [STM23Q-2RE](#) [STM23S-3AE](#) [STM23S-3RN](#) [STM23S-3RE](#) [STM23Q-3AE](#) [STM23Q-3RN](#) [STM23Q-3RE](#) [STM23C-3CN](#) [STM23C-3CE](#) [STM24C-3CN](#) [STM24C-3CE](#) [STM17R-3NN](#) [STM17R-3ND](#) [STM17R-3NE](#) [STM17S-3AN](#) [STM17S-3RN](#) [STM17Q-3AN](#) [STM17Q-3AE](#) [STM17Q-3RN](#) [STM17Q-3RE](#) [STM17C-3CN](#) [STM17C-3CE](#) [STM23R-2NN](#) [STM23R-2ND](#) [STM23R-2NE](#) [STM23R-3NN](#) [STM23R-3ND](#) [STM23R-3NE](#) [STM24SF-3AN](#) [STM24SF-3AE](#) [STM24SF-3RN](#) [STM24SF-3RE](#) [STM24QF-3AN](#) [STM24QF-3AE](#) [STM24QF-3RN](#) [STM24QF-3RE](#) [STM23S-3AE-000](#) [STM23S-3AN](#) [STM24IP-3EN](#) [STM23IP-2EE](#) [STM23Q-3EE](#) [STM23IP-3EN](#) [STM23Q-3AN](#) [STM24S-3EN](#) [STM23S-2EE](#) [STM23Q-3EN](#) [STM23S-2AN](#) [STM23S-3EE](#) [STM23S-2EN](#) [STM23Q-2EE](#) [STM23Q-2EN](#) [STM24IP-3EE](#) [STM23IP-3EE](#) [STM23Q-2AN](#) [STM24S-3EE](#) [STM24Q-3EE](#) [STM24Q-3EN](#) [STM23S-3EN](#)