

REACH & RoHS
COMPLIANT

REV.	ECN / DESCRIPTION	BY	DATE
A0	NEW	X.YAN	2017.11.8

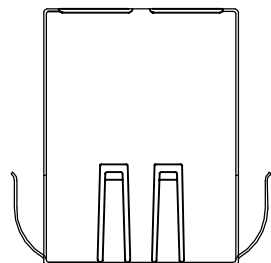

TOP VIEW

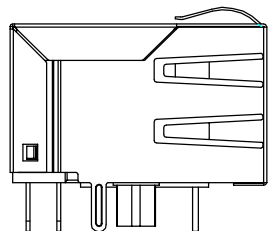

LEFT SIDE VIEW

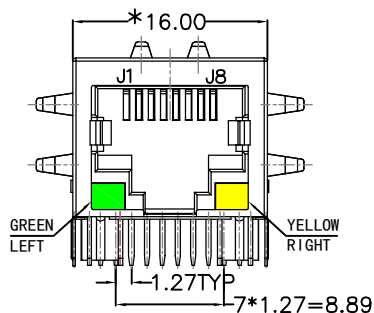

FRONT VIEW

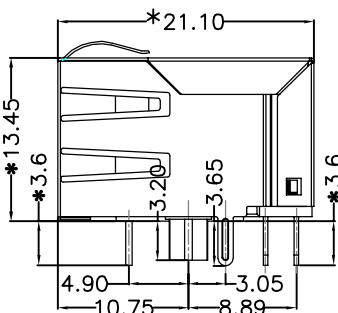

RIGHT SIDE VIEW

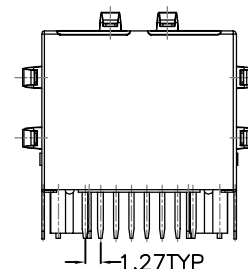

BACK VIEW

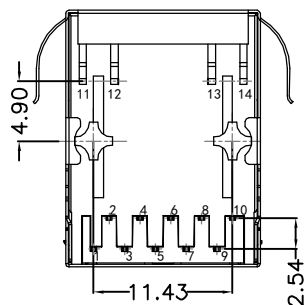

BOTTOM VIEW

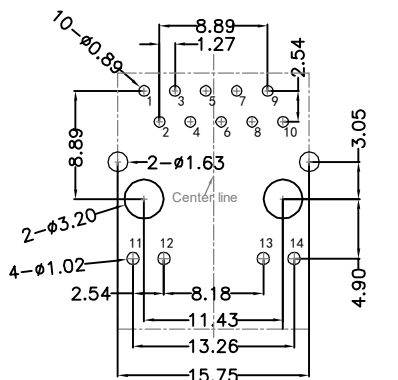

RECOMMENDED PCB LAYOUT
VIEWED FROM COMPONENT SIDE

MATERIAL:

HOUSING : PBT,UL94V-0,BLACK.
 TERMINALS BRACKET: PBT,UL94V-0,BLACK.
 SHIELD: C2680,T=0.20MM,NICKEL PLATING ON ALL AREA.
 TERMINAL: PHOSPHOR BRONZE C5210,T=0.35MM,
 6U" GOLD PLATING ON CONTACT AREA.

MECHANICAL:

DURABILITY : 750 CYCLES MIN.
 MATING FORCE : 23N MAX.
 OPERATING TEMPERATURE: -40°C~+85°C.
 STORAGE TEMPERATURE: -40°C~+85°C.
 ALL CRITICAL DIMENSIONS WITH "*"

CND-tek
磁联达

深圳磁联达电子有限公司
Shenzhen magnetic Lianda Electronics Co., LTD

Address: 505, West Block, No. 221, Niucheng Road, Niucheng Village, Baiwang
Community, Xili Street, Nanshan District, Shenzhen
E-mail: sales1@cd-tek.com 0755-27652992 29016433 Website:www.cd-tek.com

TITLE:
TAB-DOWN 1X1 10/100/1000BASE

PART NO.:
TE611130GH

REMARK:

SIZE
A4

SACLE
1:1

SHEET
1/4

UNITS
MM[INCH]

REV
A0

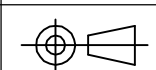

GENERAL TOLERANCES
UNLESS SPECIFIED

x±0.35	x°±3.0°
.x±0.30	.x°±2.0°
.xx±0.25	.xx°±1.5°
.xxx±0.10	.xxx°±1.0°

APPROVED BY:
QG.CHEN

CHECKED BY:
SL.WANG

DESIGND BY:
X.YAN

REACH & RoHS
COMPLIANT

REV.	ECN / DESCRIPTION	BY	DATE
A0	NEW	X.YAN	2017.11.8

RECOMMENDED PANEL CUTOUT (REFERENCE ONLY):

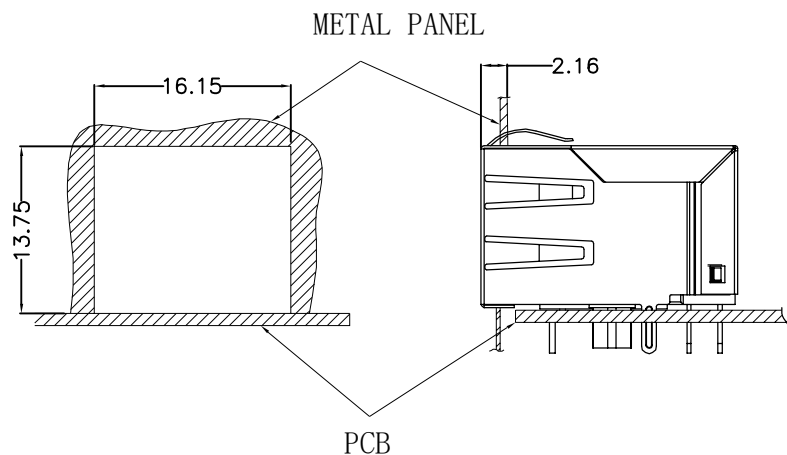

UNIT: MM / INCH
TOLERANCES: ± 0.10 / 0.004
REFERENCE ONLY

KEEP-OUT AREA (COMPONENT SIDE VIEW):

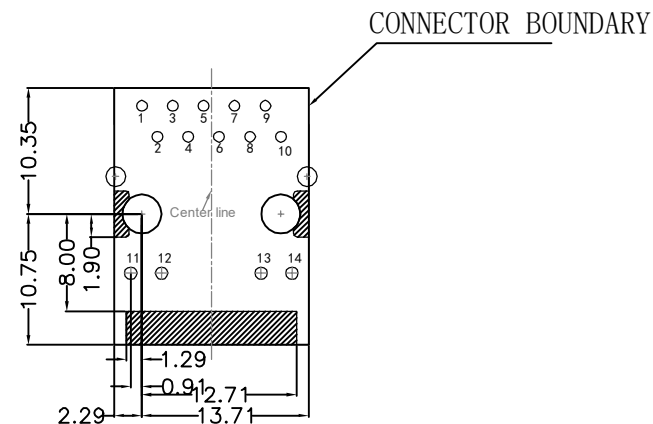

PLUG-IN SIDE

UNIT: MM / INCH
TOLERANCES: ± 0.10 / 0.004

CND-tek
磁联达

深圳磁联达电子有限公司
Shenzhen magnetic Lianda Electronics Co., LTD

Address: 505, West Block, No. 221, Niucheng Road, Niucheng Village, Baiwang
Community, Xili Street, Nanshan District, Shenzhen
E-mail: sales1@cd-tek.com 0755-27652992 29016433 Website: www.cd-tek.com

TITLE:
TAB-DOWN 1X1 10/100/1000BASE

PART NO.:
TE611130GH

REMARK:

SIZE
A4

SACLE
1:1

SHEET
2/4

UNITS
MM[INCH]

REV
A0

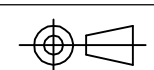

GENERAL TOLERANCES
UNLESS SPECIFIED

$x \pm 0.35$
 $x \pm 0.30$
 $.xx \pm 0.25$
 $.xxx \pm 0.10$

$x^\circ \pm 3.0^\circ$
 $.x^\circ \pm 2.0^\circ$
 $.xx^\circ \pm 1.5^\circ$
 $.xxx^\circ \pm 1.0^\circ$

APPROVED BY:
QG.CHEN

CHECKED BY:
SL.WANG

DESIGN BY:
X.YAN

REACH & RoHS
COMPLIANT

REV.	ECN / DESCRIPTION	BY	DATE
A0	NEW	X.YAN	2017.11.8

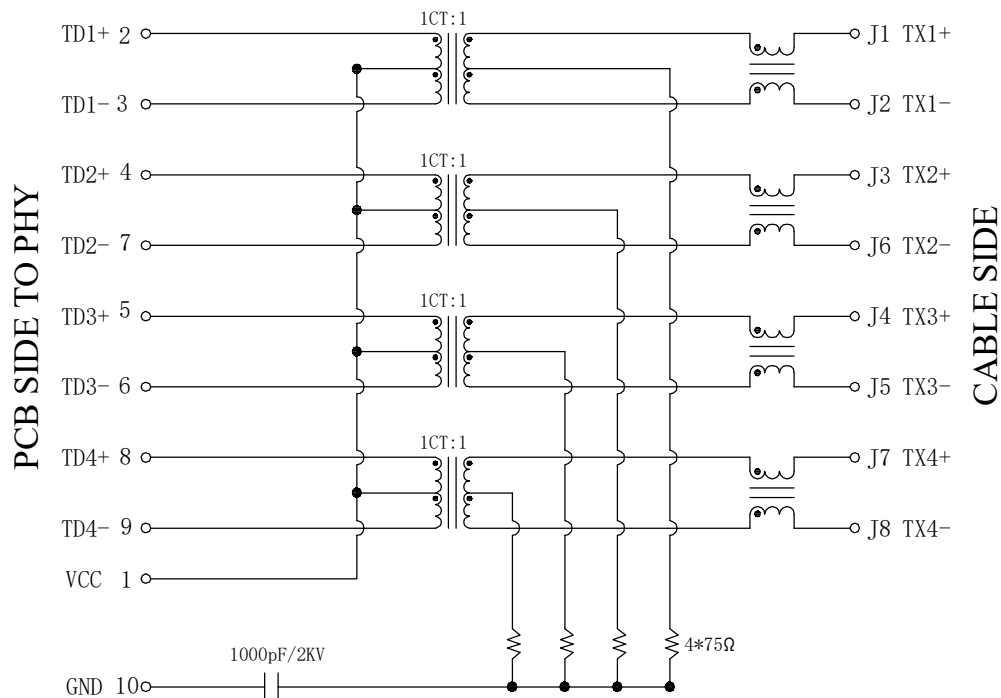

Electrical:

- Turn ratio: 2~3: J1~J2=1CT:1CT(±2%).
4~7: J3~J6=1CT:1CT(±2%).
5~6: J4~J5=1CT:1CT(±2%).
8~9: J7~J8=1CT:1CT(±2%).
- OCL: 350uH Min. at 100KHz 100mV 8mA DC.
- Insertion Loss: -1.0 dB Max 1~100MHz.
- Return loss: -18dB Min 1~30MHz;
-14dB Min 30~60MHz.
-12dB Min 60~80MHz.
-10dB Min 80~100MHz.
- Cross talk: -40dB Min 1~30MHz;
-35dB Min 30~60MHz;
-30dB Min 60~100MHz;
- CMR: -30dB Min 1~100MHz;
- Hi-Pot: 2250V DC 6S 1mA PRI TO SEC

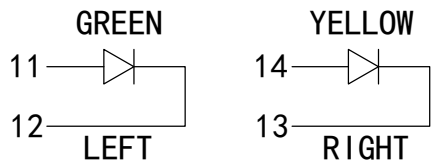

LED Specification

Standard LED Color	LED Wavelength	Foward(A)	Foward(V)
Green	568nm	20mA	1.85-2.45V
Yellow	585nm	20mA	1.7-2.2V

CND-tek
磁联达

深圳磁联达电子有限公司
Shenzhen magnetic Lianda Electronics Co., LTD

Address: 505, West Block, No. 221, Niucheng Road, Niucheng Village, Baiwang Community, Xili Street, Nanshan District, Shenzhen
E-mail: sales1@cd-tek.com 0755-27652992 29016433 Website: www.cd-tek.com

TITLE: TAB-DOWN 1X1 10/100/1000BASE	SIZE A4	UNITS MM[INCH]	GENERAL TOLERANCES UNLESS SPECIFIED		APPROVED BY: QG.CHEN
PART NO.: TE611130GH	SACLE 1:1	REV A0	x±0.35 .x±0.30	x°±3.0° .x°±2.0°	CHECKED BY: SL.WANG
REMARK:	SHEET 3/4		.xx±0.25 .xxx±0.10	.xx°±1.5° .xxx°±1.0°	DESIGND BY: X.YAN

REACH & RoHS
COMPLIANT

PROFILE OF WAVE SOLDER

REV.	ECN / DESCRIPTION	BY	DATE
A0	NEW	X.YAN	2017.11.8

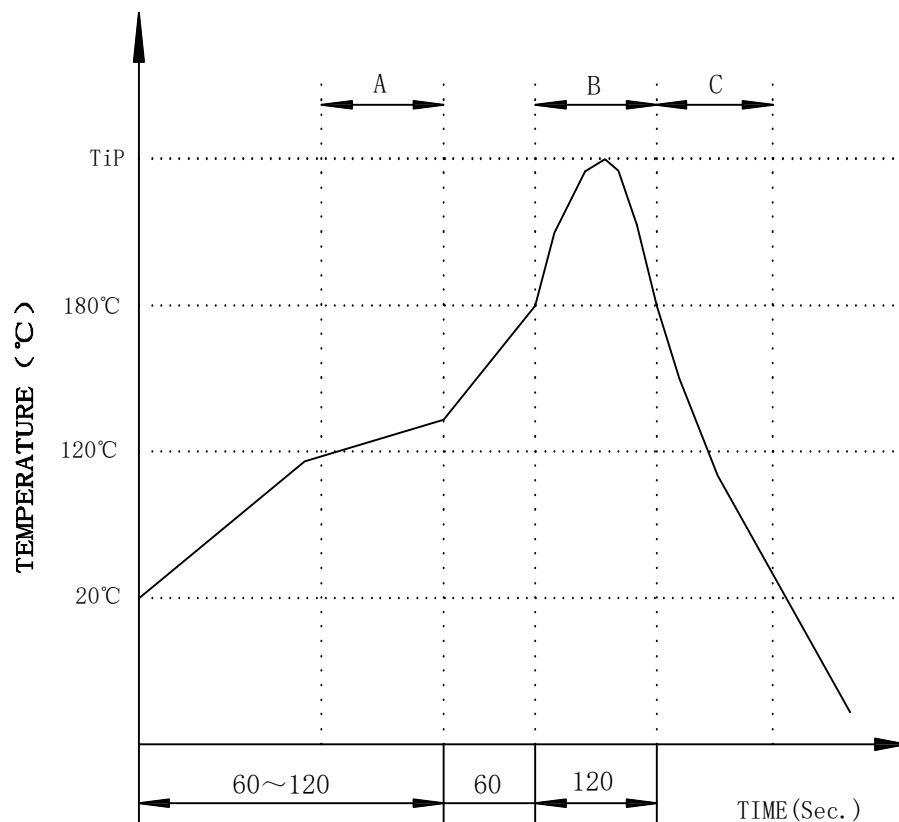

A.Preheating B.Soldering C.Gradual Cooling
 Tip temperature:260±5°C.
 Tip temperature time:5Sec Max.
 Tip melting point of Sn96.5/Ag3/Cu0.5:217°C.

Remarks: after wave soldering, the plastic positioning columns of the product which under the PCB will be slightly melted, but it won't affect its function.

CND-tek
磁联达

深圳磁联达电子有限公司
Shenzhen magnetic Lianda Electronics Co., LTD

Address: 505, West Block, No. 221, Niucheng Road, Niucheng Village, Baiwang Community, Xili Street, Nanshan District, Shenzhen
E-mail: sales1@cd-tek.com 0755-27652992 29016433 Website:www.cd-tek.com

TITLE:
TAB-DOWN 1X1 10/100/1000BASE

PART NO.:
TE611130GH

REMARK:

SIZE
A4

SACLE
1:1

SHEET
4/4

UNITS
MM[INCH]

REV
A0

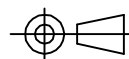

GENERAL TOLERANCES
UNLESS SPECIFIED

x±0.35

.x±0.30

.xx±0.25

.xxx±0.10

x°±3.0°

.x°±2.0°

.xx°±1.5°

.xxx°±1.0°

APPROVED BY:
QG.CHEN

CHECKED BY:
SL.WANG

DESIGND BY:
X.YAN