



1.0MHz,24V/2.0A High Performance, Boost Converter

General Description

The LP6230C is a 1MHz PWM boost switching regulator designed for constant-voltage boost applications. The LP6230C can drive a string of up to 30V. The LP6230C implements a constant frequency 1MHz PWM control scheme. The high frequency PWM operation also saves board space by reducing external component sizes. The LP6230C features automatic shifting to pulse frequency modulation mode at light loads. Highly integration and internal compensation network minimizes as 6 external component counts. Optimized operation frequency can meet the requirement of small LC filters value and low operation current with high efficiency. The LP6230C includes under-voltage lockout, current limiting, and thermal overload protection to prevent damage in the event of an output overload. The LP6230A is available in a small 8-pin MSOP8 package.

Order Information

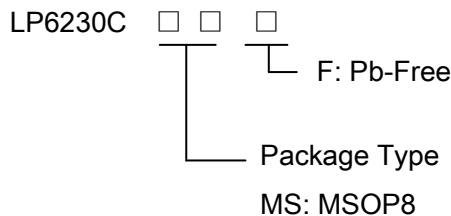

Applications

- ✧ Panel Bias Voltage supply
- ✧ OLED Backlight driver
- ✧ Portable Applications
- ✧ MID/PTV

Features

- ◆ High Efficiency: 90%
- ◆ 1MHz Fixed-Frequency PWM Operation
- ◆ Maximum Output Voltage up to 24V
- ◆ Guaranteed 13V/200mA Output with 5V input
- ◆ Operating Range : 2.2V to 6V
- ◆ Shutdown Supply Current:<1uA
- ◆ Minimize the External Component
- ◆ RoHS Compliant and 100% Lead(Pb)-Free
- ◆ Available in MSOP8 Package

Typical Application Circuit

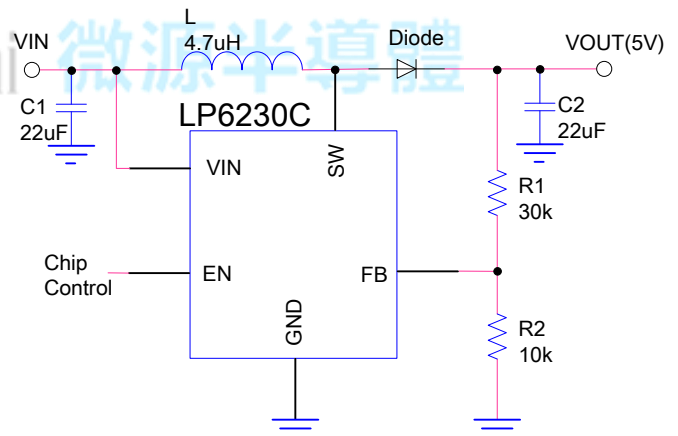

Marking Information

Device	Marking	Package	Shipping
LP6230C		MSOP8	3K/REEL



Functional Pin Description

Package Type		Pin Configurations
MSOP8		
Pin	Name	Description
1,7,8	NC	No Connector.
2	FB	Regulation Feedback Input. Connect to an external resistive voltage divider from the output to FB to set the output voltage.
3	EN	Regulator ON/OFF Control Input. A logic high input($V_{EN} > 1.4V$) turns on the regulator. A logic low input($V_{EN} < 0.4V$) puts the LP6230C into low current shutdown mode.
4	GND	Ground.
5	SW	Switching pin.
6	VIN	Power Supply pin.

Function Diagram

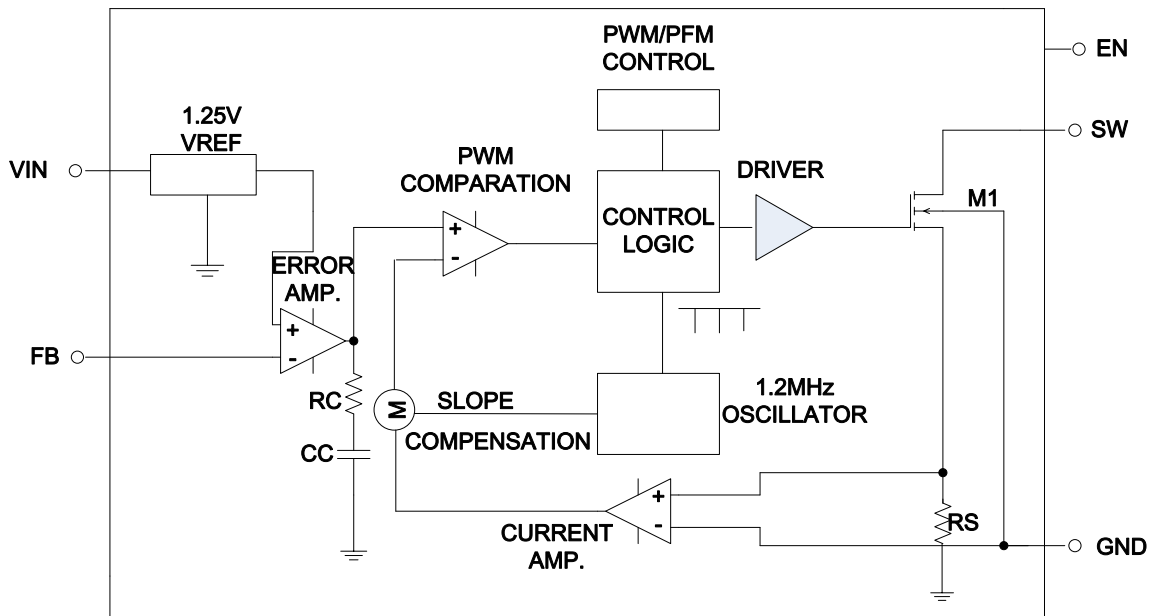



Absolute Maximum Ratings ^{Note 1}

- ◇ VIN to GND ----- -0.3V to 6.5V
- ◇ SW to GND ----- -0.3V to 30V
- ◇ Other Pin to GND ----- -0.3V to 6V
- ◇ Maximum Junction Temperature ----- 150°C
- ◇ Operating Ambient Temperature Range ----- -20°C to 85°C
- ◇ Maximum Soldering Temperature (at leads, 10 sec) ----- 260°C

Note 1. Stresses beyond those listed under “Absolute Maximum Ratings” may cause permanent damage to the device. These are stress ratings only, and functional operation of the device at these or any other conditions beyond those indicated in the operational sections of the specifications is not implied. Exposure to absolute maximum rating conditions for extended periods may affect device reliability.

Thermal Information

- ◇ Maximum Power Dissipation (MSOP8,PD,TA=25°C) ----- 900mW
- ◇ Thermal Resistance (θ_{JA}) ----- 165°C/W

ESD Susceptibility

- ◇ HBM(Human Body Mode) ----- 2KV
- ◇ MM(Machine Mode) ----- 200V

Electrical Characteristics

(VIN=3.5V, VOUT=5V, CIN=10uF, COUT=22uF, L1=4.7uH, R1=30K, R2=10K)

Parameter	Symbol	Condition	Min	Typ	Max	Units
Operation voltage Range	VIN		2.2		6	V
Input Under Voltage Lockout	UVLO			2.0		V
UVLO Hysteresis Voltage				0.2		V
Supply Current	IQ	VFB=1.3V		100		μA
Shut Down Current	ISD	VEN=0V		0.1	1	μA
Operation Frequency	fOSC			1.0		MHz
Maximum Duty Cycle			93			%
Feedback Voltage	VFB		1.22	1.25	1.28	V
On Resistance of MOSFET	RDS(ON)			0.3		Ω
SW Current Limit	ILM			2		A
Shut Down Voltage	VEN(OFF)				0.4	V
Enable on Voltage	VEN(ON)		1.4			V



Typical Operating Characteristics

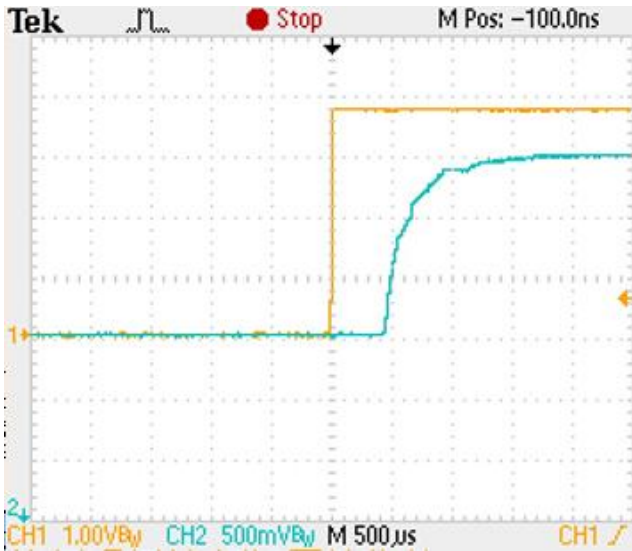

Start up Waveform CH₁=V_{EN}, CH₂=V_{OUT}

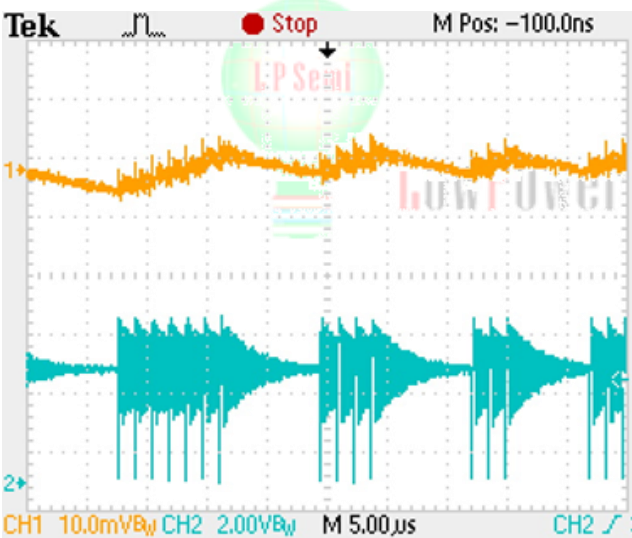
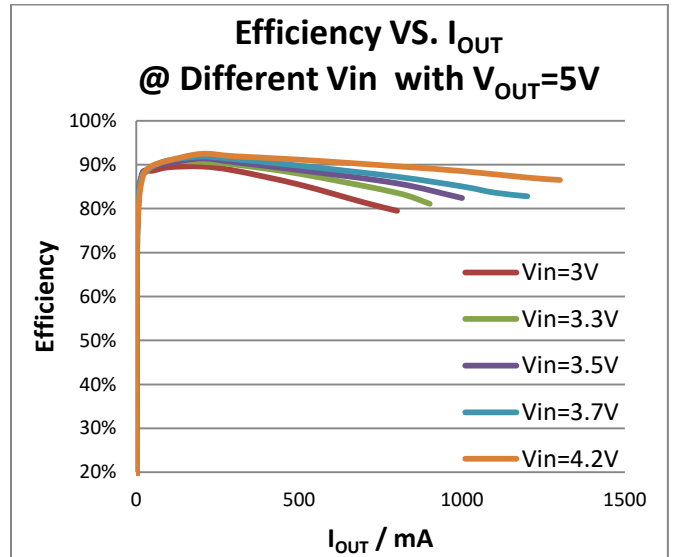

CH₁=ΔV_{OUT}, CH₂=V_{SW} @ V_{IN}=3.7V, V_{OUT}=5V, I_{OUT}=1mA

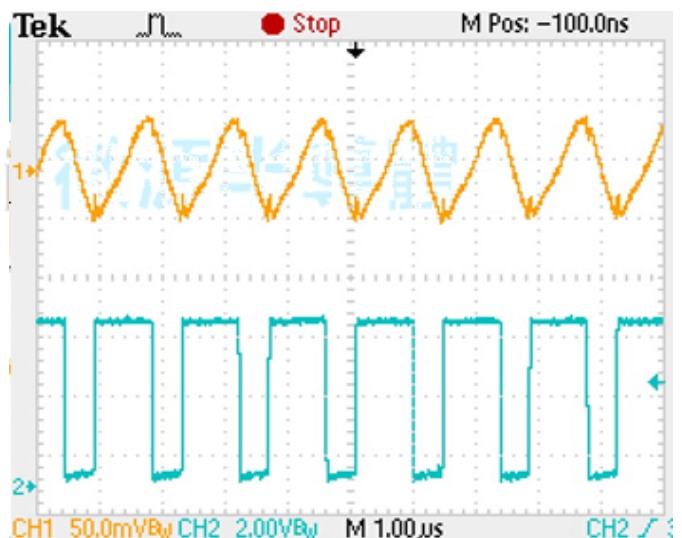

CH₁=ΔV_{OUT}, CH₂=V_{SW} @ V_{IN}=3.7V, V_{OUT}=5V, I_{OUT}=500mA



Operation Information

The LP6230C uses a fixed frequency, peak current mode boost regulator architecture to regulate voltage at the feedback pin. At the start of each oscillator cycle the MOSFET is turned on through the control circuitry. To prevent sub-harmonic oscillations at duty cycles greater than 50 percent, a stabilizing ramp is added to the output of the current sense amplifier and the result is fed into the negative input of the PWM comparator. When this voltage equals the output voltage of the error amplifier the power MOSFET is turned off. The voltage at the output of the error amplifier is an amplified version of the difference between the 1.25V bandgap reference voltage and the feedback voltage. In this way the peak current level keeps the output in regulation. If the feedback voltage starts to drop, the output of the error amplifier increases. These results in more current to flow through the power MOSFET, thus increasing the power delivered to the output. The LP6230C has internal soft start to limit the amount of input current at startup and to also limit the amount of overshoot on the output.

Setting the Output Voltage

Set the output voltage by selecting the resistive voltage divider ratio. The voltage divider drops the output voltage to the 1.25V feedback voltage. Use a 100K resistor for R₂ of the voltage divider. Determine the high-side resistor R₁ by the equation:

$$V_{OUT} = (R_1 / R_2 + 1) \times V_{FB}$$

Current Limitation

The internal power-MOS switch current is monitored cycle-by-cycle and is limited to the value not exceed 2.0A(Typ.). When the switch current reaches the limited value, the internal power-MOS is turned off immediately until the next cycle.

Inductor Selection

For a better efficiency in high switching frequency converter, the inductor selection has to use a proper core material such as ferrite core to reduce the core loss and choose low ESR wire to reduce copper loss. The most important point is to prevent the core saturated when handling the maximum peak current. Using a shielded inductor can minimize radiated noise in sensitive applications. The maximum peak inductor current is the maximum input current plus the half of inductor ripple current. The calculated peak current has to be smaller than the current limitation in the electrical characteristics. A typical setting of the inductor ripple current is 20% to 40% of the maximum input current. If the selection is 40%, the maximum peak inductor current is

$$I_{PEAK} = I_{IN(MAX)} + \frac{1}{2} I_{RIPPLE} = 1.2 \times I_{IN(MAX)} \\ = 1.2 \times \left[\frac{I_{OUT(MAX)} \times V_{OUT}}{\eta \times V_{IN(MIN)}} \right]$$

The minimum inductance value is derived from the following equation:

$$L = \frac{\eta \times V_{IN(MIN)}^2 \times [V_{OUT} - V_{IN(MIN)}]}{0.4 \times I_{OUT(MAX)} \times V_{OUT}^2 \times f_{OSC}}$$

Depending on the application, the recommended inductor value is between 2.2μH to 10μH.



Diode Selection

To achieve high efficiency, Schottky diode is good choice for low forward drop voltage and fast switching time. The output diode rating should be able to handle the maximum output voltage, average power dissipation and the pulsating diode peak current.

Input Capacitor Selection

For better input bypassing, low-ESR ceramic capacitors are recommended for performance. A 10 μ F input capacitor is sufficient for most applications. For a lower output power requirement application, this value can be decreased.

Output Capacitor Selection

For lower output voltage ripple, low-ESR ceramic capacitors are recommended. The tantalum capacitors can be used as well, but the ESR is bigger than ceramic capacitor. The output voltage ripple consists of two components: one is the pulsating output ripple current flows through the ESR, and the other is the capacitive ripple caused by charging and discharging.

$$\begin{aligned} V_{\text{RIPPLE}} &= V_{\text{RIPPLE_ESR}} + V_{\text{RIPPLE_C}} \\ &\cong I_{\text{PEAK}} \times R_{\text{ESR}} + \frac{I_{\text{PEAK}}}{C_{\text{OUT}}} \left(\frac{V_{\text{OUT}} - V_{\text{IN}}}{V_{\text{OUT}} \times f_{\text{OSC}}} \right) \end{aligned}$$

Layout Guideline

For high frequency switching power supplies, the PCB layout is important step in system application design. In order to let IC achieve good regulation, high efficiency and stability, it is strongly recommended the power components should be placed as close as possible. The set traces should be wide and short. The feedback pin and then works of feedback and compensation should keep away from the power loops, and be shielded with a ground trace or plane to prevent noise coupling. Input and Output capacitors should be placed close to the IC and connected to ground plane to reduce noise coupling.



Packaging Information

MSOP-8L

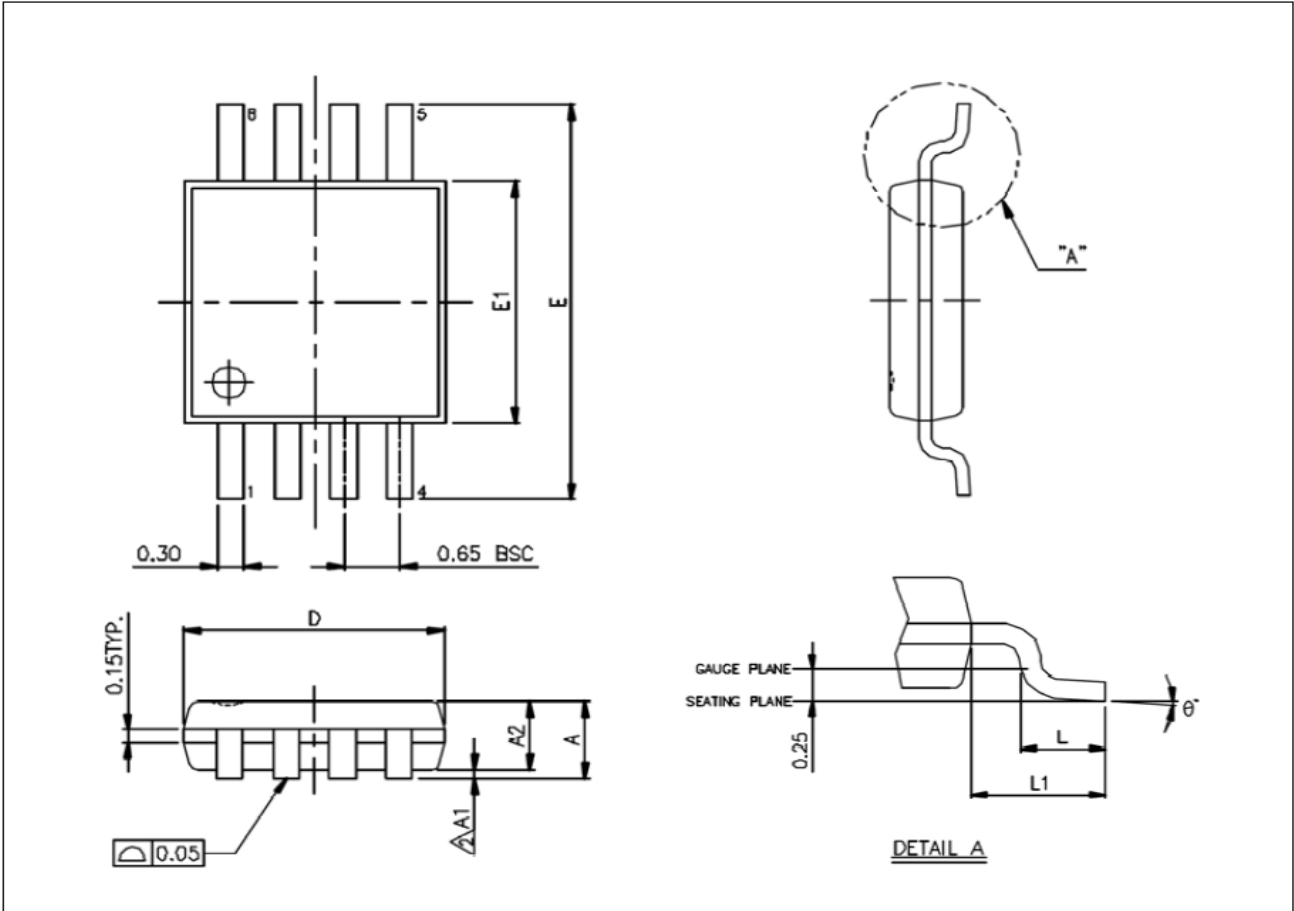

Unit: mm

Symbols	Min. (mm)	Max. (mm)
A		1.100
A1	0.000	0.150
A2	0.750	0.950
D	3.000 BSC	
E	4.900 BSC	
E1	3.000 BSC	
L	0.400	0.800
L1	0.950 REF	
θ°	0°	8°

Note:

1. Package dimensions are in compliance with JEDEC outline: MO-187 AA.
2. Dimension "D" does not include molding flash, protrusions or gate burrs.
3. Dimension "E1" does not include inter-lead flash or protrusions.