

DESCRIPTION: 2B // QUIK-LOQ // M // PANEL MOUNT // SOLDER CUP // NON-LATCH*

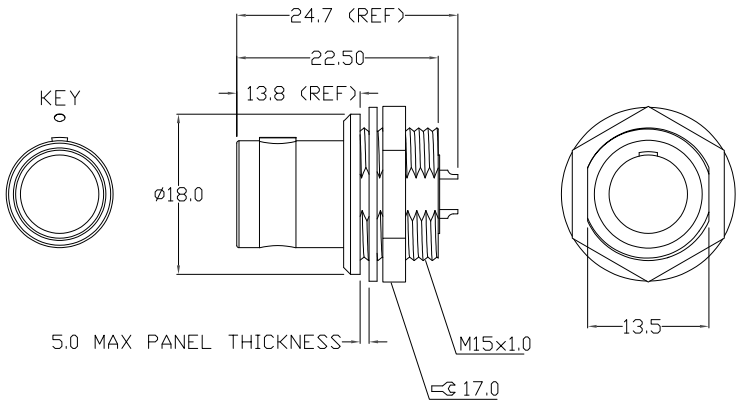
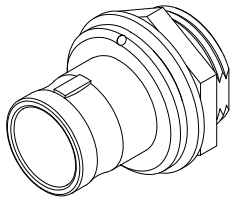

822BYYY-103R001

SERIES _____
 POSITIONS _____
 YYY = SEE POSITION CHART
 GENDER _____
 1 = MALE
 TYPE _____
 0 = SOLDER CUP PANEL MOUNT (NON-LATCH)
 KEY ORIENTATION _____
 3 = 1 KEY // 0°
 CONTACT PLATING _____
 1 = 7μ" GOLD PLATED

SPECIFICATIONS:

MATERIALS:
 SHELL: NICKEL/CHROME PLATED BRASS
 CONTACTS: 7u" GOLD PLATED BRASS
 NUT: NICKEL/CHROME PLATED BRASS
 INSULATOR: PPS (HIGH TEMPERATURE)

MECHANICAL:
 MATING CYCLES: 5000 CYCLES
 OPERATING TEMPERATURE: -40°C TO +200°C
 PROCESS TEMPERATURE: 260°C FOR 5 SECONDS
 SHIELDING: 75dB @ 10MHz // 40dB @ 1GHz
 IP RATING: 50
 MAX TORQUE: 4.5 Nm

POSITION CHART // ELECTRICAL/WIRE SPECIFICATIONS						
*solder side view of insulator						
POSITIONS	CONTACTS*	CONTACT Ø	MAX CONTACT mΩ	WORKING VOLTAGE	MAX AMPERAGE	MAX WIRE AWG
002		2.00mm	3.0 mΩ	700 V	25.0 A	16
003		1.60mm	4.0 mΩ	800 V	17.0 A	18
004		1.30mm	5.0 mΩ	615 V	15.0 A	20
006		1.30mm	5.0 mΩ	450 V	12.0 A	20
008		0.90mm	6.0 mΩ	500 V	10.0 A	22
010		0.90mm	6.0 mΩ	500 V	8.0 A	22
012		0.70mm	7.5 mΩ	480 V	7.0 A	24
014		0.70mm	7.5 mΩ	380 V	6.5 A	24
016		0.70mm	7.5 mΩ	315 V	6.0 A	24
019		0.70mm	7.5 mΩ	315 V	5.0 A	24
026		0.50mm	10.0 mΩ	315 V	2.0 A	28

*WILL NOT LATCH WITH NORCOMP 822B SERIES FEMALE CABLE MOUNT CONNECTORS DUE TO NO LATCH MECHANISM WITHIN CONNECTOR.

RoHS COMPLIANT

UNITS = mm

DO NOT SCALE FROM DRAWING



THESE DRAWINGS AND SPECIFICATIONS ARE THE PROPERTY OF NorComp AND SHALL NOT BE REPRODUCED, COPIED OR USED AS THE BASIS FOR THE MANUFACTURE OR SALE OF APPARATUS WITHOUT WRITTEN PERMISSION.

DRAWN: M. SIGMON
 DATE: 02/05/2016

NorComp

SCALE: NTS
 SHEET 1 OF 1
 REV 5
 DWG NO. 822BYYY-103R001