

编号	SCTF2022LC915
日期	2022-9-19
版本	B01

承认书

SPECIFICATION FOR APPROVAL

客户名称 Customer Name : 立创商城

供应商物料名称 Part Name : 差分石英晶体振荡器

产品描述 Description : OSC7050 150.000MHz 3.3V LVDS ±20ppm

供应商物料料号 Part NO. : SX7M150.000B20F30DNN

供应商名称 Supplier Name : 深圳市星通时频电子有限公司

PLEASE CONFIRM OUR SPECIFICATION。敬请确认规格书之内容。

CUSTOMER APPROVAL 客户审批		
物料代号 PART NO. _____		
使用于机型 USED IN MODEL: _____		
工程部	品质部	采购部

(敬请确认后返回一份, 谢谢!)

SUPPLIER APPROVAL 供应商审批		
DGN. 制表人	CKD. 校对	APPR. 审核/印章
吴丽红	李霞	

地址: 深圳市南山区龙珠四路方大城T2栋10楼

Add: 10 / F, Building T2, Fangdacheng, Longzhu 4th Road, Nanshan District, Shenzhen, China.

Website: www.sctf-crystal.com

Email: info@sctf-crystal.com

TEL: 0755-86097430

FAX: 0755-86097259



产品规格书
SPECIFICATION FOR APPROVAL

1	Cover 封面.....	Page 1
2	Contents 目录.....	Page 2
3	Revised Page 修改页.....	Page 3
4	Specifications of Oscillator 规格书.....	Page 4
5	Test Circuit & Output Waveform 测试电路与输出波形.....	Page 5
6	Dimensions 尺寸图.....	Page 6
7	Product Structure & Marking 结构与印字.....	Page 7
8	Reflow Profiles 回流焊.....	Page 8
9	Reliability Specification 可靠性测试.....	Page 9
10	Package 包装.....	Page 10

SHENZHEN SCTF ELECTRONICS CO. , LTD		
DATE	Specification of Quartz Crystal Oscillator 石英晶体振荡器规格书	PAGE
2022-9-19	P/N: SX7M150.000B20F30DNN Spec. NO. : SCTF2022LC915	2

3 Revised Page

Rev.	Revise page	Revise Contents	Date	Ref. No.	Reviser
1	N/A	Initial released	2022-9-19	N/A	吴丽红

SHENZHEN SCTF ELECTRONICS CO. , LTD		
DATE	Specification of Quartz Crystal Oscillator 石英晶体振荡器规格书	PAGE
2022-9-19	P/N: SX7M150.000B20F30DNN Spec. NO. : SCTF2022LC915	3

4 QUARTZ CRYSTAL UNIT SPECIFICATION

■ Electrical Specification 电气参数

No.	Item	Symb.	Electrical Spec.	Unit	Notes
1	Holder Type 封装		SMD 7050		
2	Nominal Frequency 标称频率	Fo	150.000000	MHz	
3	Frequency Stability 常温频差	Fo_tol	± 20	ppm	T_use = + 25°C
4	Temperature Drift 温度频差	Fo_Tc	± 30	ppm	T_use = - 40°C ~ +85 °C
5	Operating Voltage 工作电压	VDD	3.3	V	± 10% max.
6	Output 输出模式		LVDS		
7	Output Load 负载		100	Ω	
8	Current Consumption 消耗电流	Icc	75 Max.	mA	At maximum supply voltage
9	Operating Temperature Range 工作温度范围	T_use	-40~+85	°C	
10	Storage Temperature Range 保存温度范围	T_stg	-55~+125	°C	
11	Duty Cycle 占空比	TH/T	45 ~ 55	%	
12	Rise / Fall Time 上升/下降沿时间	Tr/Tf	1.0 Max.	ns	
13	Low Output Voltage 低电平	VoL	0.9 Min.	V	
14	High Output Voltage 高电平	VoH	1.6 Max.	V	
15	Start-up Time 启动时间	S_T	3.0 Max.	ms	
16	Enable Voltage High (Logic 1) 使能高电平	Vhi	70% Vdd Min.	V	Logic "1" Or Floating input, Outputs enable; Logic "0", Outputs disable 输出使能OE是高电平1或者悬空,频率输出 输出使能OE是低电平0,则无频率输出
17	Enable Voltage Low (Logic 0) 使能低电平	Vlo	30% Vdd Max.	V	
18	RMS Phase Jitter 抖动		0.5 Max.	pSec	Period Jitter(12KHz-20MHz)
19	Aging 老化	f_age	± 3.0	ppm	First year at 25°C

SHENZHEN SCTF ELECTRONICS CO., LTD

DATE	Specification of Quartz Crystal Oscillator 石英晶体振荡器规格书	PAGE
2022-9-19	P/N: SX7M150.000B20F30DNN Spec. NO. : SCTF2022LC915	4

5 TEST CIRCUIT & OUTPUT WAVEFORM

■ TESTING CIRCUIT 测试电路

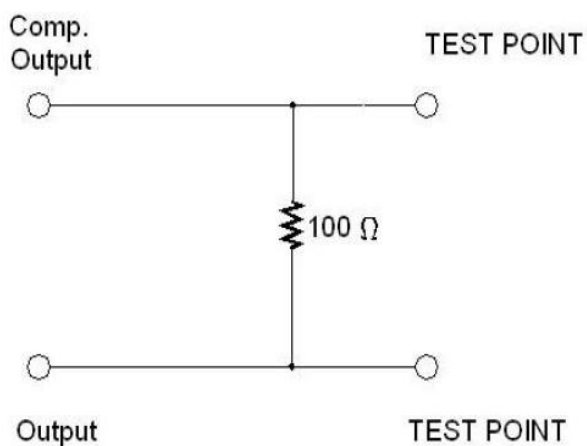

■ WAVEFORM CONDITIONS 输出波形

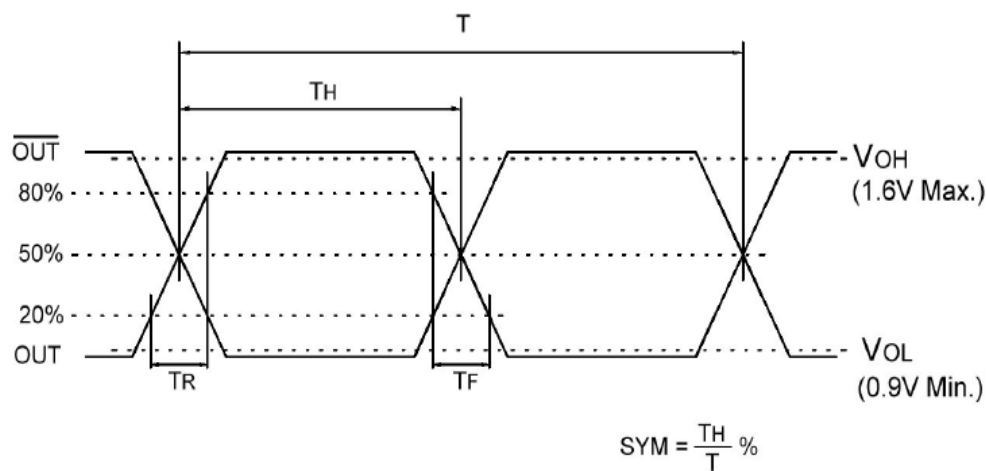

SHENZHEN SCTF ELECTRONICS CO. , LTD

DATE

Specification of Quartz Crystal Oscillator
石英晶体振荡器规格书

PAGE

2022-9-19

P/N: SX7M150.000B20F30DNN
Spec. NO. : SCTF2022LC915

5

6 DIMENSIONS

■ DIMENSIONS 产品尺寸

Units (单位): mm(毫米)

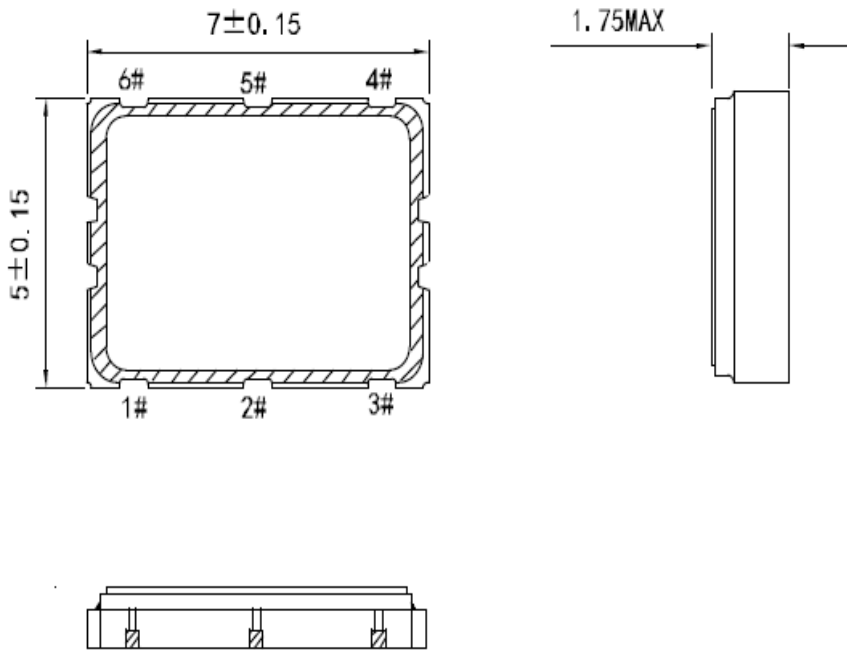

Pin	Function
#1	Tri-State
#2	N.C
#3	GND.
#4	Output
#5	Comp. Output
#6	V _{DD}

■ Pad size 焊盘尺寸

Buttom View

Suggested solder pad layout

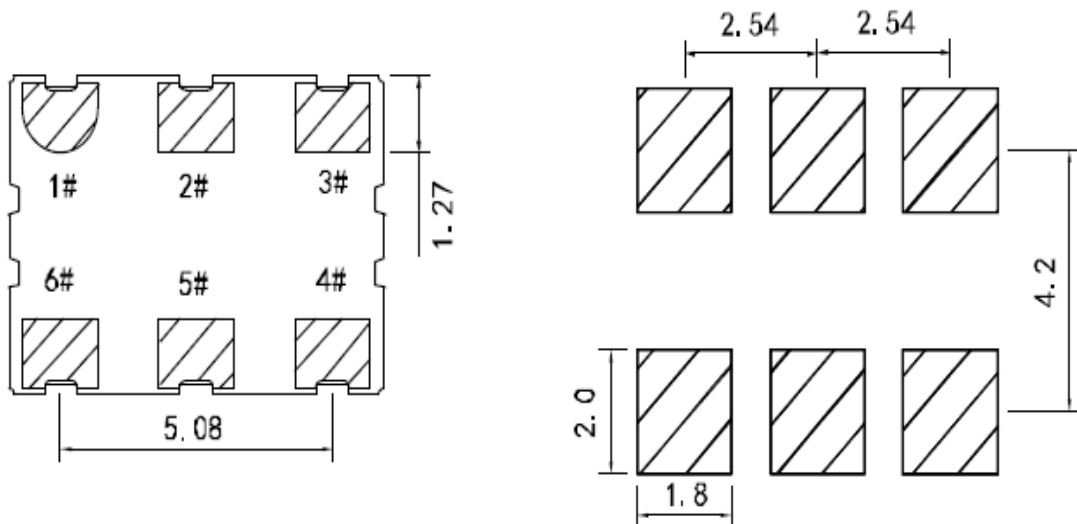

SHENZHEN SCTF ELECTRONICS CO., LTD

DATE	Specification of Quartz Crystal Oscillator 石英晶体振荡器规格书	PAGE
2022-9-19	P/N: SX7M150.000B20F30DNN Spec. NO. : SCTF2022LC915	6

7 PRODUCT STRUCTURE & MARKING

■ Product Structure 产品结构

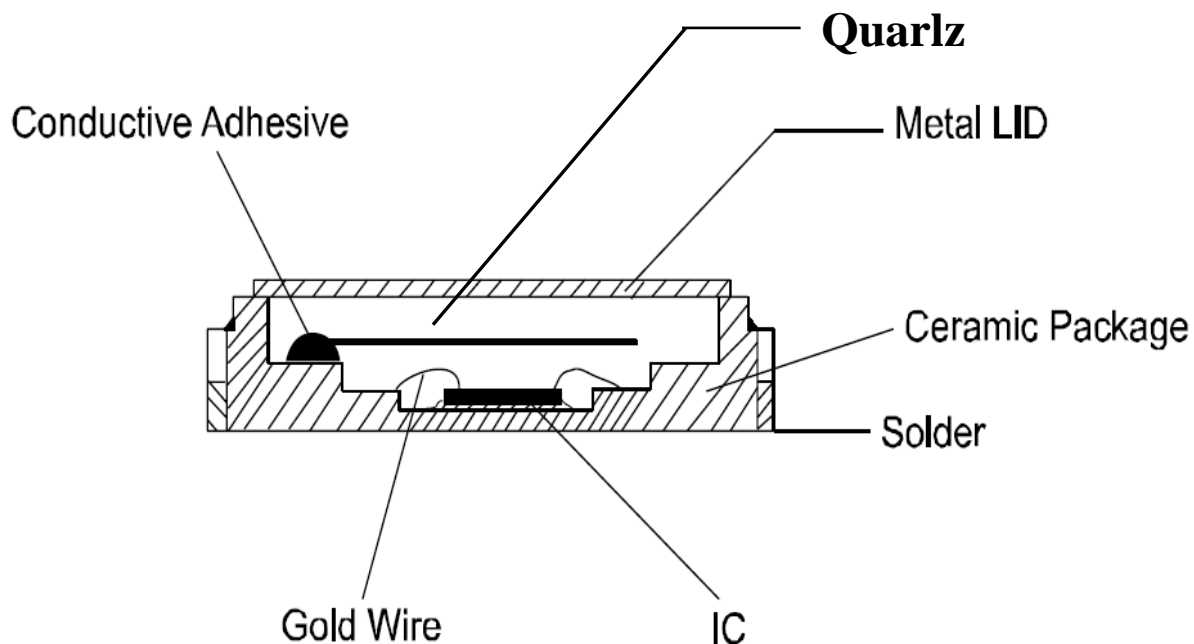

■ Marking 印字

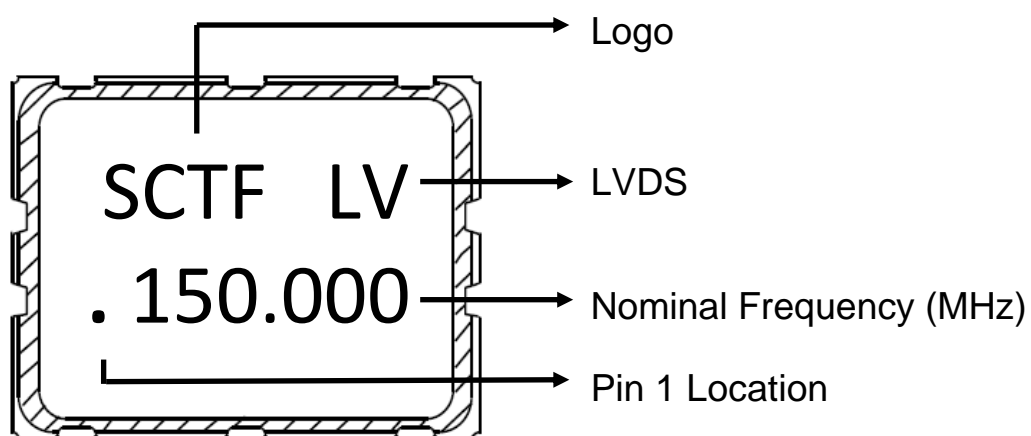

SHENZHEN SCTF ELECTRONICS CO., LTD		
DATE	Specification of Quartz Crystal Oscillator 石英晶体振荡器规格书	PAGE
2022-9-19	P/N: SX7M150.000B20F30DNN Spec. NO. : SCTF2022LC915	7

8 REFLOW PROFILES

REFLOW PROFILES 回流焊条件

Profile Feature	Sn-Pb Eutectic Assembly	Pb-Free Assembly
Preheat/Soak		
● Temperature Min(T_s min)	100 °C	150 °C
● Temperature Max (T_s max)	150 °C	200 °C
● Time (T_s min to T_s max)	60-120 seconds	60-120 seconds
Ramp-up rate (TL to T_p)	3 °C/second max.	3 °C/second max.
Time maintained above		
● Liquidous temperature (TL)	183 °C	217 °C
● Time (t_L) maintained above TL	60-150 seconds	60-150 seconds
Peak package body temperature (T_p)	235 °C	260 °C
Time within 5 °C of the specified	20 seconds	30 seconds
Ramp-down rate (T_p to TL)	6 °C/second max.	6 °C/second max.
Time 25 °C to peak temperature	6 minutes max.	8 minutes max.
Suggest reflow times	2 Times max.	

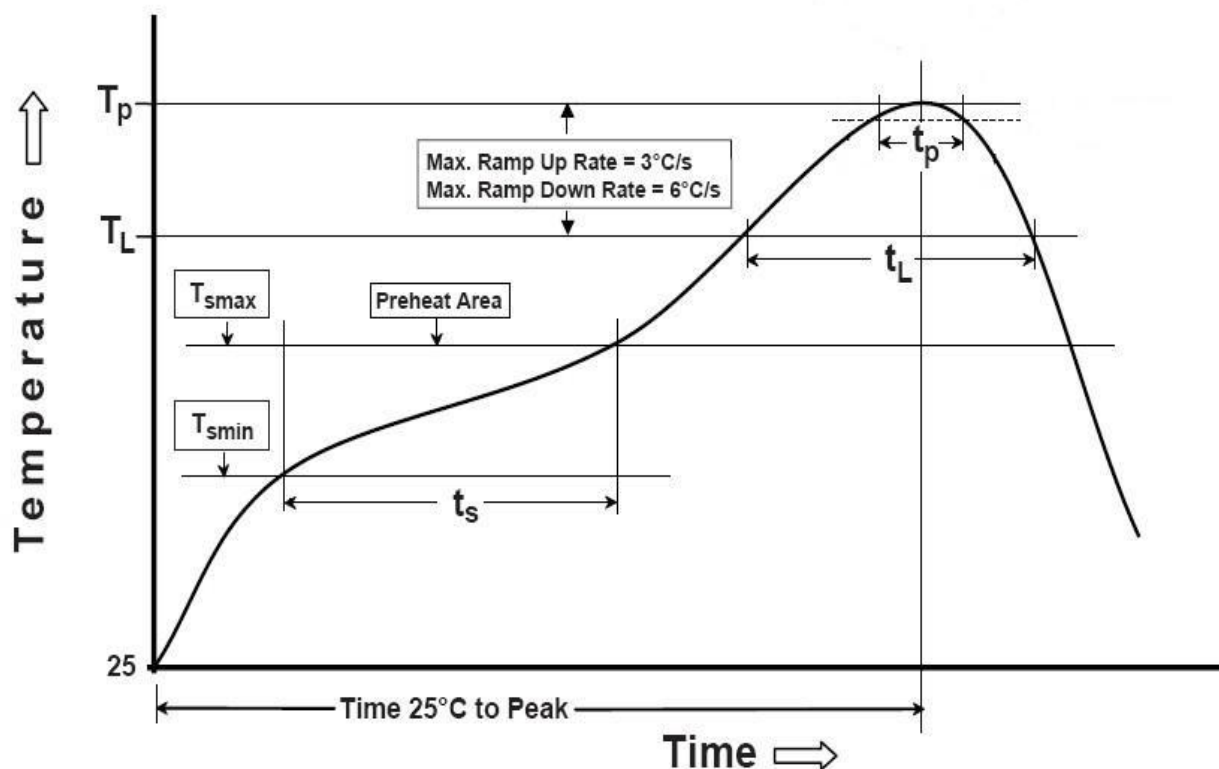

SHENZHEN SCTF ELECTRONICS CO., LTD

DATE

Specification of Quartz Crystal Oscillator
石英晶体振荡器规格书

PAGE

2022-9-19

P/N: SX7M150.000B20F30DNN
Spec. NO. : SCTF2022LC915

8

9 RELIABILITY SPECIFICATION

■ Environmental and mechanical characteristics 可靠性参数

No.	项目 ITEM	条件 CONDITIONS	合格标准 BASIS OF VERDICT
1	跌落 DROP	100cm高处自由跌落到3cm厚木板上,3次 High:100cm;Thickness:3cm;3 times.	$\Delta FL \leq \pm 5PPM$
2	振动 VIBRATION	频率 Frequency:10~57.7Hz:幅度 Amplitude: $\pm 0.75mm$ 频率Frequency:57.7Hz~500Hz:加速度幅度acceleration rate:98m/s2 周期 Cycle time:10-500-10Hz: 15min 振动方向 Direction:X,Y, Z 振动时间 Duration: 每个方向2小时 2 h/direction.	$\Delta FL \leq \pm 5PPM$
3	温度变化 TEMPERATURE SHOCK	$-40^{\circ}C \pm 2^{\circ}C$ (30min) $\leftarrow \rightarrow 85^{\circ}C \pm 2^{\circ}C$ (30min);循环10次 $-40^{\circ}C \pm 2^{\circ}C$ (30min) $\leftarrow \rightarrow 85^{\circ}C \pm 2^{\circ}C$ (30min);For 10	$\Delta FL \leq \pm 5PPM$
4	湿热 HUMIDITY	cycles 温度: $40^{\circ}C \pm 2^{\circ}C$;湿度90-95%;时间:96小时 Temp: $40^{\circ}C \pm 2^{\circ}C$;Humidity:90-95%;Times:96h	$\Delta FL \leq \pm 5PPM$
5	低温 COLD RESISTANCE	温度: $-40^{\circ}C \pm 2^{\circ}C$;时间:96小时 Temp: $-40^{\circ}C \pm 2^{\circ}C$;Times:96h	$\Delta FL \leq \pm 5PPM$
6	高温1 HEAT RESISTANCE 1	温度: $100^{\circ}C \pm 2^{\circ}C$;时间:96小时 Temp: $100^{\circ}C \pm 2^{\circ}C$;Times:96h	$\Delta FL \leq \pm 5PPM$
7	高温2 HEAT RESISTANCE 2	温度: $155^{\circ}C \pm 2^{\circ}C$;时间:2小时 Temp: $155^{\circ}C \pm 2^{\circ}C$;Times:2h	$\Delta FL \leq \pm 5PPM$
8	高温3 HEAT RESISTANCE 3	温度: $85^{\circ}C \pm 2^{\circ}C$;电压:3.3V/5.0V;时间:96小时 Temp: $85^{\circ}C \pm 2^{\circ}C$;Voltage:3.3V/5.0V;Times:96h	$\Delta FL \leq \pm 5PPM$
9	回流焊 REFLOW	$150^{\circ}C \pm 5^{\circ}C$ 保持120s后升到 $270^{\circ}C \pm 5^{\circ}C$ 保持10s, 升温和 保温时间小于200s, 常温放置1~2h后测定 Keep $150^{\circ}C \pm 5^{\circ}C$ 120s and then rose to $270^{\circ}C \pm 5^{\circ}C$ for 10s, warming and holding time is less than the 200s, placed at room temperature 1 ~ 2h after test	$\Delta FL \leq \pm 5PPM$
10	盐雾 SALT SPRAY	盐雾浓度:5%;温度: $35^{\circ}C$;时间:24小时 Salt density:5%;Temp: $35^{\circ}C$;Times:24h	目测无明显腐蚀现象 Visual no significant
11	老化 AGING	温度: $85^{\circ}C$;时间:30天 Temp: $85^{\circ}C$;Times:30days	$\Delta FL \leq \pm 5PPM$
12	气密性 LEAKAGE	氦气(0.6~0.65MPa):10分钟 He(0.6~0.65MPa):10min	$\leq 3 \times 10^{-9} Pa \cdot m^3/s$
13	焊接 SOLDER	温度: $260^{\circ}C \pm 5^{\circ}C$ Temp: $260^{\circ}C \pm 5^{\circ}C$	浸锡率大于90% Soldering tin

SHENZHEN SCTF ELECTRONICS CO., LTD

DATE	Specification of Quartz Crystal Oscillator 石英晶体振荡器规格书	PAGE
2022-9-19	P/N: SX7M150.000B20F30DNN Spec. NO. : SCTF2022LC915	9

10 PACKAGE

■ Taping Specifications 编带

UNIT(单位):mm(毫米)

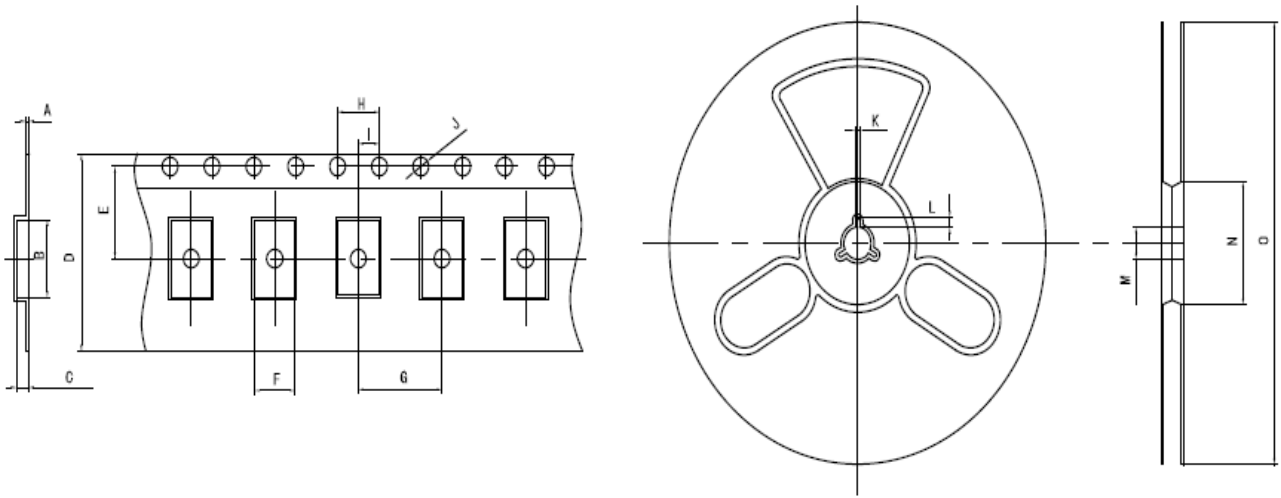

TEYE	A	B	C	D	E	F	G	H	I	J	K	L	M	N	O
5×7 SMD	0.3	7.5	1.8	16.0	7.5	5.5	8.0	4.0	2.0	1.5	2.0	4.0	13.0	60.0	180.0

■ Packaging specifications 包装

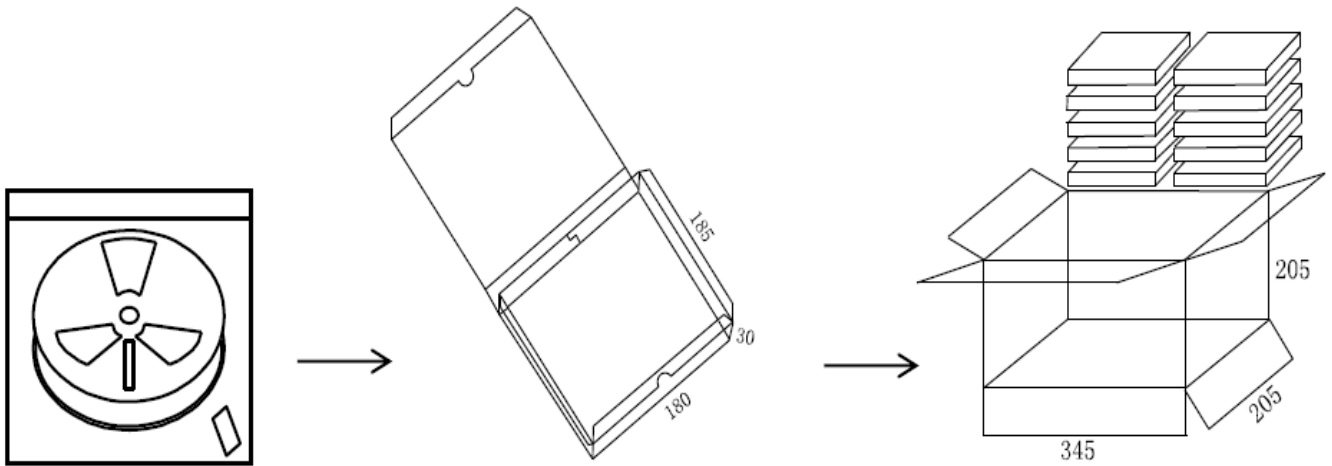

自封袋 (Bag)
1000只 = 1 轮
1000pcs = 1 Reel

内包装 (Inside package)
1 轮 = 1 盒
1 Reel = 1 box

外包装 (Outside Package)
10 盒 = 1 箱
10 box = 1 carton

SHENZHEN SCTF ELECTRONICS CO., LTD

DATE	Specification of Quartz Crystal Oscillator 石英晶体振荡器规格书	PAGE
2022-9-19	P/N: SX7M150.000B20F30DNN Spec. NO. : SCTF2022LC915	10