

●Product features and main applications:

NPNPN five-layer structure of silicon bidirectional devices; with independent intellectual property rights of single-sided digging technology, table glass passivation process; multi-layer metallized electrodes on the back; with high blocking voltage and high temperature stability.

Mainly used in:

vacuum cleaners, power tools and other motor speed controllers; solid state relays; heating controllers (temperature regulation); other phase control circuits.

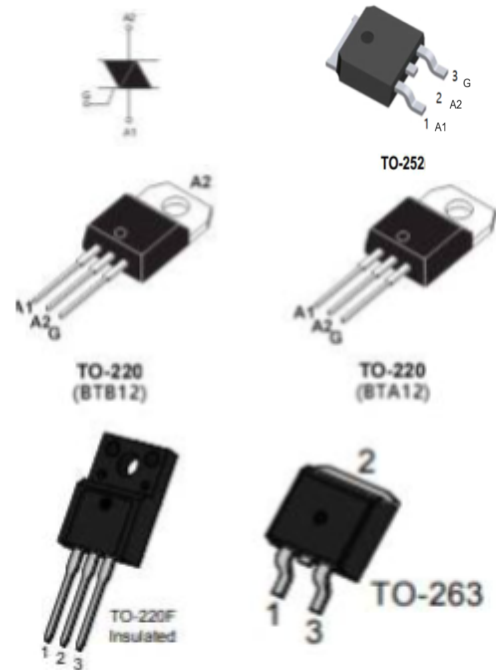

●Characteristics

Table 1. Absolute maximum ratings (Tj = 25 ° C unless otherwise stated)

Symbol	Parameter name		value	Unit
$I_{T(RMS)}$	RMS on-state current (full sine wave)	BTA BTB	Tc=80°C Tc=90°C	16 A
I_{TSM}	Non repetitive surge peak on-state current (full cycle, Tj initial = 25 ° C)	F=50HZ tp=20ms		160 A
I^2t	I ² t value for fusing	tp=10ms		144 A ² S
di/dt	Critical rate of rise of on-state current IG = 2 x IGT, tr ≤ 100 ns	Tj=125°C		50 A/us

BT139 - 800 Bidirectional Thyristor

V_{DRM}/V_{RRM}	Off state repetitive peak voltage Reverse repetitive peak voltage	$T_j=25^{\circ}\text{C}$		600/800	V
I_{GM}	Peak gate current	$t_p=20\mu\text{s}$	$T_j=150^{\circ}\text{C}$	4	A
$P_{G(AV)}$	Average gate power dissipation		$T_j=150^{\circ}\text{C}$	1	W
T_{stg} T_j	Storage junction temperature range Operating junction temperature range			$-40\text{to}+150$ $-40\text{to}+125$	$^{\circ}\text{C}$

● Table 2. Electrical characteristics ($T_j = 25^{\circ}\text{C}$, unless otherwise specified) --3 quadrants

Symbol	Name and test conditions	Quadrant	Range	value		Unit
I_{GT}	$V_D=12\text{V}$ $R_L=100\Omega$	I II III	MAX	≤ 50		mA
V_{GT}			MAX	1.5		V
V_{GD}	$V_D = V_{DRM}$, $R_L = 3.3\text{ k}\Omega$, $T_j = 125^{\circ}\text{C}$		MIN	0.2		V
I_H	$I_T = 100\text{ mA}$		MAX	60		mA
I_L	$I_G = 1.2 \times I_{GT}$		MAX	I -III	60	mA
				II	100	
dv/dt	$V_D = 67\% V_{DRM}$, gate open, $T_j = 125^{\circ}\text{C}$		MIN	500		V/us
$(dv/dt)_c$	Critical rise rate of commutation voltage $T_j = 150^{\circ}\text{C}$		MIN	10		V/us

●Table 3. Electrical characteristics (Tj = 25 ° C, unless otherwise specified) - Standard Triac (4 quadrants)

Symbol	Name and test conditions	Quadrant	Range	value	Unit
I _{GT}	V _D =12V R _L =100Ω	I II III IV	MAX	I II III	mA
				IV	
≤ 50	≤ 120				
V _{GT}	MAX		1.5	V	
V _{GD}	V _D = V _{DRM} , R _L = 3.3 kΩ, T _j = 125 ° C	MIN	0.2	V	
I _H	I _T =500mA	MAX	60	mA	
I _L	I _G = 1.2 x I _{GT}	MAX	60	mA	
			100		
dv/dt	V _D = 67% V _{DRM} , gate open, T _j = 125 ° C	MIN	500	V/us	
(dv/dt) _c	Critical rise rate of commutation voltage T _J = 150 ° C	MIN	10	V/us	

●Static parameters

Symbol	Parameter name			value	Unit
V _{TM}	I _{TM} = 32A	T _j =25°C	MAX	1.50	V
V _{T0}	threshold on-state voltage	T _j =150°C	MAX	0.87	V
R _d	Dynamic resistance	T _j =150°C	MAX	14.6	mΩ
I _{IDRM} I _{IRRM}	V _{DRM} = V _{RRM}	T _j =25°C	MAX	5	uA
		T _j =150°C		1	mA
R _{th(j-c)}	Junction to ambient	BTA		2.10	°C/W
		BTB		1.30	

● BT139-800 characteristic curve

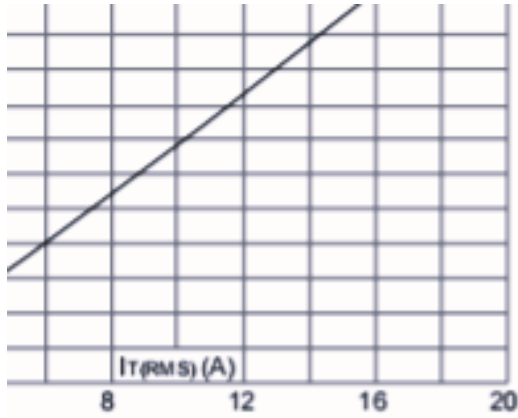

peak on-state current versus cycles

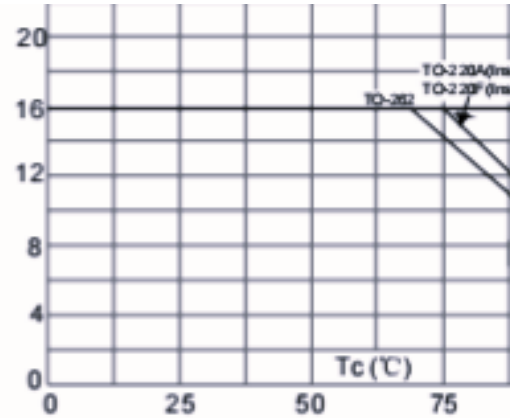

FIG.4: On-state characteristics (n values)

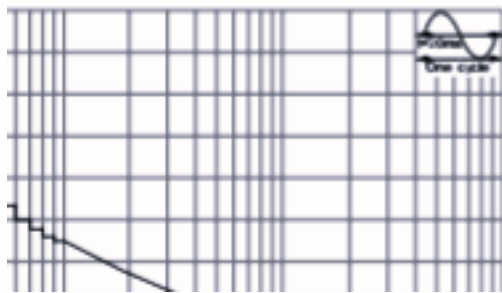

FIG.5: Non-repetitive surge peak on-state current for a sinusoidal pulse with width $t_p < 20\text{ms}$, and corresponding value of I^2t ($di/dt < 50\text{A}/\mu\text{s}$)

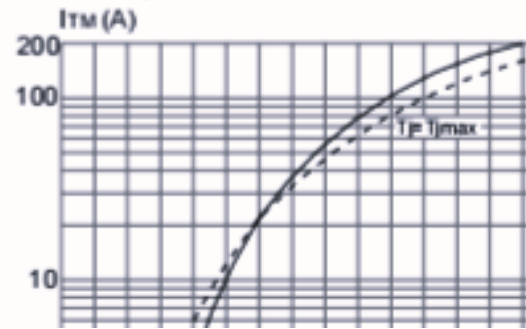
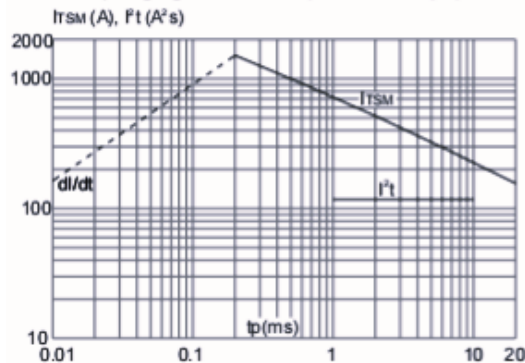
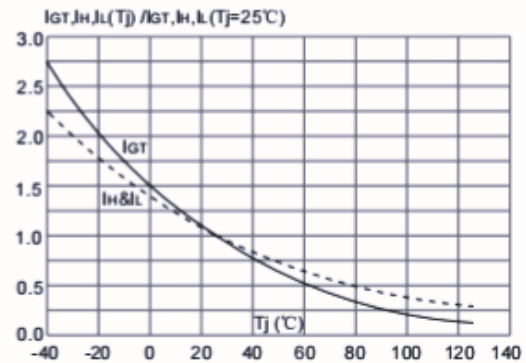
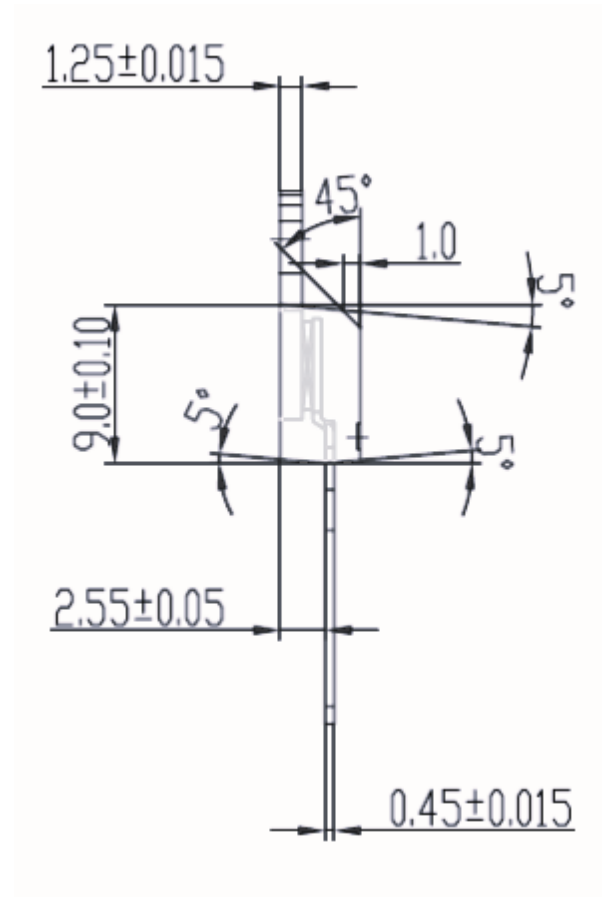
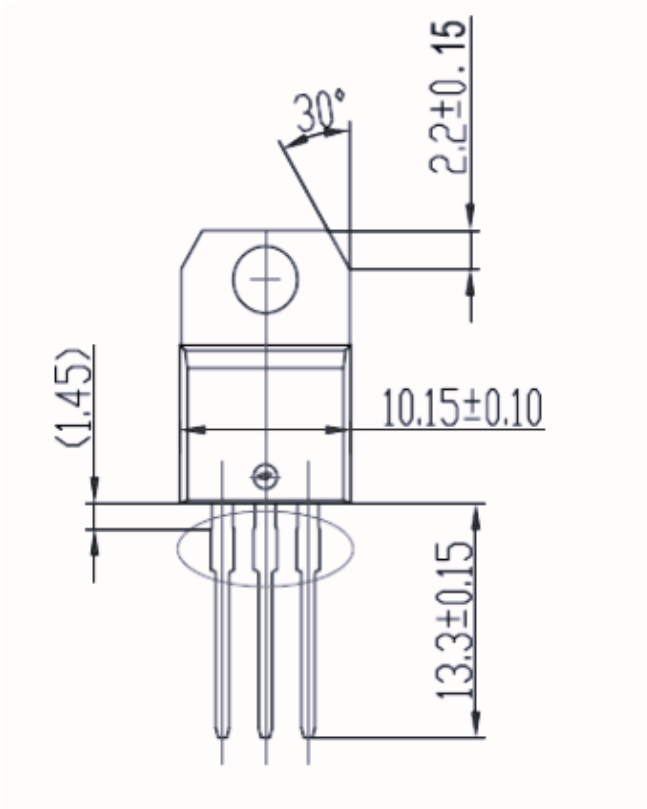

FIG.6: Relative variations of gate trigger current, holding current and latching current versus junction temperature



● TO-220 Dimensional drawing:

Unit: mm (± 0.1)



● TO-220F Dimensional drawing:

Unit: mm (± 0.1)

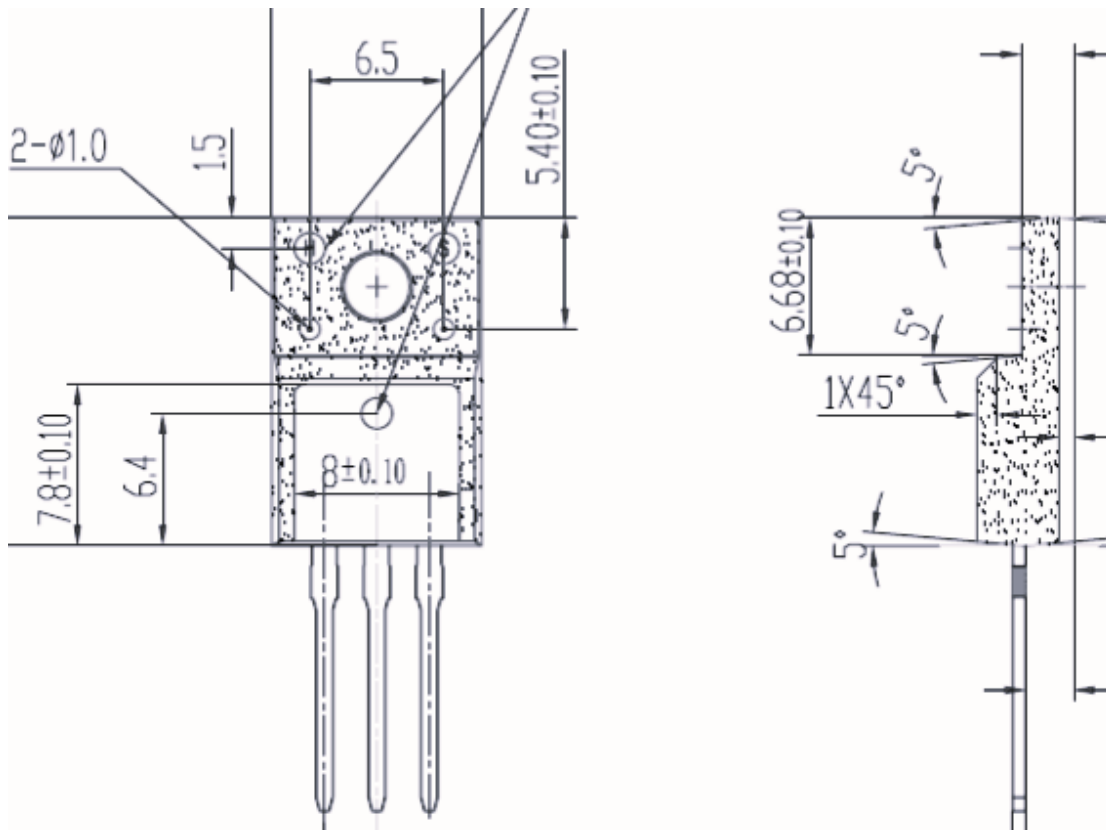

●TO-263 Dimensional drawing:

Unit: mm (± 0.1)

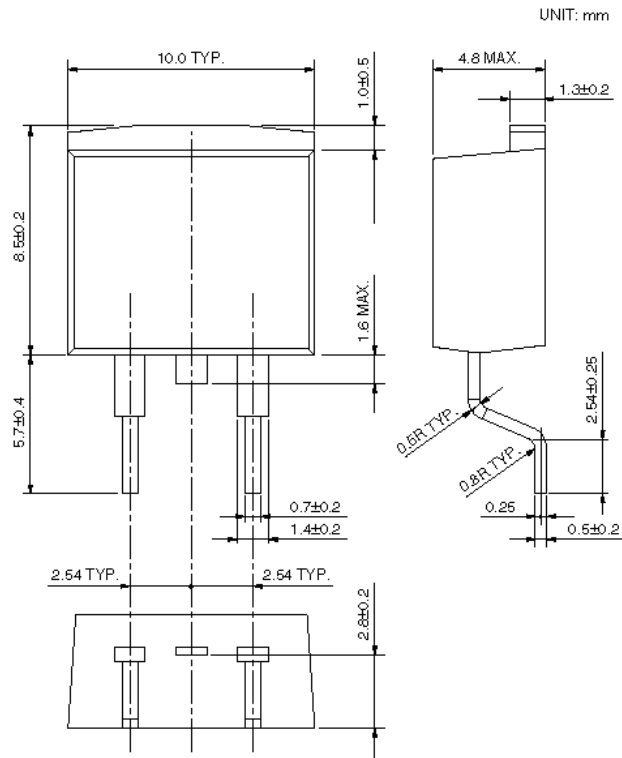

: The area without solder plated

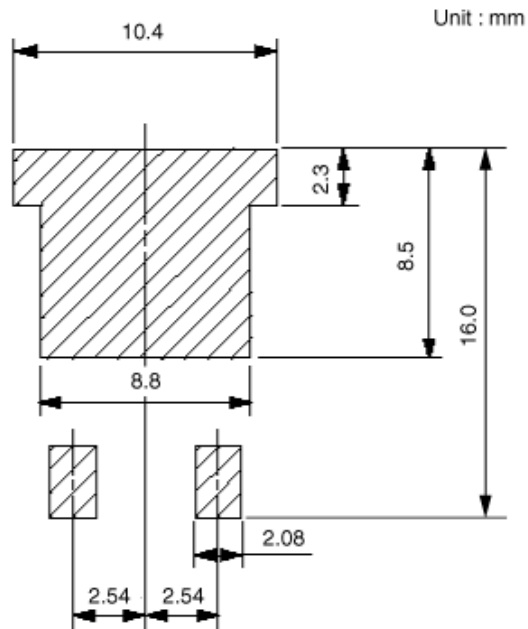

● TO-252 Dimensional drawing:

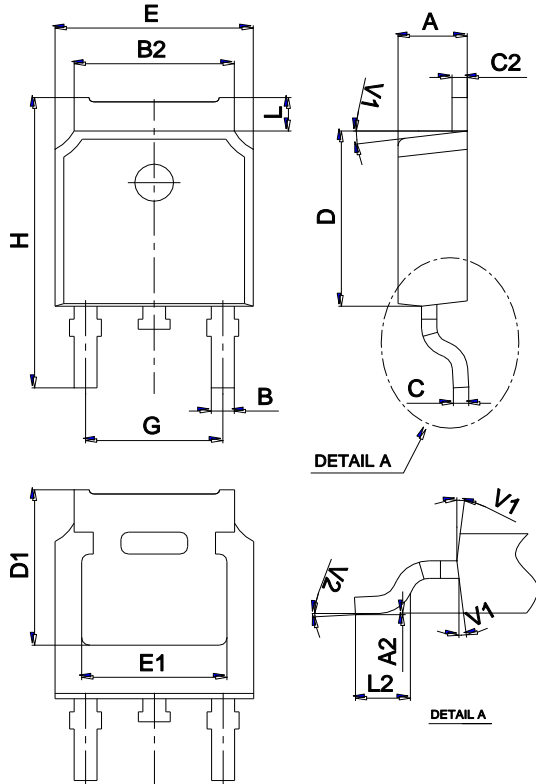

Ref.	Dimensions					
	Millimeters			Inches		
	Min.	Typ.	Max.	Min.	Typ.	Max.
A	2.10		2.50	0.083		0.098
A2	0		0.10	0		0.004
B	0.66		0.86	0.026		0.034
B2	5.18		5.48	0.202		0.216
C	0.40		0.60	0.016		0.024
C2	0.44		0.58	0.017		0.023
D	5.90		6.30	0.232		0.248
D1	5.30REF			0.209REF		
E	6.40		6.80	0.252		0.268
E1	4.63			0.182		
G	4.47		4.67	0.176		0.184
H	9.50		10.70	0.374		0.421
L	1.09		1.21	0.043		0.048
L2	1.35		1.65	0.053		0.065
V1		7°			7°	
V2	0°		6°	0°		6°

Marking

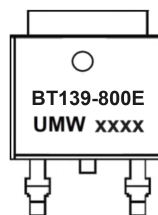

Ordering information

Order code	Package	Baseqty	Deliverymode
UMW BT139D-800E	TO-252	2500	Tape and reel