

THESE DRAWINGS ARE THE PROPERTY OF QUALTEK ELECTRONICS AND NOT TO BE REPRODUCED FOR OR COMMUNICATED TO A THIRD PARTY WITHOUT THE EXPRESS WRITTEN PERMISSION OF AN OFFICER OF QUALTEK ELECTRONICS.

REVISION			
REV.	DESCRIPTION	DATE	APPROVED
B	RoHS Compliancy	06-01-06	DP
C	Updated Specifications	01-06-10	LY

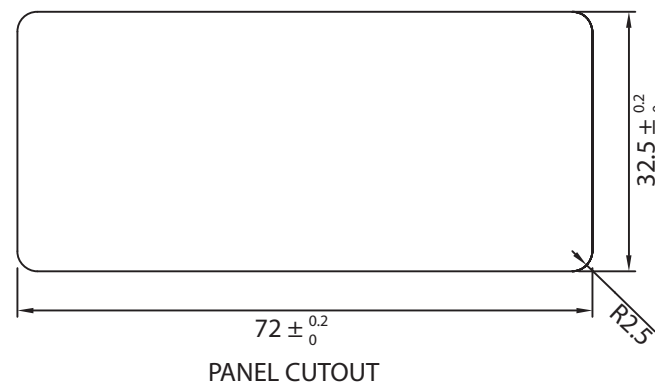
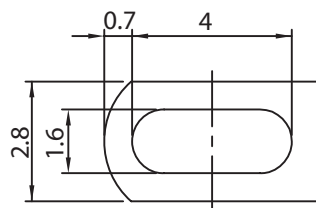
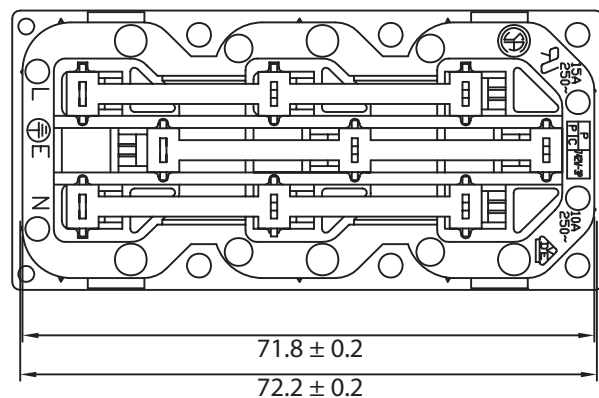
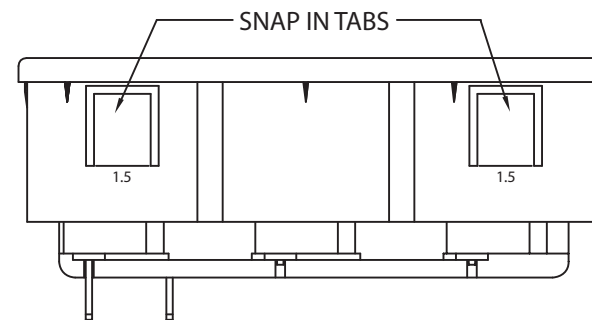
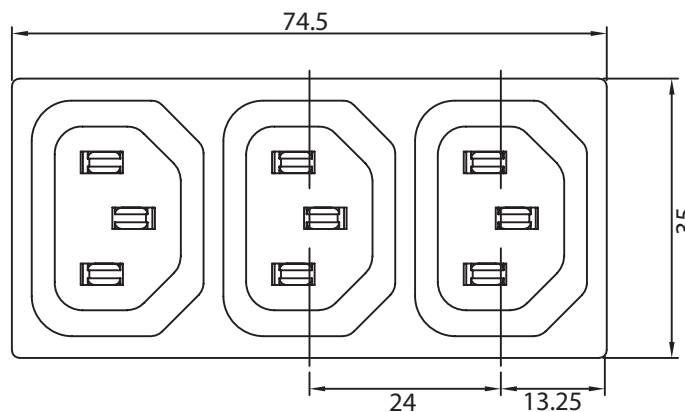
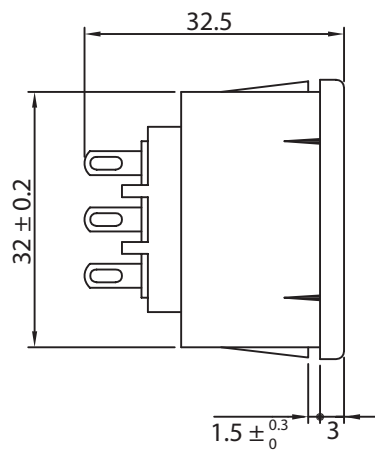

NOTES:

RATING:

UL, CSA: 15A 250V AC  
 VDE: 10A 250V AC  
 PANEL THICKNESS: 1.5mm  
 APPROVALS: UL, CSA, VDE  
 COLOR: BLACK  
 RoHS COMPLIANT

**CONTROLLED**

Dim range (mm)	Tolerance +/- (mm)	Qualtek Electronics Corp. PPC DIVISION		
0-1	0.15	Part Number: 742W-15/12		RoHS Compliant
1-6	0.20	Description: AC RECEPTACLE		
6-18	0.30		UNIT: mm	REV. C
18-50	0.50			
50-120	0.70	Drawn / Date	Checked / Date	Approved / Date
120-250	0.90	B.ZHANG 08-20-03	08-20-03	JJH / 08-20-03
250-500	1.20			