

alle Kontakte/all contacts
 ϕ 0.13 (M)

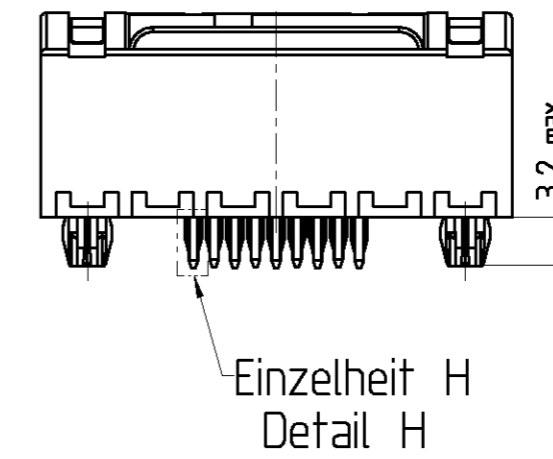

Einzelheit H (20:1)
 Detail H (20:1)

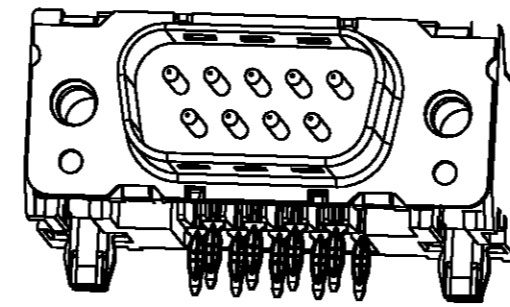
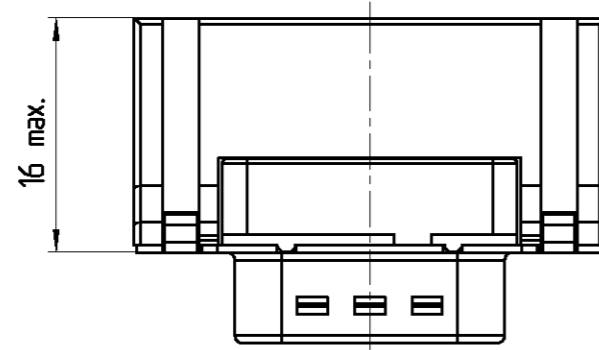
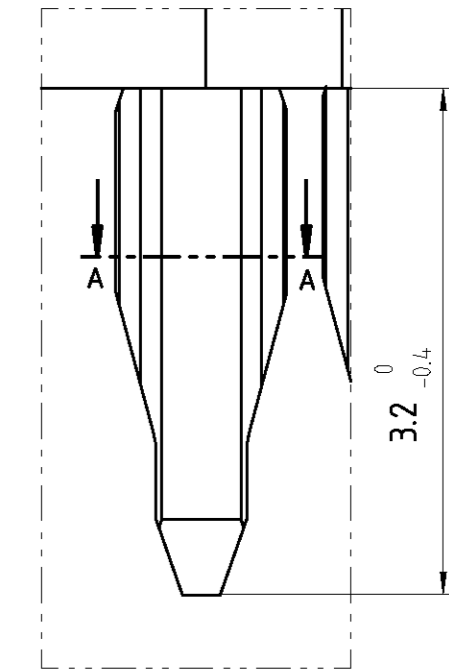

Schnitt AA (20:1)
 Section (20:1)

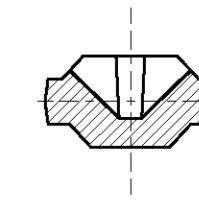

- 4) Plated-through hole ; incl. plating
 suitable for compliant press-in zone
 PCB-plating-through : 5...15 μ m Sn or SnPb over min. 25 μ m Cu
 Drilled holes : ϕ 1.15 \pm 0.025 and ϕ 3.15 \pm 0.025
- 3) torquereferentation \geq 70 Ncm
- 2) according to DIN 41611 p.5, DIN IEC 353-5; incl. plating
- 1) according to DIN 41652 p.2 and p.4

- 4) Durchmetallisierte Löcher; incl. Oberflächenbehandlung
 Geeignet für elastische Einpreßzonen
 Metallierung des Loches: 5...15 μ m Sn oder SnPb über min. 25 μ m Cu
 Bohrdurchmesser: ϕ 1.15 \pm 0.025 und ϕ 3.15 \pm 0.025
- 3) Verdrehsicherheit \geq 70 Nm
- 2) Nach DIN 41611 T.5, DIN IEC 352-5; incl. Oberflächenbehandlung
- 1) Nach DIN 41652 T.2 und T.4

Sachnr./Ordercode V23529-R1****-	Polzahl n Contacts n	Maß/Dimension				
		A	B	C	D	L
C*09	09	31.19	16.79	25.00 $\begin{smallmatrix} +0.12 \\ -0.13 \end{smallmatrix}$	2.74	6.12
C*15	15	39.52	25.12	33.30 $\begin{smallmatrix} +0.15 \\ -0.1 \end{smallmatrix}$	2.74	6.12
C*25	25	53.42	38.84	47.04 $\begin{smallmatrix} +0.13 \\ -0.13 \end{smallmatrix}$	2.76	5.99
C*37	37	69.70	55.50	63.50 $\begin{smallmatrix} +0.13 \\ -0.13 \end{smallmatrix}$	2.76	5.99

Anforderungsstufe 1)
 performance level 1)

Sachnr./Ordercode V23529-	Maß/Dimension ϕ G
R1*02-C***	M3
R1*03-C***	4-40UNC

1:1

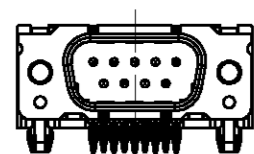

Dargestellt wird die 9-polige Ausführung V23529-R1202-C209
 On the drawing : the 9 pole version V23529-R1202-C209

APPLICABLE SPEC. :		CHANGES TO THIS DRAWING MUST BE DONE ONLY IN CAD	PAPER SIZE A2
FINISH		DIMENSIONS APPLY PLATING	
SCALE 2:1, 20:1, 1:1		WEIGHT	
MATERIAL		NO.	
DATE 7.2.96		NAME	
NAME Sterckx		Sub-D 90° abgewinkelt Standard Einpreß Stiftleiste	
APP: EC CS CI		0-Sub 90° angled standard press fit Pin	
REV. CHANGE ORDER		DATE	
DATE 14APR11		APP: HMR	
CUSTOMER DRAWING No.: C 2-1393481-5		SHT. 1	
OF 3			

Ausführung mit Gewindebolzen
Version with studbolt
V23529-R1*04/R1*05-C***

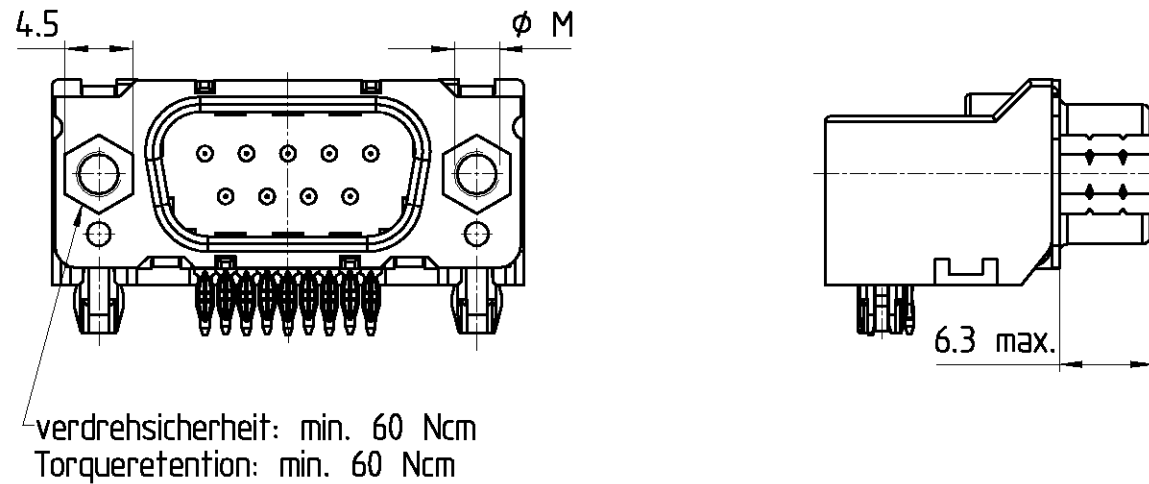

Sachnr./Ordercode V23529-	Maß/Dimension ϕM
R1*04-C***	M3
R1*05-C***	4-40UNC

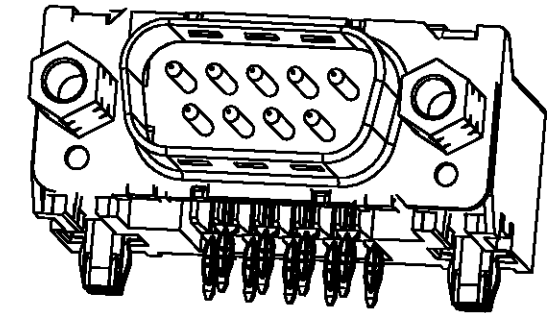

Leiterplattenbohrung (2:1)
PCB hole pattern (2:1)

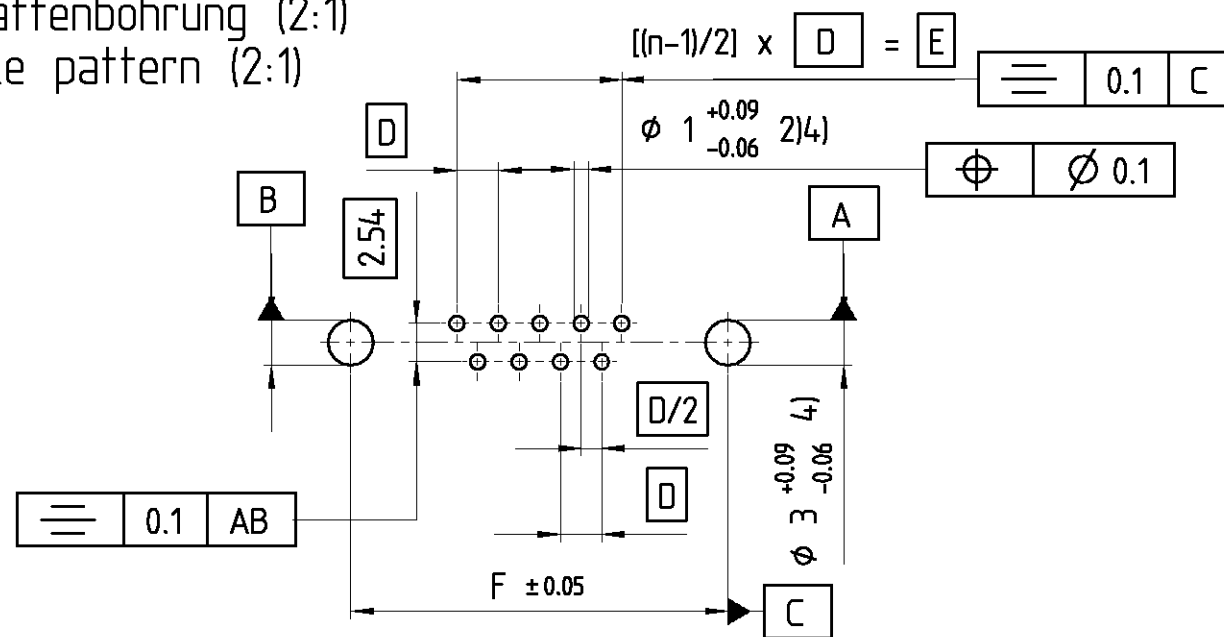

Sachnr./Ordercode V23529-R1***-	Polzahl n Contacts n	Maß/Dimension		
		D	E	F
C*09	09	2.74	10.96	25.00
C*15	15	2.74	19.18	33.30
C*25	25	2.76	33.12	47.04
C*37	37	2.76	49.68	63.50

Anforderungsstufe 1)
performance level 1)

Verpreßhinweis
press-in information

Einpressen über Kunststoff mit:

- 2-Hub-Pressen 60kN : 1-1393491-3
- Einpreßmaschine 60/100 kN : 4-1393488-2

Zu verwendenden Werkzeuge :

- Drückstück : 1393490-6
- Amboß : 3-1393489-5

Einstellhöhe : Abstand zwischen LP und
angedrucktem Stempel : 11.15 bis 11.3mm

pressing in via the plastic body :

- 2-stroke press 60kN : 1-1393491-3
- press-fit machine 60/100kN : 4-1393488-2

pressing-in tools :

- Compression tool : 1393490-6
- anvil : 3-1393489-5

set-up heights : distance between PCB and
compression tool : 11.15 to 11.3 mm

Erläuterungen siehe Seite 1
Remarks see page 1

APPLICABLE SPEC.:		FINISH	
TE Connectivity		DIMENSIONS APPLY PLATING	
SCALE 2:1		WEIGHT	
MATERIAL		NAME Sub-D 90° abgewinkelt Standard Einpreß Stiftleiste D-Sub 90° angled standard press fit Pin	
DATE 7.2.96		NO. V23529-R****-C***-7427	
NAME Sterckx		SHT. 2	
DEP. EC CS CI		OF 3	
TOLERANCE UNLESS SPECIFIED OTHERWISE		CUSTOMER DRAWING No.: C 2-1393481-5	
REV.	CHANGE ORDER	DATE	APP.

Sub-D 90° abgewinkelt Einpreß // D-Sub 90° press-in

V 2 3 5 2 9 - + * * * * - + * * *

EINBAUHÖHE // MOUNTING HEIGHT

R = Standardbauhöhe 7.3mm // Standard Style 7.3 mm

AUFBAU // CONFIGURATION

1 = isoliert // insulated
2 = geschirmt 1) // shielded 1)

BESCHRIFTUNG // MARKING

1 = tyco // tyco
2 = Neutral // neutral
3 = Sonderbeschriftung A // special marking A
4 = Sonderbeschriftung B // special marking B
5 = Sonderbeschriftung C // special marking C

ANSCHLUßAUSFÜHRUNG // CONTACT TYPE

0, 1 = EP-Stiel 3.2 mm // press-in pin 3.2 mm long

BEFESTIGUNG Steckseite/Leiterplatteseite // MOUNTING CONNECTOR/PCB

01 = Loch Ø3 / ohne Massekontakt 1) // hole Ø3 / without grounding
02 = Gewinde M3 / mit Massekontakt // thread M3 / with grounding
03 = Gewinde 4-40 UNC / mit Massekontakt // thread 4-40 UNC / with grounding
04 = Gewindebolzen M3 / mit Massekontakt // studbolt srewlock M3 / with grounding
05 = Gewindebolzen 4-40 UNC / mit Massekontakt // studbolt srewlock 4-40 UNC / with grounding

1) in Vorbereitung // in preparation

STECKERPOLZAHL // NO OF CONTACTS

09 = 9-polig // 9-contact
15 = 15-polig // 15-contact
25 = 25-polig // 25-contact
37 = 37-polig // 37-contacto rea

ANFORDERUNGSSTUFE // PERFORMANCE LEVEL

2 = Anf. II // PL II

STECKERART // CONNECTOR TYPE

C = Stiftleiste mit Schirmfiederung // male connector with grounding fingers

Active part numbers. Contact TE CONNECTIVITY for other configuration availability		
Old Part Number	TE CONNECTIVITY Part Number	
V23529-R1102-C209	2-1393481-5	OBSOLETE
V23529-R1102-C215	2-1393481-6	
V23529-R1102-C225	2-1393481-7	OBSOLETE
V23529-R1102-C237	2-1393481-8	
V23529-R1103-C209	3-1393481-2	OBSOLETE
V23529-R1103-C215	3-1393481-3	
V23529-R1103-C225	3-1393481-4	OBSOLETE
V23529-R1103-C237	2-1392010-7	OBSOLETE
V23529-R1105-C209	3-1393481-8	OBSOLETE
V23529-R1105-C215	3-1393481-9	OBSOLETE
V23529-R1105-C225	2-1393497-7	OBSOLETE
V23529-R1105-C237	4-1393481-0	OBSOLETE

CHANGES TO THIS DRAWING MUST BE DONE ONLY IN CAD		PAPER SIZE A2
APPLICABLE SPEC.:	FINISH	
DIMENSIONS APPLY		PLATING
SCALE		WEIGHT
MATERIAL		
DATE 7.2.96		NAME
NAME Sterckx		Sub-D 90° abgewinkelt Standard Einpreß Stiftleiste
APP. CI PD		D-Sub 90° angled standard press fit Pin
TOLERANCE UNLESS SPECIFIED OTHERWISE		NO.
REV. CHANGE ORDER		DATE
APP.		CUSTOMER DRAWING No.: C 2-1393481-5
		SHT. 3
		OF 3