

MK33 Series Reed Sensors

- **Features:** compact profile and surface mount, long life expectancy, improved stability for assembly process*, packed in tape and reel for easy pick and place
- **Applications:** air conditioning, metering, ladders for fluid level sensors, window and door sensors for security systems, smoke detectors, water flow gauge & others
- **Markets:** Automotive, Telecommunication, Safety & Security, Test & Measurement, Household, Medical & Others

* In comparison with our MK23 series

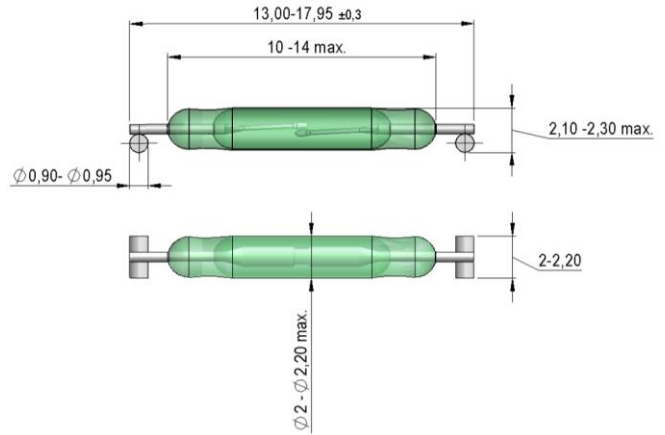

Part Description:

MK33-00-X

Switch Model	Magnetic Sensitivity	Lead Design
87, 66	B, C, D, E, F, G	compact

Customer Options	Switch Model		Unit
Contact Data	87 (10 mm Glass)	66 (14 mm Glass)	
Rated Power (max.) Any DC combination of V&A not to exceed their individual max.'s	10	10	W
Switching Voltage (max.) DC or peak AC	200	200	V
Switching Current (max.) DC or peak AC	0.4	0.5	A
Carry Current (max.) DC or peak AC	0.5	1.0	A
Contact Resistance (max.) @ 0.5V & 50mA	150	100	mOhm
Breakdown Voltage (min.) According to EN60255-5	250	250	VDC
Operating Time (max.) Incl. Bounce; Measured with w/ Nominal Voltage	0.7	0.7	Ms
Release Time (max.) Measured with no Coil Excitation	0.05	0.05	Ms
Insulation Resistance (typ.) Rh<45%, 100V Test Voltage	10 ¹⁰	10 ¹⁰	Ohm
Capacitance (typ.) @ 10kHz across open Switch	0.2	0.3	pF

MK33 Series Reed Sensors

Dimensions (mm) and Lead Specifications

Overall Length	13 - 17.95
Glass Length	10 - 14
Glass Dia.	2 - 2.2
Lead Dia.	0.90 - 0.95
Lead Design	compact

Environmental Data		Unit
Shock Resistance (max.) 1/2 sine, duration 11ms, in 3 axis	50	g
Vibration Resistance (max.)	20	g
Operating Temperature	-40 to 130	°C
Storage Temperature	-55 to 130	°C
Soldering Temperature (max.) 5 sec. max.	260	°C

Glossary Contact Form

Form A	NO = Normally Open Contacts SPST = Single Pole Single Throw	
Form B	NC = Normally Closed Contacts SPST = Single Pole Single Throw	
Form C	Changeover SPDT = Single Pole Double Throw	

Layout

Top View



Glossary Magnetic Sensitivity

Sens.	A	B	C	D	E	F	G
AT	05-10	10-15	15-20	20-25	25-30	30-35	35-40

Please note: All technical specifications on this series datasheet refer to the standard product range. Modifications in the sense of technical progress are reserved. For general information only. For more specific information, please consult the product datasheet, available upon request.

This series datasheet could contain technical inaccuracies or typographical errors. Changes are periodically made to the information herein. These change will be incorporated in future revisions.

For deviating values, most current specifications and products please contact your nearest sales office.

MK33 Reed Sensor



Handling & Assembly Instructions

- Use proper lead clamping or heat sinking techniques to prevent mechanical and/or heat stress during, soldering, and welding
- Mechanical shock as the result of dropping the reed sensor typically from a distance of greater than 12" may change it's magnetic sensitivity and/or destroy the sensor
- Reflow Soldering Conditions according to JEDEC norm J-STD-020D.1

Life Test Data

*Load increase reduces life expectancy of Reed Switches

