

### 1. Description

BL9N50, the silicon N-channel Enhanced MOSFETs, is obtained by advanced MOSFET technology which reduce the conduction loss, improve switching performance and enhance the avalanche energy. The transistor is suitable device for SMPS, high speed switching and general purpose applications.

#### KEY CHARACTERISTICS

Parameter	Value	Unit
$V_{DS@Tj,max}$	550	V
$I_D$	9	A
$R_{DS(ON).Typ}$	0.6	$\Omega$

#### FEATURES

- Fast Switching
- Low  $C_{rss}$
- 100% avalanche tested
- Improved dv/dt capability
- RoHS product

#### APPLICATIONS

- High frequency switching mode power supply
- Electronic ballast

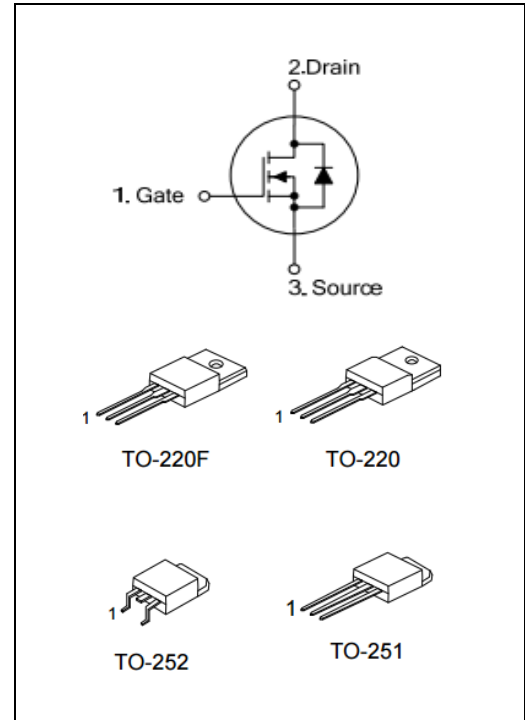

### ORDERING INFORMATION

Ordering Codes	Package	Product Code	Packing
BL9N50-P	TO-220	BL9N50	Tube
BL9N50-A	TO-220F		Tube
BL9N50-U	TO-251		Tube
BL9N50-D	TO-252		Tape Reel

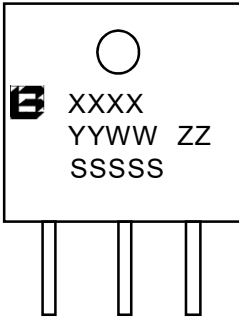
<p><b>BL9N50-A</b></p> <div style="border: 1px solid black; padding: 5px; margin: 10px 0;"> <p>(2) Package type</p> <p>(1) Chip name</p> </div> <p>(1) BL9N50:500V 9A                  (2) A:TO-220F P:TO-220                  U:TO-251 D: TO-252</p>	 <p>XXXX: Product Code                  YYWW: Year&amp;Week                  ZZ: Assembly Code                  SSSSS: Lot Code</p>
---	---

## 2. ABSOLUTE RATINGS

at  $T_C = 25^\circ\text{C}$ , unless otherwise specified

Symbol	Parameter	Rating	Units
$V_{DSS}$	Drain-to-Source Voltage	500	V
$I_D$	Continuous Drain Current	9	A
	Continuous Drain Current $T_C = 100^\circ\text{C}$	5.67	A
$I_{DM}$	Pulsed Drain Current(Note1)	36	A
$V_{GS}$	Gate-to-Source Voltage	$\pm 30$	V
$E_{AS}$	Single Pulse Avalanche Energy(Note2)	520	mJ
$dv/dt$	Peak Diode Recovery $dv/dt$ (Note3)	5.0	V/ns
$P_D$	Power Dissipation TO-220 TO-251 TO-252	160	W
	Derating Factor above $25^\circ\text{C}$	1.28	W/ $^\circ\text{C}$
$P_D$	Power Dissipation TO-220F	48	W
	Derating Factor above $25^\circ\text{C}$	0.38	W/ $^\circ\text{C}$
$T_J, T_{stg}$	Operating Junction and Storage Temperature Range	150, $-55$ to 150	$^\circ\text{C}$
$T_L$	Maximum Temperature for Soldering	300	$^\circ\text{C}$

## 3. Thermal characteristics

### Thermal characteristics TO-220

Symbol	Parameter	RATINGS	Units
$R_{\theta JC}$	Junction-to-Case	0.78	$^\circ\text{C}/\text{W}$
$R_{\theta JA}$	Junction-to-Ambient	62.5	$^\circ\text{C}/\text{W}$

### Thermal characteristics TO-220F

Symbol	Parameter	RATINGS	Units
$R_{\theta JC}$	Junction-to-Case	2.6	$^\circ\text{C}/\text{W}$
$R_{\theta JA}$	Junction-to-Ambient	62.5	$^\circ\text{C}/\text{W}$

## 4. Electrical Characteristics

 at  $T_c = 25^\circ\text{C}$ , unless otherwise specified

OFF Characteristics						
Symbol	Parameter	Test Conditions	Values			Units
			Min.	Typ.	Max.	
$V_{DSS}$	Drain to Source Breakdown Voltage	$V_{GS}=0V$ , $I_D=250\mu A$	500	--	--	V
$\frac{\Delta BV_{DSS}}{\Delta T_J}$	Bvdss Temperature Coefficient	$I_D=250\mu A$ , Reference $25^\circ\text{C}$	--	0.6	--	V/ $^\circ\text{C}$
$I_{DSS}$	Drain to Source Leakage Current	$V_{DS}=500V$ , $V_{GS}=0V$ , $T_J=25^\circ\text{C}$	--	--	1	$\mu A$
		$V_{DS}=400V$ , $V_{GS}=0V$ , $T_J=125^\circ\text{C}$	--	--	10	$\mu A$
$I_{GSS(F)}$	Gate to Source Forward Leakage	$V_{GS}=+30V$	--	--	100	nA
$I_{GSS(R)}$	Gate to Source Reverse Leakage	$V_{GS}=-30V$	--	--	-100	nA

ON Characteristics						
Symbol	Parameter	Test Conditions	Values			Units
			Min.	Typ.	Max.	
$R_{DS(ON)}$	Drain-to-Source On-Resistance	$V_{GS}=10V$ , $I_D=4.5A$ (Note4)	--	0.6	0.72	$\Omega$
$V_{GS(TH)}$	Gate Threshold Voltage	$V_{DS}=V_{GS}$ , $I_D=250\mu A$ (Note4)	2.2	--	3.8	V
$g_{fs}$	Forward Transconductance	$V_{DS}=15V$ , $I_D=4.5A$ (Note4)	--	10	--	S

Dynamic Characteristics						
Symbol	Parameter	Test Conditions	Values			Units
			Min.	Typ.	Max.	
$R_g$	Gate resistance	$f=1.0\text{MHz}$	--	2.3	--	$\Omega$
$C_{iss}$	Input Capacitance	$V_{GS}=0V$ $V_{DS}=25V$ $f=1.0\text{MHz}$	--	1330	--	PF
$C_{oss}$	Output Capacitance		--	115	--	
$C_{rss}$	Reverse Transfer Capacitance		--	3.5	--	

Switching Characteristics						
Symbol	Parameter	Test Conditions	Values			Units
			Min.	Typ.	Max.	
$t_{d(ON)}$	Turn-on Delay Time	ID =9A VDD = 250V VGS = 10V RG =10Ω	--	33	--	ns
$t_r$	Rise Time		--	31	--	
$t_{d(OFF)}$	Turn-Off Delay Time		--	81	--	
$t_f$	Fall Time		--	38	--	
$Q_g$	Total Gate Charge	ID =9A VDD =400V VGS = 10V	--	25	--	nC
$Q_{gs}$	Gate to Source Charge		--	8	--	
$Q_{gd}$	Gate to Drain ("Miller")Charge		--	7	--	

Source-Drain Diode Characteristics						
Symbol	Parameter	Test Conditions	Values			Units
			Min.	Typ.	Max.	
$I_S$	Continuous Source Current (Body Diode)	TC=25 °C	--	--	9	A
$I_{SM}$	Maximum Pulsed Current (Body Diode)		--	--	36	A
$V_{SD}$	Diode Forward Voltage	IS=9A, VGS=0V(Note4)	--	--	1.2	V
$T_{rr}$	Reverse Recovery Time	IS=9A, Tj = 25°C dIF/dt=100A/us, VGS=0V	--	325	--	ns
$Q_{rr}$	Reverse Recovery Charge		--	1836	--	nC
$I_{rrm}$	Reverse Recovery Current		--	11.3	--	A

Note1: Pulse width limited by maximum junction temperature

Note2: L=20mH, VDs=50V, Start TJ=25°C

Note3: ISD =9A, di/dt ≤100A/us, VDD≤BVDS, Start TJ=25°C

Note4: Pulse width tp≤300μs, δ≤2%

**5. Characteristics Curves**

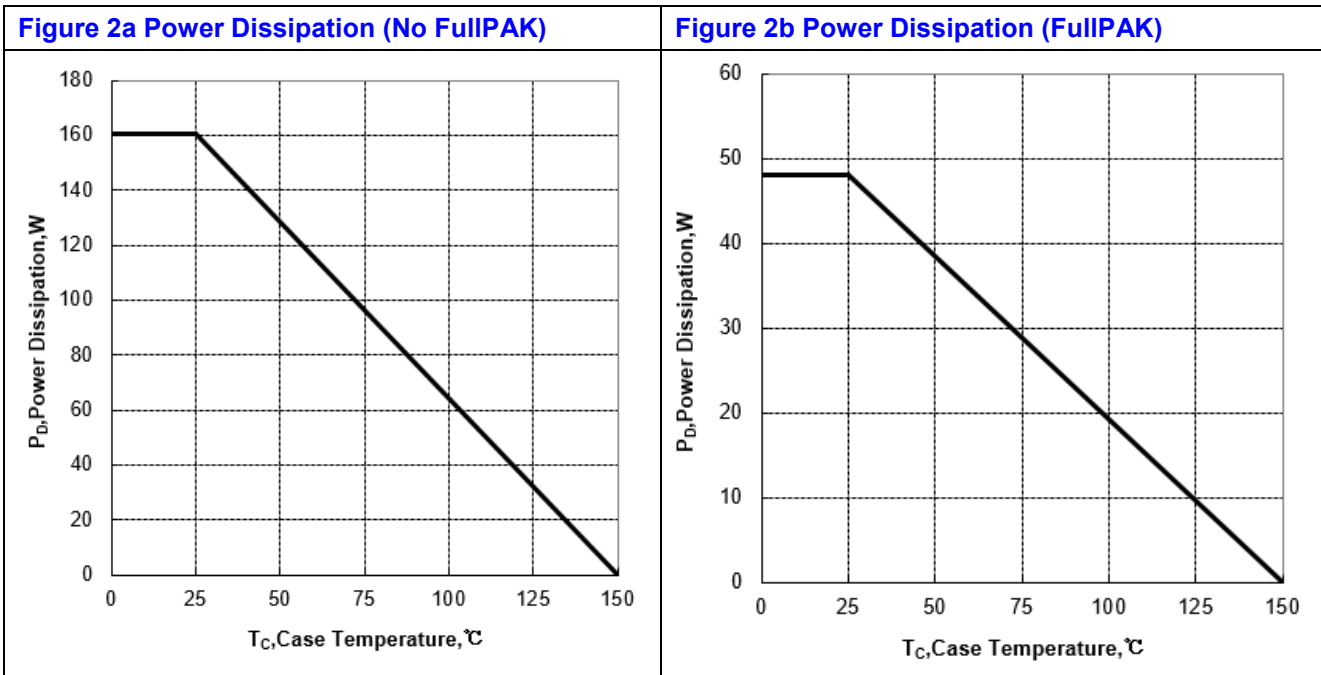
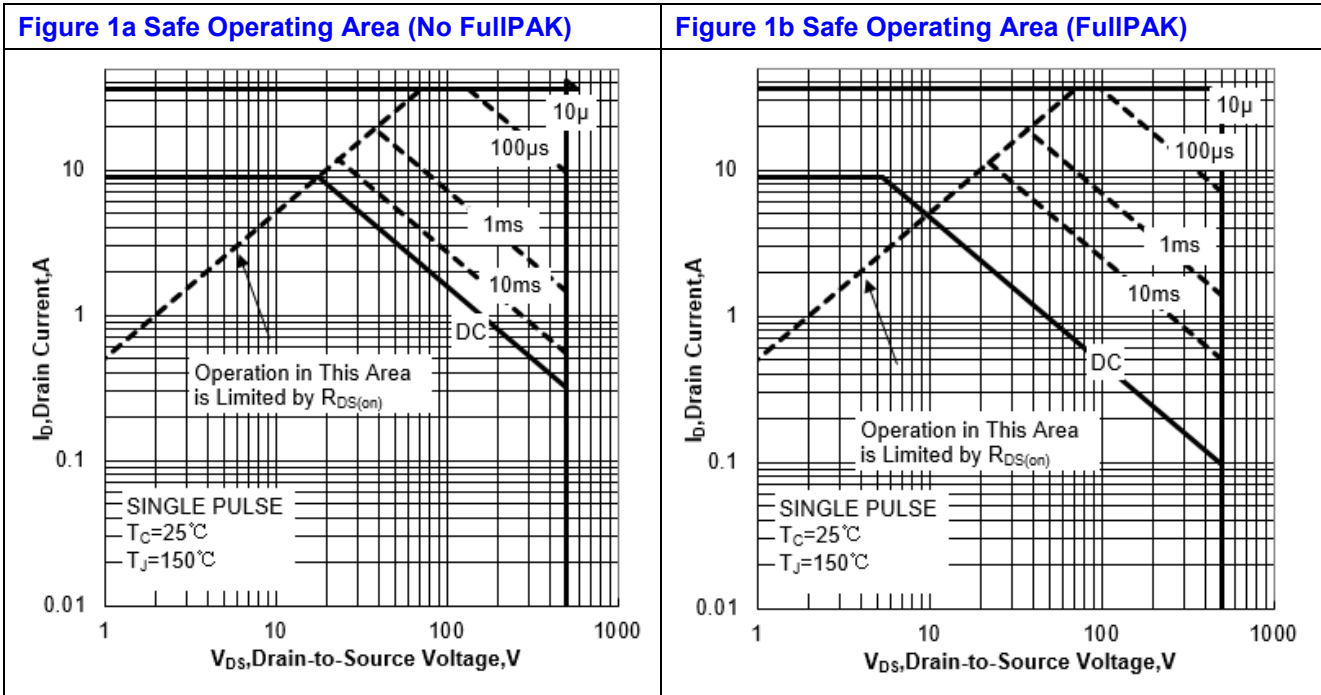

**Figure 3a Max Thermal Impedance (No FullPAK)**

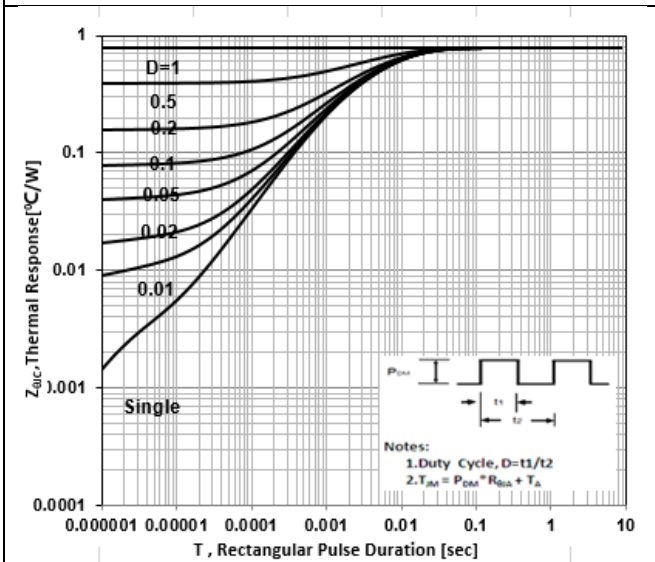

**Figure 3b Max Thermal Impedance (FullPAK)**

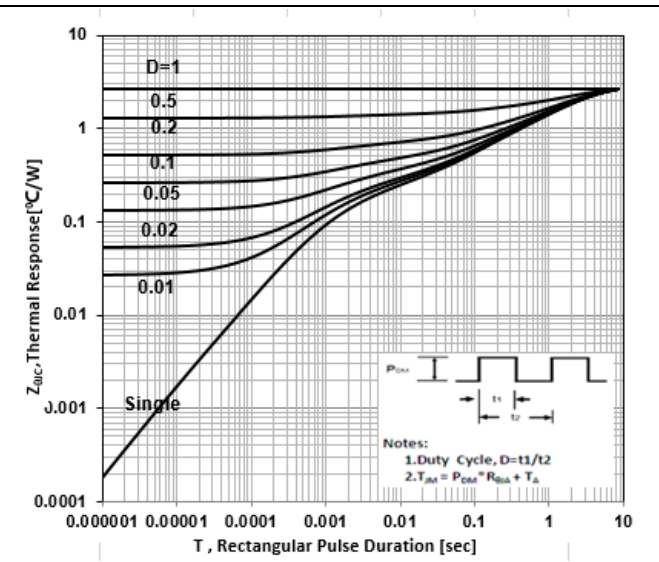

**Figure 4 Typical Output Characteristics**

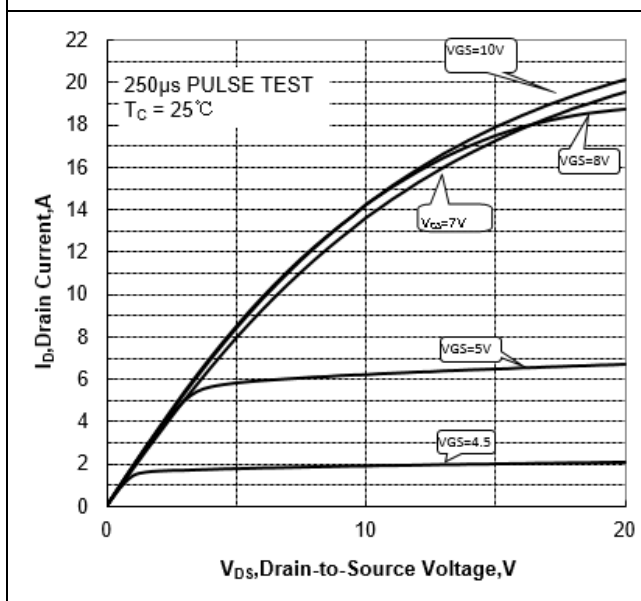

**Figure 5 Typical Transfer Characteristics**

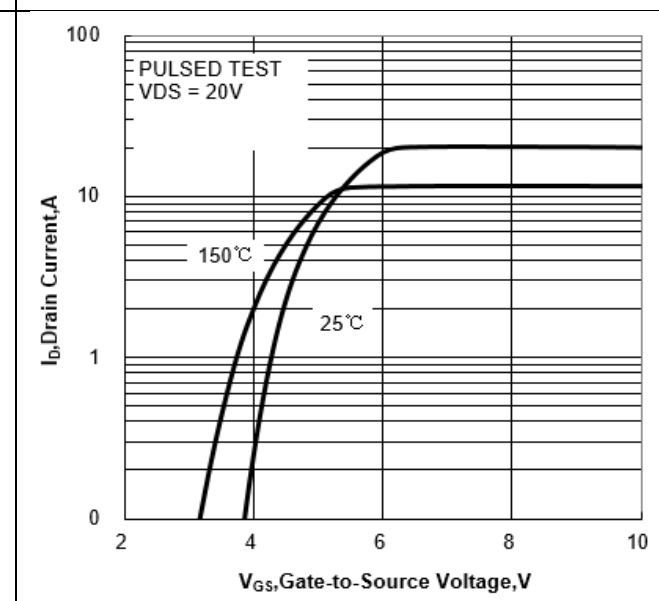

**Figure 6 Typical Drain to Source ON Resistance vs Drain Current**

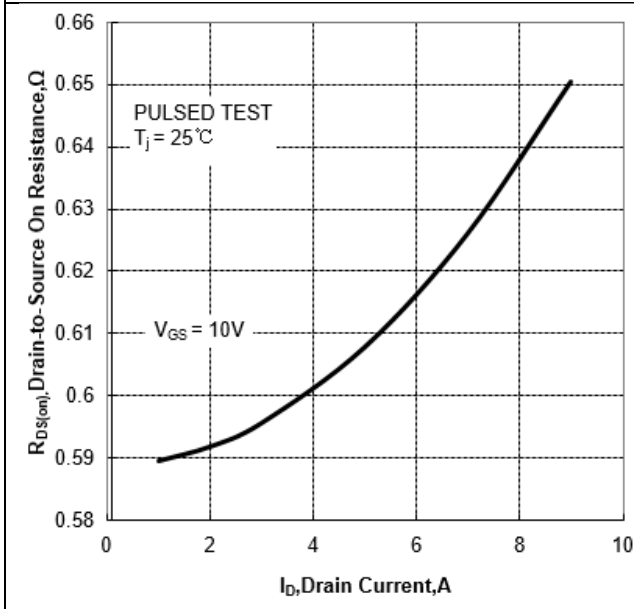

**Figure 7 Typical Drain to Source on Resistance vs Junction Temperature**

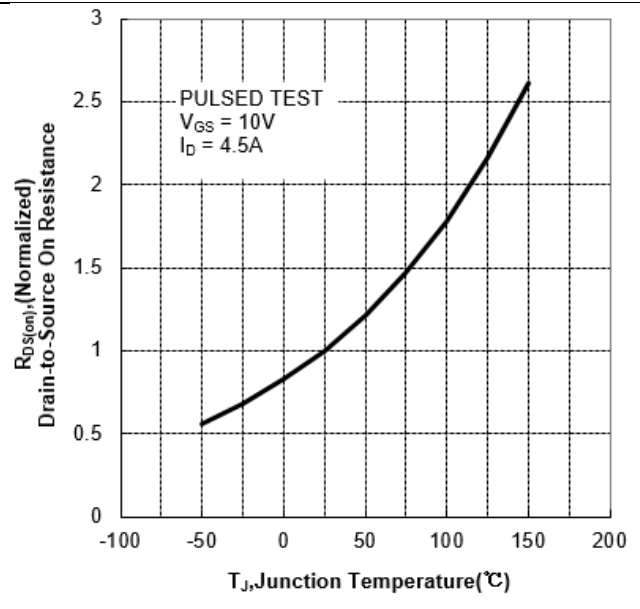

**Figure 8 Typical Theshold Voltage vs Junction Temperature**

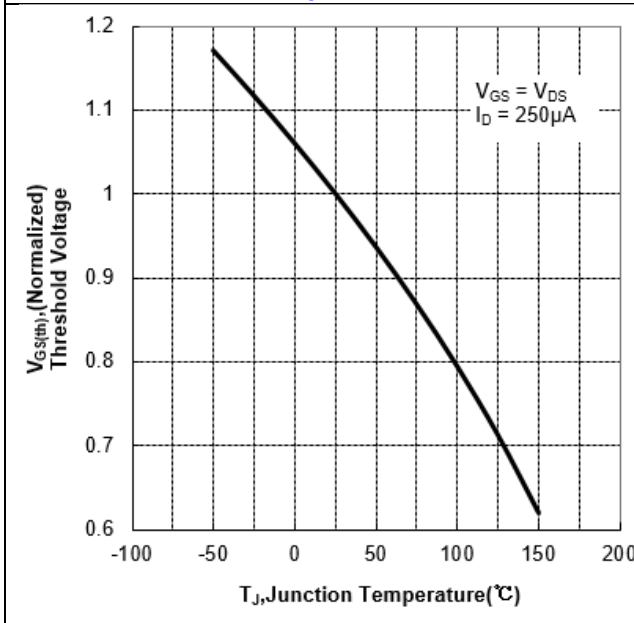

**Figure 9 Typical Breakdown Voltage vs Junction Temperature**

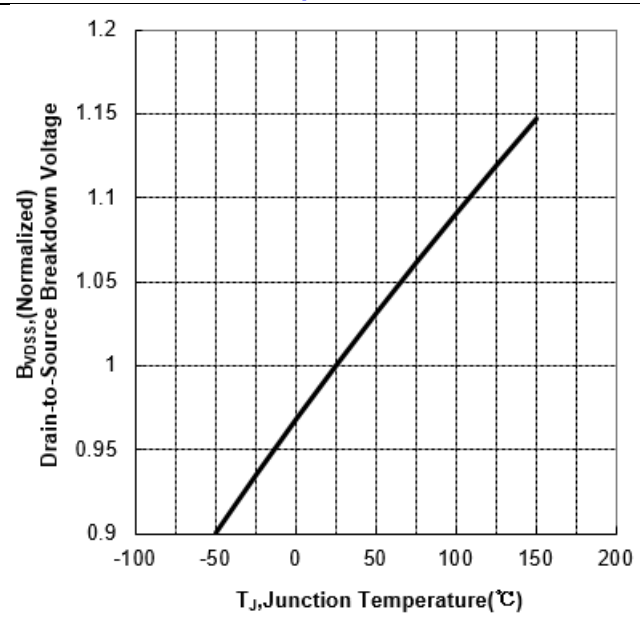

**Figure 10 Typical Capacitance vs Drain to Source Voltage**

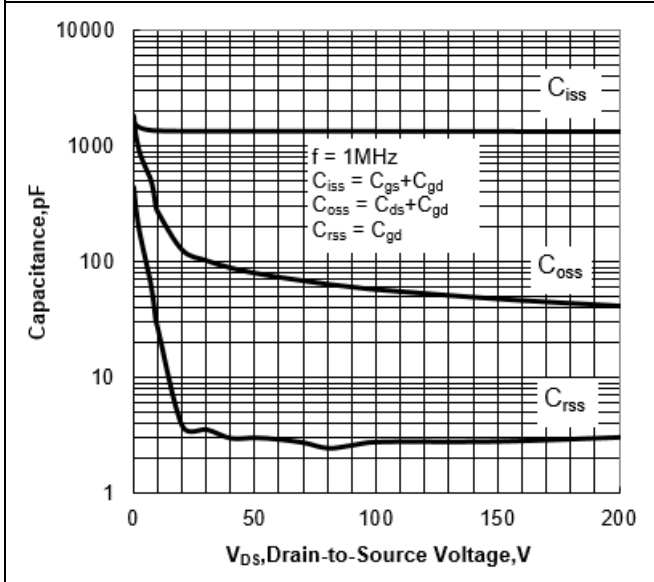

**Figure 11 Typical Gate Charge vs Gate to Source Voltage**

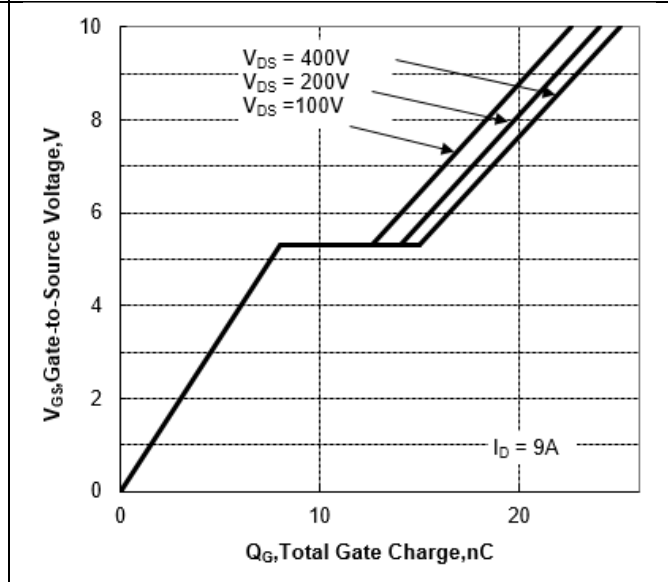



## 6. Test Circuit and Waveform

<p><b>Figure 12 Gate Charge Test Circuit</b></p>	<p><b>Figure 13 Gate Charge Waveforms</b></p>
<p><b>Figure 14 Resistive Switching Test Circuit</b></p>	<p><b>Figure 15 Resistive Switching Waveforms</b></p>

Figure 16 Diode Reverse Recovery Test Circuit

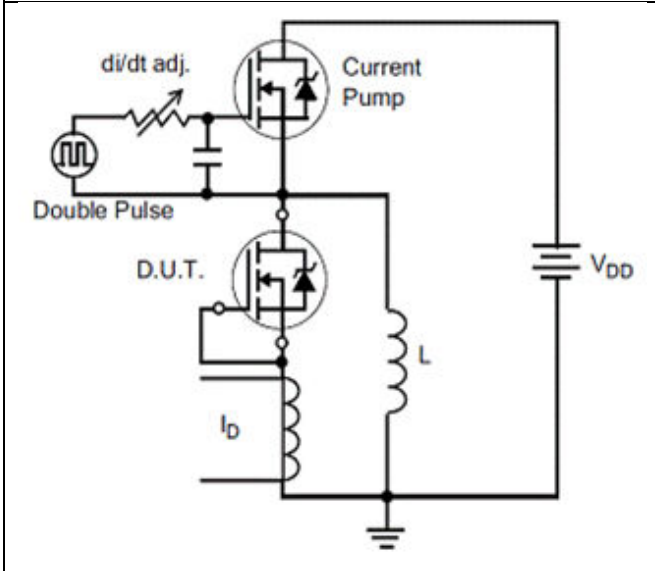

Figure 17 Diode Reverse Recovery Waveform

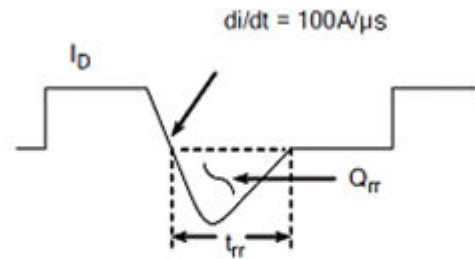

Figure 18 Unclamped Inductive Switching Test Circuit

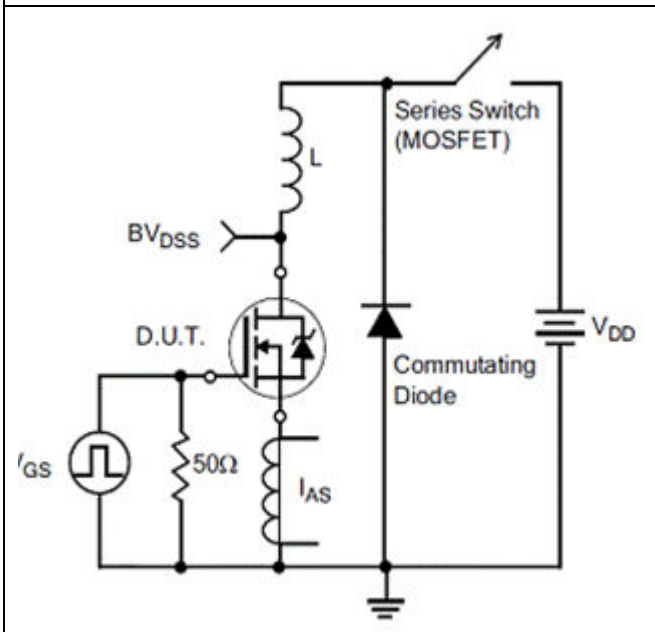
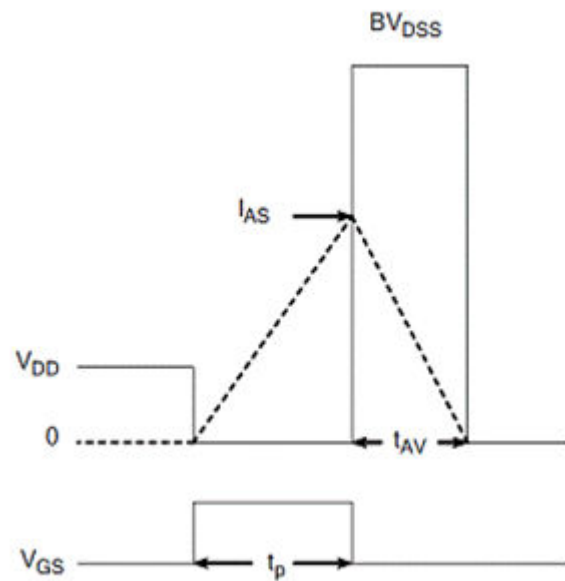
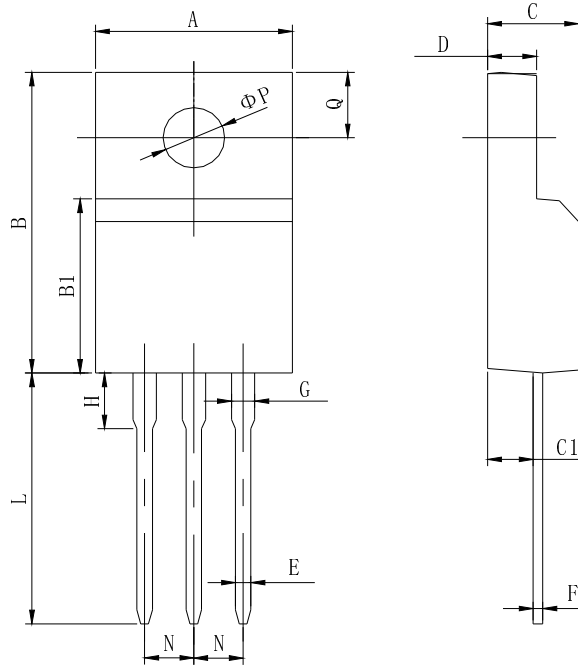

Figure 19 Unclamped Inductive Switching Waveform



## 7. Package Description



Items	Values(mm)	
	MIN	MAX
A	9.60	10.4
B	15.4	16.2
B1	8.90	9.50
C	4.30	4.90
C1	2.10	3.00
D	2.40	3.00
E	0.60	1.00
F	0.30	0.60
G	1.12	1.42
H	3.40	3.80
	1.60	2.90
L	12.0	14.0
N	2.34	2.74
Q	3.15	3.55
Φ P	2.90	3.30

TO-220F Package

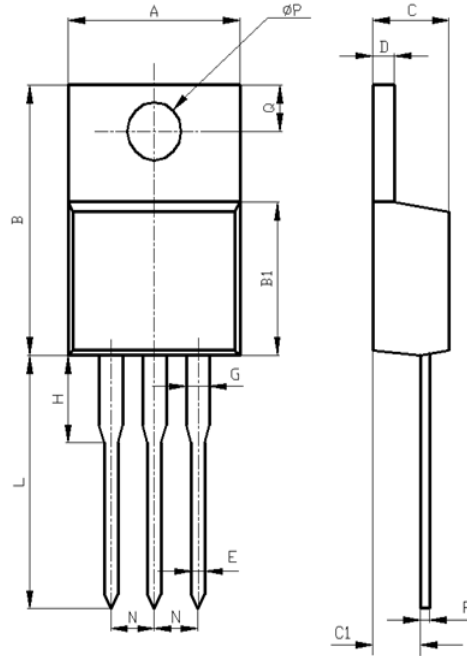

Items	Values(mm)	
	MIN	MAX
A	9.60	10.6
B	15.0	16.0
B1	8.90	9.50
C	4.30	4.80
C1	2.30	3.10
D	1.20	1.40
E	0.70	0.90
F	0.30	0.60
G	1.17	1.37
H	2.70	3.80
L	12.6	14.8
N	2.34	2.74
Q	2.40	3.00
φ P	3.50	3.90

TO-220 Package

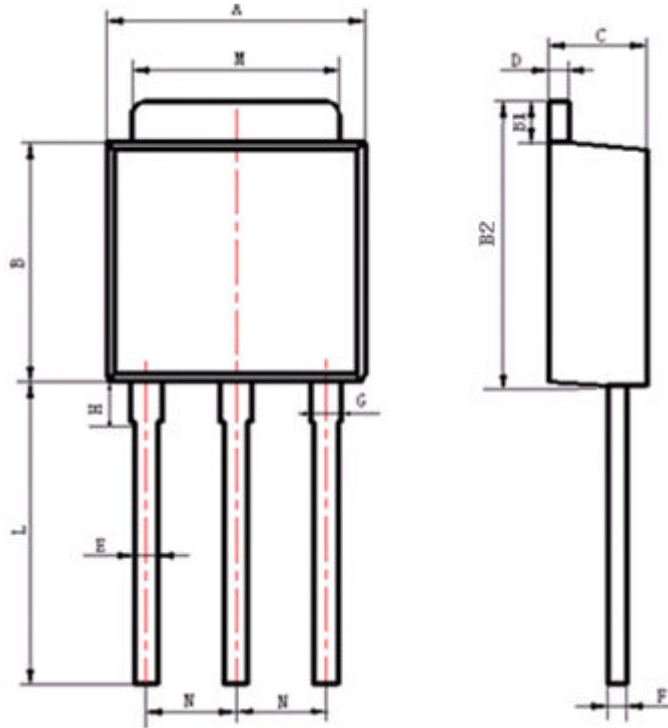

Items	Values(mm)	
	MIN	MAX
A	6.30	6.90
B	5.70	6.30
B1	1.00	1.20
B2	6.80	7.40
C	2.10	2.50
D	0.30	0.60
E	0.50	0.70
F	0.30	0.60
G	0.70	1.00
H	1.60	2.40
L*	3.9	4.3
M	5.10	5.50
N	2.09	2.49

\*: adjustable

TO-251 Package

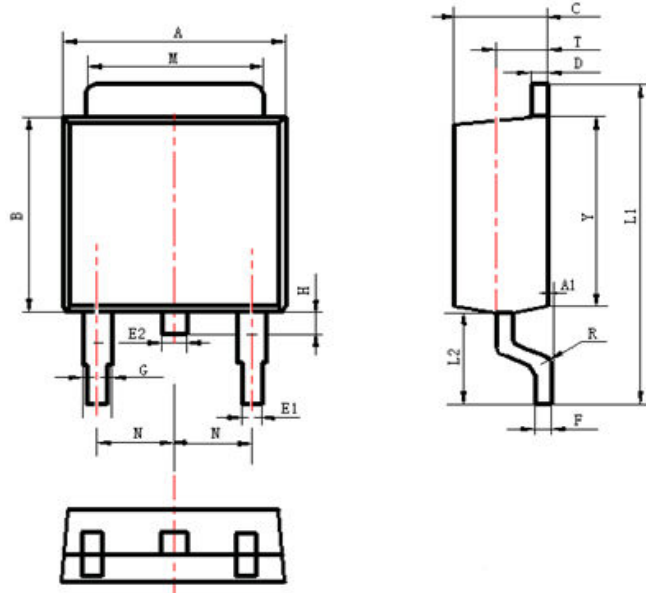

Items	Values(mm)	
	MIN	MAX
A	6.30	6.90
A1	0	0.13
B	5.70	6.30
C	2.10	2.50
D	0.30	0.60
E1	0.60	0.90
E2	0.70	1.00
F	0.30	0.60
G	0.70	1.20
L1	9.60	10.50
L2	2.70	3.10
H	0.60	1.00
M	5.10	5.50
N	2.09	2.49
R	0.3	
T	1.40	1.60
Y	5.10	6.30

TO-252 Package

## NOTE:

1. Exceeding the maximum ratings of the device in performance may cause damage to the device, even the permanent failure, which may affect the dependability of the machine. Please do not exceed the absolute maximum ratings of the device when circuit designing.
2. When installing the heat sink, please pay attention to the torsional moment and the smoothness of the heat sink.
3. MOSFETs is the device which is sensitive to the static electricity, it is necessary to protect the device from being damaged by the static electricity when using it.
4. Shanghai Belling reserves the right to make changes in this specification sheet and is subject to change without prior notice.

## CONTACT:

### 上海贝岭股份有限公司（总部）

地址：上海市宜山路 810 号

邮编：200233

电话：021-24261000

### 产品业务咨询及技术支持

电话：021-24261326

传真 2：021-64852222

邮箱 2：marketing@belling.com.cn

### 上海贝岭深圳分公司（华南区）

地址：深圳市福田区中心区民田路新华保险大厦 1510 室

邮编：518031

电话：0755-33336776 0755-33336770

传真：0755-33336788

### 上海贝岭北京办事处（华北区）

地址：北京市西城区新华里 16 号院锦官苑小区 10 号楼 1 单元 1505 室

邮编：100044

电话：010-64179374

传真：010-8835 9236