

ACCEL SPI BOARD™

Manual

All Mikroelektronika's development systems feature a large number of peripheral modules expanding microcontroller's range of application and making the process of program testing easier. In addition to these modules, it is also possible to use numerous additional modules linked to the development system through the I/O port connectors. Some of these additional modules can operate as stand-alone devices without being connected to the microcontroller.

Additional board

 **MikroElektronika**

SOFTWARE AND HARDWARE SOLUTIONS FOR EMBEDDED WORLD ...making it simple

ACCEL SPI BOARD

Accel SPI Board is used to measure acceleration and gravity. The measurement on the additional board is performed by using the ADXL345 accelerometer circuit. The additional board is connected to the microcontroller on the development board via pads and communicates with the microcontroller by using serial SPI interface.



Figure 1: *Accel SPI Board*

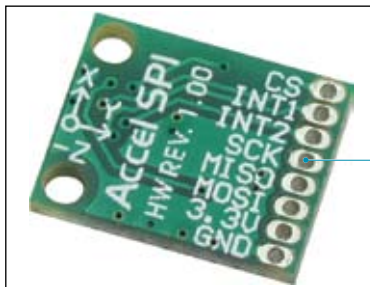

Figure 2: *Accel SPI Board's back side*

Eight pads for connecting the additional board to the microcontroller on the development system or to some device

Accel SPI Board is a low-power additional board, thus making it suitable for integrating into mobile devices. The additional board is used to measure dynamic and static acceleration in 13-bit resolution ranging +/- 16g.

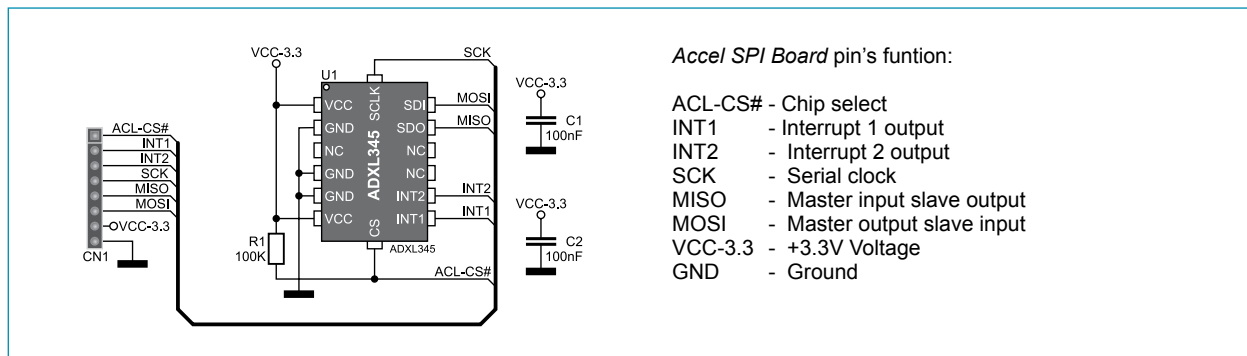

Figure 3: *Accel SPI Board* connection schematic

Mouser Electronics

Authorized Distributor

Click to View Pricing, Inventory, Delivery & Lifecycle Information:

[MikroElektronika:](#)

[MIKROE-473](#)