

251657216

**Product Data Sheet**

**9594314001**

VBS0120XUJCS

RER120-26/14/2TDP

**ebmpapst**

The engineer's choice



RER120-26/14/2TDP

INDEX

**1 General ..... 3**

**2 Mechanics ..... 3**

2.1 General..... 3

2.2 Connections..... 3

**3 Operating Data ..... 5**

3.1 Electrical Interface - Input..... 5

3.2 Electrical Operating Data ..... 6

3.3 Electrical Interface - Output..... 7

3.4 Electrical Features ..... 8

3.5 Aerodynamics ..... 9

3.6 Sound Data..... 10

**4 Environment..... 10**

4.1 General..... 10

4.2 Climatic Requirements ..... 10

**5 Safety..... 11**

5.1 Electrical Safety ..... 11

5.2 Approval Tests ..... 11

**6 Reliability..... 11**

6.1 General..... 11

## 1 General

Fan type	Blower without chassis with intake nozzle	
Rotating direction looking at rotor	Clockwise	
Airflow direction	Air in axially, Air out radially	
Bearing system	Ball bearing	
Mounting position - shaft	Any	

**Please note:**

"Sensorless commutation electronic, starting at the first start may not be 100% guaranteed, automatic restart occurs."

In order to achieve the specified life time figure, it is necessary to connect an external capacitor of 470uF/100V (e.g. Rubycon ZL100V/470uF; ebm-papst p/n 4132 xxx xxx) to the supply voltage between plus and minus. Max. lead length between fan and capacitor: 300 mm

## 2 Mechanics

### 2.1 General

Depth	54,0 mm	
Diameter	120,0 mm	
Mass	0,430 kg	
Housing material		
Impeller material	Plastic	

### 2.2 Connections

Electrical connection	Wires	
Lead wire length	L = 310 mm	
Tolerance	+/- 10,0 mm	
Tube length	S = 65 mm	
Tolerance	+/- 5,0 mm	

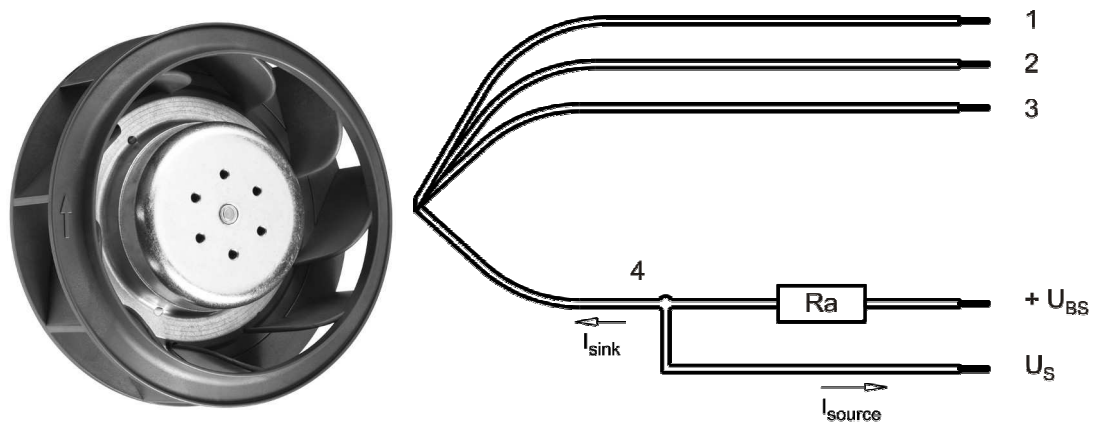

Wire	Color	Operation	Wire size	Insulation diameter
1	red	+ UB	AWG 20	2,05 mm
2	blue	- GND	AWG 20	2,05 mm
3	violet	PWM	AWG 22	1,3 mm
4	white	Tacho	AWG 22	1,3 mm

The auxiliaries shown on the schematic diagram (which are required for the intended use) are not part of our delivery.

3 Operating Data

3.1 Electrical Interface - Input

Control input	PWM
---------------	-----

Features

Input type	Open collector	
PWM - Frequency		1 kHz - 10 kHz typical: 2 kHz

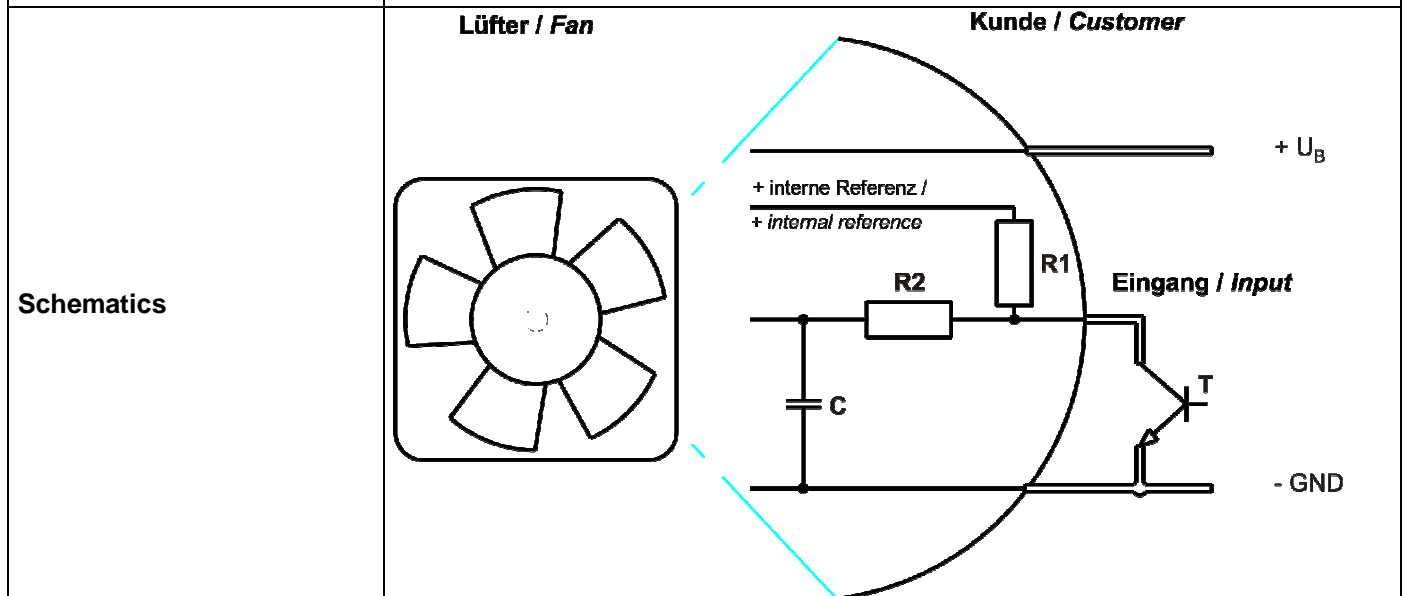
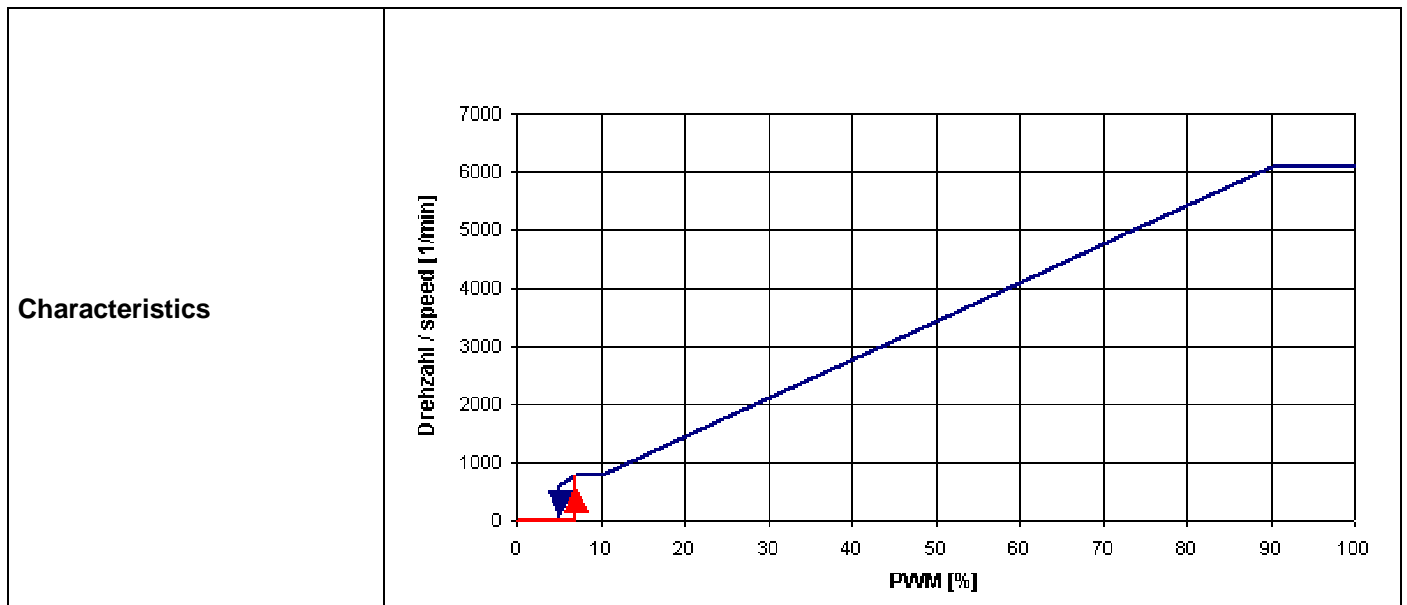

**Speed control:**

By Puls width modulation (PWM) 0 ... 100%

Open collector in relation to signal-ground

$f = 2\text{kHz} \pm 20\%$

**Information to the curve:**

0 % - 7% PWM:	0 1/min
7 % - 10% PWM:	800 1/min (corresponding to min. speed)
10 % - 90% PWM:	linear increasing curve
90 % - 100% PWM:	6.100 1/min (corresponding to max. speed)
7 % PWM:	800 1/min (Fan on, coming from 0% PWM)
5 % PWM:	600 1/min bzw. 0 1/min (Fan off, coming from 100% PWM)

### 3.2 Electrical Operating Data

Measurement conditions: Normal air density = 1,2 kg/m<sup>3</sup>; Temperature 23°C +/- 3°C; Motor axis horizontal; warm-up time before measuring 5 minutes (unless otherwise specified).

In the intake and outlet area should not be any solid obstruction within 0,5 m.

Measurement setup:	Measured between two steel plates
Steel plate:	140 mm x 140 mm
Intake nozzle:	D: 96 mm; R: 16 mm
Distance between bottom and top plate:	70 mm
Overlapping impeller / nozzle:	2 mm

$\Delta p = 0$ : corresp. to free air flow (see chapter aerodynamics)

I: corresp. to arithm. mean current value

Name	Condition
PWM 0001	PWM: 100 %; f: 2 kHz

**100% PWM; f = 2 kHz or broken lead wire (open control input)**

Features	Condition	Symbol	Values		
Voltage range		U	16 V		32 V
Nominal voltage		$U_N$		24 V	
Power consumption	$\Delta p = 0$	P	72 W	96 W	96 W
Tolerance	PWM 0010		+/- 10 %	+/- 10 %	+/- 10 %
Current consumption	$\Delta p = 0$	I	4.500 mA	4.000 mA	3.000 mA
Tolerance	PWM0010		+/- 10 %	+/- 10 %	+/- 10 %
Speed	$\Delta p = 0$	n	5.600 1/min	6.100 1/min	6.100 1/min
Tolerance	PWM 0010		+/- 7,5 %	+/- 7,5 %	+/- 7,5 %

3.3 Electrical Interface - Output

Tacho type	/2 (open collector)
------------	---------------------

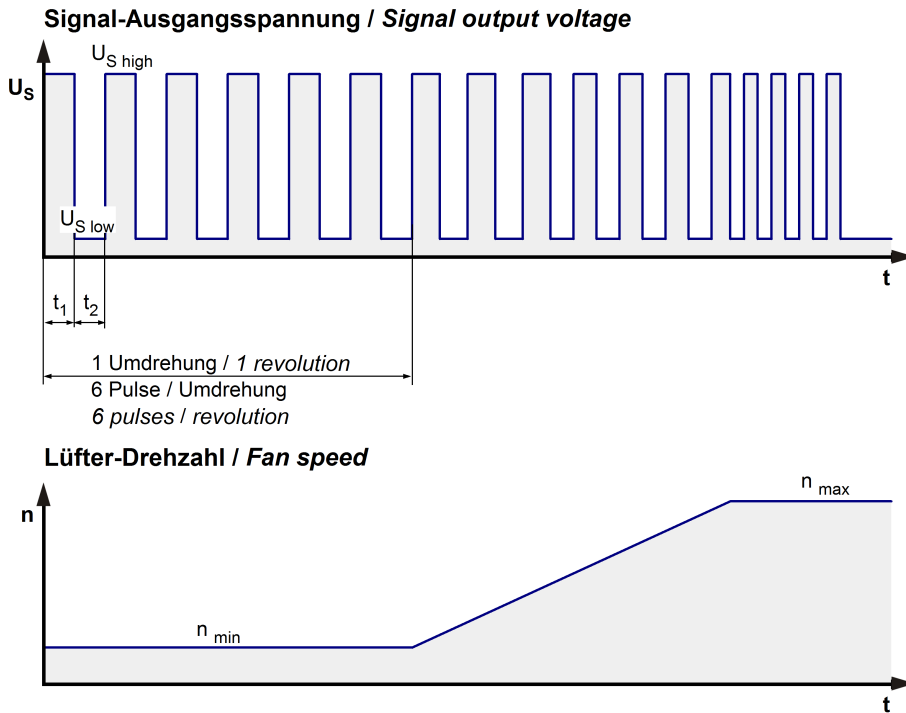

$$R_a = \frac{U_{BS} - U_{S\ low}}{I_{sink}}$$

Lüfter / Fan      Kunde / Customer

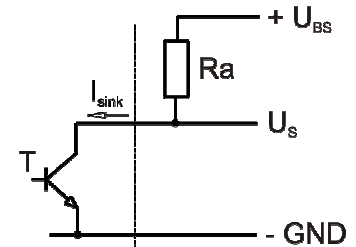

Features	Note	Values
Tacho operating voltage	$U_{BS}$	$\leq 32,0\ V$
Tacho signal Low	$U_{S\ low}$	$\leq 0,4\ V$
Tacho signal High	$U_{S\ high}$	$\leq 32,0\ V$
Maximum sink current	$I_{sink}$	$\leq 20\ mA$
Maximum source current		$0\ mA$
External resistor	External resistor $R_a$ from $U_{BS}$ to $U_s$ required. All voltages measured to GND.	
Tacho frequency	$(6 \times n) / 60$	610 Hz
Tacho isolated from motor	No	
Slew rate		$\Rightarrow 0,5\ V/\mu s$

$n$  = revolutions per minute (1/min)

**Please note:**

At zero speed the tacho signal is at a static HIGH. It will be also HIGH when the fan is still spinning, but the speed control signal is set to zero speed already.

The tacho signal is only activated after the start-up is completed.

### 3.4 Electrical Features

Electronic function	Speed-Controlled	
Reversed polarity protection	N-CH FET	
Max. residual current at $U_N$	$I_F \leq 5 \text{ mA}$	
Locked rotor protection	Auto restart	
Locked rotor current at $U_N$	$I_{\text{block}}$ approx. 2.000 mA	
Clock signal at locked rotor	$t_3 / t_4$ typical: 4,5 s / 10,0 s	

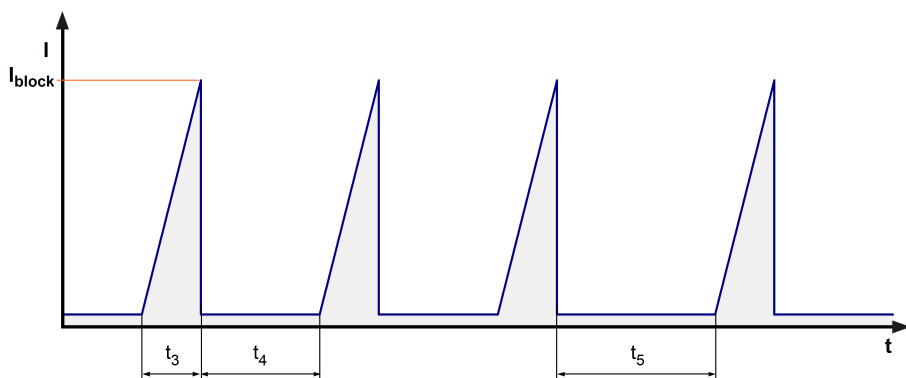

#### Locked rotor signal $t_5$ :

After 4 failed start-ups there is an extended timeout of 40 s.



### 3.5 Aerodynamics

Measurement conditions: Measured with a double chamber intake rig acc. to DIN EN ISO 5801. Normal air density = 1,2 kg/m<sup>3</sup>; Temperature 23°C +/- 3°C; In the intake and outlet area should not be any solid obstruction within 0,5 m. Motor shaft horizontal. The information is only valid under the specified test conditions and may be changed by the installation conditions. If there are deviations from the standard test conditions, the characteristic values must be checked under the installed conditions. Power consumption of the fan motor when operating at normal voltage is shown. Depending on the operating conditions of the application, the power input may be higher.

Measurement setup:	Measured between two steel plates
Steel plate:	140 mm x 140 mm
Intake nozzle:	D: 96 mm; R: 16 mm
Distance between bottom and top plate:	70 mm
Overlapping impeller / nozzle:	2 mm

a.) Operation condition:

6.100 1/min at free air flow	PWM 100 %; f: 2 kHz		
------------------------------	---------------------	--	--

Max. free-air flow ( $\Delta p = 0 / \dot{V} = \text{max.}$ )	375,0 m <sup>3</sup> /h	
Max. static pressure ( $\Delta p = \text{max.} / \dot{V} = 0$ )	558 Pa	

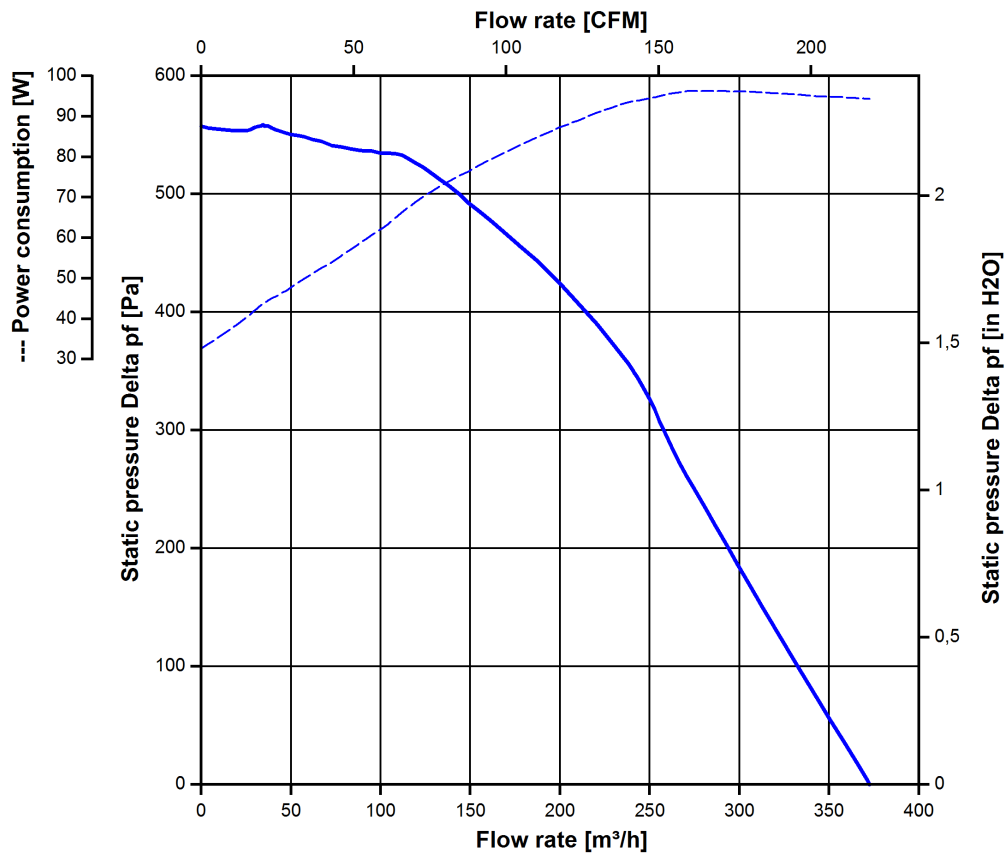

### 3.6 Sound Data

Measurement conditions: Sound pressure level: 1 meter distance between microphone and the air intake.  
Sound power level: Acc. to DIN 45635 part 38 (ISO 10302)  
Measured in a semianchoic chamber with a background noise level of  $L_p(A) < 5 \text{ dB(A)}$   
For further measurement conditions see chapter aerodynamics.

a.) Operation condition:

6.100 1/min at free air flow	PWM 100 %; f: 2 kHz		
------------------------------	---------------------	--	--

Optimal operating point	50,0 m <sup>3</sup> /h @ 511 Pa		
Sound power level at the optimal operating point	8,2 bel(A)		
Sound pressure level at free air flow, measured in rubber bands			

## 4 Environment

### 4.1 General

Min. permitted ambient temperature TU min.	-20 °C		
Max. permitted ambient temperature TU max.	60 °C		
Min. permitted storage temperature TL min.	-40 °C		
Max. permitted storage temperature TL max.	80 °C		

### 4.2 Climatic Requirements

Humidity requirements	humid heat, constant; according to DIN EN 60068-2-78, 14 days		
Water exposure	None		
Dust requirements	None		
Salt fog requirements	None		

Permitted application area:

The product is intended for use in sheltered rooms with controlled temperature and controlled humidity. Directly exposure to water must be avoided.

Pollution degree 1 (according DIN EN 60664-1)

There is either no pollution or it occurs only dry, non-conductive pollution. The pollution has no negative impact.

Please require severity levels and specification parameters from the responsible development departments.

**5 Safety****5.1 Electrical Safety**

Dielectric strength DIN EN 62368 and DIN EN 60335 A.) Type test Measuring conditions: After 48h of storage at 95% R.H. and 25°C. No arcing or breakdown is allowed! All connections together to ground. B.) Routine test Measuring conditions: At indoor climate. No arcing or breakdown is allowed! All connections together to ground.	500 VAC / 1 Min.  850 VDC / 1 Sec.	
Isolation resistance Measuring conditions: After 48h of storage at 95% R.H. and 25°C measured with U=500 VDC for 1 min.	RI > 10 MOhm	
Clearance / creepage distance	1,0 mm / 1,2 mm	
Protection class	III	

**5.2 Approval Tests**

CE	EC Declaration of Conformity	Yes
EAC	Eurasian Conformity	Yes
UL	Underwriters Laboratories	Yes / UL507, Electric Fans E38324
VDE	Association for Electrical, Electronic and Information Technologies	Yes / Approval acc. to EN 62368 - Audio/video, information and communication technology equipment
CSA	Canadian Standards Association	Yes / C22.2 No. 113 Fans and Ventilators
CCC	China Compulsory Certification	Not applicable

The approval tests are observed to:

U approval max.: 32,0 V @ TU approval max.: 60,0 °C

**6 Reliability****6.1 General**

Life expectancy L10 at TU = 40 °C	55.000 h	
Life expectancy L10 at TU max.	35.000 h	
Life expectancy L10 acc. to IPC 9591 at TU = 40 °C	92.5 00 h	

