

CG2H40120

120 W, 28 V, RF Power GaN HEMT

Description

The CG2H40120 is an unmatched, gallium nitride (GaN) high electron mobility transistor (HEMT). The CG2H40120, operating from a 28 volt rail, offers a general purpose, broadband solution to a variety of RF and microwave applications. GaN HEMTs offer high efficiency, high gain and wide bandwidth capabilities making the CG2H40120 ideal for linear and compressed amplifier circuits. The transistor is available in a flange and pill package.

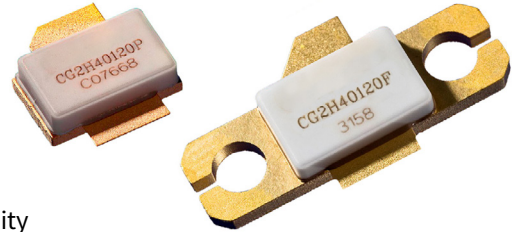

Package Types: 440206 and 440223
PNs: CG2H40120P and CG2H40120F

Features

- Up to 2.5 GHz Operation
- 20 dB Small Signal Gain at 1.0 GHz
- 15 dB Small Signal Gain at 2.0 GHz
- 130 W Typical P_{SAT}
- 70% Efficiency at P_{SAT}
- 28 V Operation

Applications

- 2-Way Private Radio
- Broadband Amplifiers
- Test Instrumentation



Large Signal Models Available for ADS and MWO



Absolute Maximum Ratings (not simultaneous) at 25°C Case Temperature

Parameter	Symbol	Rating	Units	Conditions
Drain-Source Voltage	V_{DSS}	120	V	25°C
Gate-to-Source Voltage	V_{GS}	-10, +2		
Storage Temperature	T_{STG}	-65, +150	°C	
Operating Junction Temperature	T_J	225		
Maximum Forward Gate Current	I_{GMAX}	30	mA	25°C
Maximum Drain Current ¹	I_{DMAX}	12	A	
Soldering Temperature ²	T_S	245	°C	
Screw Torque	τ	40	in-oz	
Thermal Resistance, Junction to Case ³	$R_{\theta JC}$	1.39	°C/W	85°C
Thermal Resistance, Junction to Case ⁴		1.32		
Case Operating Temperature ⁵	T_C	-40, +65	°C	

Notes:

¹ Current limit for long term, reliable operation

² Refer to the Application Note on soldering

³ Measured for the CG2H40120F at $P_{DISS} = 115$ W

⁴ Measured for the CG2H40120P at $P_{DISS} = 115$ W

⁵ See also, the Power Dissipation De-rating Curve on Page 5

Electrical Characteristics ($T_C = 25^\circ\text{C}$)

Parameter	Symbol	Min.	Typ.	Max.	Units	Conditions
DC Characteristics¹						
Gate Threshold Voltage	$V_{GS(th)}$	-3.8	-3.0	-2.3	V_{DC}	$V_{DS} = 10$ V, $I_D = 28.8$ mA
Gate Quiescent Voltage	$V_{GS(Q)}$	—	-2.7	—		$V_{DS} = 28$ V, $I_D = 1.0$ A
Saturated Drain Current ²	I_{DS}	20.7	28.2	—	A	$V_{DS} = 6.0$ V, $V_{GS} = 2.0$ V
Drain-Source Breakdown Voltage	V_{BR}	84	—	—	V_{DC}	$V_{GS} = -8$ V, $I_D = 28.8$ mA
RF Characteristics³ ($T_C = 25^\circ\text{C}$, $F_0 = 1.3$ GHz unless otherwise noted)						
Small Signal Gain	G_{SS}	18.5	20	—	dB	$V_{DD} = 28$ V, $I_{DQ} = 1.0$ A
Power Output ⁴	P_{SAT}	100	130	—	W	
Drain Efficiency ⁵	η	62	72	—	%	$V_{DD} = 28$ V, $I_{DQ} = 1.0$ A, $P_{OUT} = P_{SAT}$
Output Mismatch Stress	VSWR	—	—	10 : 1	Y	No damage at all phase angles, $V_{DD} = 28$ V, $I_{DQ} = 1.0$ A, $P_{OUT} = 100$ W CW
Dynamic Characteristics						
Input Capacitance	C_{GS}	—	35.7	—	pF	$V_{DS} = 28$ V, $V_{GS} = -8$ V, $f = 1$ MHz
Output Capacitance	C_{DS}	—	15.1	—		
Feedback Capacitance	C_{GD}	—	1.5	—		

Notes:

¹ Measured on wafer prior to packaging

² Scaled from PCM data

³ Measured in CG2H40120F/P-AMP

⁴ P_{SAT} is defined as $I_G = 2.8$ mA

⁵ Drain Efficiency = P_{OUT} / P_{DC}

Typical Performance

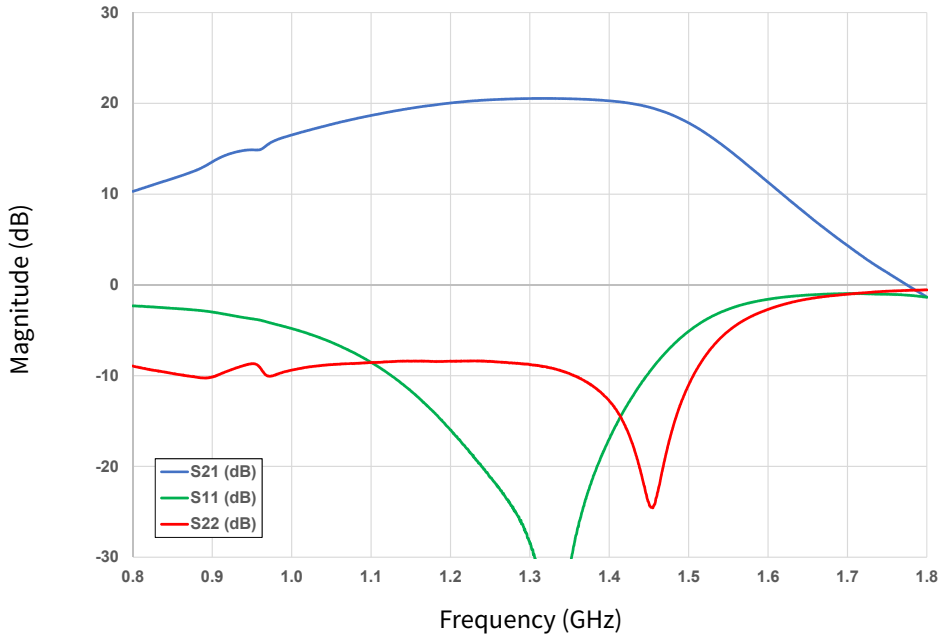

Figure 1. Gain and Input Return Loss vs Frequency measured in Broadband Amplifier Circuit CG2H40120F/P-AMP
 $V_{DD} = 28\text{ V}$, $I_{DQ} = 1.0\text{ A}$

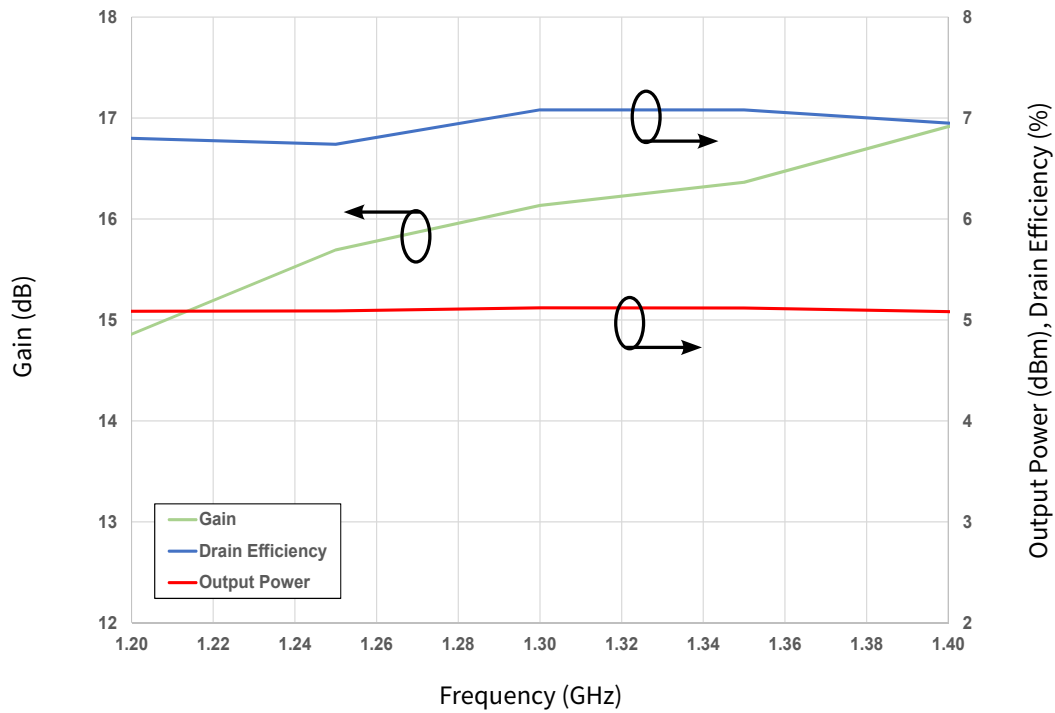

Figure 2. Saturated Output Power, Gain and Drain Efficiency vs Frequency measured in Broadband Amplifier Circuit CG2H40120F/P-AMP
 $V_{DD} = 28\text{ V}$, $I_{DQ} = 1.0\text{ A}$

Typical Performance

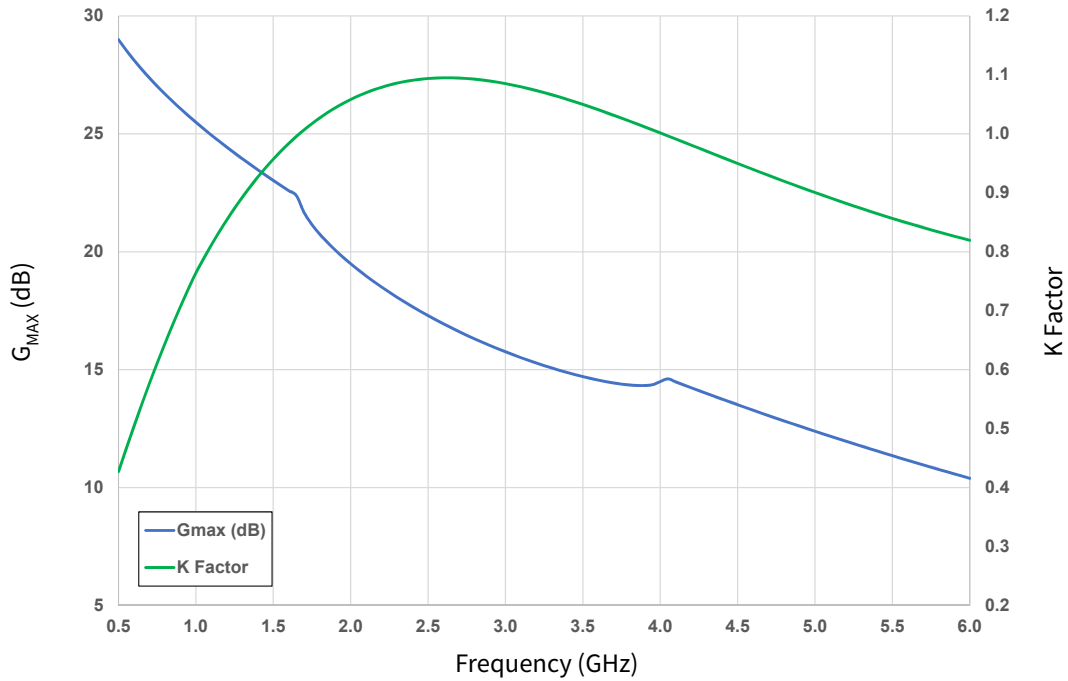

Figure 3. Simulated Maximum Available Gain and K Factor vs Frequency
Broadband Amplifier Circuit CG2H40120F/P-AMP

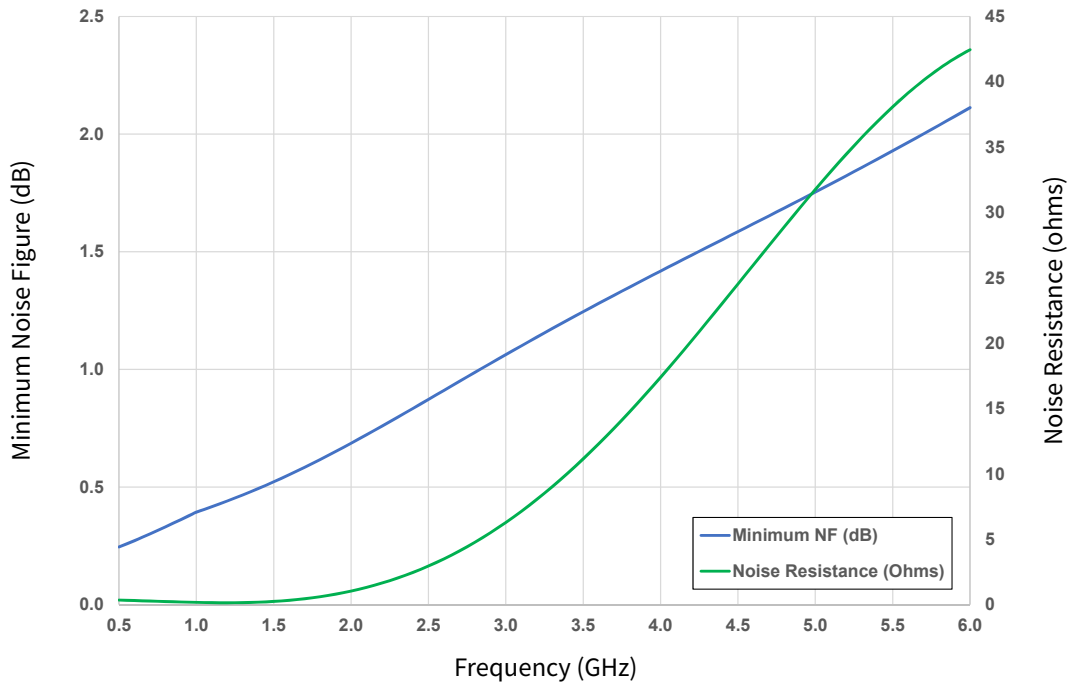

Figure 4. Simulated Minimum Noise and Noise Resistance vs Frequency
Broadband Amplifier Circuit CG2H40120F/P-AMP

Typical Performance

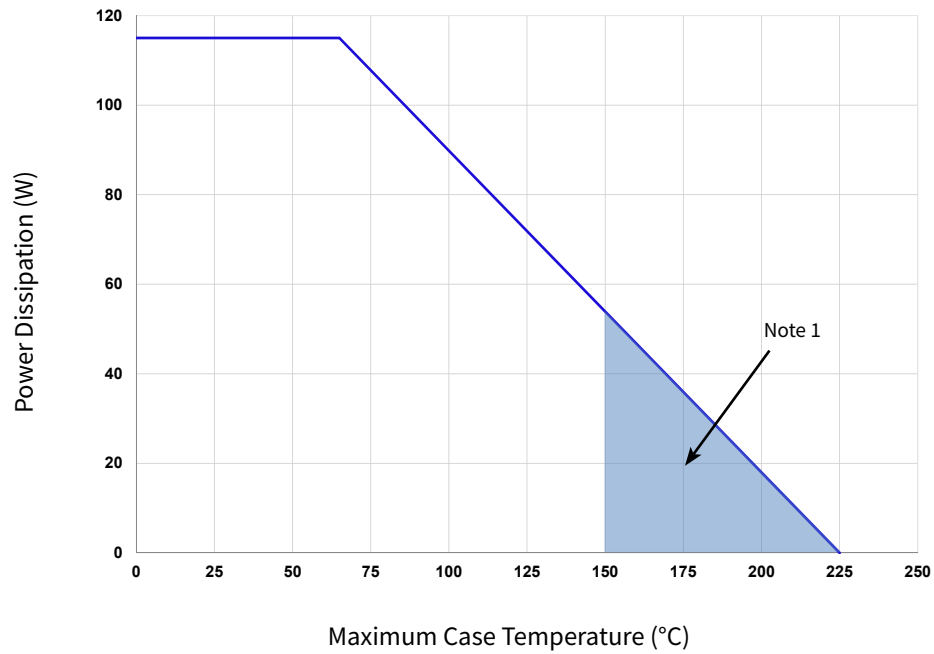
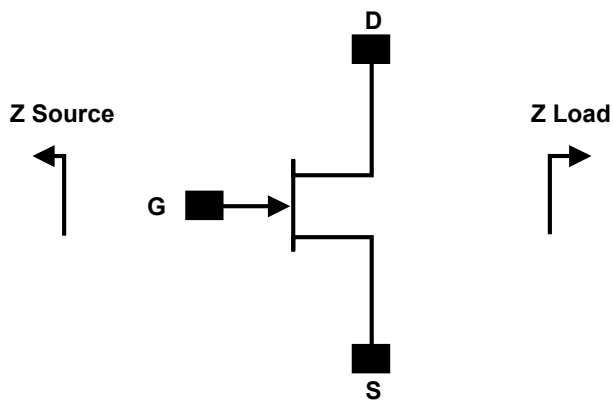

Figure 5. CG2H40120 CW Power Dissipation De-Rating Curve

Note:

¹ Area exceeds Maximum Case Operating Temperature (See Page 2).

Source and Load Impedances



Frequency (MHz)	Z Source	Z Load
500	1.73 + j0.34	4.25 - j1.43
1000	1.65 - j3.12	4.50 - j1.87
1500	1.63 - j3.50	2.58 - j3.26
2000	1.67 - j5.58	2.62 - j4.81
2500	2.00 - j4.92	4.25 - j6.43
3000	2.24 - j8.63	3.10 - j8.82

Notes:

¹ $V_{DD} = 28\text{ V}$, $I_{DQ} = 1.0\text{ A}$ in the 440223/440206 package

² Optimized for power gain, P_{SAT} and PAE

³ When using this device at low frequency, series resistors should be used to maintain amplifier stability

CG2H40120-AMP Demonstration Amplifier Circuit Bill of Materials

Designator	Description	Qty
R2	RES, 1/16W, 0603, 1%, 5.1 ohms	1
R1	RES, 1/16W, 0603, 1%, 511 ohms	1
C13, C33	CAP, 470pF, 5%, 100V, 0603	2
C36	CAP, 33μF, 20%, G CASE	1
C35	CAP, 1.0μF, 100V, 10%, X7R	1
C15	CAP, 10μF, 16V, TANTALUM	1
C12, C32	CAP, 100.0pF, 5%, 0603, ATC	2
C2	CAP, 1.2pF, 0.1pF, 0603, ATC	1
C11, C31	CAP, 27pF, 5%, 0603, ATC	2
C3, C4	CAP, 3.9pF, 0.1pF, 0603, AT	2
C5, C6	CAP, 4.7pF, 0.1pF, 0603, AT	2
C14, C34	CAP, 33000pF, 0805, 100V, X7R	2
C22, C23	CAP, 0.5pF, 0.05pF, 0805,	2
C24, C25	CAP, 1.2pF, 0.1pF, 0805	2
C1, C30	CAP, 27pF, 5%, 250V, 0805	2
C20, C21	CAP, 5.6pF, 0.1pF, 0805, A	2
1	PCB, RO4003, 0.032 THK, CGH40120F	1
	BASEPLATE, CGH35120	1
J1, J2	CONN, SMA, PANEL MOUNT JACK	2
J3	HEADER RT>PLZ .1CEN LK 9POS	1
L2	IND, FERRITE, 220 ohm, 0805	1
L1	INDUCTOR, CHIP, 6.8nH, 0603 SMT	1
	2-56 SOC HD SCREW ¼ SS	4
	#2 SPLIT LOCKWASHER SS	4
W1	WIRE, BLACK, 22 AWG ~ 2.0"	1
Q1	CG2H40120F	1

Electrostatic Discharge (ESD) Classifications

Parameter	Symbol	Class	Classification Level	Test Methodology
Human Body Model	HBM	1A	ANSI/ESDA/JEDEC JS-001 Table 3	JEDEC JESD22 A114-D
Charge Device Model	CDM	C3	ANSI/ESDA/JEDEC JS-002 Table 3	JEDEC JESD22 C101-C

CGH40120F-AMP Demonstration Amplifier Circuit Schematic

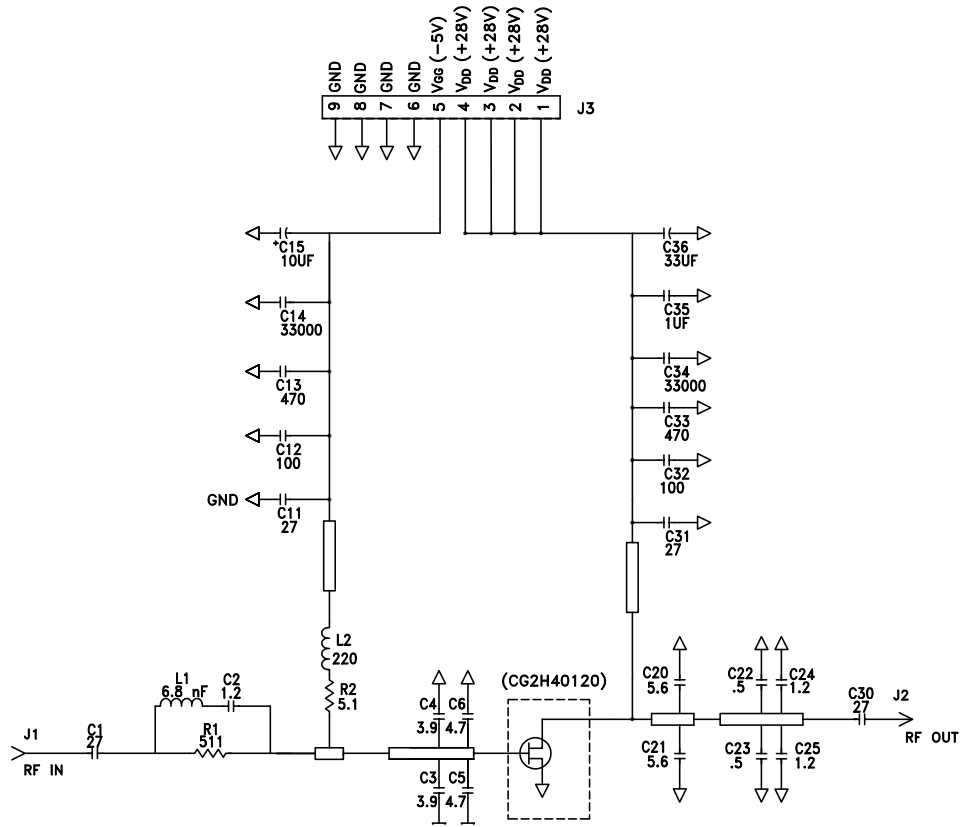

CGH40120F-AMP Demonstration Amplifier Circuit Outline

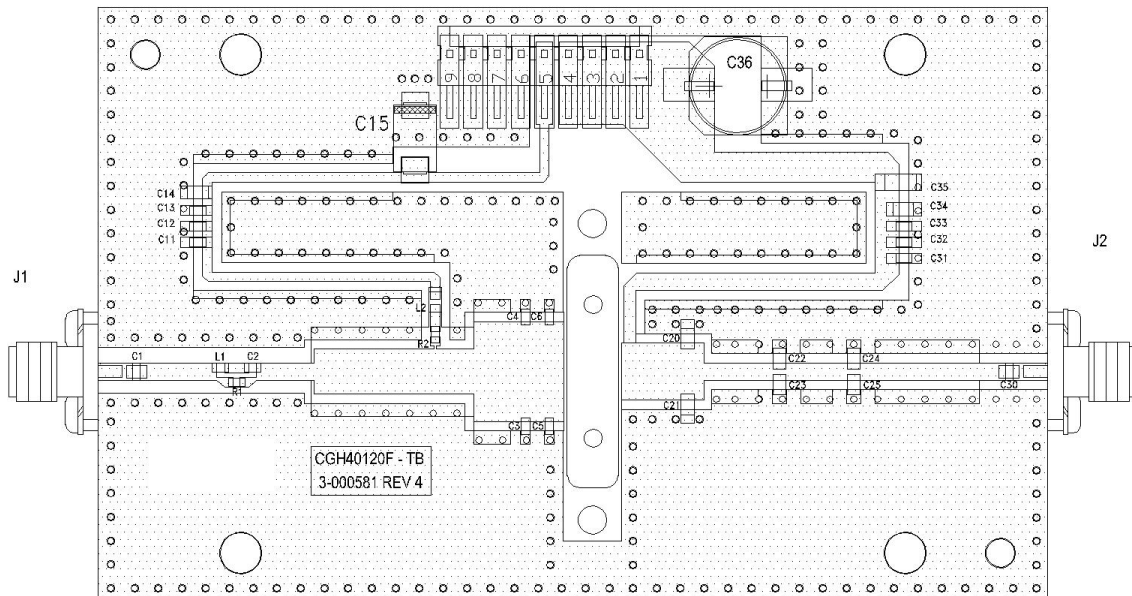

Typical Package S-Parameters for CG2H40120
(Small Signal, $V_{DS} = 28\text{ V}$, $I_{DQ} = 1.0\text{ A}$, angle in degrees)

Frequency	Mag S11	Ang S11	Mag S21	Ang S21	Mag S12	Ang S12	Mag S22	Ang S22
500 MHz	0.953	-179.24	5.30	79.16	0.007	11.58	0.848	178.11
600 MHz	0.953	179.13	4.42	76.14	0.007	12.91	0.848	177.31
700 MHz	0.952	177.74	3.80	73.25	0.007	14.29	0.849	176.55
800 MHz	0.952	176.49	3.33	70.44	0.007	15.67	0.849	175.84
900 MHz	0.952	175.33	2.97	67.69	0.007	17.01	0.849	175.14
1.0 GHz	0.951	174.25	2.68	64.99	0.007	18.29	0.849	174.46
1.1 GHz	0.951	173.20	2.44	62.32	0.008	19.51	0.850	173.78
1.2 GHz	0.950	172.19	2.25	59.68	0.008	20.65	0.850	173.10
1.3 GHz	0.950	171.21	2.09	57.08	0.008	21.71	0.851	172.43
1.4 GHz	0.949	170.24	1.95	54.51	0.008	22.68	0.851	171.76
1.5 GHz	0.948	169.28	1.83	51.95	0.009	23.55	0.851	171.08
1.6 GHz	0.947	168.33	1.73	49.41	0.009	24.33	0.850	170.41
1.7 GHz	0.946	167.38	1.64	46.88	0.010	25.00	0.850	169.72
1.8 GHz	0.945	166.42	1.57	44.36	0.010	25.57	0.849	169.03
1.9 GHz	0.943	165.45	1.51	41.84	0.011	26.03	0.848	168.32
2.0 GHz	0.941	164.47	1.45	39.33	0.011	26.38	0.847	167.61
2.1 GHz	0.940	163.48	1.40	36.80	0.012	26.61	0.846	166.88
2.2 GHz	0.937	162.46	1.36	34.27	0.012	26.74	0.844	166.14
2.3 GHz	0.935	161.41	1.33	31.72	0.013	26.75	0.842	165.38
2.4 GHz	0.932	160.34	1.30	29.16	0.014	26.65	0.840	164.60
2.5 GHz	0.929	159.23	1.27	26.58	0.015	26.43	0.837	163.80
2.6 GHz	0.926	158.09	1.25	23.97	0.016	26.10	0.835	162.98
2.7 GHz	0.923	156.91	1.24	21.33	0.017	25.64	0.831	162.13
2.8 GHz	0.919	155.68	1.22	18.65	0.018	25.07	0.828	161.26
2.9 GHz	0.914	154.40	1.22	15.94	0.019	24.37	0.824	160.37
3.0 GHz	0.910	153.06	1.21	13.17	0.020	23.55	0.819	159.45
3.2 GHz	0.904	151.67	1.21	10.35	0.022	22.60	0.814	158.50
3.4 GHz	0.898	150.20	1.22	7.47	0.023	21.51	0.809	157.52
3.6 GHz	0.892	148.67	1.22	4.51	0.025	20.29	0.802	156.51
3.8 GHz	0.884	147.05	1.23	1.48	0.027	18.92	0.796	155.47
4.0 GHz	0.876	145.36	1.25	-1.63	0.029	17.39	0.788	154.40
4.2 GHz	0.867	143.56	1.26	-4.85	0.032	15.71	0.780	153.30
4.4 GHz	0.857	141.67	1.29	-8.17	0.034	13.86	0.772	152.17
4.6 GHz	0.846	139.67	1.31	-11.62	0.037	11.84	0.762	151.02
4.8 GHz	0.834	137.55	1.34	-15.19	0.040	9.63	0.752	149.84
5.0 GHz	0.820	135.30	1.37	-18.90	0.044	7.23	0.740	148.65
5.2 GHz	0.883	137.25	0.71	-16.29	0.064	34.45	0.805	152.81
5.4 GHz	0.866	132.84	0.74	-21.37	0.074	30.53	0.791	150.19
5.6 GHz	0.845	127.78	0.78	-26.94	0.086	25.97	0.774	147.33
5.8 GHz	0.820	121.95	0.83	-33.09	0.101	20.69	0.755	144.21
6.0 GHz	0.789	115.17	0.88	-39.95	0.118	14.58	0.731	140.79

To download the s-parameters in s2p format, go to the CG2H40120F Product page.

Product Dimensions CG2H40120F (Package Type — 440223)

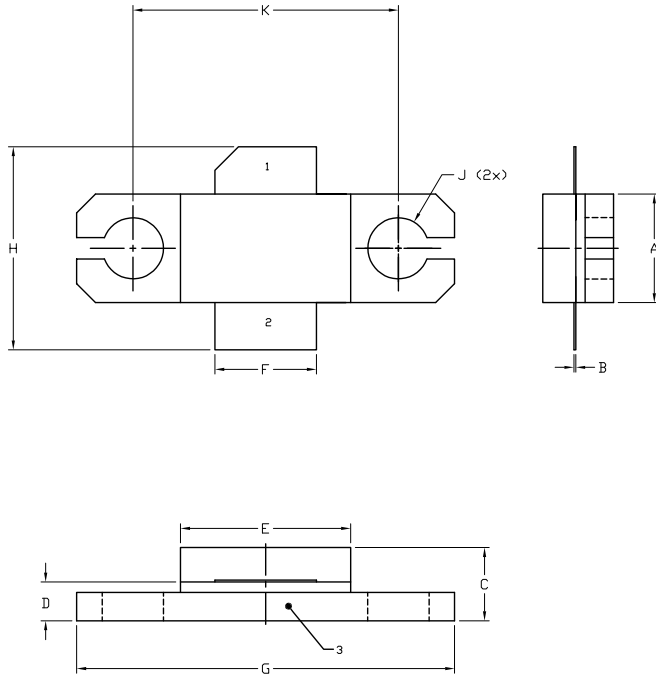

NOTES:

1. DIMENSIONING AND TOLERANCING PER ANSI Y14.5M, 1982.
2. CONTROLLING DIMENSION: INCH.
3. ADHESIVE FROM LID MAY EXTEND A MAXIMUM OF 0.020" BEYOND EDGE OF LID.
4. LID MAY BE MISALIGNED TO THE BODY OF THE PACKAGE BY A MAXIMUM OF 0.008" IN ANY DIRECTION.
5. ALL PLATED SURFACES ARE NI/AU

DIM	INCHES		MILLIMETERS	
	MIN	MAX	MIN	MAX
A	0.225	0.235	5.72	5.97
B	0.004	0.006	0.10	0.15
C	0.145	0.165	3.68	4.19
D	0.077	0.087	1.96	2.21
E	0.355	0.365	9.02	9.27
F	0.210	0.220	5.33	5.59
G	0.795	0.805	20.19	20.45
H	0.400	0.460	10.16	11.68
J	∅ .130		3.30	
k		0.562		14.27

- PIN 1. GATE
 PIN 2. DRAIN
 PIN 3. SOURCE

Product Dimensions CG2H40120P (Package Type — 440206)

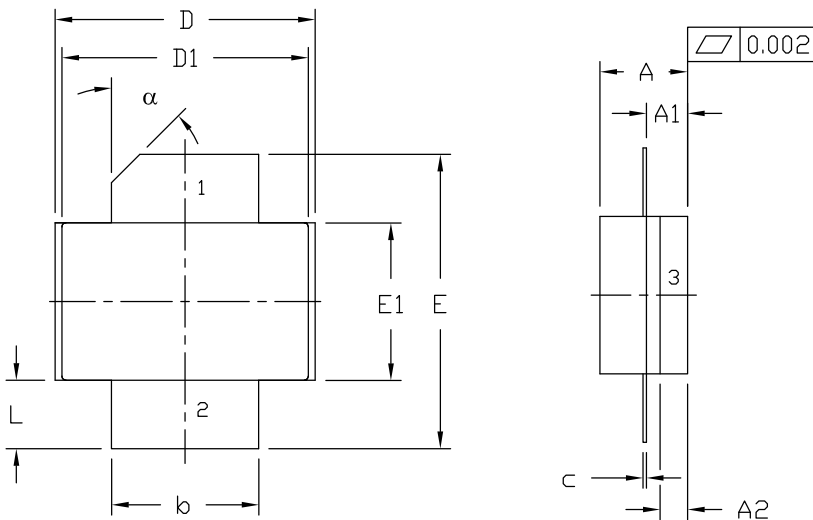



NOTES:

1. DIMENSIONING AND TOLERANCING PER ANSI Y14.5M - 1994.
2. CONTROLLING DIMENSION: INCH.
3. ADHESIVE FROM LID MAY EXTEND A MAXIMUM OF 0.020" BEYOND EDGE OF LID.
4. LID MAY BE MISALIGNED TO THE BODY OF PACKAGE BY A MAXIMUM OF 0.008" IN ANY DIRECTION.

DIM	INCHES		MILLIMETERS		NOTES
	MIN	MAX	MIN	MAX	
A	0.125	0.145	3.18	3.68	
A1	0.057	0.067	1.45	1.70	
A2	0.035	0.045	0.89	1.14	
b	0.210	0.220	5.33	5.59	2x
c	0.004	0.006	0.10	0.15	2x
D	0.375	0.385	9.53	9.78	
D1	0.355	0.365	9.02	9.27	
E	0.400	0.460	10.16	11.68	
E1	0.225	0.235	5.72	5.97	
L	0.085	0.115	2.16	2.92	2x
α	45° REF		45° REF		

- PIN 1. GATE
 PIN 2. DRAIN
 PIN 3. SOURCE

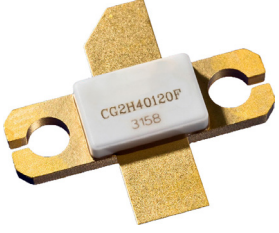
Product Ordering Information

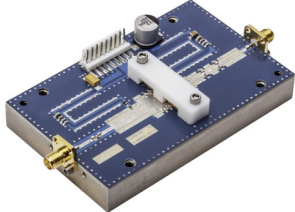
Order Number	Description	Unit of Measure	Image
CG2H40120F	GaN HEMT	Each	
CG2H40120P	GaN HEMT	Each	
CGH40120F-AMP	Test board with GaN HEMT (flange) installed	Each	

Notes & Disclaimer

MACOM Technology Solutions Inc. ("MACOM"). All rights reserved.

These materials are provided in connection with MACOM's products as a service to its customers and may be used for informational purposes only. Except as provided in its Terms and Conditions of Sale or any separate agreement, MACOM assumes no liability or responsibility whatsoever, including for (i) errors or omissions in these materials; (ii) failure to update these materials; or (iii) conflicts or incompatibilities arising from future changes to specifications and product descriptions, which MACOM may make at any time, without notice. These materials grant no license, express or implied, to any intellectual property rights.

THESE MATERIALS ARE PROVIDED "AS IS" WITH NO WARRANTY OR LIABILITY, EXPRESS OR IMPLIED, RELATING TO SALE AND/OR USE OF MACOM PRODUCTS INCLUDING FITNESS FOR A PARTICULAR PURPOSE, MERCHANTABILITY, INFRINGEMENT OF INTELLECTUAL PROPERTY RIGHT, ACCURACY OR COMPLETENESS, OR SPECIAL, INDIRECT, INCIDENTAL, OR CONSEQUENTIAL DAMAGES WHICH MAY RESULT FROM USE OF THESE MATERIALS.

MACOM products are not intended for use in medical, lifesaving or life sustaining applications. MACOM customers using or selling MACOM products for use in such applications do so at their own risk and agree to fully indemnify MACOM for any damages resulting from such improper use or sale.