

DataSheet No: C16009

Version:V4

Date:2024/03/24



PCSR2512

High-Precision Low-TCR Molded Alloy Current Sensing Resistor

Resistance	5mΩ~100mΩ
Tolerance	±0.1%
TCR	±15ppm/°C
Rated Current	3A~14A

Applications

Automotive Electronics
Precision Power Supply
Instrumentation
Sorting & Formation of Battery
Medical Equipment

**Better Solution for Sustainable
High End Manufacturing**



Tolerance of $\pm 0.1\%$ and TCR of $\pm 15\text{ppm}$ High Reliability and Stability

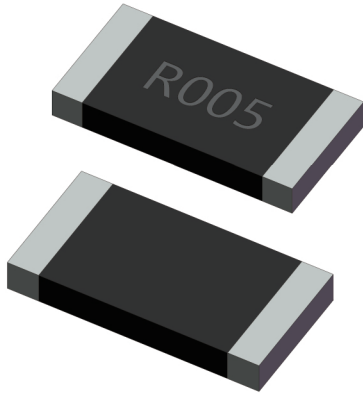

Introduction

High-precision low-TCR molded alloy current sensing resistor adopts a resistive alloy independently developed by C&B Electronics, which undergoes precision processing, then is welded by a dedicated electron beam welding equipment independently designed and manufactured by C&B Electronics to achieve continuous welding, and then is shaped by precision stamping. Based on the control ability of the resistance alloy's consistency, precision processing ability, process control ability, and precision welding ability, the product can achieve a maximum target tolerance of $\pm 0.1\%$ after precision trimming. Finally, the product is encapsulated through precision molding.

The resistance range of PCSR2512 series of products is $5\text{m}\Omega\sim 100\text{m}\Omega$. TCR of PCSR2512 series is $\leq \pm 15\text{ppm}/^\circ\text{C}$ within the operating temperature range from -55°C to $+125^\circ\text{C}$. By controlling the resistive alloy materials, precision electron beam welding processes and subsequent processes, the thermal EMF is significantly reduced, while significantly improving its long-term stability.

PCSR2512 series, from raw materials, core equipment, to core processes, achieves independent and controllable production, stable quality, and timely delivery. If the standard specifications cannot meet your needs, please contact our sales for consultation. Resi is committed to providing the best precision resistor solutions to meet the needs of customers in testing and measurement, power equipment, medical equipment, precision power supply, automotive electronics, formation & sorting of battery.



Electrical Parameters

Size	Resistance	Rated Power (+70°C)	Max. Operating Current	Operating Temperature	TCR ppm/°C(+20°CRef)	Tolerance %
PCSR2512	5mΩ~9mΩ	1W	10A~14A	-55°C~+170°C	$\pm 15(-55^\circ\text{C}\sim +125^\circ\text{C})$	± 0.1 ± 0.5 ± 1.0 ± 5.0
PCSR2512	10mΩ~100mΩ	1W	3A~10A	-55°C~+170°C	$\pm 15(-55^\circ\text{C}\sim +125^\circ\text{C})$	± 0.1 ± 0.5 ± 1.0 ± 5.0

Applications

PCSR series is applicable to AC, DC, high and low-frequency sampling circuits.

Dimensions

Resistor

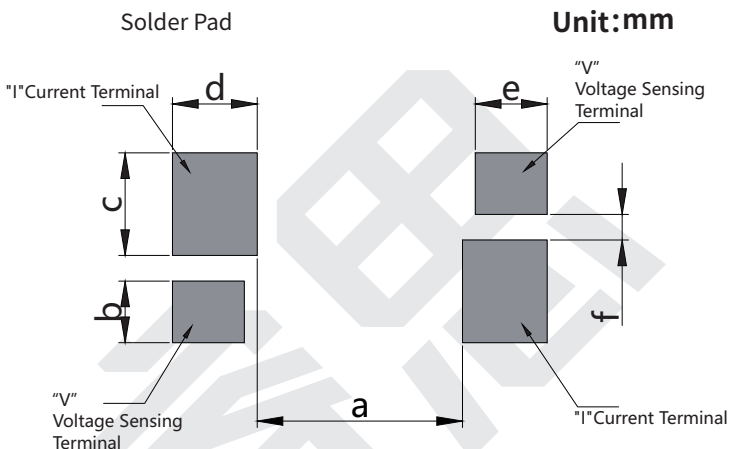
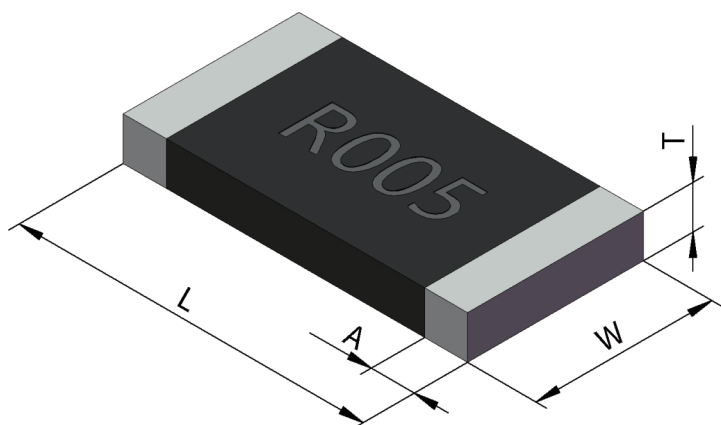

Not following the recommended solder pad design can seriously affect the temperature coefficient measurement results and current sensing accuracy!

Resistance	L	W	A	T	a	b
5mΩ~100mΩ	6.4±0.2	3.2±0.2	0.8±0.2	0.8±0.1	4.0	1.2
c	d	e	f	Packaging	Quantity Per Reel	Net Weight
2.0	1.65	1.4	0.5	Tape & Reel	4000pcs	0.07±0.02g

Part Number Information

Example: PCSR2512BR005M9 (PCSR 2512 ±0.1% 5mΩ ±15ppm/°C Marked)

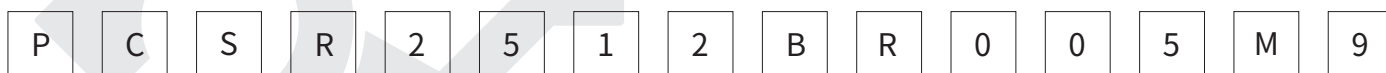

Series	Size	Tolerance	Resistance ^{1,2}	TCR	Packaging
PCSR	2512	B=±0.1% D=±0.5% F=±1.0% J=±5.0%	R005=5mΩ R010=10mΩ R100=100mΩ	M=±15ppm/°C	9=Marked 6=Unmarked

1. There are situations where the expression of resistance value exceeds four digits. 49.9mohm expresses as R0499, and 49.99mohm expresses as R04999, etc.
2. For higher/lower resistance, tighter tolerance, higher power, lower TCR and larger size, please contact us.

Performance

Test	Test Method	Standards	Typical	Max.
High Temperature Storage	1000h@+170°C, unpowered	AEC-Q200 TEST 3 MIL-STD-202 Method 108	$\Delta R \leq \pm 0.1\%$	$\Delta R \leq \pm 0.3\%$
Thermal Shock	-55°C, 15min~ambient temperature<20s~+155°C, 15min, 1000 cycles	AEC-Q200 TEST 16 MIL-STD-202 Method 107	$\Delta R \leq \pm 0.1\%$	$\Delta R \leq \pm 0.3\%$
Bias Humidity	+85°C, 85%RH, powered no less than 10% rated power for 1000h	AEC-Q200 TEST 7 MIL-STD-202 Method 103	$\Delta R \leq \pm 0.05\%$	$\Delta R \leq \pm 0.2\%$
Load Life	2000h @ +70°C, rated power, 90min on, 30min off +70°C refers to terminal temperature	AEC-Q200 TEST 8 MIL-STD-202 Method 108	$\Delta R \leq \pm 0.5\%$	$\Delta R \leq \pm 1.0\%$
Resistance to Solvent	Immerse in solvent for 3 min and wipe 10 times. Three cycles of three solvents. Dry at ambient temperature after cleaning	AEC-Q200 TEST 12 MIL-STD-202 Method 215	Clear marking. No visible damage	
Mechanical Shock	Half Sine Wave, peak acceleration 100g's, pulse duration 6ms, 3 times in each of six directions, on three different axes	AEC-Q200 TEST 13 MIL-STD-202 Method 213	$\Delta R \leq \pm 0.02\%$	$\Delta R \leq \pm 0.05\%$
Vibration	10-2KHz, 5g's, 20min/cycle, 12 cycles in each directions of X Y Z	AEC-Q200 TEST 14 MIL-STD-202 Method 204	$\Delta R \leq \pm 0.02\%$	$\Delta R \leq \pm 0.05\%$
Resistance to Solder Heat	+260°C tin bath for 10s	AEC-Q200 TEST 15 MIL-STD-202 Method 210	$\Delta R \leq \pm 0.05\%$	$\Delta R \leq \pm 0.1\%$
Solderability	+245°C tin bath for 3s	AEC-Q200 TEST 18 IEC 60115-1 4.17	No visible damage. 95% minimum coverage	
TCR	-55°C and +125°C, +20°C Ref.	AEC-Q200 TEST 19 IEC 60115-1 4.8	Refer to tested curve, max. value $\leq 15\text{ppm}/^\circ\text{C}$	
Substrate Bending	2mm. Duration: 60s.	AEC-Q200 TEST 21 AEC-Q200-005	$\Delta R \leq \pm 0.1\%$	$\Delta R \leq \pm 0.5\%$
Short Time Overload	5x rated voltage, 5s	IEC 60115-1 4.13	$\Delta R \leq \pm 0.1\%$	$\Delta R \leq \pm 0.5\%$
Low Temperature Storage	-55°C for 96h, unpowered	IEC 60068-2-1	$\Delta R \leq \pm 0.1\%$	$\Delta R \leq \pm 0.5\%$
Moisture Resistance	Apply T=24 h/cycle, zero power, method 7a and 7b are not required	MIL-STD-202 Method 106	$\Delta R \leq \pm 0.02\%$	$\Delta R \leq \pm 0.05\%$

Temperature Coefficient of Resistance Test Curve

TCR Test Curve - PCSR2512 5mΩ

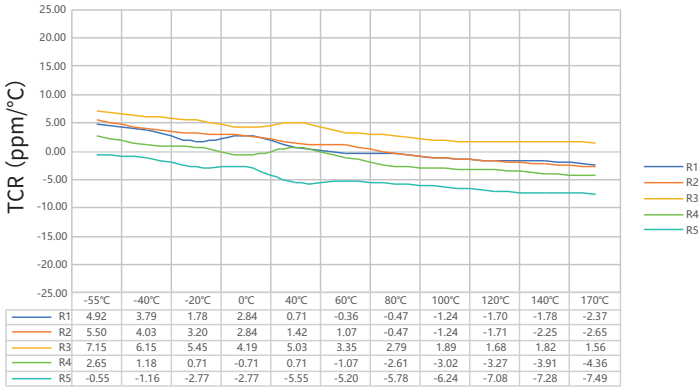

TCR Test Curve - PCSR2512 9mΩ

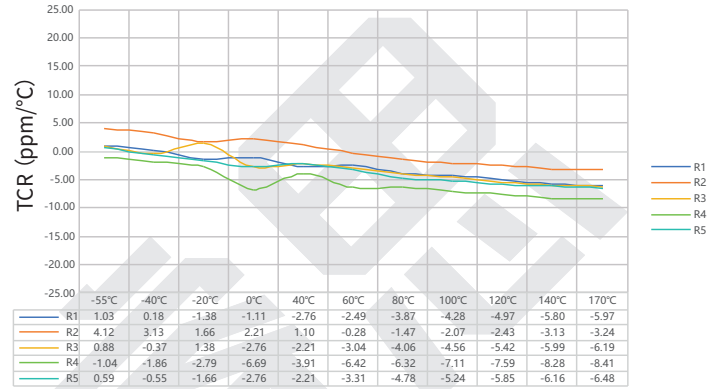

Temperature (°C)

Temperature (°C)

TCR Test Curve - PCSR2512 10mΩ

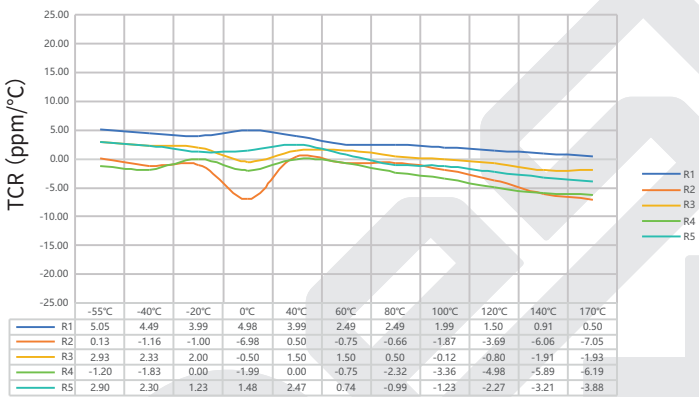

Temperature (°C)

TCR Test Curve - PCSR2512 20mΩ

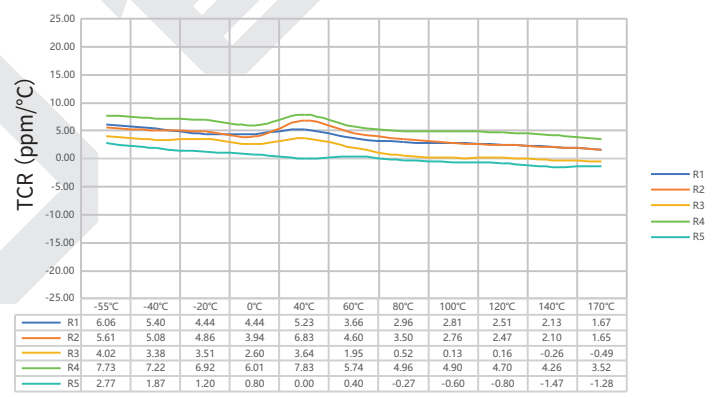

Temperature (°C)

TCR Test Curve - PCSR2512 50mΩ

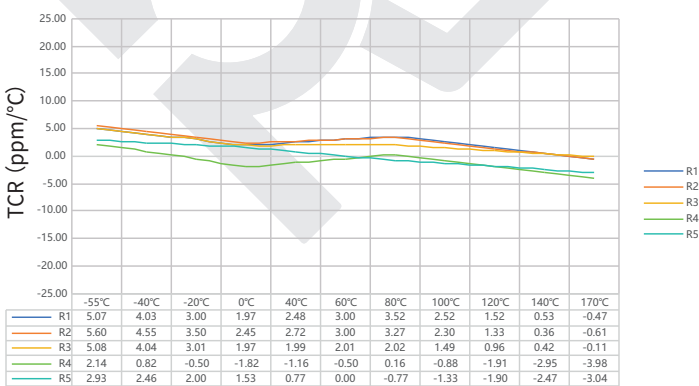

Temperature (°C)

TCR Test Curve - PCSR2512 100mΩ

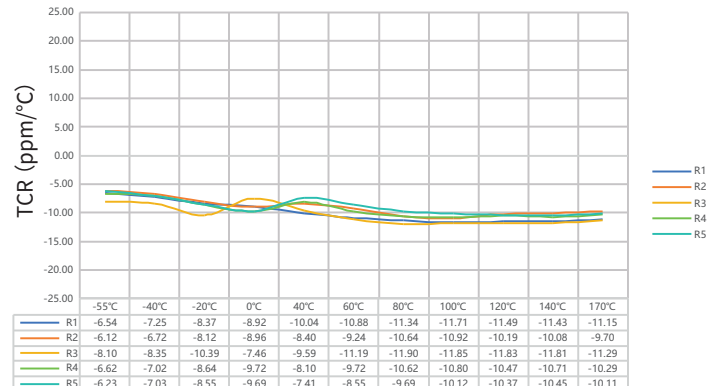

Temperature (°C)

Derating Curve

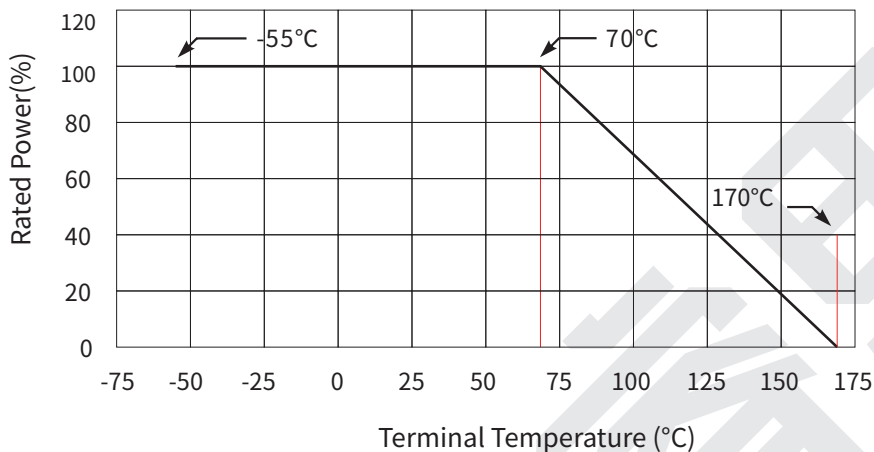

Reflow Soldering Profile

Resistor Surface Temperature:
 Pre-Heat: +150°C~+190°C, 60~120sec.
 Reflow: Above +220°C, 90~150sec.
 Applicable Solder Composition: Sn-Ag-Cu

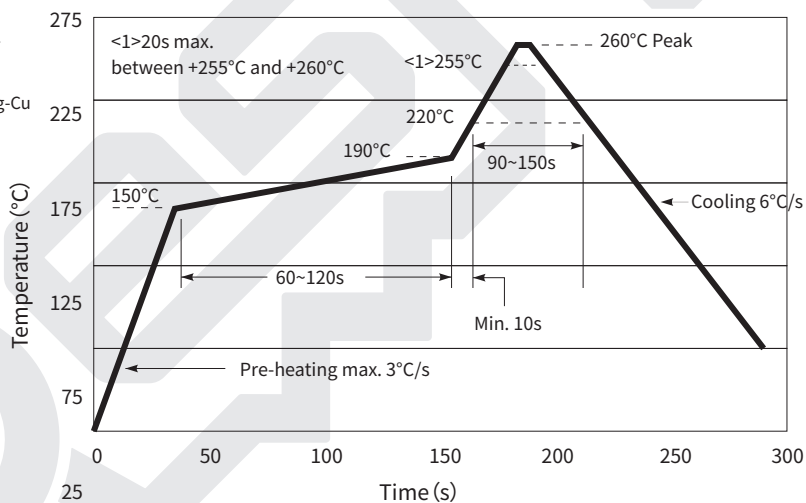

Construction

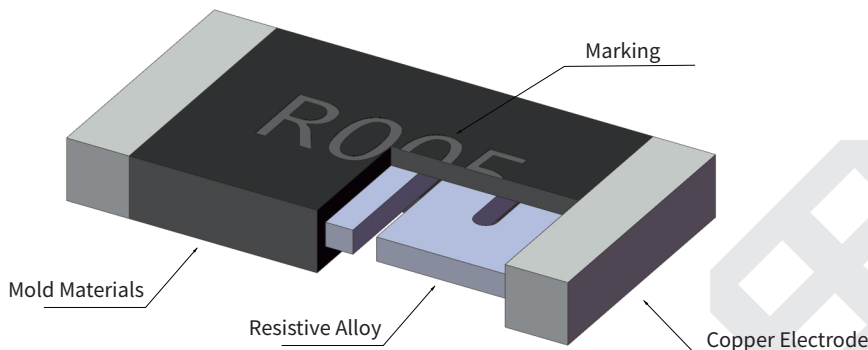

Marking

Marking: Resistance

Size	Illustration	Demonstration
2512		R005=5mΩ R100=100mΩ

Storage Instructions

- (1) Resistors should be stored at a temperature of 5 to 35 °C, with a humidity of <60% RH. The humidity should be kept as low as possible.
- (2) Resistors should be protected from direct sunlight.
- (3) Resistors should be stored in a clean and dry environment free of harmful gases (HCl, Sulfuric acid, H₂S, etc.)
- (4) Do not move the resistor from the packaging unless use it.
- (5) Under the above storage conditions, the resistor can be stored for at least 1 year.

Usage Suggestions

- (1) Please protect the surface of the resistor during use. Prevent defects such as scratches, bumps, and oil stains on the surface.
- (2) Do not use sharp tweezers to move the resistor. Scratches on the surface can cause resistance drift and resistor failure.
- (3) When installing and using resistors, avoid the impact of mechanical stress on the resistor.
- (4) The long-term operating power of resistors should be \leq rated power to avoid resistance drift caused by long-term overload.
- (5) Please refer to the derating curve when operating under high temperature conditions or poor heat dissipation environment.
- (6) If the operating conditions exceed the pulse specified in the pulse curve, a systematic evaluation is required.
- (7) If the resistor is not used after being moved from the packaging, it should be stored under vacuum to avoid risks such as poor welding caused by oxidation of the resistor.

Packaging

Tape Specifications

Unit:mm

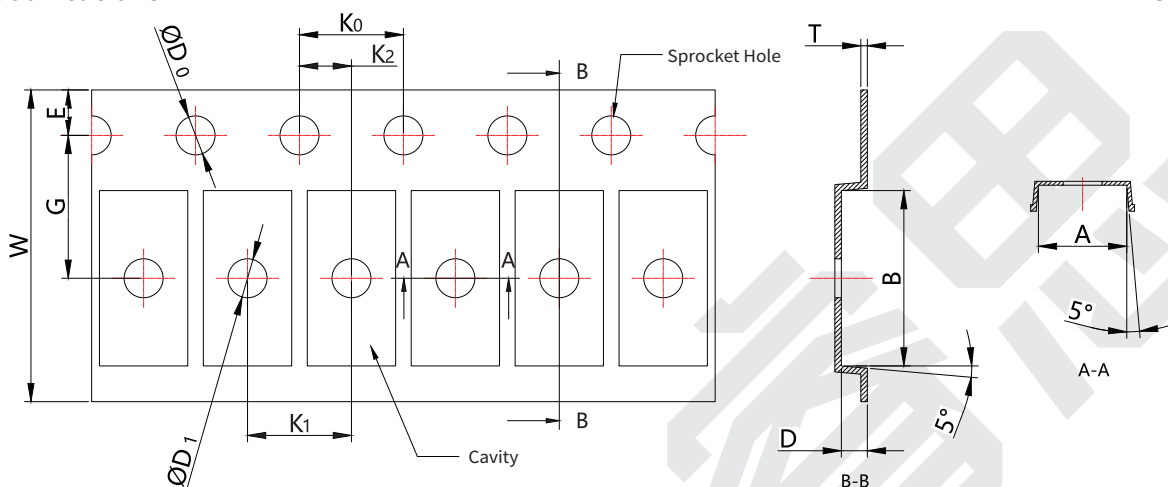

Resistance	A	B	ϕD_0	ϕD_1	K_0	K_1	K_2	E	G	W	D	T
5m Ω -100m Ω	3.40 \pm 0.2	6.75 \pm 0.2	1.5 \pm 0.1	1.5 \pm 0.1	4.0 \pm 0.1	4.0 \pm 0.1	2.0 \pm 0.1	1.75 \pm 0.1	5.5 \pm 0.1	12.0 \pm 0.3	1.0 \pm 0.1	0.25 \pm 0.05

Reel Specifications

Unit:mm

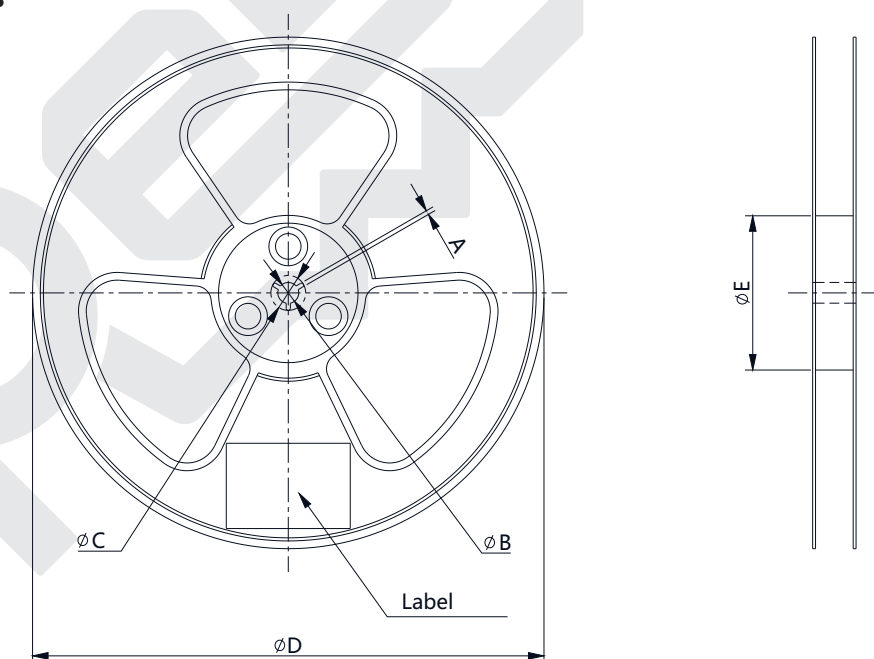

A	ϕB	ϕC	ϕD	ϕE
1.5 min.	13.5 +0.5/-0.2	20.2 Min.	178 \pm 2	60 \pm 2

Packaging

- (1) 4000 pcs. resistors are packed in a tape and wrapped in a reel;
- (2) Every 2 reels are packed by a cardboard sleeve case. The size of the cardboard is 180mm*180mm*35mm;
- (3) Place every 8 cases into a box (64000 pcs. / box);
- (4) Box size: 330mm*195mm*200mm.

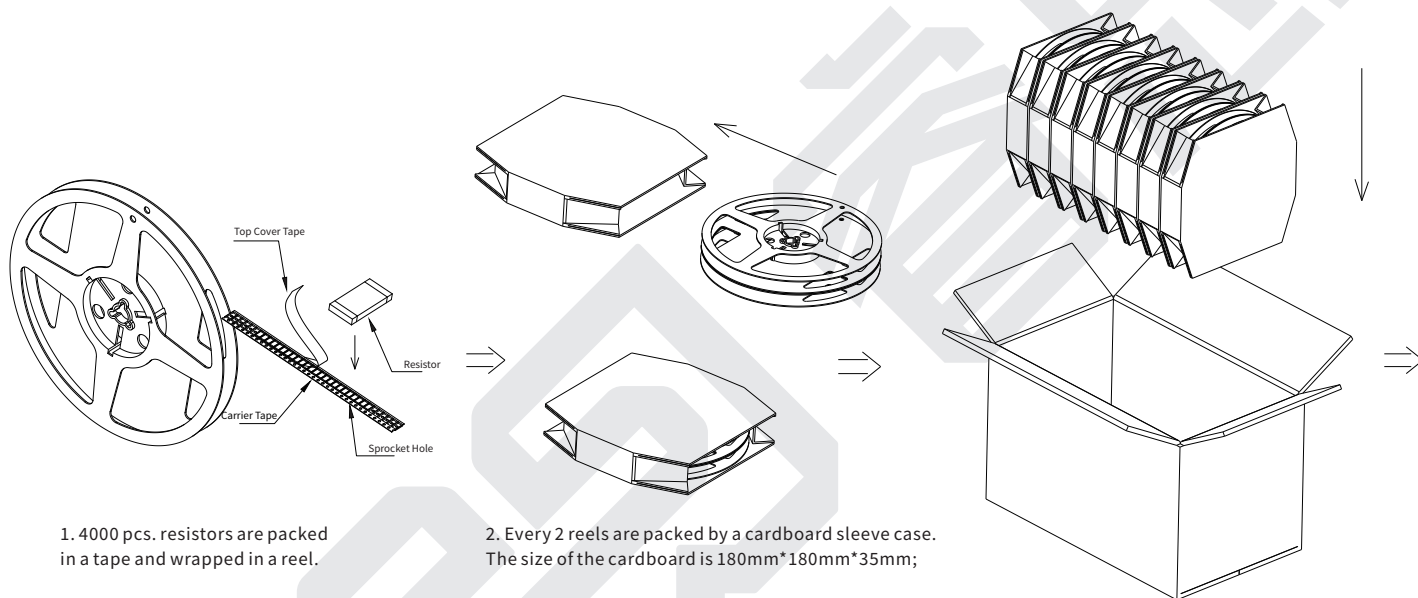

1. 4000 pcs. resistors are packed in a tape and wrapped in a reel.

2. Every 2 reels are packed by a cardboard sleeve case. The size of the cardboard is 180mm*180mm*35mm;

3. Place every 8 cases into a box (64000 pcs. / box).

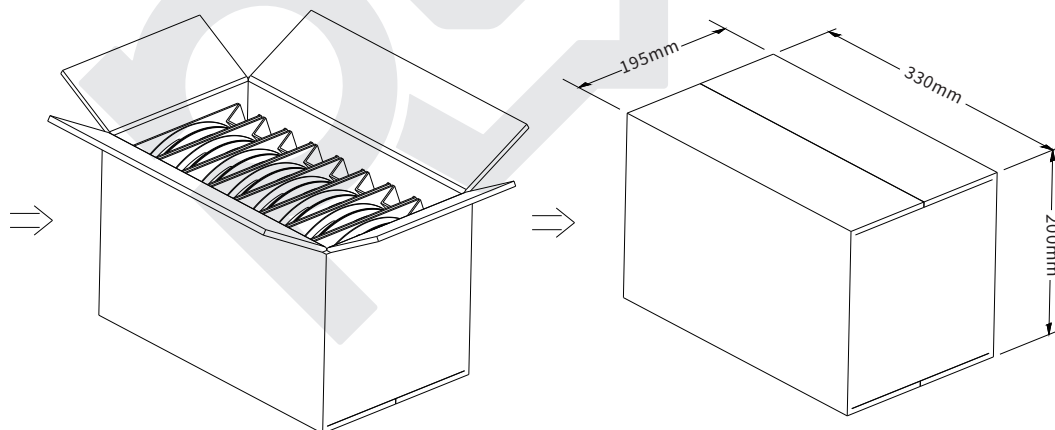

4. For the last box, 8 cardboard sleeve cases should be placed regardless of quantity of the product, preventing shaking.

5. Box size: 330mm*195mm*200mm

High-Precision Low-TCR Molded Alloy Current Sensing Resistor

Popular Part Numbers

Part Number	Size	Tolerance	Resistance	Marking	TCR	Power	Max. Operating Current
PCSR2512BR005M9	2512	±0.1%	5.0mΩ	Marked	±15ppm/°C	1W	14A
PCSR2512DR005M9	2512	±0.5%	5.0mΩ	Marked	±15ppm/°C	1W	14A
PCSR2512FR005M9	2512	±1.0%	5.0mΩ	Marked	±15ppm/°C	1W	14A
PCSR2512JR005M9	2512	±5.0%	5.0mΩ	Marked	±15ppm/°C	1W	14A
PCSR2512BR006M9	2512	±0.1%	6.0mΩ	Marked	±15ppm/°C	1W	12A
PCSR2512DR006M9	2512	±0.5%	6.0mΩ	Marked	±15ppm/°C	1W	12A
PCSR2512FR006M9	2512	±1.0%	6.0mΩ	Marked	±15ppm/°C	1W	12A
PCSR2512JR006M9	2512	±5.0%	6.0mΩ	Marked	±15ppm/°C	1W	12A
PCSR2512BR007M9	2512	±0.1%	7.0mΩ	Marked	±15ppm/°C	1W	11A
PCSR2512DR007M9	2512	±0.5%	7.0mΩ	Marked	±15ppm/°C	1W	11A
PCSR2512FR007M9	2512	±1.0%	7.0mΩ	Marked	±15ppm/°C	1W	11A
PCSR2512JR007M9	2512	±5.0%	7.0mΩ	Marked	±15ppm/°C	1W	11A
PCSR2512BR008M9	2512	±0.1%	8.0mΩ	Marked	±15ppm/°C	1W	11A
PCSR2512DR008M9	2512	±0.5%	8.0mΩ	Marked	±15ppm/°C	1W	11A
PCSR2512FR008M9	2512	±1.0%	8.0mΩ	Marked	±15ppm/°C	1W	11A
PCSR2512JR008M9	2512	±5.0%	8.0mΩ	Marked	±15ppm/°C	1W	11A
PCSR2512BR009M9	2512	±0.1%	9.0mΩ	Marked	±15ppm/°C	1W	10A
PCSR2512DR009M9	2512	±0.5%	9.0mΩ	Marked	±15ppm/°C	1W	10A
PCSR2512FR009M9	2512	±1.0%	9.0mΩ	Marked	±15ppm/°C	1W	10A
PCSR2512JR009M9	2512	±5.0%	9.0mΩ	Marked	±15ppm/°C	1W	10A
PCSR2512BR010M9	2512	±0.1%	10mΩ	Marked	±15ppm/°C	1W	10A
PCSR2512DR010M9	2512	±0.5%	10mΩ	Marked	±15ppm/°C	1W	10A
PCSR2512FR010M9	2512	±1.0%	10mΩ	Marked	±15ppm/°C	1W	10A
PCSR2512JR010M9	2512	±5.0%	10mΩ	Marked	±15ppm/°C	1W	10A
PCSR2512BR015M9	2512	±0.1%	15mΩ	Marked	±15ppm/°C	1W	8A
PCSR2512DR015M9	2512	±0.5%	15mΩ	Marked	±15ppm/°C	1W	8A
PCSR2512FR015M9	2512	±1.0%	15mΩ	Marked	±15ppm/°C	1W	8A
PCSR2512JR015M9	2512	±5.0%	15mΩ	Marked	±15ppm/°C	1W	8A
PCSR2512BR018M9	2512	±0.1%	18mΩ	Marked	±15ppm/°C	1W	7A
PCSR2512DR018M9	2512	±0.5%	18mΩ	Marked	±15ppm/°C	1W	7A
PCSR2512FR018M9	2512	±1.0%	18mΩ	Marked	±15ppm/°C	1W	7A
PCSR2512JR018M9	2512	±5.0%	18mΩ	Marked	±15ppm/°C	1W	7A

High-Precision Low-TCR Molded Alloy Current Sensing Resistor

Popular Part Numbers

Part Number	Size	Tolerance	Resistance	Marking	TCR	Power	Max. Operating Current
PCSR2512BR020M9	2512	±0.1%	20mΩ	Marked	±15ppm/°C	1W	7A
PCSR2512DR020M9	2512	±0.5%	20mΩ	Marked	±15ppm/°C	1W	7A
PCSR2512FR020M9	2512	±1.0%	20mΩ	Marked	±15ppm/°C	1W	7A
PCSR2512JR020M9	2512	±5.0%	20mΩ	Marked	±15ppm/°C	1W	7A
PCSR2512BR025M9	2512	±0.1%	25mΩ	Marked	±15ppm/°C	1W	6A
PCSR2512DR025M9	2512	±0.5%	25mΩ	Marked	±15ppm/°C	1W	6A
PCSR2512FR025M9	2512	±1.0%	25mΩ	Marked	±15ppm/°C	1W	6A
PCSR2512JR025M9	2512	±5.0%	25mΩ	Marked	±15ppm/°C	1W	6A
PCSR2512BR030M9	2512	±0.1%	30mΩ	Marked	±15ppm/°C	1W	5A
PCSR2512DR030M9	2512	±0.5%	30mΩ	Marked	±15ppm/°C	1W	5A
PCSR2512FR030M9	2512	±1.0%	30mΩ	Marked	±15ppm/°C	1W	5A
PCSR2512JR030M9	2512	±5.0%	30mΩ	Marked	±15ppm/°C	1W	5A
PCSR2512BR033M9	2512	±0.1%	33mΩ	Marked	±15ppm/°C	1W	5A
PCSR2512DR033M9	2512	±0.5%	33mΩ	Marked	±15ppm/°C	1W	5A
PCSR2512FR033M9	2512	±1.0%	33mΩ	Marked	±15ppm/°C	1W	5A
PCSR2512JR033M9	2512	±5.0%	33mΩ	Marked	±15ppm/°C	1W	5A
PCSR2512BR040M9	2512	±0.1%	40mΩ	Marked	±15ppm/°C	1W	5A
PCSR2512DR040M9	2512	±0.5%	40mΩ	Marked	±15ppm/°C	1W	5A
PCSR2512FR040M9	2512	±1.0%	40mΩ	Marked	±15ppm/°C	1W	5A
PCSR2512JR040M9	2512	±5.0%	40mΩ	Marked	±15ppm/°C	1W	5A
PCSR2512BR047M9	2512	±0.1%	47mΩ	Marked	±15ppm/°C	1W	4A
PCSR2512DR047M9	2512	±0.5%	47mΩ	Marked	±15ppm/°C	1W	4A
PCSR2512FR047M9	2512	±1.0%	47mΩ	Marked	±15ppm/°C	1W	4A
PCSR2512JR047M9	2512	±5.0%	47mΩ	Marked	±15ppm/°C	1W	4A
PCSR2512BR050M9	2512	±0.1%	50mΩ	Marked	±15ppm/°C	1W	4A
PCSR2512DR050M9	2512	±0.5%	50mΩ	Marked	±15ppm/°C	1W	4A
PCSR2512FR050M9	2512	±1.0%	50mΩ	Marked	±15ppm/°C	1W	4A
PCSR2512JR050M9	2512	±5.0%	50mΩ	Marked	±15ppm/°C	1W	4A
PCSR2512BR100M9	2512	±0.1%	100mΩ	Marked	±15ppm/°C	1W	3A
PCSR2512DR100M9	2512	±0.5%	100mΩ	Marked	±15ppm/°C	1W	3A
PCSR2512FR100M9	2512	±1.0%	100mΩ	Marked	±15ppm/°C	1W	3A
PCSR2512JR100M9	2512	±5.0%	100mΩ	Marked	±15ppm/°C	1W	3A

Popular Part Numbers

Part Number	Size	Tolerance	Resistance	Marking	TCR	Power	Max. Operating Current
PCSR2512BR005M6	2512	±0.1%	5.0mΩ	Unmarked	±15ppm/°C	1W	14A
PCSR2512DR005M6	2512	±0.5%	5.0mΩ	Unmarked	±15ppm/°C	1W	14A
PCSR2512FR005M6	2512	±1.0%	5.0mΩ	Unmarked	±15ppm/°C	1W	14A
PCSR2512JR005M6	2512	±5.0%	5.0mΩ	Unmarked	±15ppm/°C	1W	14A
PCSR2512BR006M6	2512	±0.1%	6.0mΩ	Unmarked	±15ppm/°C	1W	12A
PCSR2512DR006M6	2512	±0.5%	6.0mΩ	Unmarked	±15ppm/°C	1W	12A
PCSR2512FR006M6	2512	±1.0%	6.0mΩ	Unmarked	±15ppm/°C	1W	12A
PCSR2512JR006M6	2512	±5.0%	6.0mΩ	Unmarked	±15ppm/°C	1W	12A
PCSR2512BR007M6	2512	±0.1%	7.0mΩ	Unmarked	±15ppm/°C	1W	11A
PCSR2512DR007M6	2512	±0.5%	7.0mΩ	Unmarked	±15ppm/°C	1W	11A
PCSR2512FR007M6	2512	±1.0%	7.0mΩ	Unmarked	±15ppm/°C	1W	11A
PCSR2512JR007M6	2512	±5.0%	7.0mΩ	Unmarked	±15ppm/°C	1W	11A
PCSR2512BR008M6	2512	±0.1%	8.0mΩ	Unmarked	±15ppm/°C	1W	11A
PCSR2512DR008M6	2512	±0.5%	8.0mΩ	Unmarked	±15ppm/°C	1W	11A
PCSR2512FR008M6	2512	±1.0%	8.0mΩ	Unmarked	±15ppm/°C	1W	11A
PCSR2512JR008M6	2512	±5.0%	8.0mΩ	Unmarked	±15ppm/°C	1W	11A
PCSR2512BR009M6	2512	±0.1%	9.0mΩ	Unmarked	±15ppm/°C	1W	10A
PCSR2512DR009M6	2512	±0.5%	9.0mΩ	Unmarked	±15ppm/°C	1W	10A
PCSR2512FR009M6	2512	±1.0%	9.0mΩ	Unmarked	±15ppm/°C	1W	10A
PCSR2512JR009M6	2512	±5.0%	9.0mΩ	Unmarked	±15ppm/°C	1W	10A
PCSR2512BR010M6	2512	±0.1%	10mΩ	Unmarked	±15ppm/°C	1W	10A
PCSR2512DR010M6	2512	±0.5%	10mΩ	Unmarked	±15ppm/°C	1W	10A
PCSR2512FR010M6	2512	±1.0%	10mΩ	Unmarked	±15ppm/°C	1W	10A
PCSR2512JR010M6	2512	±5.0%	10mΩ	Unmarked	±15ppm/°C	1W	10A
PCSR2512BR015M6	2512	±0.1%	15mΩ	Unmarked	±15ppm/°C	1W	8A
PCSR2512DR015M6	2512	±0.5%	15mΩ	Unmarked	±15ppm/°C	1W	8A
PCSR2512FR015M6	2512	±1.0%	15mΩ	Unmarked	±15ppm/°C	1W	8A
PCSR2512JR015M6	2512	±5.0%	15mΩ	Unmarked	±15ppm/°C	1W	8A
PCSR2512BR018M6	2512	±0.1%	18mΩ	Unmarked	±15ppm/°C	1W	7A
PCSR2512DR018M6	2512	±0.5%	18mΩ	Unmarked	±15ppm/°C	1W	7A
PCSR2512FR018M6	2512	±1.0%	18mΩ	Unmarked	±15ppm/°C	1W	7A
PCSR2512JR018M6	2512	±5.0%	18mΩ	Unmarked	±15ppm/°C	1W	7A

Popular Part Numbers

Part Number	Size	Tolerance	Resistance	Marking	TCR	Power	Max. Operating Current
PCSR2512BR020M6	2512	±0.1%	20mΩ	Unmarked	±15ppm/°C	1W	7A
PCSR2512DR020M6	2512	±0.5%	20mΩ	Unmarked	±15ppm/°C	1W	7A
PCSR2512FR020M6	2512	±1.0%	20mΩ	Unmarked	±15ppm/°C	1W	7A
PCSR2512JR020M6	2512	±5.0%	20mΩ	Unmarked	±15ppm/°C	1W	7A
PCSR2512BR025M6	2512	±0.1%	25mΩ	Unmarked	±15ppm/°C	1W	6A
PCSR2512DR025M6	2512	±0.5%	25mΩ	Unmarked	±15ppm/°C	1W	6A
PCSR2512FR025M6	2512	±1.0%	25mΩ	Unmarked	±15ppm/°C	1W	6A
PCSR2512JR025M6	2512	±5.0%	25mΩ	Unmarked	±15ppm/°C	1W	6A
PCSR2512BR030M6	2512	±0.1%	30mΩ	Unmarked	±15ppm/°C	1W	5A
PCSR2512DR030M6	2512	±0.5%	30mΩ	Unmarked	±15ppm/°C	1W	5A
PCSR2512FR030M6	2512	±1.0%	30mΩ	Unmarked	±15ppm/°C	1W	5A
PCSR2512JR030M6	2512	±5.0%	30mΩ	Unmarked	±15ppm/°C	1W	5A
PCSR2512BR033M6	2512	±0.1%	33mΩ	Unmarked	±15ppm/°C	1W	5A
PCSR2512DR033M6	2512	±0.5%	33mΩ	Unmarked	±15ppm/°C	1W	5A
PCSR2512FR033M6	2512	±1.0%	33mΩ	Unmarked	±15ppm/°C	1W	5A
PCSR2512JR033M6	2512	±5.0%	33mΩ	Unmarked	±15ppm/°C	1W	5A
PCSR2512BR040M6	2512	±0.1%	40mΩ	Unmarked	±15ppm/°C	1W	5A
PCSR2512DR040M6	2512	±0.5%	40mΩ	Unmarked	±15ppm/°C	1W	5A
PCSR2512FR040M6	2512	±1.0%	40mΩ	Unmarked	±15ppm/°C	1W	5A
PCSR2512JR040M6	2512	±5.0%	40mΩ	Unmarked	±15ppm/°C	1W	5A
PCSR2512BR047M6	2512	±0.1%	47mΩ	Unmarked	±15ppm/°C	1W	4A
PCSR2512DR047M6	2512	±0.5%	47mΩ	Unmarked	±15ppm/°C	1W	4A
PCSR2512FR047M6	2512	±1.0%	47mΩ	Unmarked	±15ppm/°C	1W	4A
PCSR2512JR047M6	2512	±5.0%	47mΩ	Unmarked	±15ppm/°C	1W	4A
PCSR2512BR050M6	2512	±0.1%	50mΩ	Unmarked	±15ppm/°C	1W	4A
PCSR2512DR050M6	2512	±0.5%	50mΩ	Unmarked	±15ppm/°C	1W	4A
PCSR2512FR050M6	2512	±1.0%	50mΩ	Unmarked	±15ppm/°C	1W	4A
PCSR2512JR050M6	2512	±5.0%	50mΩ	Unmarked	±15ppm/°C	1W	4A
PCSR2512BR100M6	2512	±0.1%	100mΩ	Unmarked	±15ppm/°C	1W	3A
PCSR2512DR100M6	2512	±0.5%	100mΩ	Unmarked	±15ppm/°C	1W	3A
PCSR2512FR100M6	2512	±1.0%	100mΩ	Unmarked	±15ppm/°C	1W	3A
PCSR2512JR100M6	2512	±5.0%	100mΩ	Unmarked	±15ppm/°C	1W	3A

Revision

Version	Revised Content	Date	Approver
V0	Initial Issue	2019.12.26	YBP
V1	Change datasheet to the new template.	2020.02.27	YBP
V2	Improve the description of material information.	2020.03.09	YBP
V3	Change datasheet to the new template. Add 10-100mΩ specifications.	2022.07.17	LWW
V4	Change datasheet to the new template. Add 5-9mΩ specifications. Add product reliability information and packaging information.	2024.03.24	LWW

Disclaimer

All products, datasheets and data can be changed without prior notice.

C&B Electronics Shenzhen CO., LTD., its affiliates, distributors, employees, and any other person acting on its behalf (collectively referred to as "C&B Electronics") shall not bear any legal responsibility for any errors, inaccuracies, or incompleteness of information related to the product disclosed under this agreement or other disclosures.

Product datasheet does not constitute an extension or revision of the purchase terms and conditions in C&B Electronics, including but not limited to the warranties under this agreement.

Unless specified in the purchase terms and conditions, C&B Electronics makes no guarantees, representations or warranties.

To the maximum extent permitted by applicable laws, C&B Electronics hereby makes the following disclaimer:

- (1) All liabilities arising from the use of the product;**
- (2) Including but not limited to all liabilities arising from special, indirect or incidental damages;**
- (3) All implied warranties, including warranties of suitability for special purposes, non infringement possibility, and marketability.**

The information provided in the datasheet and parameter tables may vary in different applications, and the performance of the product may change over time. The recommended application instructions for the product are based on C&B Electronics' understanding and experience of typical requirements. Customers are obligated to verify whether the product is suitable for a specific application based on the parameters provided in the datasheet. Before officially installing or using the product, you should ensure that you have obtained the latest version of relevant information, which can be obtained through the website: resistor.today.

The signing of this agreement does not constitute an express, implied or other form of license related to all intellectual property rights of C&B Electronic Products.

Unless explicitly stated, the products listed in this agreement are not applicable to lifesaving or life sustaining products. In the absence of a clear indication, the customer shall bear all risks caused by unauthorized use of the above products and agree to fully compensate C&B Electronics for all losses caused by such sales or use. For written product terms for such special applications, please contact authorized personnel from C&B Electronics to obtain.

The names and markings on the listed products may be trademarks owned by others.