

1.View and size(视图及尺寸)

Main technical indicators(主要技术指标)	
1.Mating (插拔次数)	5000
2.Working Temperature (温度)	-55~+150 °C
3.IP Rating (防护级别)	IP 54
4.Diameter of socket end(插合端直径)	φ1.3
5.Testing Voltage (测试电压)	1500V
6.Working Voltage (工作电压)	1350V
7.Rated Current (额定电流)	15A
8.Shell material(壳体材质)	Brass (chromium plating) shell and chuck nut/(nickel plating) pin sleeve and middleware/黄铜(镀铬)外壳和夹头螺母/(镀镍)插销套和中间件
9.Pin Material(插针材料)	Copper alloy gold plating(铜合金镀金)
10.Insulator material(绝缘体材质)	L:PPS P:PEEK

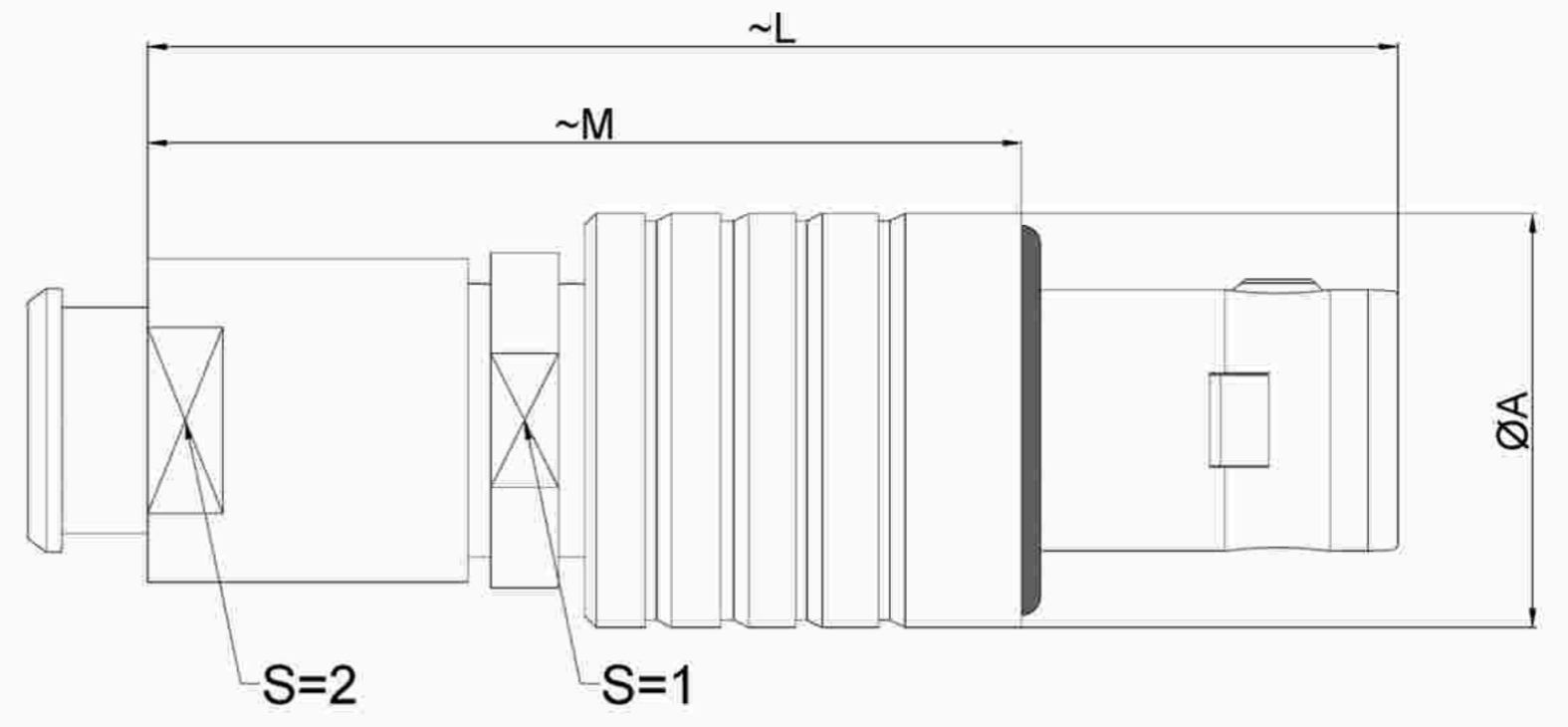

	A	L	M	S1	S2
MM	φ13.5	42	33	10.0	9
in	0.5315	1.6535	1.2992	0.3937	0.3543

Sum up(总结)

Series(系列)	B
Shell style/model (外壳样式/型号)	TEG: Straight plug, cable collet, front seal and nut for fitting a bend relief (IP 54 when mated) 直塞、电缆夹头、前密封件和用于安装弯曲凸起(配对时IP54)
Button (按键)	A button(一个按键)
Termination type (终止类型)	Male solder(公焊锡)
Line diameter awg(线材直径)	28-20AWG
Cable diameterφ (电缆直径)	φ6.3-7.2MM
Matching parts(配件)	ZGG.1B.P02.CXL

Location pin combination(定位销组合)

(编号) Number	Number of positioning pins(定位销数量)	Angle(角度)	Series(系列)--1B
G	One(1)		(Zero degrees)0°
A	Two(2)	A	Thirty degrees(30°)
B	Two(2)		Sixty degrees(60°)
C	Two(2)		Ninety degrees(90°)
D	Two(2)	β	135 degrees(135°)
E	Two(2)		145 degrees(145°)
F	Two(2)		155 degrees(155°)
J	Two(2)	Y	Forty-five degrees(45°)
K	Two(2)		Seventy degrees(70°)
L	Two(2)		80 degrees(80°)

	A	B	C√	ANGLE	
5-10	±0.02	±0.05	±0.1	0°-30°	±0.1°
50-100	±0.1	±0.15	±0.2	61°-90°	±0.5°
50-100	±0.15	±0.2	±0.25		
100-	±0.15%	±0.20%	±0.25%		

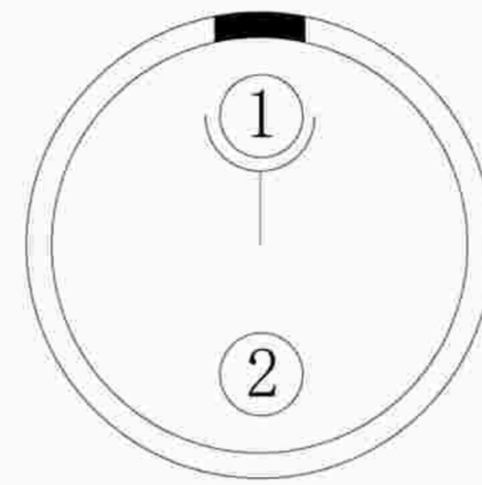

Welded surface (焊接面)

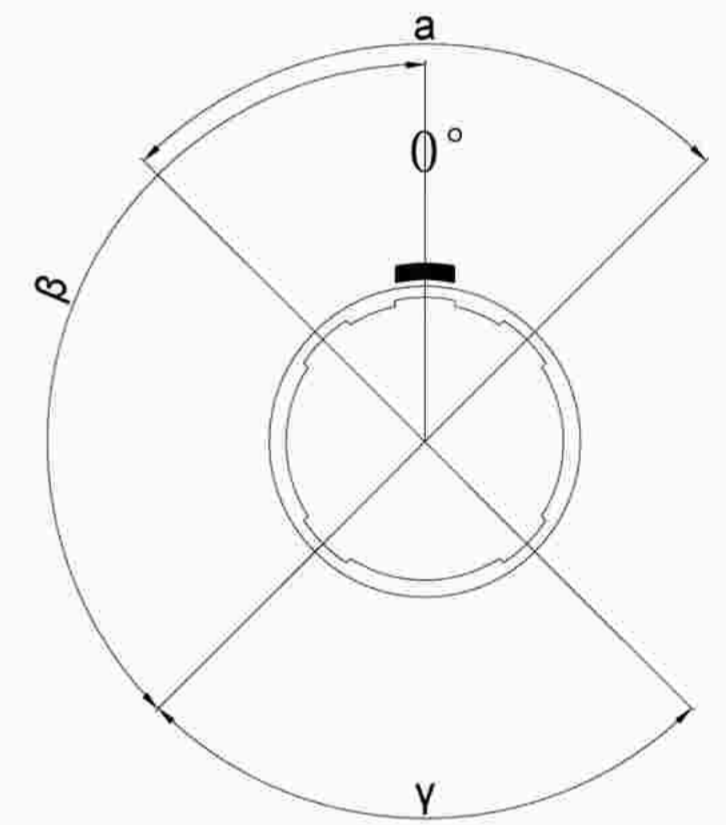

Positive view (正视图)

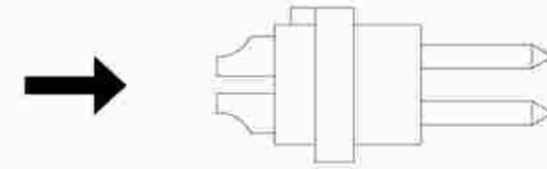

Solder core (焊接型公胶芯)

TE G. 1B. P02.C X A D 72 H

Model(型号)

Positioning pin(定位销)

Series(系列)

Needle core configuration(针芯配置)

Outer casing(外壳)

Insulator(绝缘体)

Needle core(针芯)

Type of CXamp(线夹类型)

Cable diameter(电缆直径)

SH means a sheath type, not a cover type.
(H表示护套型, 不表示为不带护套型)

DESIGNED(设计)
广东星坤科技股份有限公司
CHECKED(校对)
APPROVED(审核)
日期
REVISIONS
文件工程章
www.helloxkb.com www.helloxkb.cn

DATE(日期)	
DATE(日期)	
DATE(日期)	

SCALE(比例)	N/A(不适用)
VIEW(视图)	
UNIT(单位)	MM
MATERIAL (材料)	

MODEL TYPE		
型号类型: TEG.1B.P02.CXAD72H		
PART NO.	1B2-core plug	
名称:	1B2芯插头	
DWG NO.:		
WEIGHT(重量)	SHEET(表)	REVISION(修订)
	1/1	A0