

2 Mbit (256 K × 8) Serial (SPI) F-RAM

serial (SPI), 256K × 8, 25 MHz, industrial

Features

- 2-Mbit ferroelectric random access memory (F-RAM) logically organized as 256 K × 8
 - High-endurance 100 trillion (10^{14}) read/writes
 - 151-year data retention (See [Table 12](#))
 - No delay writes
 - Advanced high-reliability ferroelectric process
- Very fast SPI
 - Up to 25 MHz frequency
 - Direct hardware replacement for serial flash and EEPROM
 - Supports SPI Mode 0 (0, 0) and Mode 3 (1, 1)
- Sophisticated write protection scheme
 - Hardware protection using the Write Protect ($\overline{\text{WP}}$) pin
 - Software protection using Write Disable instruction
 - Software block protection for 1/4, 1/2, or entire array
- Device ID
 - Manufacturer ID and product ID
- Low power consumption
 - 800 μA active current at 1 MHz
 - 100 μA (typ) standby current
 - 3 μA sleep mode current
- Low-voltage operation: $V_{\text{DD}} = 2.0 \text{ V to } 3.6 \text{ V}$
- Industrial temperature: $-40^\circ\text{C to } +85^\circ\text{C}$
- 8-pin plastic dual in-line (PDIP) package
- Restriction of hazardous substances (RoHS) compliant

Functional overview

The FM25V20A (PDIP) is a 2-Mbit nonvolatile memory employing an advanced ferroelectric process. A ferroelectric random access memory or F-RAM is nonvolatile and performs reads and writes similar to a RAM. It provides reliable data retention for 151 years while eliminating the complexities, overhead, and system-level reliability problems caused by serial flash, EEPROM, and other nonvolatile memories.

Unlike serial flash and EEPROM, the FM25V20A (PDIP) performs write operations at bus speed. No write delays are incurred. Data is written to the memory array immediately after each byte is successfully transferred to the device. The next bus cycle can commence without the need for data polling. In addition, the product offers substantial write endurance compared with other nonvolatile memories. The FM25V20A (PDIP) is capable of supporting 10^{14} read/write cycles, or 100 million times more write cycles than EEPROM.

These capabilities make the FM25V20A (PDIP) ideal for nonvolatile memory applications, requiring frequent or rapid writes. Examples range from data collection, where the number of write cycles may be critical, to demanding industrial controls where the long write time of serial flash or EEPROM can cause data loss.

The FM25V20A (PDIP) provides substantial benefits to users of serial EEPROM or flash as a hardware drop-in replacement. The FM25V20A (PDIP) uses the high-speed SPI bus, which enhances the high-speed write capability of F-RAM technology. The device incorporates a read-only Device ID that allows the host to determine the manufacturer, product density, and product revision. The device specifications are guaranteed over an industrial temperature range of $-40^\circ\text{C to } +85^\circ\text{C}$.

2 Mbit (256 K × 8) Serial (SPI) F-RAM

serial (SPI), 256K × 8, 25 MHz, industrial



Block diagram

Block diagram

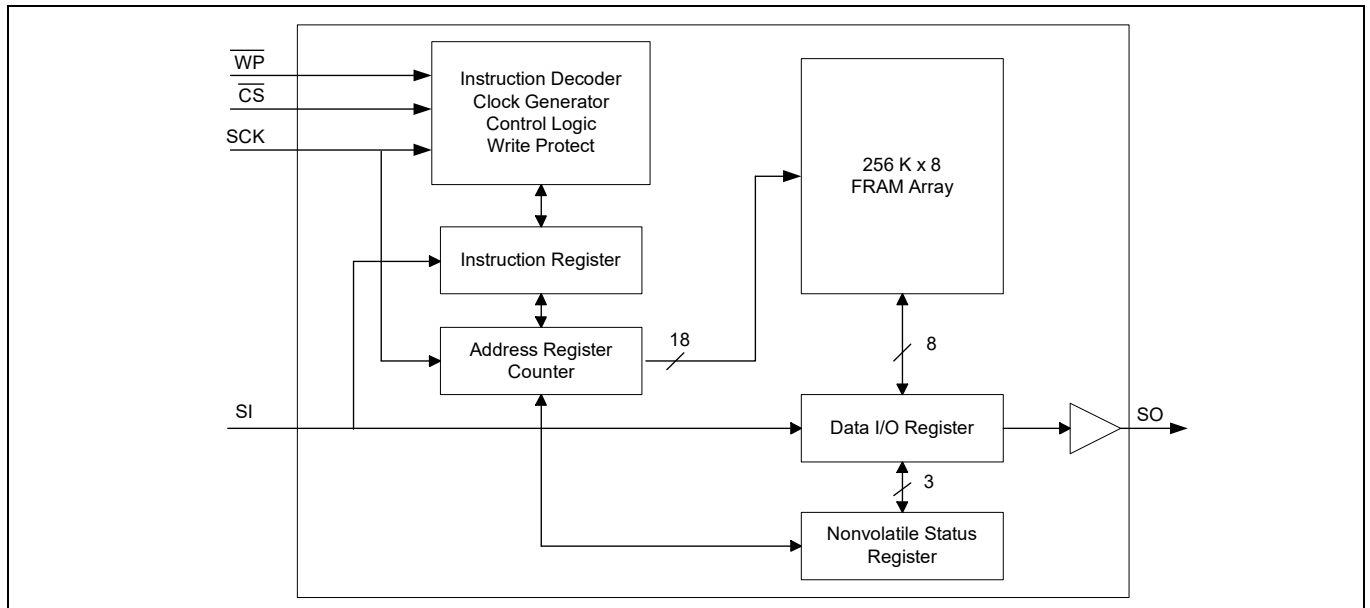

Table of contents

Features	1
Functional overview	1
Block diagram	2
Table of contents	3
1 Pinout	4
2 Pin definition	5
3 Overview	6
3.1 Memory architecture	6
3.2 Serial peripheral interface – SPI bus	6
3.3 SPI overview	6
3.3.1 SPI master	6
3.3.2 SPI slave	6
3.3.3 Chip Select (CS)	7
3.3.4 Serial Clock (SCK)	7
3.3.5 Data transmission (SI/SO)	7
3.3.6 Most significant bit (MSB)	8
3.3.7 Serial opcode	8
3.3.8 Invalid opcode	8
3.3.9 Status Register	8
3.4 SPI modes	9
3.5 Power up to first access	9
3.6 Command structure	10
3.7 WREN - Set write enable latch	10
3.8 WRDI - Reset write enable latch	11
4 Status Register and write protection	12
4.1 RDSR - Read Status Register	13
4.2 WRSR - Write Status Register	13
5 Memory operation	14
5.1 Write operation	14
5.2 Read operation	14
5.3 Fast read operation	14
5.4 Sleep mode	15
5.5 Device ID	16
5.6 Endurance	17
6 Maximum ratings	18
7 Operating range	19
8 DC electrical characteristics	20
9 Data retention and endurance	21
10 Capacitance	22
11 Thermal resistance	23
12 AC test conditions	24
13 AC switching characteristics	25
14 Power cycle timing	26
15 Ordering information	27
15.1 Ordering code definitions	27
16 Package diagram	28
17 Acronyms	29
18 Document conventions	30
18.1 Units of measure	30
Revision history	31

Pinout

1 Pinout

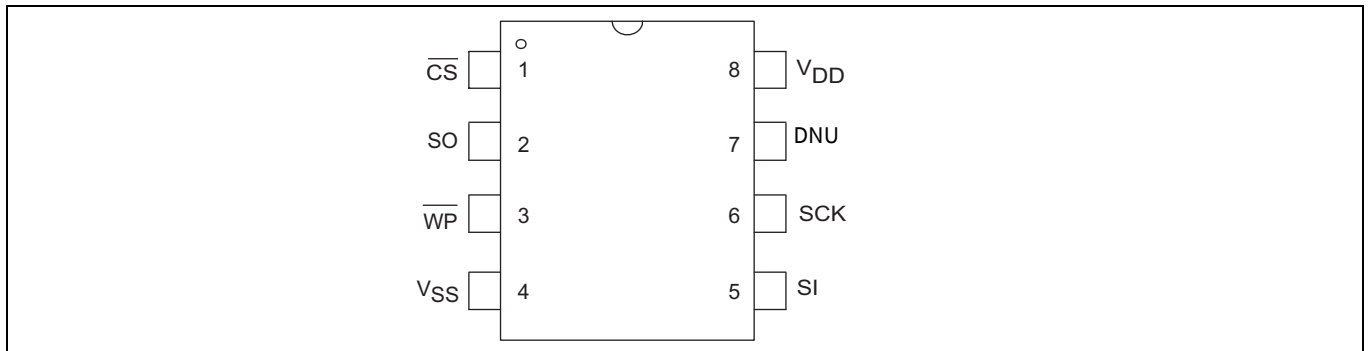

Figure 1 8-pin PDIP pinout

2 Pin definition

Table 1 Pin definitions

Pin name	I/O type	Description
CS	Input	Chip Select. This active LOW input activates the device. When HIGH, the device enters low-power standby mode, ignores other inputs, and the output is tristated. When LOW, the device internally activates the SCK signal. A falling edge on \overline{CS} must occur before every opcode.
SCK	Input	Serial Clock. All I/O activity is synchronized to the serial clock. Inputs are latched on the rising edge and outputs occur on the falling edge. Because the device is synchronous, the clock frequency may be any value between 0 and 25 MHz and may be interrupted at any time.
SI ^[1]	Input	Serial Input. All data is input to the device on this pin. The pin is sampled on the rising edge of SCK and is ignored at other times. It should always be driven to a valid logic level to meet IDD specifications.
SO ^[1]	Output	Serial Output. This is the data output pin. It is driven during a read and remains tristated at all other times. Data transitions are driven on the falling edge of the serial clock.
\overline{WP}	Input	Write Protect. This Active LOW pin prevents write operation to the Status Register when WPEN is set to '1'. This is critical because other write protection features are controlled through the Status Register. A complete explanation of write protection is provided in the Status Register and write protection section. This pin must be tied to V_{DD} if not used.
DNU	Do Not Use	Do Not Use. This pin must be tied to VDD.
V_{SS}	Power supply	Ground for the device. Must be connected to the ground of the system.
V_{DD}	Power supply	Power supply input to the device.

Note

1. SI may be connected to SO for a single pin data interface.

3 Overview

The FM25V20A (PDIP) is a serial F-RAM memory. The memory array is logically organized as 262, 144 × 8 bits and is accessed using an industry-standard SPI bus. The functional operation of the F-RAM is similar to serial flash and serial EEPROMs. The major difference between the FM25V20A (PDIP) and a serial flash or EEPROM with the same pinout is the F-RAM's superior write performance, high endurance, and low power consumption.

3.1 Memory architecture

When accessing the FM25V20A (PDIP), the user addresses 256K locations of eight data bits each. These eight data bits are shifted in or out serially. The addresses are accessed using the SPI protocol, which includes a chip select (to permit multiple devices on the bus), an opcode, and a three-byte address. The upper 6 bits of the address range are 'don't care' values. The complete address of 18 bits specifies each byte address uniquely.

Most functions of the FM25V20A (PDIP) are either controlled by the SPI interface or handled by on-board circuitry. The access time for the memory operation is essentially zero, beyond the time needed for the serial protocol. That is, the memory is read or written at the speed of the SPI bus. Unlike a serial flash or EEPROM, it is not necessary to poll the device for a ready condition because writes occur at bus speed. By the time a new bus transaction can be shifted into the device, a write operation is complete. This is explained in more detail in the interface section.

3.2 Serial peripheral interface – SPI bus

The FM25V20A (PDIP) is a SPI slave device and operates at speeds up to 25 MHz. This high-speed serial bus provides high-performance serial communication to a SPI master. Many common microcontrollers have hardware SPI ports allowing a direct interface. It is quite simple to emulate the port using ordinary port pins for microcontrollers that do not. The FM25V20A (PDIP) operates in SPI Mode 0 and 3.

3.3 SPI overview

The SPI is a four-pin interface with Chip Select (\overline{CS}), Serial Input (SI), Serial Output (SO), and Serial Clock (SCK) pins.

The SPI is a synchronous serial interface, which uses clock and data pins for memory access and supports multiple devices on the data bus. A device on the SPI bus is activated using the \overline{CS} pin.

The relationship between chip select, clock, and data is dictated by the SPI mode. This device supports SPI modes 0 and 3. In both of these modes, data is clocked into the F-RAM on the rising edge of SCK starting from the first rising edge after \overline{CS} goes active.

The SPI protocol is controlled by opcodes. These opcodes specify the commands from the bus master to the slave device. After \overline{CS} is activated, the first byte transferred from the bus master is the opcode. Following the opcode, any addresses and data are then transferred. The \overline{CS} must go inactive after an operation is complete and before a new opcode can be issued. The commonly used terms in the SPI protocol are as follows:

3.3.1 SPI master

The SPI master device controls the operations on a SPI bus. An SPI bus may have only one master with one or more slave devices. All the slaves share the same SPI bus lines and the master may select any of the slave devices using the \overline{CS} pin. All of the operations must be initiated by the master activating a slave device by pulling the \overline{CS} pin of the slave LOW. The master also generates the SCK and all the data transmission on SI and SO lines are synchronized with this clock.

3.3.2 SPI slave

The SPI slave device is activated by the master through the Chip Select line. A slave device gets the SCK as an input from the SPI master and all the communication is synchronized with this clock. An SPI slave never initiates a communication on the SPI bus and acts only on the instruction from the master.

The FM25V20A (PDIP) operates as an SPI slave and may share the SPI bus with other SPI slave devices.

3.3.3 Chip Select ($\overline{\text{CS}}$)

To select any slave device, the master needs to pull down the corresponding $\overline{\text{CS}}$ pin. Any instruction can be issued to a slave device only while the $\overline{\text{CS}}$ pin is LOW. When the device is not selected, data through the SI pin is ignored and the serial output pin (SO) remains in a high-impedance state.

Note: A new instruction must begin with the falling edge of $\overline{\text{CS}}$. Therefore, only one opcode can be issued for each active chip select cycle.

3.3.4 Serial Clock (SCK)

The Serial Clock is generated by the SPI master and the communication is synchronized with this clock after $\overline{\text{CS}}$ goes LOW.

The FM25V20A (PDIP) enables SPI modes 0 and 3 for data communication. In both of these modes, the inputs are latched by the slave device on the rising edge of SCK and outputs are issued on the falling edge. Therefore, the first rising edge of SCK signifies the arrival of the first bit (MSB) of a SPI instruction on the SI pin. Further, all data inputs and outputs are synchronized with SCK.

3.3.5 Data transmission (SI/SO)

The SPI data bus consists of two lines, SI and SO, for serial data communication. SI is also referred to as master out slave in (MOSI) and SO is referred to as master in slave out (MISO). The master issues instructions to the slave through the SI pin, while the slave responds through the SO pin. Multiple slave devices may share the SI and SO lines as described earlier.

The FM25V20A (PDIP) has two separate pins for SI and SO, which can be connected with the master as shown in [Figure 2](#).

For a microcontroller that has no dedicated SPI bus, a general-purpose port may be used. To reduce hardware resources on the controller, it is possible to connect the two data pins (SI, SO) together and tie off (HIGH) the $\overline{\text{WP}}$ pin. [Figure 3](#) shows such a configuration, which uses only three pins.

3.3.6 Most significant bit (MSB)

The SPI protocol requires that the first bit to be transmitted is the Most Significant Bit (MSB). This is valid for both address and data transmission.

The 2-Mbit serial F-RAM requires a 3-byte address for any read or write operation. Because the address is only 18 bits, the first six bits, which are fed in are ignored by the device. Although these six bits are ‘don’t care’, Infineon® recommends that these bits be set to 0s to enable seamless transition to higher memory densities.

3.3.7 Serial opcode

After the slave device is selected with \overline{CS} going LOW, the first byte received is treated as the opcode for the intended operation. FM25V20A (PDIP) uses the standard opcodes for memory accesses.

3.3.8 Invalid opcode

If an invalid opcode is received, the opcode is ignored and the device ignores any additional serial data on the SI pin until the next falling edge of \overline{CS} , and the SO pin remains tristated.

3.3.9 Status Register

FM25V20A (PDIP) has an 8-bit Status Register. The bits in the Status Register are used to configure the device. These bits are described in [Table 4](#).

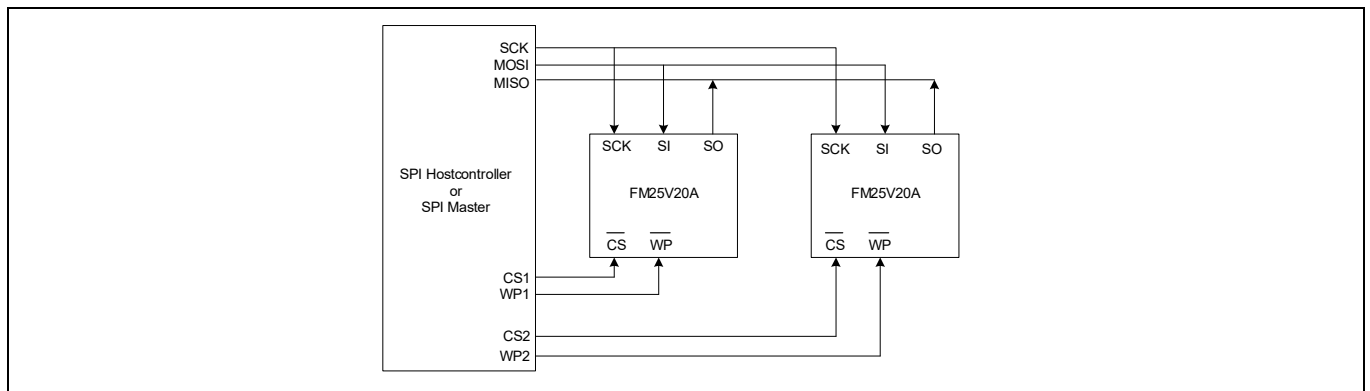

Figure 2 System configuration with SPI port

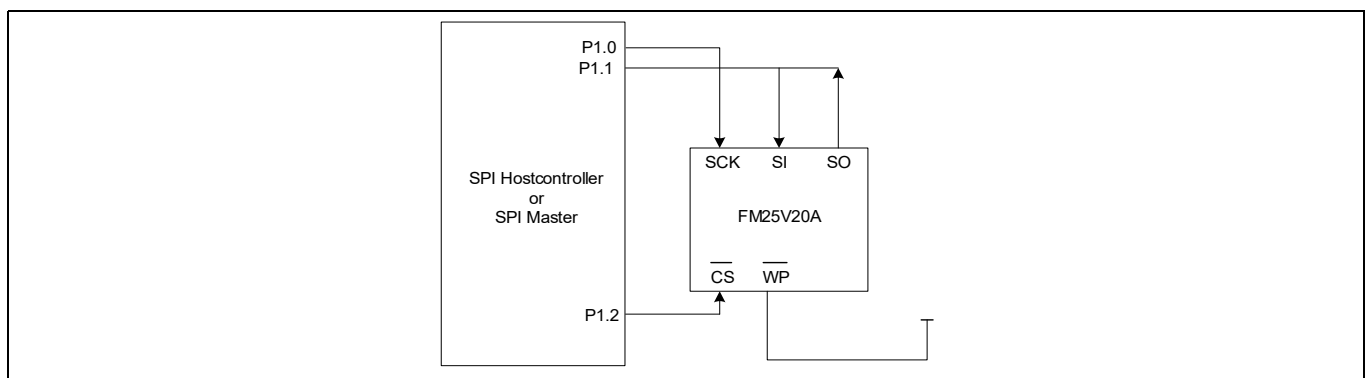

Figure 3 System configuration without SPI port

3.4 SPI modes

FM25V20A (PDIP) may be driven by a microcontroller with its SPI peripheral running in either of the following modes:

- SPI Mode 0 (CPOL = 0, CPHA = 0)
- SPI Mode 3 (CPOL = 1, CPHA = 1)

For both these modes, the input data is latched in on the rising edge of SCK starting from the first rising edge after \overline{CS} goes active. If the clock starts from a HIGH state (in mode 3), the first rising edge after the clock toggles is considered. The output data is available on the falling edge of SCK.

The two SPI modes are shown in **Figure 4** and **Figure 5**. The status of the clock when the bus master is not transferring data is:

- SCK remains at 0 for Mode 0
- SCK remains at 1 for Mode 3

The device detects the SPI mode from the status of the SCK pin when the device is selected by bringing the \overline{CS} pin LOW. If the SCK pin is LOW when the device is selected, SPI Mode 0 is assumed and if the SCK pin is HIGH, it works in SPI Mode 3.

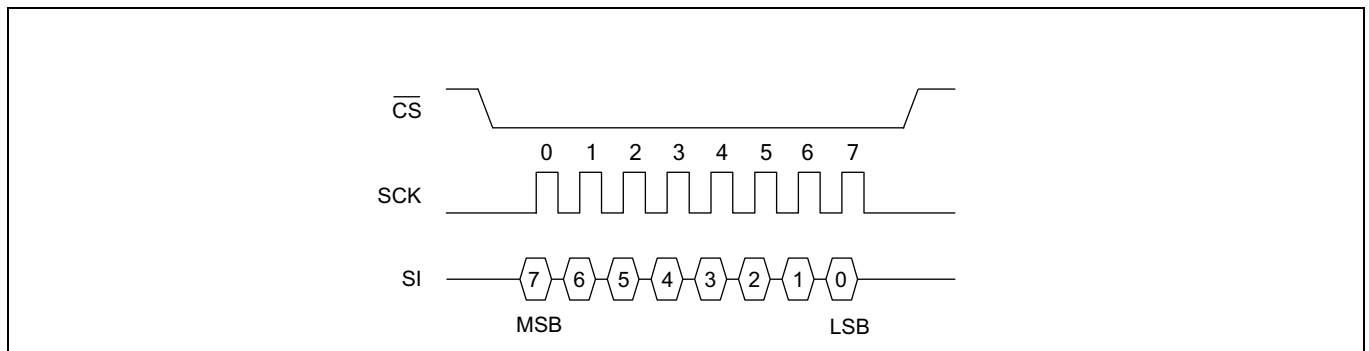

Figure 4 SPI Mode 0

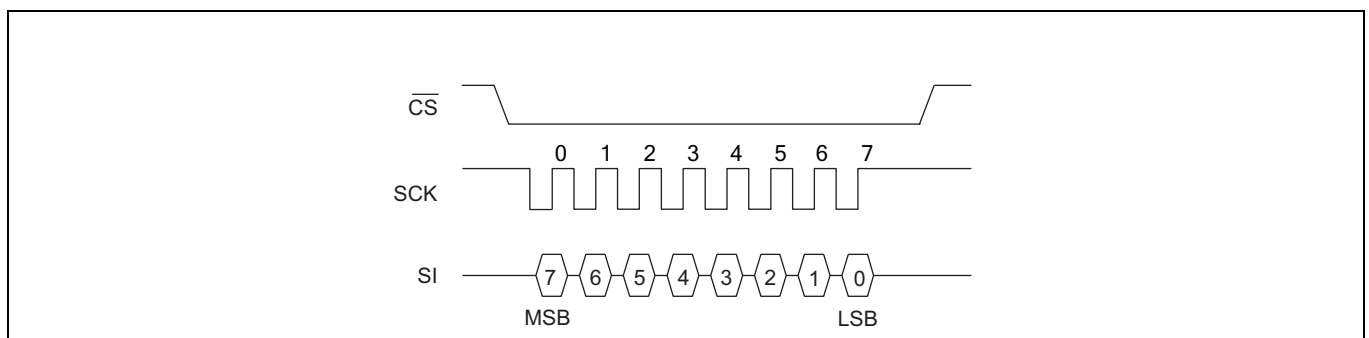

Figure 5 SPI Mode 3

3.5 Power up to first access

The FM25V20 is not accessible for a t_{PU} time after power-up. Users must comply with the timing parameter, t_{PU} , which is the minimum time from V_{DD} (min) to the first \overline{CS} LOW.

3.6 Command structure

There are nine commands, called opcodes, that can be issued by the bus master to the FM25V20A (PDIP). They are listed in [Table 2](#). These opcodes control the functions performed by the memory.

Table 2 Opcode commands

Name	Description	Opcode
WREN	Set write enable latch	0000 0110b
WRDI	Reset write enable latch	0000 0100b
RDSR	Read Status Register	0000 0101b
WRSR	Write Status Register	0000 0001b
READ	Read memory data	0000 0011b
FSTRD	Fast read memory data	0000 1011b
WRITE	Write memory data	0000 0010b
SLEEP	Enter sleep mode	1011 1001b
RDID	Read device ID	1001 1111b

3.7 WREN - Set write enable latch

The FM25V20A (PDIP) will power up with writes disabled. The WREN command must be issued before any write operation. Sending the WREN opcode allows the user to issue subsequent opcodes for write operations. These include writing the Status Register (WRSR) and writing the memory (WRITE).

Sending the WREN opcode causes the internal Write Enable Latch to be set. A flag bit in the Status Register, called WEL, indicates the state of the latch. WEL = 1 indicates that writes are permitted. Attempting to write the WEL bit in the Status Register has no effect on the state of this bit – only the WREN opcode can set this bit. The WEL bit will be automatically cleared on the rising edge of CS following a WRDI, a WRSR, or a WRITE operation. This prevents further writes to the Status Register or the F-RAM array without another WREN command. [Figure 6](#) illustrates the WREN command bus configuration.

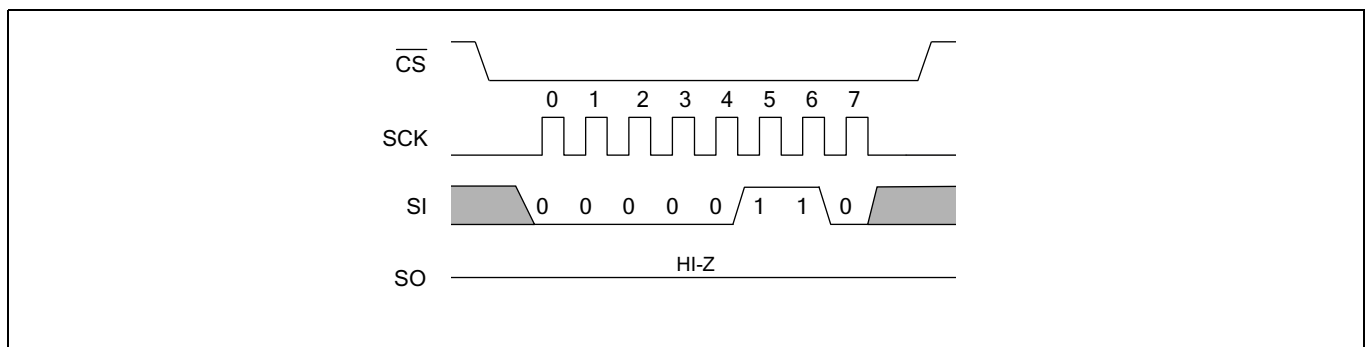

Figure 6 WREN bus configuration

3.8 WRDI - Reset write enable latch

The WRDI command disables all write activity by clearing the Write Enable Latch. The user can verify that writes are disabled by reading the WEL bit in the Status Register and verifying that WEL is equal to '0'. [Figure 7](#) illustrates the WRDI command bus configuration.

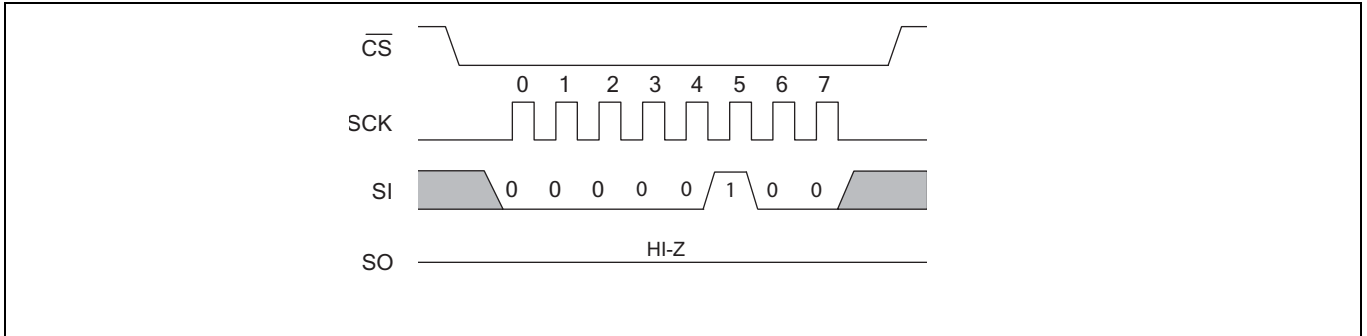

Figure 7 WRDI bus configuration

4 Status Register and write protection

The write protection features of the FM25V20A (PDIP) are multi-tiered and are enabled through the status register. The Status Register is organized as follows. (The default value shipped from the factory for WEL, BP0, BP1, bits 4–5, WPEN is ‘0’, and for bit 6 is ‘1’).

Table 3 Status Register

Bit 7	Bit 6	Bit 5	Bit 4	Bit 3	Bit 2	Bit 1	Bit 0
WPEN (0)	X (1)	X (0)	X (0)	BP1 (0)	BP0 (0)	WEL (0)	X (0)

Table 4 Status Register bit definition

Bit	Definition	Description
Bit 0	Don't care	This bit is non-writable and always returns ‘0’ upon read.
Bit 1 (WEL)	Write Enable	WEL indicates if the device is write enabled. This bit defaults to ‘0’ (disabled) on power-up. WEL = 1 --> Write enabled WEL = 0 --> Write disabled
Bit 2 (BP0)	Block Protect bit ‘0’	Used for block protection. For details, see Table 5 .
Bit 3 (BP1)	Block Protect bit ‘1’	Used for block protection. For details, see Table 5 .
Bit 4-5	Don't care	These bits are non-writable and always return ‘0’ upon read.
Bit 6	Don't care	This bit is non-writable and always returns ‘1’ upon read.
Bit 7 (WPEN)	Write Protect Enable bit	Used to enable the function of Write Protect Pin (WP). For details, see Table 6 .

Bits 0 and 4-5 are fixed at ‘0’ and bit 6 is fixed at ‘1’; none of these bits can be modified. Note that bit 0 (“Ready or Write in progress” bit in serial flash and EEPROM) is unnecessary, as the F-RAM writes in real-time and is never busy, so it reads out as a ‘0’. An exception to this is when the device is waking up from sleep mode, which is described in the [Sleep mode](#) section. The BP1 and BP0 control the software write-protection features and are nonvolatile bits. The WEL flag indicates the state of the Write Enable Latch. Attempting to directly write the WEL bit in the Status Register has no effect on its state. This bit is internally set and cleared via the WREN and WRDI commands, respectively.

BP1 and BP0 are memory block write protection bits. They specify portions of memory that are write-protected as shown in [Table 5](#).

Table 5 Block memory write protection

BP1	BP0	Protected address range
0	0	None
0	1	30000h to 3FFFFh (upper 1/4)
1	0	20000h to 3FFFFh (upper 1/2)
1	1	00000h to 3FFFFh (all)

The BP1 and BP0 bits and the Write Enable Latch are the only mechanisms that protect the memory from writes. The remaining write protection features protect inadvertent changes to the block protect bits.

The write protect enable bit (WPEN) in the Status Register controls the effect of the hardware write protect (\overline{WP}) pin. When the WPEN bit is set to ‘0’, the status of the \overline{WP} pin is ignored. When the WPEN bit is set to ‘1’, a LOW on the \overline{WP} pin inhibits a write to the Status Register. Thus the Status Register is write-protected only when WPEN = 1 and \overline{WP} = 0.

Table 6 summarizes the write protection conditions.

Table 6 Write protection

WEL	WPEN	WP	Protected blocks	Unprotected blocks	Status Register
0	X	X	Protected	Protected	Protected
1	0	X	Protected	Unprotected	Unprotected
1	1	0	Protected	Unprotected	Protected
1	1	1	Protected	Unprotected	Unprotected

4.1 RDSR - Read Status Register

The RDSR command allows the bus master to verify the contents of the Status Register. Reading the status register provides information about the current state of the write-protection features. Following the RDSR opcode, the FM25V20A (PDIP) will return one byte with the contents of the Status Register.

4.2 WRSR - Write Status Register

The WRSR command allows the SPI bus master to write into the Status Register and change the write protect configuration by setting the WPEN, BP0 and BP1 bits as required. Before issuing a WRSR command, the WP pin must be HIGH or inactive. Note that on the FM25V20A (PDIP), WP only prevents writing to the Status Register, not the memory array. Before sending the WRSR command, the user must send a WREN command to enable writes. Executing a WRSR command is a write operation and therefore, clears the Write Enable Latch.

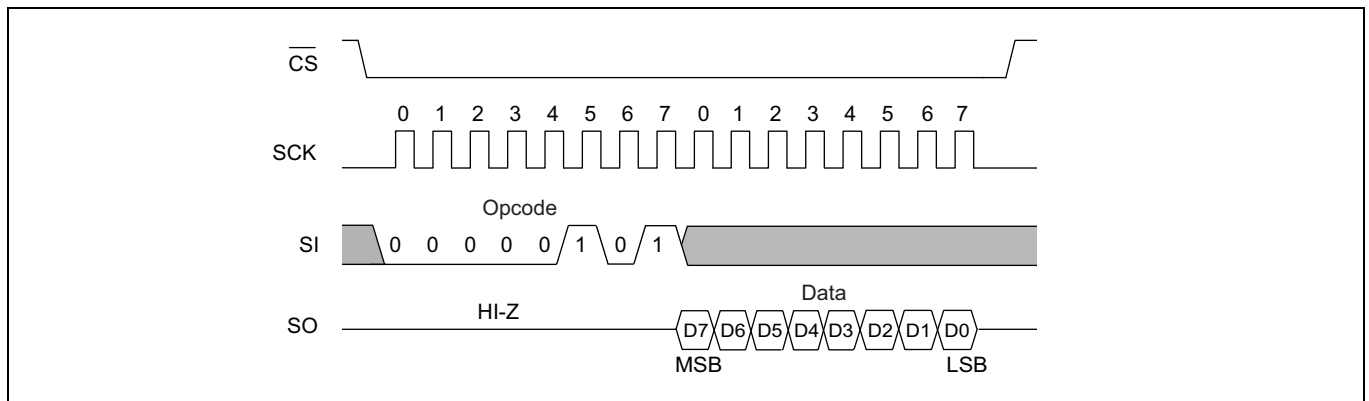

Figure 8 RDSR bus configuration

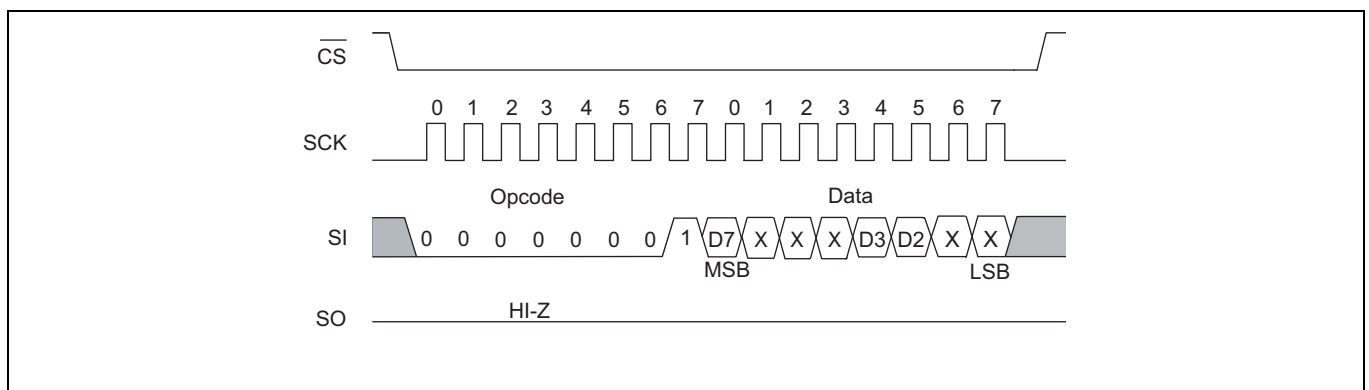

Figure 9 WRSR bus configuration (WREN not shown)

5 Memory operation

The SPI interface, which is capable of a high clock frequency, highlights the fast write capability of the F-RAM technology. Unlike serial flash and EEPROMs, the FM25V20A (PDIP) can perform sequential writes at bus speed. No page register is needed and any number of sequential writes may be performed.

5.1 Write operation

All writes to the memory begin with a WREN opcode with \overline{CS} being asserted and deasserted. The next opcode is WRITE. The WRITE opcode is followed by a three-byte address containing the 18-bit address (A17-A0) of the first data byte to be written into the memory. The upper six bits of the three-byte address are ignored. Subsequent bytes are data bytes, which are written sequentially. Addresses are incremented internally as long as the bus master continues to issue clocks and keeps CS LOW. If the last address of 3FFFFh is reached, the counter will roll over to 00000h. Data is written MSB first. The rising edge of CS terminates a write operation. A write operation is shown in [Figure 10](#).

Note: When a burst write reaches a protected block address, the automatic address increment stops and all the subsequent data bytes received for write will be ignored by the device.

EEPROMs use page buffers to increase their write throughput. This compensates for the technology's inherently slow write operations. F-RAM memories do not have page buffers because each byte is written to the F-RAM array immediately after it is clocked in (after the eighth clock). This allows any number of bytes to be written without page buffer delays.

Note: If the power is lost in the middle of the write operation, only the last completed byte will be written.

5.2 Read operation

After the falling edge of \overline{CS} , the bus master can issue a READ opcode. Following the READ command is a three-byte address containing the 18-bit address (A17-A0) of the first byte of the read operation. The upper six bits of the address are ignored. After the opcode and address are issued, the device drives out the read data on the next eight clocks. The SI input is ignored during read data bytes. Subsequent bytes are data bytes, which are read out sequentially. Addresses are incremented internally as long as the bus master continues to issue clocks and CS is LOW. If the last address of 3FFFFh is reached, the counter will roll over to 00000h. Data is read MSB first. The rising edge of CS terminates a read operation and tristates the SO pin. A read operation is shown in [Figure 11](#).

5.3 Fast read operation

The FM25V20A (PDIP) supports a FAST READ opcode (0Bh) that is provided for code compatibility with serial flash devices. The FAST READ opcode is followed by a three-byte address containing the 18-bit address (A17-A0) of the first byte of the read operation and then a dummy byte. The dummy byte inserts a read latency of 8-clock cycle. The fast read operation is otherwise the same as an ordinary read operation except that it requires an additional dummy byte. After receiving opcode, address, and a dummy byte, the FM25V20A (PDIP) starts driving its SO line with data bytes, with MSB first, and continues transmitting as long as the device is selected and the clock is available. In case of bulk read, the internal address counter is incremented automatically, and after the last address 3FFFFh is reached, the counter rolls over to 00000h. When the device is driving data on its SO line, any transition on its SI line is ignored. The rising edge of CS terminates a fast read operation and tristates the SO pin. A fast read operation is shown in [Figure 12](#).

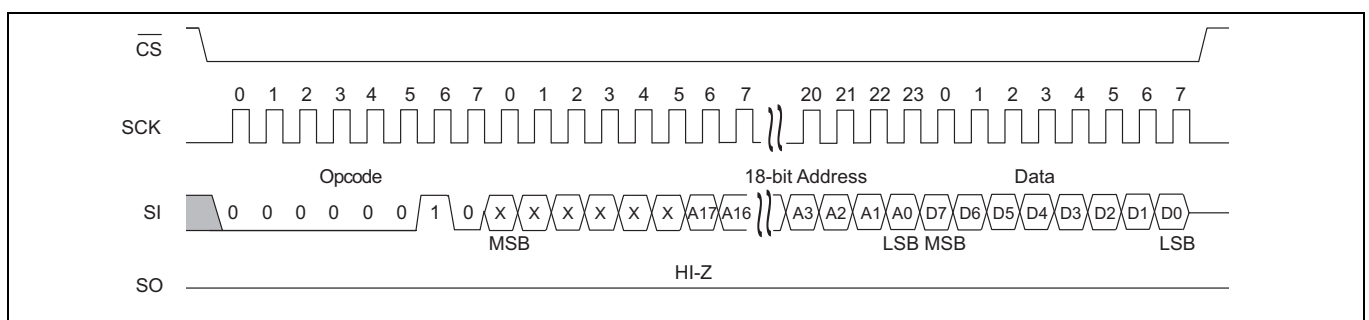

Figure 10 Memory write (WREN not shown) operation

Memory operation

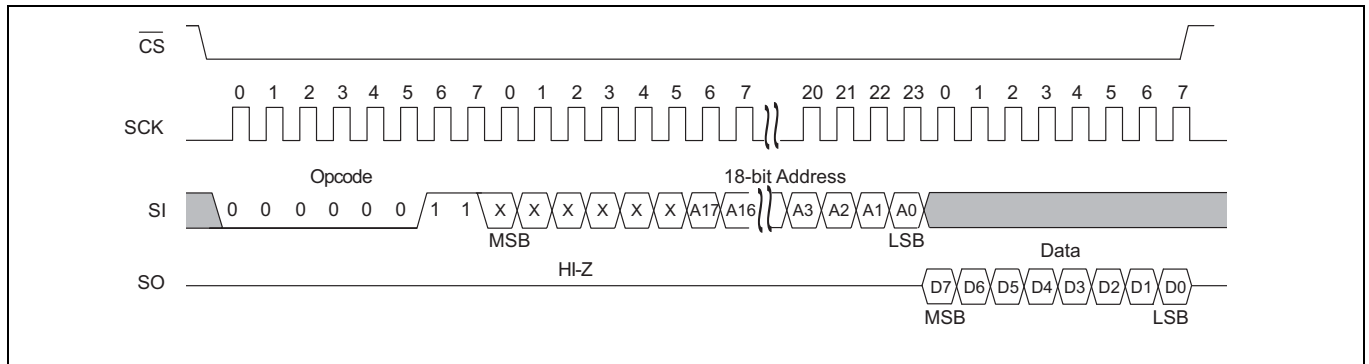

Figure 11 Memory read operation

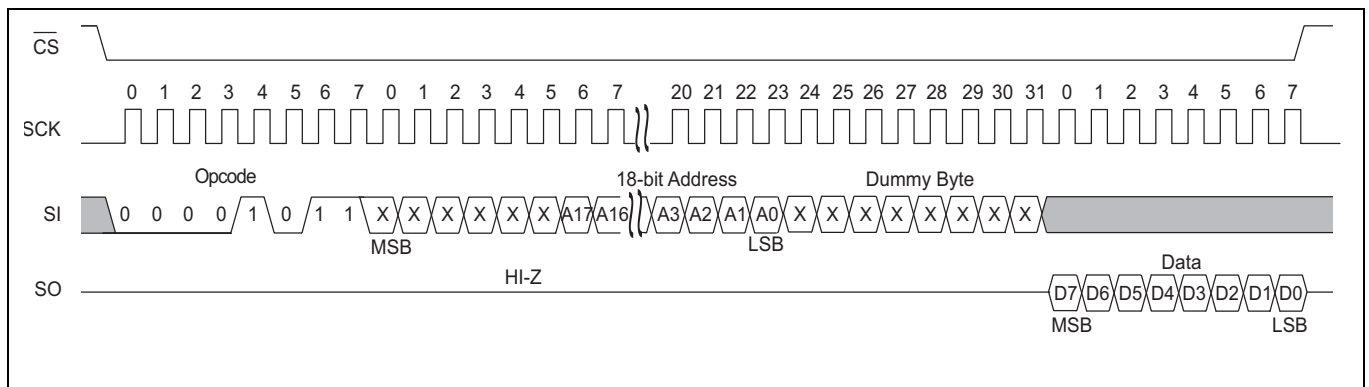

Figure 12 Fast read operation

5.4 Sleep mode

A low-power sleep mode is implemented on the FM25V20 device. The device will enter the low-power state when the SLEEP opcode B9h is clocked in and a rising edge of \overline{CS} is applied. When in sleep mode, the SCK and SI pins are ignored and SO will be HI-Z, but the device continues to monitor the \overline{CS} pin. On the next falling edge of \overline{CS} , the device will return to normal operation within t_{REC} time. The SO pin remains in a HI-Z state during the wakeup period. The device does not necessarily respond to an opcode within the wakeup period. To start the wakeup procedure, the controller may send a “dummy” read, for example, and wait the remaining t_{REC} time.

Memory operation

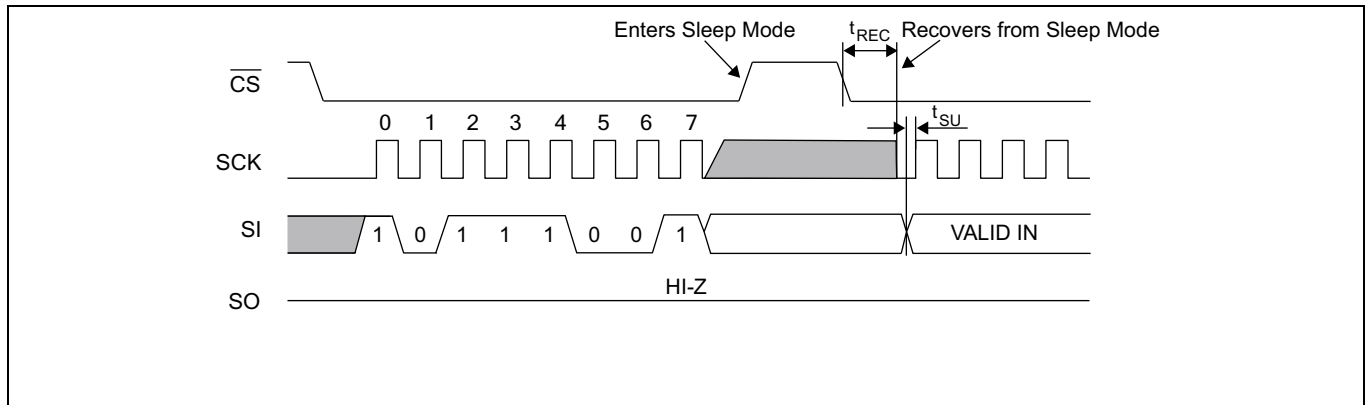

Figure 13 Sleep mode operation

5.5 Device ID

The FM25V20A (PDIP) device can be interrogated for its manufacturer, product identification, and die revision. The RDID opcode 9Fh allows the user to read the manufacturer ID and product ID, both of which are read-only bytes. The JEDEC-assigned manufacturer ID places the Infineon (Ramtron) identifier in bank 7; therefore, there are six bytes of the continuation code 7Fh followed by the single byte C2h. There are two bytes of product ID, which includes a family code, a density code, a sub code, and the product revision code.

Table 7 Device ID

Device ID (9 bytes)	Device ID description					
	71-16 (56 bits)	15-13 (3 bits)	12-8 (5 bits)	7-6 (2 bits)	5-3 (3 bits)	2-0 (3 bits)
	Manufacturer ID	Product ID				
Family		Density	Sub	Rev	Rsvd	
7F7F7F7F7F7FC22508h	0111111101111111011111 1101111111011111101111 111111000010	001	00101	00	001	000

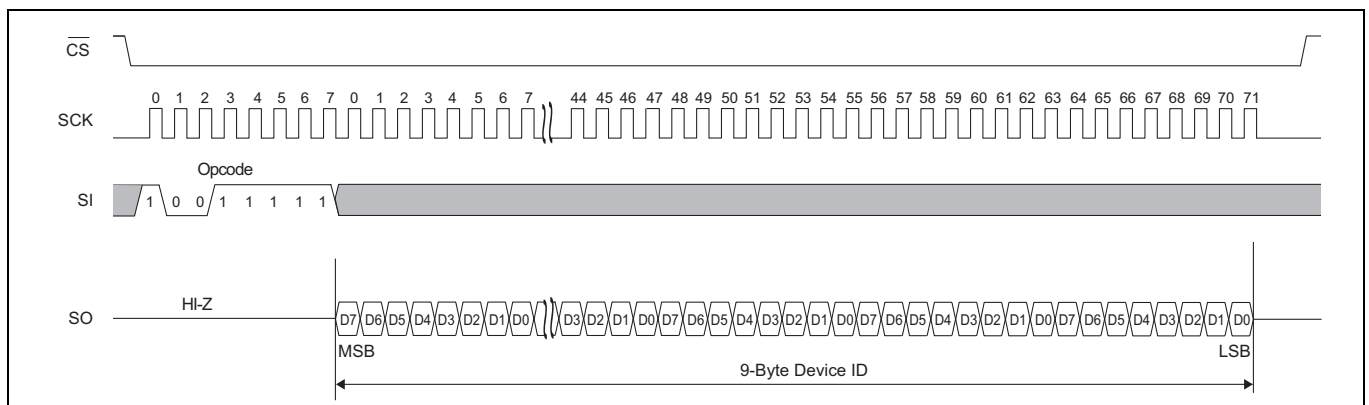

Figure 14 Read device ID

5.6 Endurance

The FM25V20A (PDIP) devices are capable of being accessed at least 10^{14} times, reads or writes. An F-RAM memory operates with a read and restore mechanism. Therefore, an endurance cycle is applied on a row basis for each access (read or write) to the memory array. The F-RAM architecture is based on an array of rows and columns of 32K rows of 64 bits each. The entire row is internally accessed once, whether a single byte or all eight bytes are read or written. Each byte in the row is counted only once in an endurance calculation. **Table 8** shows endurance calculations for a 64 byte repeating loop, which includes an opcode, a starting address, and a sequential 64-byte data stream. This causes each byte to experience one endurance cycle through the loop. F-RAM read and write endurance is virtually unlimited even at a 25 MHz clock rate.

Table 8 Time to reach endurance limit for repeating 64-byte loop

SCK freq (MHz)	Endurance cycles/sec	Endurance cycles/year	Years to reach limit
25	45,950	1.45×10^{12}	69.1
10	18,380	5.79×10^{11}	172.7
5	9,190	2.90×10^{11}	345.4

Maximum ratings

6 Maximum ratings

Exceeding maximum ratings may shorten the useful life of the device. These user guidelines are not tested.

Table 9 Absolute maximum ratings

Parameter	Maximum ratings
Storage temperature	-55°C to +125°C
Maximum accumulated storage time At 125 °C ambient temperature At 85 °C ambient temperature	1000 h 10 years
Ambient temperature with power applied	-55°C to +125°C
Supply voltage on V_{DD} relative to V_{SS}	-1.0 V to +4.5 V
Input voltage	-1.0 V to +4.5 V and $V_{IN} < V_{DD} + 1.0 V$
DC voltage applied to outputs in High-Z state	-0.5 V to $V_{DD} + 0.5 V$
Transient voltage (< 20 ns) on any pin to ground potential	-2.0 V to $V_{DD} + 2.0 V$
Package power dissipation capability ($T_A = 25^\circ\text{C}$)	1.0 W
Surface mount lead soldering temperature (3 seconds)	+260°C
DC output current (1 output at a time, 1s duration)	15 mA
Electrostatic Discharge Voltage Human Body Model (JEDEC Std JESD22-A114-B)	4 kV
Charged Device Model (JEDEC Std JESD22-C101-A)	1.25 kV
Latch-up current	140 mA

Operating range

7 Operating range

Table 10 Operating range

Range	Ambient temperature (T_A)	V_{DD}
Industrial	-40°C to +85°C	2.0 V to 3.6 V

8 DC electrical characteristics

Table 11 DC electrical characteristics

Over the **Operating range**

Parameter	Description	Test conditions	Min	Typ ^[2]	Max	Unit	
V _{DD}	Power supply	–	2.0	3.3	3.6	V	
I _{DD}	V _{DD} supply current	SCK toggling between V _{DD} – 0.2 V and V _{SS} , other inputs V _{SS} or V _{DD} – 0.2 V. SO = Open	f _{SCK} = 1 MHz	–	–	0.80	mA
			f _{SCK} = 25 MHz	–	1.5	2.0	mA
I _{SB}	V _{DD} standby current	CS = V _{DD} . All other inputs V _{SS} or V _{DD} .	T _A = 25°C	–	100	150	μA
			T _A = 85°C	–	–	250	μA
I _{ZZ}	Sleep mode current	CS = V _{DD} . All other inputs V _{SS} or V _{DD} .	T _A = 25°C	–	3	5	μA
			T _A = 85°C	–	–	8	μA
I _{LI}	Input leakage current	V _{SS} ≤ V _{IN} ≤ V _{DD}	–	–	±1	μA	
I _{LO}	Output leakage current	V _{SS} ≤ V _{OUT} ≤ V _{DD}	–	–	±1	μA	
V _{IH}	Input HIGH voltage	–	0.7 × V _{DD}	–	V _{DD} + 0.3	V	
V _{IL}	Input LOW voltage	–	– 0.3	–	0.3 × V _{DD}	V	
V _{OH1}	Output HIGH voltage	I _{OH} = –1 mA, V _{DD} = 2.7 V	2.4	–	–	V	
V _{OH2}	Output HIGH voltage	I _{OH} = –100 μA	V _{DD} – 0.2	–	–	V	
V _{OL1}	Output LOW voltage	I _{OL} = 2 mA, V _{DD} = 2.7 V	–	–	0.4	V	
V _{OL2}	Output LOW voltage	I _{OL} = 150 μA	–	–	0.2	V	

Note

2. Typical values are at 25°C, V_{DD} = V_{DD}(typ). Not 100% tested.

Data retention and endurance

9 Data retention and endurance

Table 12 Data retention and endurance

Parameter	Description	Test condition	Min	Max	Unit
T _{DR}	Data retention	T _A = 85°C	10	–	Years
		T _A = 75°C	38	–	Years
		T _A = 65°C	151	–	Years
NV _C	Endurance	Over operating temperature	10 ¹⁴	–	Cycles

Capacitance

10 Capacitance

Table 13 Capacitance

Parameter ^[3]	Description	Test conditions	Max	Unit
C _O	Output pin capacitance (SO)	T _A = 25°C, f = 1 MHz, V _{DD} = V _{DD} (typ)	8	pF
C _I	Input pin capacitance		6	pF

Note

3. This parameter is characterized and not 100% tested.

Thermal resistance

11 Thermal resistance

Table 14 Thermal resistance

Parameter	Description	Test conditions	8-pin PDIP	Unit
θ_{JA}	Thermal resistance (junction to ambient)	Test conditions follow standard test methods and procedures for measuring thermal impedance, per EIA / JESD51.	56	°C/W
θ_{JC}	Thermal resistance (junction to case)		43	°C/W

AC test conditions

12 AC test conditions

Table 15 AC test conditions

Parameter	Value
Input pulse levels	10% and 90% of V_{DD}
Input rise and fall times	3 ns
Input and output timing reference levels	$0.5 \times V_{DD}$
Output load capacitance	30 pF

13 AC switching characteristics

Table 16 AC switching characteristics

Over the **Operating range**

Parameters ^[4]		Description	V _{DD} = 2.0 V to 3.6 V		Unit
Parameter	Alt. parameter		Min	Max	
f _{SCK}	–	SCK clock frequency	0	25	MHz
t _{CH}	–	Clock HIGH time	18	–	ns
t _{CL}	–	Clock LOW time	18	–	ns
t _{CSU}	t _{CSS}	Chip select setup	12	–	ns
t _{CSH}	t _{CSH}	Chip select hold	12	–	ns
t _{OD} ^[5, 6]	t _{HZCS}	Output disable time	–	20	ns
t _{ODV}	t _{CO}	Output data valid time	–	16	ns
t _{OH}	–	Output hold time	0	–	ns
t _D	–	Deselect time	60	–	ns
t _{SU}	t _{SD}	Data setup time	8	–	ns
t _H	t _{HD}	Data hold time	8	–	ns

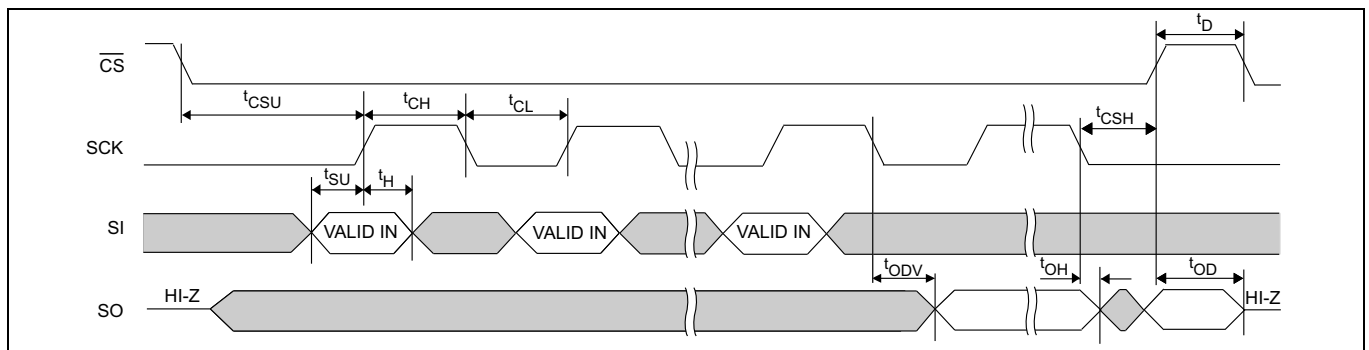

Figure 15 Synchronous data timing (Mode 0)

Notes

- Test conditions assume a signal transition time of 3 ns or less, timing reference levels of 0.5 × V_{DD}, input pulse levels of 10% to 90% of V_{DD}, and output loading of the specified I_{OL}/I_{OH} and 30 pF load capacitance shown in **AC test conditions**.

14 Power cycle timing

Table 17 Power cycle timing

Over the **Operating range**

Parameter	Description	Min	Max	Unit
t_{PU}	Power-up $V_{DD}(\min)$ to first access (\overline{CS} LOW)	1	–	ms
t_{PD}	Last access (\overline{CS} HIGH) to power-down ($V_{DD}(\min)$)	0	–	μs
$t_{VR}^{[7]}$	V_{DD} power-up ramp rate	50	–	$\mu\text{s}/\text{V}$
$t_{VF}^{[7]}$	V_{DD} power-down ramp rate	100	–	$\mu\text{s}/\text{V}$
$t_{REC}^{[8]}$	Recovery time from sleep mode	–	450	μs

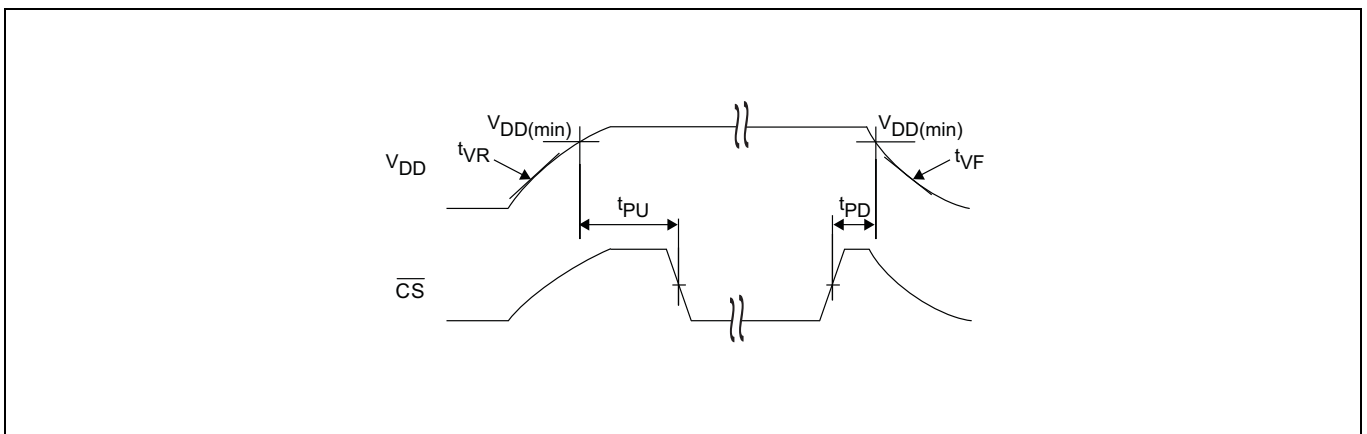

Figure 16 Power cycle timing

Notes

- Slope measured at any point on the V_{DD} waveform.
- Guaranteed by design. Refer to **Figure 13** for sleep mode recovery timing.

Ordering information

15 Ordering information

Table 18 Ordering information

Product	Package diagram	Package type	Operating range
FM25V20A (PDIP)-PG	51-85075	8-pin PDIP	Industrial

All these parts are Pb-free. Contact your local Infineon sales representative for availability of these parts.

15.1 Ordering code definitions

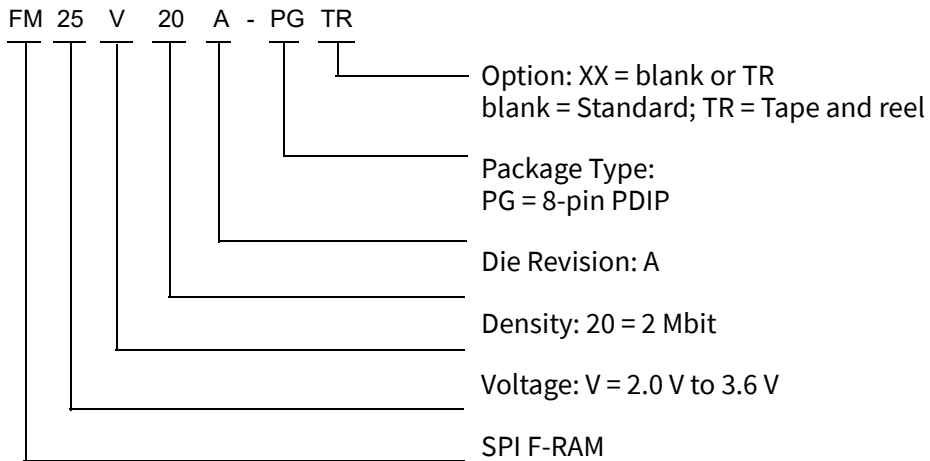

Package diagram

16 Package diagram

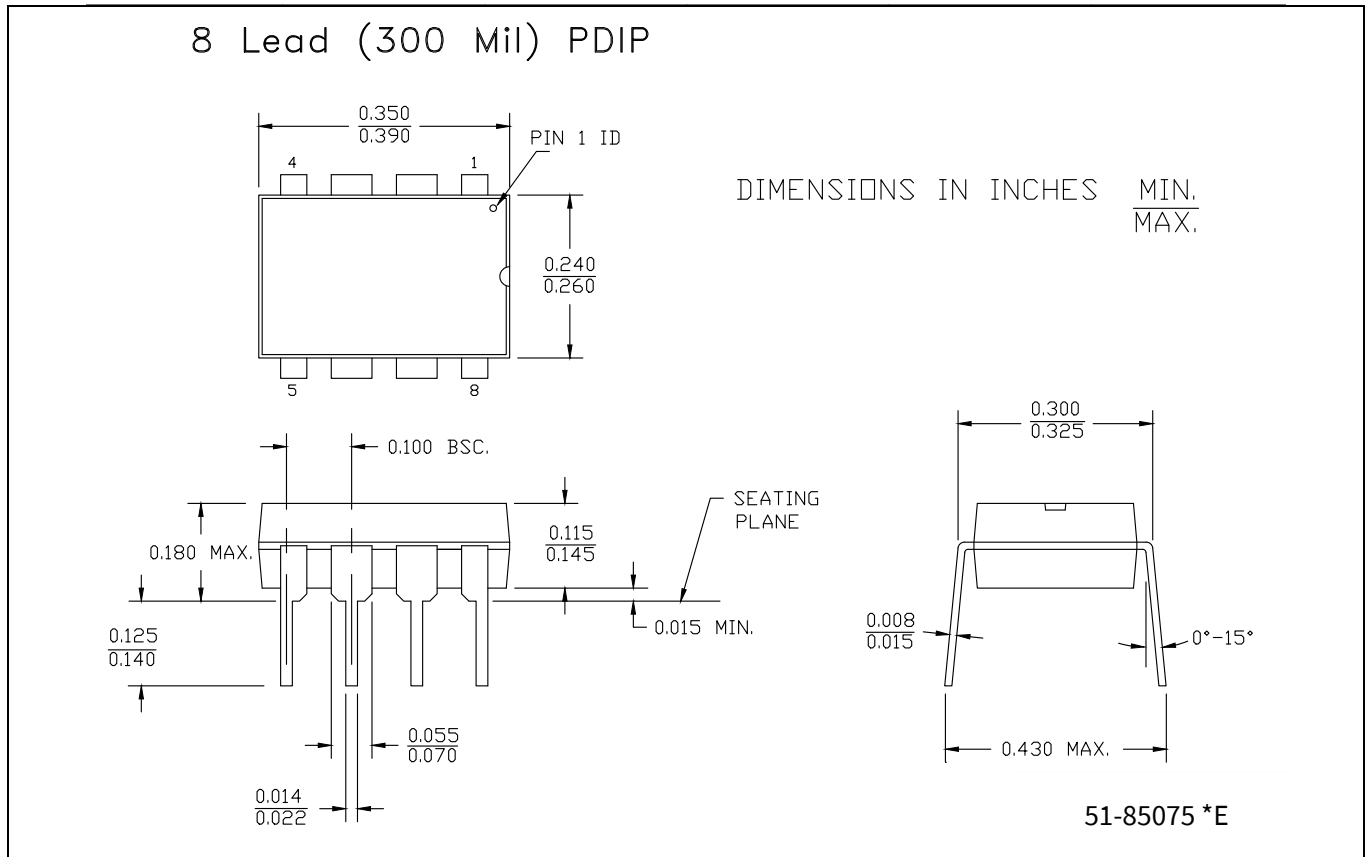

Figure 17 8-pin PDIP (300 Mils) package outline (PG-DIP-8), 51-85075

17 Acronyms

Table 19 Acronyms used in this document

Acronym	Description
CPHA	clock phase
CPOL	clock polarity
EEPROM	electrically erasable programmable read-only memory
EIA	electronic industries alliance
F-RAM	ferroelectric random access memory
I/O	input/output
JEDEC	Joint Electron Devices Engineering Council
JESD	JEDEC standards
LSB	least significant bit
MSB	most significant bit
PDIP	plastic dual in-line package
RoHS	restriction of hazardous substances
SPI	serial peripheral interface

18 Document conventions

18.1 Units of measure

Table 20 Units of measure

Symbol	Unit of measure
°C	degree Celsius
Hz	hertz
kHz	kilohertz
kΩ	kilohm
Mbit	megabit
MHz	megahertz
μA	microampere
μF	microfarad
μs	microsecond
mA	milliampere
ms	millisecond
ns	nanosecond
Ω	ohm
%	percent
pF	picofarad
V	volt
W	watt

Revision history

Document revision	Date	Description of changes
**	2014/01/22	New datasheet.
*A	2014/06/02	Changed status from Preliminary to Final. Updated Maximum Ratings: Changed “Human Body Model” from 2 kV to 4 kV under Electrostatic Discharge Voltage. Changed “Charged Device Model” from 500 V to 1.25 kV under Electrostatic Discharge Voltage. Removed “Machine Model” under Electrostatic Discharge Voltage. Updated Ordering Information: Removed FM25V20A-PGES part number.
*B	2015/08/10	Updated Maximum Ratings: Removed “Maximum junction temperature”. Added “Maximum accumulated storage time”. Added “Ambient temperature with power applied”. Updated Package Diagrams: spec 51-85075 – Changed revision from *C to *D. Updated to new template.
*C	2019/05/15	Removed HOLD pin function related information: Logic Block Diagram: Removed HOLD pin. Pinout (Figure 1): Updated Pin 7 from HOLD to DNU. Pin Definitions: Removed HOLD related information from SO pin definition. Removed HOLD pin definition and added DNU pin definition. Figure 2 and Figure 3: Removed HOLD pin connection. Data Transmission (SI/SO): Removed HOLD pin related operation. Page 9: Removed HOLD Pin Operation. AC Switching Characteristics: Removed HOLD pin timings. Removed HOLD pin timing (Figure 16). Updated Copyright information.
*D	2019/08/28	Updated Features. DC Electrical Characteristics: Updated IDD@1MHz (Max.) value from 0.30 mA to 0.8 mA. Updated IDD@25MHz (Typ.) value from 1.3 mA to 1.5 mA. AC Switching Characteristics: Removed tR and tF specs. Removed footnote 7 referenced to tR and tF specs.
*E	2023-02-09	Migrated to the Infineon template. Updated Figure 17 . Updated Table 1 .

Trademarks

All referenced product or service names and trademarks are the property of their respective owners.

Edition 2024-02-09

Published by

**Infineon Technologies AG
81726 Munich, Germany**

**© 2024 Infineon Technologies AG.
All Rights Reserved.**

Do you have a question about this document?

Email:

erratum@infineon.com

Document reference

001-90311 Rev. *E

IMPORTANT NOTICE

The information given in this document shall in no event be regarded as a guarantee of conditions or characteristics ("Beschaffenheitsgarantie").

With respect to any examples, hints or any typical values stated herein and/or any information regarding the application of the product, Infineon Technologies hereby disclaims any and all warranties and liabilities of any kind, including without limitation warranties of non-infringement of intellectual property rights of any third party.

In addition, any information given in this document is subject to customer's compliance with its obligations stated in this document and any applicable legal requirements, norms and standards concerning customer's products and any use of the product of Infineon Technologies in customer's applications.

The data contained in this document is exclusively intended for technically trained staff. It is the responsibility of customer's technical departments to evaluate the suitability of the product for the intended application and the completeness of the product information given in this document with respect to such application.

WARNINGS

Due to technical requirements products may contain dangerous substances. For information on the types in question please contact your nearest Infineon Technologies office.

Except as otherwise explicitly approved by Infineon Technologies in a written document signed by authorized representatives of Infineon Technologies, Infineon Technologies' products may not be used in any applications where a failure of the product or any consequences of the use thereof can reasonably be expected to result in personal injury.