

Description

The 9FGV0231 is a 2-output very low-power clock generator for PCIe Gen 1, 2, 3 and 4 Common Clocked (CC) applications. The device has 2 output enables for clock management and supports 2 different spread spectrum levels in addition to spread off.

Recommended Application

PCIe Gen1-4 clock generation for Riser Cards, Storage, Networking, JBOD, Communications, Access Points

Output Features

- 2 - 0.7V low-power HCSL-compatible (LP-HCSL) DIF pairs
- 1 - 1.8V LVCMOS REF output w/Wake-On-LAN (WOL) support

Key Specifications

- DIF cycle-to-cycle jitter <50ps
- DIF output-to-output skew <50ps
- PCIe Gen1-2-3-4 CC-compliant
- REF phase jitter is < 1.5ps RMS

Features/Benefits

- 1.8V operation; reduced power consumption
- OE# pins; support DIF power management
- LP-HCSL differential clock outputs; reduced power and board space
- Programmable Slew rate for each output; allows tuning for various line lengths
- Programmable output amplitude; allows tuning for various application environments
- DIF outputs blocked until PLL is locked; clean system start-up
- Selectable 0%, -0.25% or -0.5% spread on DIF outputs; reduces EMI
- External 25MHz crystal; supports tight ppm with 0 ppm synthesis error
- Configuration can be accomplished with strapping pins; SMBus interface not required for device control
- 3.3V tolerant SMBus interface works with legacy controllers
- Space saving 4 x 4 mm 24-VFQFPN; minimal board space

Block Diagram

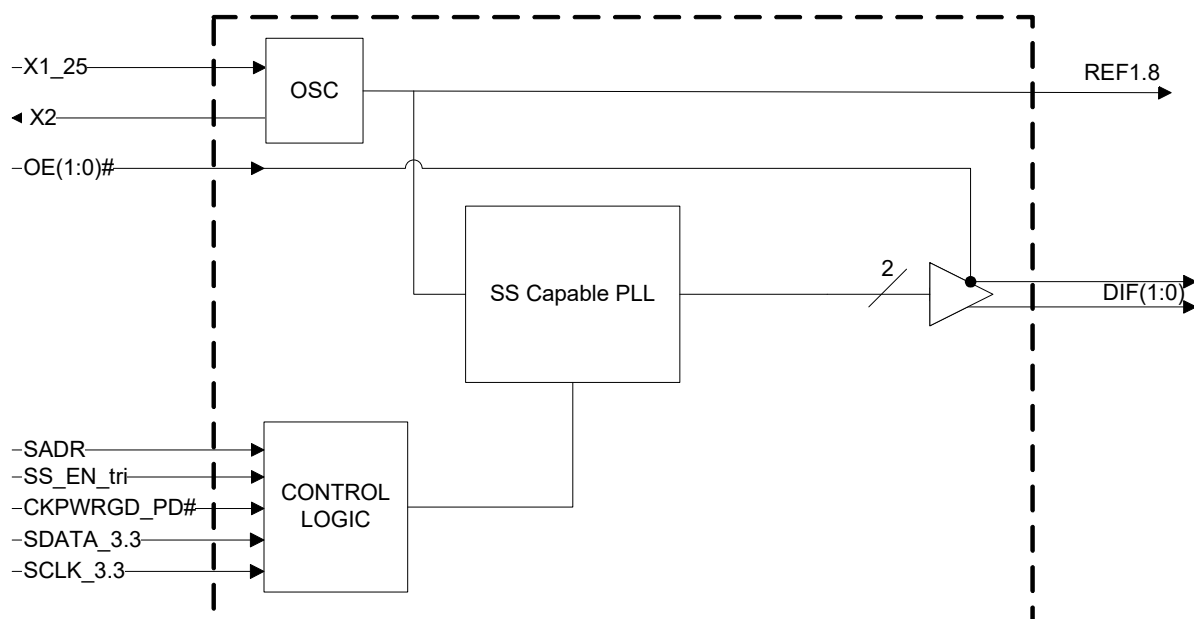

Pin Configuration

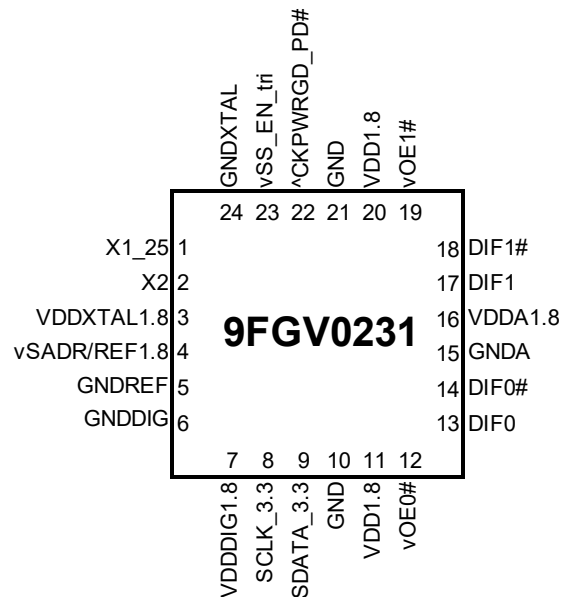

24-pin VFQFPN, 4x4 mm, 0.5mm pitch

^ prefix indicates internal 120KOhm pull up resistor
v prefix indicates internal 120KOhm pull down resistor

SMBus Address Selection Table

	SADR	Address	+ Read/Write Bit
State of SADR on first application of CKPWRGD_PD#	0	1101000	x
	1	1101010	x

Power Management Table

CKPWRGD_PD#	SMBus OE bit	DIFx		REF
		True O/P	Comp. O/P	
0	X	Low	Low	Hi-Z ¹
1	1	Running	Running	Running
1	0	Low	Low	Low

1. REF is Hi-Z until the 1st assertion of CKPWRGD_PD# high. After this, when CKPWRGD_PD# is low, REF is Low.

Power Connections

Pin Number		Description
VDD	GND	
3	5,24	XTAL, REF
7	6	Digital
11,20	10,21	DIF outputs
16	15	PLL Analog

Pin Descriptions

Pin#	Pin Name	Type	Pin Description
1	X1_25	IN	Crystal input, Nominally 25.00MHz.
2	X2	OUT	Crystal output.
3	VDDXTAL1.8	PWR	Power supply for XTAL, nominal 1.8V
4	vSADR/REF1.8	LATCHED I/O	Latch to select SMBus Address/1.8V LVCMOS copy of X1 pin.
5	GNDREF	GND	Ground pin for the REF outputs.
6	GNDDIG	GND	Ground pin for digital circuitry
7	VDDDIG1.8	PWR	1.8V digital power (dirty power)
8	SCLK_3.3	IN	Clock pin of SMBus circuitry, 3.3V tolerant.
9	SDATA_3.3	I/O	Data pin for SMBus circuitry, 3.3V tolerant.
10	GND	GND	Ground pin.
11	VDD1.8	PWR	Power supply, nominal 1.8V
12	vOE0#	IN	Active low input for enabling DIF pair 0. This pin has an internal pull-down. 1 =disable outputs, 0 = enable outputs
13	DIF0	OUT	Differential true clock output
14	DIF0#	OUT	Differential Complementary clock output
15	GND	GND	Ground pin for the PLL core.
16	VDDA1.8	PWR	1.8V power for the PLL core.
17	DIF1	OUT	Differential true clock output
18	DIF1#	OUT	Differential Complementary clock output
19	vOE1#	IN	Active low input for enabling DIF pair 1. This pin has an internal pull-down. 1 =disable outputs, 0 = enable outputs
20	VDD1.8	PWR	Power supply, nominal 1.8V
21	GND	GND	Ground pin.
22	^CKPWRGD_PD#	IN	Input notifies device to sample latched inputs and start up on first high assertion. Low enters Power Down Mode, subsequent high assertions exit Power Down Mode. This pin has internal pull-up resistor.
23	vSS_EN_tri	LATCHED IN	Latched select input to select spread spectrum amount at initial power up : 1 = -0.5% spread, M = -0.25%, 0 = Spread Off
24	GNDXTAL	GND	GND for XTAL

Test Loads

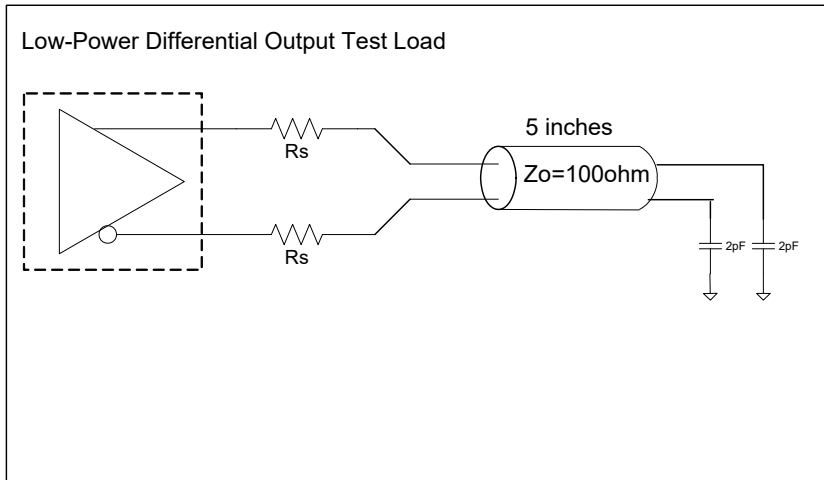

Alternate Differential Output Terminations

Rs	Zo	Units
33	100	Ohms
27	85	

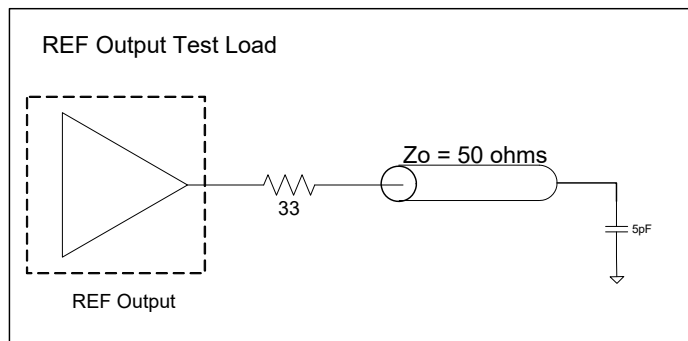

Alternate Terminations

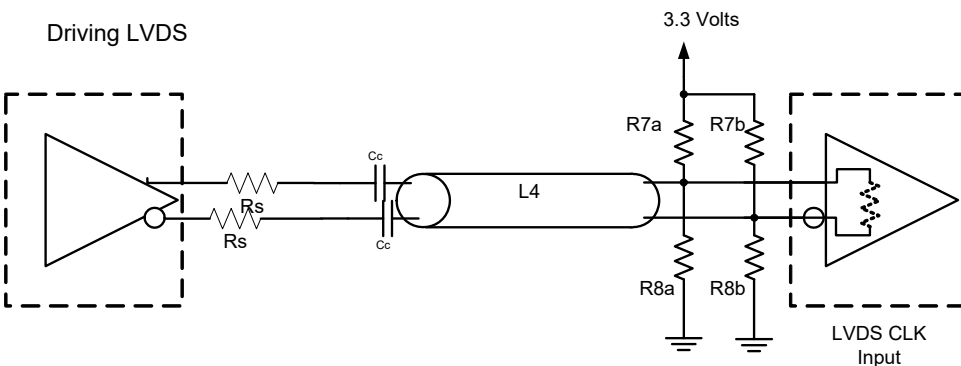

Driving LVDS inputs with the 9FGV0231

Component	Value		Note
	Receiver has termination	Receiver does not have termination	
R7a, R7b	10K ohm	140 ohm	
R8a, R8b	5.6K ohm	75 ohm	
Cc	0.1 uF	0.1 uF	
Vcm	1.2 volts	1.2 volts	

Absolute Maximum Ratings

Stresses above the ratings listed below can cause permanent damage to the 9FGV0231. These ratings, which are standard values for IDT commercially rated parts, are stress ratings only. Functional operation of the device at these or any other conditions above those indicated in the operational sections of the specifications is not implied. Exposure to absolute maximum rating conditions for extended periods can affect product reliability. Electrical parameters are guaranteed only over the recommended operating temperature range.

PARAMETER	SYMBOL	CONDITIONS	MIN	TYP	MAX	UNITS	NOTES
1.8V Supply Voltage	VDDxx	Applies to All VDD pins	-0.5		2.5	V	1,2
Input Voltage	V _{IN}		-0.5		V _{DD} +0.3V	V	1, 3
Input High Voltage, SMBus	V _{IHSMB}	SMBus clock and data pins			3.6V	V	1
Storage Temperature	T _s		-65		150	°C	1
Junction Temperature	T _j				125	°C	1
Input ESD protection	ESD prot	Human Body Model	2000			V	1

¹Guaranteed by design and characterization, not 100% tested in production.

²Operation under these conditions is neither implied nor guaranteed.

³Not to exceed 2.5V.

Electrical Characteristics–Current Consumption

TA = T_{COM} or T_{IND}, Supply Voltage per VDD of normal operation conditions, See Test Loads for Loading Conditions

PARAMETER	SYMBOL	CONDITIONS	MIN	TYP	MAX	UNITS	NOTES
Operating Supply Current	I _{DDAOP}	VDDA, PLL Mode, All outputs active @100MHz		7	8	mA	1
	I _{DDOP}	VDD, All outputs active @100MHz		15	18	mA	1
Suspend Supply Current	I _{DDSUSP}	VDDxxx, PD# = 0, Wake-On-LAN enabled		6	8	mA	1
Powerdown Current	I _{DDPD}	PD#=0		0.6	1	mA	1, 2

¹Guaranteed by design and characterization, not 100% tested in production.

²Assuming REF is not running in power down state

Electrical Characteristics – Output Duty Cycle, Jitter, and Skew Characteristics

TA = T_{COM} or T_{IND}, Supply Voltage per VDD of normal operation conditions, See Test Loads for Loading Conditions

PARAMETER	SYMBOL	CONDITIONS	MIN	TYP	MAX	UNITS	NOTES
Duty Cycle	t _{DC}	Measured differentially, PLL Mode	45	49.9	55	%	1
Skew, Output to Output	t _{sk3}	V _T = 50%		37	50	ps	1
Jitter, Cycle to cycle	t _{jcy-cyc}	PLL mode		12	50	ps	1,2

¹Guaranteed by design and characterization, not 100% tested in production.

²Measured from differential waveform

Electrical Characteristics–Input/Supply/Common Parameters–Normal Operating Conditions

TA = T_{COM} or T_{IND}; Supply Voltage per VDD of normal operation conditions, See Test Loads for Loading Conditions

PARAMETER	SYMBOL	CONDITIONS	MIN	TYP	MAX	UNITS	NOTES
1.8V Supply Voltage	VDD	Supply voltage for core, analog and single-ended LVCMOS outputs	1.7	1.8	1.9	V	1
Ambient Operating Temperature	T _{COM}	Commercial range	0	25	70	°C	1
	T _{IND}	Industrial range	-40	25	85	°C	1
Input High Voltage	V _{IH}	Single-ended inputs, except SMBus	0.75 V _{DD}		V _{DD} + 0.3	V	1
Input Mid Voltage	V _{IM}	Single-ended tri-level inputs ('_tri' suffix, if present)	0.4 V _{DD}		0.6 V _{DD}	V	1
Input Low Voltage	V _{IL}	Single-ended inputs, except SMBus	-0.3		0.25 V _{DD}	V	1
Schmitt Trigger Positive Going Threshold Voltage	V _{T+}	Single-ended inputs, where indicated	0.4 V _{DD}		0.7 V _{DD}	V	1
Schmitt Trigger Negative Going Threshold Voltage	V _{T-}	Single-ended inputs, where indicated	0.1 V _{DD}		0.4 V _{DD}	V	1
Hysteresis Voltage	V _H	V _{T+} - V _{T-}	0.1 V _{DD}		0.4 V _{DD}	V	1
Output High Voltage	V _{IH}	Single-ended outputs, except SMBus. I _{OH} = -2mA	V _{DD} -0.45			V	1
Output Low Voltage	V _{IL}	Single-ended outputs, except SMBus. I _{OL} = -2mA			0.45	V	1
Input Current	I _{IN}	Single-ended inputs, V _{IN} = GND, V _{IN} = VDD	-5		5	uA	1
	I _{INP}	Single-ended inputs V _{IN} = 0 V; Inputs with internal pull-up resistors V _{IN} = VDD; Inputs with internal pull-down resistors	-20		20	uA	1
Input Frequency	F _{in}	XTAL, or X1 input	23	25	27	MHz	1
Pin Inductance	L _{pin}				7	nH	1
Capacitance	C _{IN}	Logic Inputs, except DIF_IN	1.5		5	pF	1
	C _{OUT}	Output pin capacitance			6	pF	1
Clk Stabilization	T _{STAB}	From V _{DD} Power-Up and after input clock stabilization or de-assertion of PD# to 1st clock		0.6	1.8	ms	1,2
SS Modulation Frequency	f _{MOD}	Allowable Frequency (Triangular Modulation)	31	31.6	32	kHz	1
OE# Latency	t _{LATOE#}	DIF start after OE# assertion DIF stop after OE# deassertion	1	2	3	clocks	1,3
Tdrive_PD#	t _{DRVPD}	DIF output enable after PD# de-assertion			300	us	1,3
Tfall	t _F	Fall time of single-ended control inputs			5	ns	1,2
Trise	t _R	Rise time of single-ended control inputs			5	ns	1,2
SMBus Input Low Voltage	V _{ILSMB}	V _{DD} SMB = 3.3V, see note 4 for V _{DD} SMB < 3.3V			0.8	V	1,4
SMBus Input High Voltage	V _{IHSMB}	V _{DD} SMB = 3.3V, see note 5 for V _{DD} SMB < 3.3V	2.1		3.6	V	1,5
SMBus Output Low Voltage	V _{OLSMB}	@ I _{PULLUP}			0.4	V	1
SMBus Sink Current	I _{PULLUP}	@ V _{OL}	4			mA	1
Nominal Bus Voltage	V _{DD} SMB		1.7		3.6	V	1
SCLK/SDATA Rise Time	t _{RSMB}	(Max V _{IL} - 0.15) to (Min V _{IH} + 0.15)			1000	ns	1
SCLK/SDATA Fall Time	t _{FSMB}	(Min V _{IH} + 0.15) to (Max V _{IL} - 0.15)			300	ns	1
SMBus Operating Frequency	f _{MAXSMB}	Maximum SMBus operating frequency			400	kHz	1

¹ Guaranteed by design and characterization, not 100% tested in production.

² Control input must be monotonic from 20% to 80% of input swing.

³ Time from deassertion until outputs are > 200mV.

⁴ For V_{DD}SMB < 3.3V, V_{ILSMB} <= 0.35V_{DD}SMB.

⁵ For V_{DD}SMB < 3.3V, V_{IHSMB} >= 0.65V_{DD}SMB.

Electrical Characteristics–DIF 0.7V Low Power HCSL Outputs

TA = T_{COM} or T_{IND}; Supply Voltage per VDD of normal operation conditions, See Test Loads for Loading Conditions

PARAMETER	SYMBOL	CONDITIONS	MIN	TYP	MAX	UNITS	NOTES
Slew rate	Trf	Scope averaging on 3.0V/ns setting	2	3	4	V/ns	1, 2, 3
		Scope averaging on 2.0V/ns setting	1	2	3	V/ns	1, 2, 3
Slew rate matching	ΔTrf	Slew rate matching, Scope averaging on		5	20	%	1,2,4
Voltage High	V _{HIGH}	Statistical measurement on single-ended signal using oscilloscope math function. (Scope averaging on)	660	793	850	mV	1,8
Voltage Low	V _{LOW}		-150	16	150		1
Max Voltage	V _{max}	Measurement on single ended signal using absolute value. (Scope averaging off)		831	1150	mV	1
Min Voltage	V _{min}		-300	-95			1
Vswing	V _{swing}	Scope averaging off	300	1555		mV	1,2
Crossing Voltage (abs)	V _{cross_abs}	Scope averaging off	300	429	550	mV	1,5
Crossing Voltage (var)	Δ-V _{cross}	Scope averaging off		60	140	mV	1,6

¹Guaranteed by design and characterization, not 100% tested in production. C_L = 2pF with R_S = 33Ω for Zo = 50Ω (100Ω differential trace impedance).

² Measured from differential waveform

³ Slew rate is measured through the V_{swing} voltage range centered around differential 0V. This results in a +/-150mV window around differential 0V.

⁴ Matching applies to rising edge rate for Clock and falling edge rate for Clock#. It is measured using a +/-75mV window centered on the average cross point where Clock rising meets Clock# falling. The median cross point is used to calculate the voltage thresholds the oscilloscope is to use for the edge rate calculations.

⁵ V_{cross} is defined as voltage where Clock = Clock# measured on a component test board and only applies to the differential rising edge (i.e. Clock rising and Clock# falling).

⁶ The total variation of all V_{cross} measurements in any particular system. Note that this is a subset of V_{cross_min/max} (V_{cross} absolute) allowed. The intent is to limit V_{cross} induced modulation by setting Δ-V_{cross} to be smaller than V_{cross} absolute.

⁷ At default SMBus settings.

Electrical Characteristics–Filtered Phase Jitter Parameters - PCIe Common Clocked (CC) Architectures

T_{AMB} = over the specified operating range. Supply Voltages per normal operation conditions, See Test Loads for Loading Conditions

SYMBOL	PARAMETER	CONDITIONS	MIN	TYP	MAX	Specification Limit	UNITS	NOTES
t _{jphPCIEG1-CC}	Phase Jitter, PLL Mode	PCIe Gen 1	21	25	35	86	ps (p-p)	1, 2, 3
t _{jphPCIEG2-CC}		PCIe Gen 2 Low Band 10kHz < f < 1.5MHz (PLL BW of 5-16MHz, 8-16MHz, CDR = 5MHz)	0.9	0.9	1.1	3	ps (rms)	1, 2
		PCIe Gen 2 High Band 1.5MHz < f < Nyquist (50MHz) (PLL BW of 5-16MHz, 8-16MHz, CDR = 5MHz)	1.5	1.6	1.9	3.1	ps (rms)	1, 2
t _{jphPCIEG3-CC}		PCIe Gen 3 (PLL BW of 2-4MHz, 2-5MHz, CDR = 10MHz)	0.3	0.37	0.44	1	ps (rms)	1, 2
t _{jphPCIEG4-CC}		PCIe Gen 4 (PLL BW of 2-4MHz, 2-5MHz, CDR = 10MHz)	0.3	0.37	0.44	0.5	ps (rms)	1, 2

Notes on PCIe Filtered Phase Jitter Tables

¹ Applies to all differential outputs, guaranteed by design and characterization.

² Calculated from Intel-supplied Clock Jitter Tool, with spread on and off.

³ Sample size of at least 100K cycles. This figure extrapolates to 108ps pk-pk at 1M cycles for a BER of 1⁻¹².

Electrical Characteristics–REF

TA = T_{COM} or T_{IND}; Supply Voltage per VDD of normal operation conditions, See Test Loads for Loading Conditions

PARAMETER	SYMBOL	CONDITIONS	MIN	TYP	MAX	UNITS	Notes
Long Accuracy	ppm	see T _{period} min-max values	0			ppm	1,2
Clock period	T _{period}	25 MHz output nominal		40		ns	1,2
Rise/Fall Slew Rate	t _{rf1}	V _{OH} = VDD-0.45V, V _{OL} = 0.45V	0.5	1.3	2.5	V/ns	1,3
Duty Cycle	d _{t1}	V _T = VDD/2 V	45	49.1	55	%	1,4
Duty Cycle Distortion	d _{tcd}	V _T = VDD/2 V	0	2	3	%	1,5
Jitter, cycle to cycle	t _{iccyc-cyc}	V _T = VDD/2 V		19	250	ps	1,4
Noise floor	t _{dBc1k}	1kHz offset		-130	-105	dBc	1,4
Noise floor	t _{dBc10k}	10kHz offset to Nyquist		-140	-120	dBc	1,4
Jitter, phase	t _{phREF}	12kHz to 5MHz		0.63	1.5	ps (rms)	1,4

¹Guaranteed by design and characterization, not 100% tested in production.

²All Long Term Accuracy and Clock Period specifications are guaranteed assuming that REF is trimmed to 25.00 MHz

³Typical value occurs when REF slew rate is set to default value

⁴When driven by a crystal.

⁵When driven by an external oscillator via the X1 pin. X2 should be floating in this case.

Clock Periods–Differential Outputs with Spread Spectrum Disabled

SSC OFF	Center Freq. MHz	Measurement Window							Units	Notes
		1 Clock	1us	0.1s	0.1s	0.1s	1us	1 Clock		
		-c2c jitter	-SSC Sh	- ppm L	0 ppm Period Nominal	+ ppm L	+SSC Sh	+c2c jitter		
DIF	100.00	9.94900		9.99900	10.00000	10.00100		10.05100	ns	1,2

Clock Periods–Differential Outputs with -0.5% Spread Spectrum Enabled

SSC ON	Center Freq. MHz	Measurement Window							Units	Notes	
		1 Clock	1us	0.1s	0.1s	0.1s	1us	1 Clock			
		-c2c jitter	-SSC Sh	- ppm L	0 ppm Period Nominal	+ ppm L	+SSC Sh	+c2c jitter			
DIF	99.75	9.94906	9.99906	10.02406	10.02506	10.02607		10.05107	10.10107	ns	1,2

¹Guaranteed by design and characterization, not 100% tested in production.

²All Long Term Accuracy and Clock Period specifications are guaranteed assuming that REF is trimmed to 25.00 MHz

General SMBus Serial Interface Information

How to Write

- Controller (host) sends a start bit
- Controller (host) sends the write address
- IDT clock will **acknowledge**
- Controller (host) sends the beginning byte location = N
- IDT clock will **acknowledge**
- Controller (host) sends the byte count = X
- IDT clock will **acknowledge**
- Controller (host) starts sending Byte N through Byte N+X-1
- IDT clock will **acknowledge** each byte **one at a time**
- Controller (host) sends a stop bit

Index Block Write Operation		
Controller (Host)		IDT (Slave/Receiver)
T	starT bit	
Slave Address		
WR	WRite	
Beginning Byte = N		ACK
		ACK
Data Byte Count = X		ACK
Beginning Byte N		ACK
O	X Byte	O
O		O
O		O
Byte N + X - 1		ACK
P	stoP bit	

Note: Read/Write address is determined by SADR latch.

How to Read

- Controller (host) will send a start bit
- Controller (host) sends the write address
- IDT clock will **acknowledge**
- Controller (host) sends the beginning byte location = N
- IDT clock will **acknowledge**
- Controller (host) will send a separate start bit
- Controller (host) sends the read address
- IDT clock will **acknowledge**
- IDT clock will send the data byte count = X
- IDT clock sends Byte N+X-1
- IDT clock sends **Byte 0 through Byte X (if X_(H) was written to Byte 8)**
- Controller (host) will need to acknowledge each byte
- Controller (host) will send a not acknowledge bit
- Controller (host) will send a stop bit

Index Block Read Operation		
Controller (Host)		IDT (Slave/Receiver)
T	starT bit	
Slave Address		
WR	WRite	
Beginning Byte = N		ACK
		ACK
RT	Repeat starT	
Slave Address		
RD	ReaD	
		ACK
ACK		Data Byte Count=X
		Beginning Byte N
ACK		O
O		O
O		O
O		
		Byte N + X - 1
N	Not acknowledge	
P	stoP bit	

SMBus Table: Output Enable Register

Byte 0	Name	Control Function	Type	0	1	Default
Bit 7		Reserved				1
Bit 6		Reserved				1
Bit 5		Reserved				1
Bit 4		Reserved				1
Bit 3		Reserved				1
Bit 2	DIF OE1	Output Enable	RW	Low/Low	Enabled	1
Bit 1	DIF OE0	Output Enable	RW	Low/Low	Enabled	1
Bit 0		Reserved				1

SMBus Table: SS Readback and Vhigh Control Register

Byte 1	Name	Control Function	Type	0	1	Default
Bit 7	SSENRB1	SS Enable Readback Bit1	R	00' for SS_EN_tri = 0, '01' for SS_EN_tri = 'M', '11 for SS_EN_tri = '1'		Latch
Bit 6	SSENRB1	SS Enable Readback Bit0	R			Latch
Bit 5	SSEN_SWCNTRL	Enable SW control of SS	RW	SS control locked	Values in B1[4:3] control SS amount.	0
Bit 4	SSENSW1	SS Enable Software Ctl Bit1	RW ¹	00' = SS Off, '01' = -0.25% SS,		0
Bit 3	SSENSW0	SS Enable Software Ctl Bit0	RW ¹	'10' = Reserved, '11' = -0.5% SS		0
Bit 2		Reserved				1
Bit 1	AMPLITUDE 1	Controls Output Amplitude	RW	00 = 0.6V	01 = 0.7V	1
Bit 0	AMPLITUDE 0		RW	10 = 0.8V	11 = 0.9V	0

1. B1[5] must be set to a 1 for these bits to have any effect on the part.

SMBus Table: DIF Slew Rate Control Register

Byte 2	Name	Control Function	Type	0	1	Default
Bit 7		Reserved				1
Bit 6		Reserved				1
Bit 5		Reserved				1
Bit 4		Reserved				1
Bit 3		Reserved				1
Bit 2	SLEWRATESEL DIF1	Adjust Slew Rate of DIF1	RW	2.0V/ns	3.0V/ns	1
Bit 1	SLEWRATESEL DIF0	Adjust Slew Rate of DIF0	RW	2.0V/ns	3.0V/ns	1
Bit 0		Reserved				1

SMBus Table: REF Control Register

Byte 3	Name	Control Function	Type	0	1	Default
Bit 7	REF	Slew Rate Control	RW	00 = 0.9V/ns	01 = 1.3V/ns	0
Bit 6			RW	10 = 1.6V/ns	11 = 1.8V/ns	1
Bit 5	REF Power Down Function	Wake-on-Lan Enable for REF	RW	REF does not run in Power Down	REF runs in Power Down	0
Bit 4	REF OE	REF Output Enable	RW	Low	Enabled	1
Bit 3		Reserved				1
Bit 2		Reserved				1
Bit 1		Reserved				1
Bit 0		Reserved				1

Byte 4 is reserved and reads back 'hFF'.

SMBus Table: Revision and Vendor ID Register

Byte 5	Name	Control Function	Type	0	1	Default
Bit 7	RID3	Revision ID	R	A rev = 0000		0
Bit 6	RID2		R			0
Bit 5	RID1		R			0
Bit 4	RID0		R			0
Bit 3	VID3	VENDOR ID	R	0001 = IDT		0
Bit 2	VID2		R			0
Bit 1	VID1		R			0
Bit 0	VID0		R			1

SMBus Table: Device Type/Device ID

Byte 6	Name	Control Function	Type	0	1	Default
Bit 7	Device Type1	Device Type	R	00 = FGV, 01 = DBV, 10 = DMV, 11= Reserved		0
Bit 6	Device Type0		R			0
Bit 5	Device ID5	Device ID	R	00010 binary or 02 hex		0
Bit 4	Device ID4		R			0
Bit 3	Device ID3		R			0
Bit 2	Device ID2		R			0
Bit 1	Device ID1		R			1
Bit 0	Device ID0		R			0

SMBus Table: Byte Count Register

Byte 7	Name	Control Function	Type	0	1	Default
Bit 7		Reserved				0
Bit 6		Reserved				0
Bit 5		Reserved				0
Bit 4	BC4	Byte Count Programming	RW	Writing to this register will configure how many bytes will be read back, default is = 8 bytes.		0
Bit 3	BC3		RW			1
Bit 2	BC2		RW			0
Bit 1	BC1		RW			0
Bit 0	BC0		RW			0

Recommended Crystal Characteristics (3225 package)

PARAMETER	VALUE	UNITS	NOTES
Frequency	25	MHz	1
Resonance Mode	Fundamental	-	1
Frequency Tolerance @ 25°C	±20	PPM Max	1
Frequency Stability, ref @ 25°C Over Operating Temperature Range	±20	PPM Max	1
Temperature Range (commercial)	0~70	°C	1
Temperature Range (industrial)	-40~85	°C	2
Equivalent Series Resistance (ESR)	50	Ω Max	1
Shunt Capacitance (C ₀)	7	pF Max	1
Load Capacitance (C _L)	8	pF Max	1
Drive Level	0.3	mW Max	1
Aging per year	±5	PPM Max	1

Notes:

1. FOX 603-25-150.
2. For I-temp, FOX 603-25-261.

Thermal Characteristics

PARAMETER	SYMBOL	CONDITIONS	PKG	TYP VALUE	UNITS	NOTES
Thermal Resistance	θ_{JC}	Junction to Case	NLG20 NLG24	62	°C/W	1
	θ_{Jb}	Junction to Base		5.4	°C/W	1
	θ_{JA0}	Junction to Air, still air		50	°C/W	1
	θ_{JA1}	Junction to Air, 1 m/s air flow		43	°C/W	1
	θ_{JA3}	Junction to Air, 3 m/s air flow		39	°C/W	1
	θ_{JA5}	Junction to Air, 5 m/s air flow		38	°C/W	1

¹ePad soldered to board

Marking Diagrams

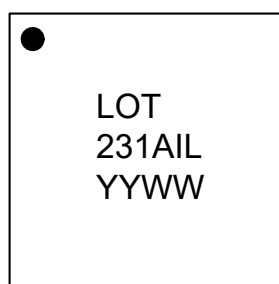
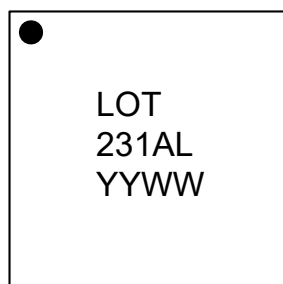

Notes:

1. 'LOT' is the lot number.
2. 'YYWW' is the last two digits of the year and week that the part was assembled.
3. 'L' denotes RoHS compliant package.
4. 'I' denotes industrial temperature grade.

Package Outline and Dimensions (NLG24)

DATE CREATED	REV	REVISIONS	AUTHOR
11/17/15	00	INITIAL RELEASE	JJH
9/9/16	01	ADD CHAMFER ON EPAD REFER TO DCP FOR OFFICIAL RELEASE DATE	JJH

SYMBOL

DIMENSIONS			
	MIN.	NOM.	MAX.
A	0.80	0.90	1.00
A1	0.00	0.02	0.05
A3	0.20 REF		
K	0.375		
D	4.00 BSC		
E	4.00 BSC		
D2	2.30	2.45	2.60
E2	2.30	2.45	2.60
e	0.50 BSC		
L	0.30	0.40	0.50
b	0.18	0.25	0.30

NOTES :

1. DIMENSIONING AND TOLERANCING CONFORME TO ASME Y14.5M - 1994.
2. ALL DIMENSIONS ARE IN MILLIMETERS.

TOLERANCES UNLESS SPECIFIED

DECIMAL	±
XXX.	
XXXX.	

www.IDT.com

6024 Silver Creek Valley Road
San Jose, CA 95138
PHONE: (408) 284-8200
FAX: (408) 284-6591

IDT

NL/NLG24P1 PACKAGE OUTLINE
4.0 x 4.0 mm BODY
0.5 mm PITCH QFN

SIZE: C
DRAWING No: PSC-4192-01
REV: O1

DO NOT SCALE DRAWING SHEET 1 OF 2

Package Outline and Dimensions (NLG24), cont.

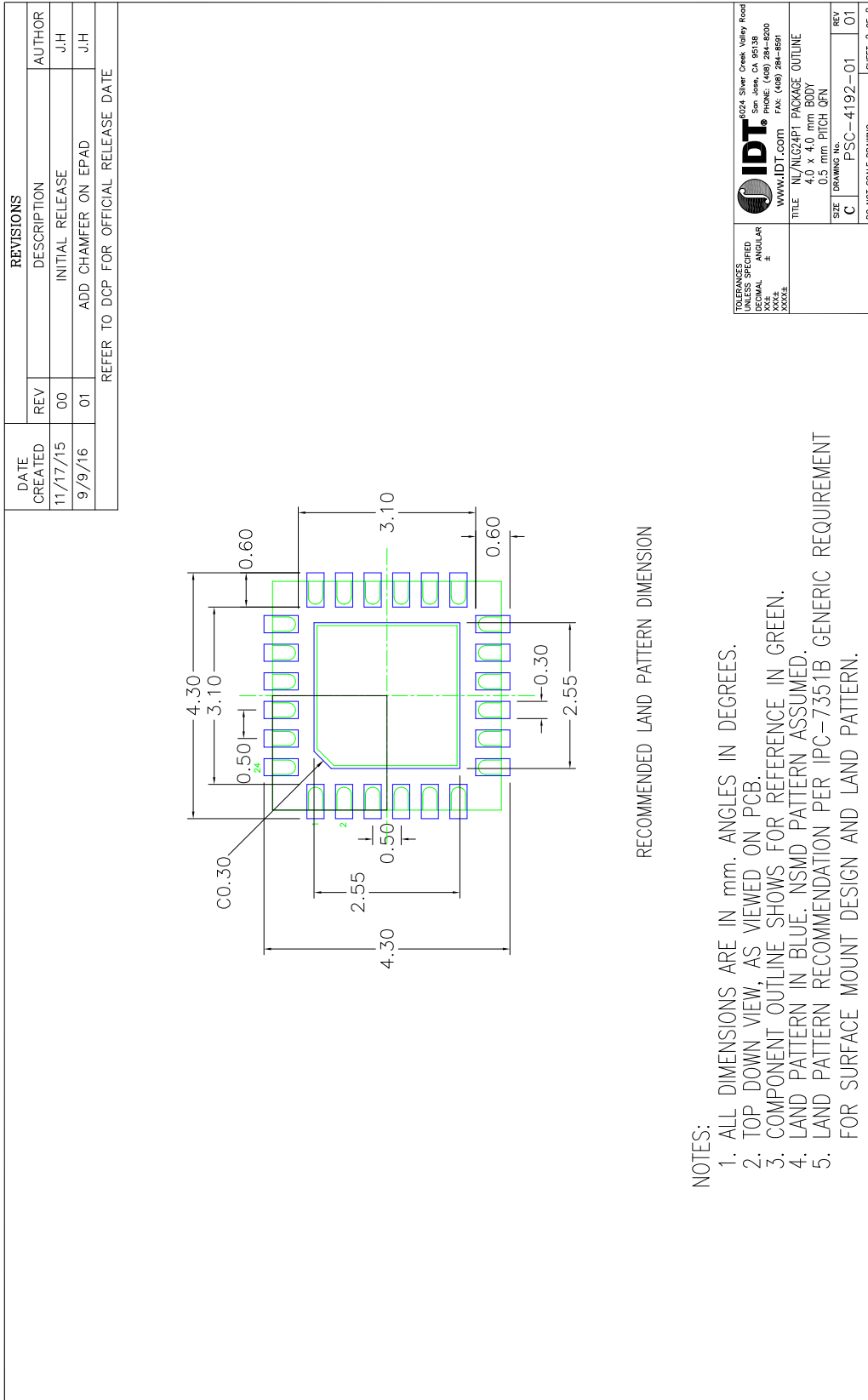

Ordering Information

Part / Order Number	Shipping Packaging	Package	Temperature
9FGV0231AKLF	Trays	24-pin VFQFPN	0 to +70° C
9FGV0231AKLFT	Tape and Reel	24-pin VFQFPN	0 to +70° C
9FGV0231AKILF	Trays	24-pin VFQFPN	-40 to +85° C
9FGV0231AKILFT	Tape and Reel	24-pin VFQFPN	-40 to +85° C

“LF” suffix to the part number are the Pb-Free configuration and are RoHS compliant.

“A” is the device revision designator (will not correlate with the datasheet revision).

Revision History

Issue Date	Description
February 3, 2015	Updated IDDAOP and IDDOP min and max specs per latest characterization review.
October 18, 2016	Removed IDT crystal part number
June 19, 2017	Updated front page Gendes to reflect the PCIe Gen4 updates.(Refer to yellow Highlights) Updated Electrical Characteristics - Filtered Phase Jitter Parameters - PCIe Common Clocked (CC) Architectures and added PCIe Gen4 Data
June 6, 2019	Updated Input Current minimum and maximum values from -200/200uA to -20/20uA.

Innovate with IDT and accelerate your future networks. Contact:

www.IDT.com

For Sales

800-345-7015

408-284-8200

www.idt.com/go/sales

For Tech Support

www.idt.com/go/support

Corporate Headquarters

Integrated Device Technology, Inc.

www.idt.com

DISCLAIMER Integrated Device Technology, Inc. (IDT) and its affiliated companies (herein referred to as "IDT") reserve the right to modify the products and/or specifications described herein at any time, without notice, at IDT's sole discretion. Performance specifications and operating parameters of the described products are determined in an independent state and are not guaranteed to perform the same way when installed in customer products. The information contained herein is provided without representation or warranty of any kind, whether express or implied, including, but not limited to, the suitability of IDT's products for any particular purpose, an implied warranty of merchantability, or non-infringement of the intellectual property rights of others. This document is presented only as a guide and does not convey any license under intellectual property rights of IDT or any third parties.

IDT's products are not intended for use in applications involving extreme environmental conditions or in life support systems or similar devices where the failure or malfunction of an IDT product can be reasonably expected to significantly affect the health or safety of users. Anyone using an IDT product in such a manner does so at their own risk, absent an express, written agreement by IDT.

Integrated Device Technology, IDT and the IDT logo are trademarks or registered trademarks of IDT and its subsidiaries in the United States and other countries. Other trademarks used herein are the property of IDT or their respective third party owners. For datasheet type definitions and a glossary of common terms, visit www.idt.com/go/glossary. Integrated Device Technology, Inc. All rights reserved.

