

Jul.1.2024 Copyright 2024 HIROSE ELECTRIC CO., LTD. All Rights Reserved.  
 In case of consideration for using Automotive equipment / device which demand high reliability, kindly contact our sales window correspondents.

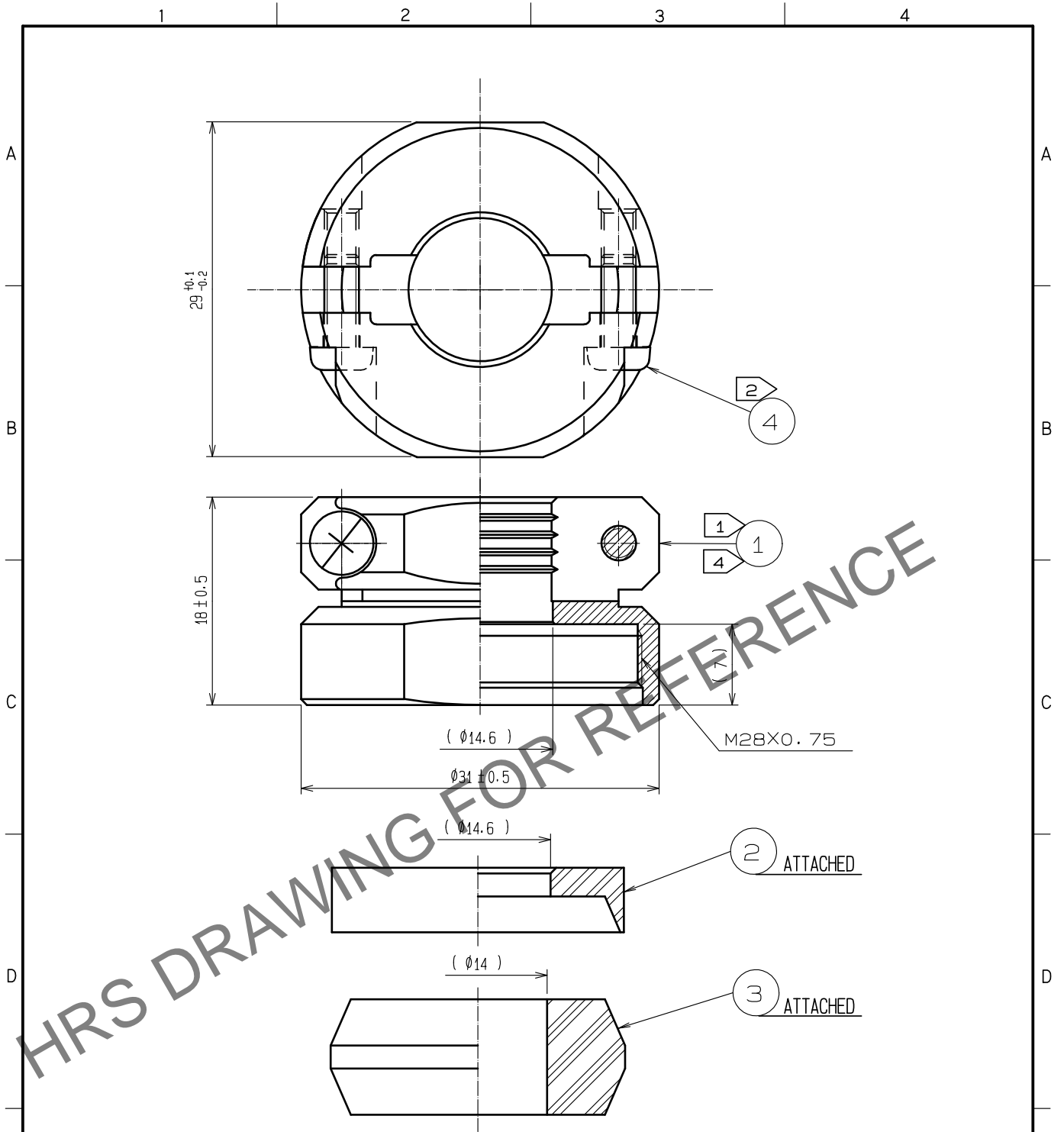

- NOTES
- ① THE RECOMMENDED CLAMP TORQUE OF REF.NO. ① TO BE 5 TO 5.5 N · m.  
LOCTITE 263, HENKEL JAPAN OR EQUIVALENT IS RECOMMENDED TO PREVENT REF.NO. ① FROM LOOSENING.
  - ② THE RECOMMENDED CLAMP TORQUE OF REF.NO. ② TO BE 0.65 TO 0.7 N · m.
  - ③ THE CABLE PULL AND TWISTING STRENGTH AND OTHER CHARACTERISTICS MAY DIFFER, DEPENDING ON THE CABLE STRUCTURE. PLEASE CONFIRM BEFORE THE USE.
  - ④ PORE SHOWN ON THE SURFACE OF REF NO. ① COMPONENT, GENERATED BY THE PROCESS OF MACHINING AFTER DIE-CASTING, WILL NOT AFFECT PERFORMANCE.

2	POLYPHENYLENE SULFIDE	(BLACK) UL94V-0	4	STAINLESS STEEL	M3X0.5X8		
1	ZINC ALLOY	BLACK CHROME PLATING	3	ACRYLONITRILE BUTADIENE RUBBER	(GRAY)		
NO.	MATERIAL	FINISH , REMARKS	NO.	MATERIAL	FINISH , REMARKS		
UNITS mm		SCALE 2 : 1	COUNT 	DESCRIPTION OF REVISIONS	DESIGNED	CHECKED	DATE
<b>HIROSE ELECTRIC CO., LTD.</b>	APPROVED	·HY. KOBAYASHI	18.02.22	DRAWING NO.	EDC-110616-31-00		
	CHECKED	·HY. KOBAYASHI	18.02.22	PART NO.	JR25WCC-14(31)		
	DESIGNED	·TH. KAMEYA	18.02.21	CODE NO.	CL114-2066-0-31		
	DRAWN	·MK. INOUE	18.02.13		1/1		