

Technical Data Sheet:	DS576/0213
Product Description	Straight, fixed, external thread, Stainless Steel, SSU conduit fitting.
Product Range	SSU - S Type Stainless Steel fitting (Metric Threads)

Roman Way, Coleshill
Birmingham
B46 1HG, United Kingdom
Tel: 00 44 (0)1675 466900
Website: www.flexicon.uk.com

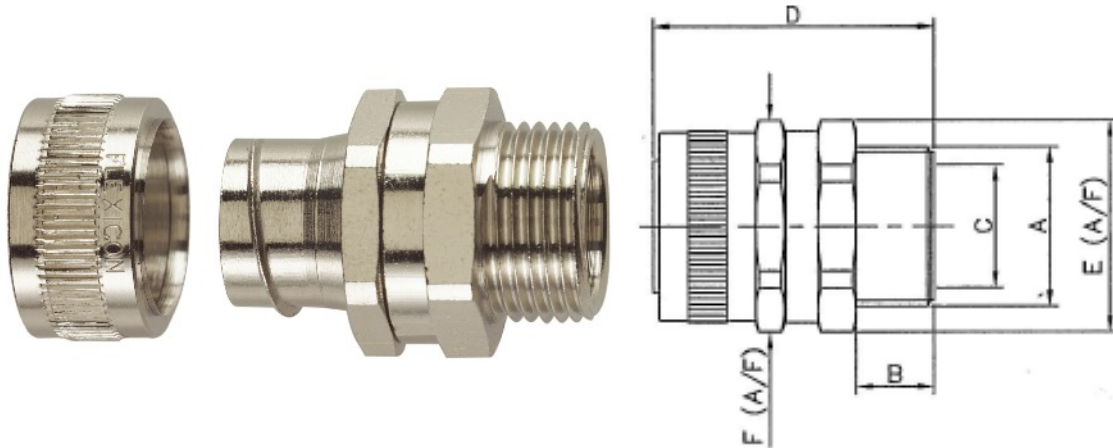

Material:

Stainless Steel (Grade 316)

Colour:

Self colour

Fire Performance:

Inherently Low Fire Hazard



IP Rating:

- IP40

Applications:

Suitable for knockouts and threaded entries

Two part fitting comprising of shell and body.

Features:

- High tensile strength
- Oil resistant
- Corrosion resistant
- Conforms to EN 61386

Note: also available in Nickel Plated Brass Versions.

Temperature Performance:

-100°C to +400°C

Conduit Size	Part No.	Metric Thread	Nominal Dimension (mm)				
		A	B	C	D	E	F
10	SSU10-M12-S	M12 X 1.5	8.0	5.6	30.2	14.0	14.0
12	SSU12-M16-S	M16 X 1.5	8.0	8.5	32.2	19.0	19.0
16	SSU16-M16-S	M16 X 1.5	10.0	11.5	34.2	19.0	19.0
20	SSU20-M20-S	M20 X 1.5	10.0	15.3	35.5	24.0	24.0
25	SSU25-M25-S	M25 X 1.5	10.0	19.1	43.7	28.6	28.6
32	SSU32-M32-S	M32 X 1.5	13.0	26.2	48.0	38.0	38.0

Compliance, Approvals & Accreditation;



IEC EN 61386



EN 61386 Classification Available on request

COMPLIANT TO LUL STANDARD 1-085-A3

London Underground Certificate No. 296

Typical Applications;



Construction



Rail



Machinery and OEM's



Defence

Errors, omissions and amendments excepted. As part of continuing product development Flexicon Ltd reserve the right to alter product specifications without prior notice. Data given is correct at time of compilation. Product specification and application data is for guidance only and does not constitute a warranty of any kind, either expressed or implied for Flexicon products or their suitability for a specific purpose. Third party approvals maybe limited to certain sizes within a product range.

Created by; Colin Legg - Marketing Manager	Approved by; Ian Gibson - Technical Director	Date; February 2013	Page Number; Page 1 of 1
--	--	-------------------------------	------------------------------------