

Motor Condition Monitoring Device

User's Manual K6CM

1
Overview

2
Device Components

3
Measuring and Monitoring System

4
Introduction of the Motor condition monitoring Tool

5
Installation and Wiring

6
How to Use the Motor condition monitoring Tool

7
Monitoring with K6CM and Motor condition monitoring Tool

8
Monitoring and Setting Using the EtherNet/IP Devices

9
Monitoring and Setting Using the Modbus TCP Devices

10
Trouble shooting

A
Appendices

I
Index



NOTE

All rights reserved. No part of this publication may be reproduced, stored in a retrieval system, or transmitted, in any form, or by any means, mechanical, electronic, photocopying, recording, or otherwise, without the prior written permission of OMRON.

No patent liability is assumed with respect to the use of the information contained herein. Moreover, because OMRON is constantly striving to improve its high-quality products, the information contained in this manual is subject to change without notice. Every precaution has been taken in the preparation of this manual. Nevertheless, OMRON assumes no responsibility for errors or omissions. Neither is any liability assumed for damages resulting from the use of the information contained in this publication.

Trademarks

- Microsoft, Windows is either registered trademarks or trademarks of Microsoft Corporation in the United States and other countries.
- CIP and EtherNet/IP™ are trademarks of ODVA.
- Modbus is a registered trademark or trademark of Schneider Electric USA, Inc. in Japan, the United States or other countries.

Other company names and product names in this document are the trademarks or registered trademarks of their respective companies.

Copyrights

Microsoft product screen shots reprinted with permission from Microsoft Corporation.

Preface

Thank you for purchasing K6CM Motor Condition Monitoring Devices.

This manual describes how to use the K6CM. Read this manual thoroughly and be sure you understand it before attempting to use the K6CM correctly according to the information provided. Keep this manual in a safe place for easy reference.

PDF version of this manual can be downloaded from the OMRON website.

(<http://www.omron.co.jp>)

Terms and Conditions Agreement

Warranty, Limitations of Liability

Warranties

● Exclusive Warranty

Omron's exclusive warranty is that the Products will be free from defects in materials and workmanship for a period of twelve months from the date of sale by Omron (or such other period expressed in writing by Omron). Omron disclaims all other warranties, express or implied.

● Limitations

OMRON MAKES NO WARRANTY OR REPRESENTATION, EXPRESS OR IMPLIED, ABOUT NON-INFRINGEMENT, MERCHANTABILITY OR FITNESS FOR A PARTICULAR PURPOSE OF THE PRODUCTS. BUYER ACKNOWLEDGES THAT IT ALONE HAS DETERMINED THAT THE PRODUCTS WILL SUITABLY MEET THE REQUIREMENTS OF THEIR INTENDED USE.

Omron further disclaims all warranties and responsibility of any type for claims or expenses based on infringement by the Products or otherwise of any intellectual property right.

● Buyer Remedy

Omron's sole obligation hereunder shall be, at Omron's election, to (i) replace (in the form originally shipped with Buyer responsible for labor charges for removal or replacement thereof) the non-complying Product, (ii) repair the non-complying Product, or (iii) repay or credit Buyer an amount equal to the purchase price of the non-complying Product; provided that in no event shall Omron be responsible for warranty, repair, indemnity or any other claims or expenses regarding the Products unless Omron's analysis confirms that the Products were properly handled, stored, installed and maintained and not subject to contamination, abuse, misuse or inappropriate modification. Return of any Products by Buyer must be approved in writing by Omron before shipment. Omron Companies shall not be liable for the suitability or unsuitability or the results from the use of Products in combination with any electrical or electronic components, circuits, system assemblies or any other materials or substances or environments. Any advice, recommendations or information given orally or in writing, are not to be construed as an amendment or addition to the above warranty.

See <http://www.omron.com/global/> or contact your Omron representative for published information.

Limitation on Liability; Etc

OMRON COMPANIES SHALL NOT BE LIABLE FOR SPECIAL, INDIRECT, INCIDENTAL, OR CONSEQUENTIAL DAMAGES, LOSS OF PROFITS OR PRODUCTION OR COMMERCIAL LOSS IN ANY WAY CONNECTED WITH THE PRODUCTS, WHETHER SUCH CLAIM IS BASED IN CONTRACT, WARRANTY, NEGLIGENCE OR STRICT LIABILITY.

Further, in no event shall liability of Omron Companies exceed the individual price of the Product on which liability is asserted.

Application Considerations

Suitability of Use

Omron Companies shall not be responsible for conformity with any standards, codes or regulations which apply to the combination of the Product in the Buyer's application or use of the Product. At Buyer's request, Omron will provide applicable third party certification documents identifying ratings and limitations of use which apply to the Product. This information by itself is not sufficient for a complete determination of the suitability of the Product in combination with the end product, machine, system, or other application or use. Buyer shall be solely responsible for determining appropriateness of the particular Product with respect to Buyer's application, product or system. Buyer shall take application responsibility in all cases.

NEVER USE THE PRODUCT FOR AN APPLICATION INVOLVING SERIOUS RISK TO LIFE OR PROPERTY OR IN LARGE QUANTITIES WITHOUT ENSURING THAT THE SYSTEM AS A WHOLE HAS BEEN DESIGNED TO ADDRESS THE RISKS, AND THAT THE OMRON PRODUCT(S) IS PROPERLY RATED AND INSTALLED FOR THE INTENDED USE WITHIN THE OVERALL EQUIPMENT OR SYSTEM.

Programmable Products

Omron Companies shall not be responsible for the user's programming of a programmable Product, or any consequence thereof.

Disclaimers

Performance Data

Data presented in Omron Company websites, catalogs and other materials is provided as a guide for the user in determining suitability and does not constitute a warranty. It may represent the result of Omron's test conditions, and the user must correlate it to actual application requirements. Actual performance is subject to the Omron's Warranty and Limitations of Liability.

Change in Specifications

Product specifications and accessories may be changed at any time based on improvements and other reasons. It is our practice to change part numbers when published ratings or features are changed, or when significant construction changes are made. However, some specifications of the Product may be changed without any notice. When in doubt, special part numbers may be assigned to fix or establish key specifications for your application. Please consult with your Omron's representative at any time to confirm actual specifications of purchased Product.

Errors and Omissions

Information presented by Omron Companies has been checked and is believed to be accurate; however, no responsibility is assumed for clerical, typographical or proofreading errors or omissions.

Safety Precautions

Definition of Precautionary Information





The following notation is used in this manual to provide precautions required to ensure safe usage of the K6CM Motor Condition Monitoring Devices.

The safety precautions that are provided are extremely important to safety. Always read and heed the information provided in all safety precautions.

The following notation is used.





 <b style="font-size: 24px; margin-left: 10px;">CAUTION	Indicates a potentially hazardous situation which, if not avoided, may result in minor or moderate injury or in property damage.
--	--











Symbols

Symbol	Meaning	
Caution		<ul style="list-style-type: none"> General Caution Indicates non-specific general cautions, warnings, and dangers.
		<ul style="list-style-type: none"> Electrical Shock Caution Indicates possibility of electric shock under specific conditions.
Prohibition		<ul style="list-style-type: none"> General Prohibition Indicates non-specific general prohibitions.
		<ul style="list-style-type: none"> Disassembly Prohibition Indicates prohibitions when there is a possibility of injury, such as from electric shock, as the result of disassembly.
Mandatory Caution		<ul style="list-style-type: none"> General Caution Indicates non-specific general cautions, warnings, and dangers.

 <b style="font-size: 24px; margin-left: 10px;">CAUTION
--

The following are common to the Motor Condition Monitoring Devices.

Electric shock or injury may occasionally occur. Follow the instructions below to use this product.	
Electrical shock may cause minor injury. Do not touch the product except for the front-panel buttons while electricity is being supplied.	
There is a risk of minor electrical shock, fire, or device failure. Do not allow any pieces of metal, conductors, or cutting chips that occur during the installation process to enter the product.	
Explosions may cause minor injuries. Do not use the product in locations with inflammable or explosive gases.	

 CAUTION	
There is a risk of minor electrical shock, fire, or device failure. Do not disassemble, modify, repair, or touch the inside of the product.	
If the product fails, monitoring and alarm outputs may fail to operate. This may result in physical damage to the facilities, equipment, or other devices that are connected to it. To reduce this risk, inspect the product regularly. To make the product fail-safe, take alternative safety measures, such as the installation of monitoring devices on a separate circuit.	
Incorrect wiring the input and output may occasionally result in fire and may occasionally occur resulting in property damage to connected equipment and machinery. Wire the input and output terminals correctly before power is supplied.	
If installation of wiring material is shallow, material damage due to ignition may occur in rare cases. When wiring, be sure to insert the wiring material all the way in.	
The following are for K6CM-C12 and K6CM-IS.	
Electric shock may occasionally occur. Follow the instructions below to use this product.	
Electric shock may occasionally occur. Always turn OFF the power supply before connecting the special CT or special ZCT (IRT).	
Electric shock may occasionally occur. As for the primary wire clamped with the special CT, be sure to use the insulated wires at temperatures below 65°C that have rated minimum 600 V and at least basic insulation. When clamping with conductive materials like busbar etc., use the special CT after ensuring equal to or more than basic insulation e.g. covering with insulating objects.	
Electric shock may occasionally occur. When wiring voltage input wires to the special ZCT (IRT), be sure to wire after checking that the system power supply is in non-energized state.	
Electric shock may occasionally occur. As for the wires for clamping with the special ZCT (IRT), be sure to use the insulated wires that have rated minimum 600 V and at least basic insulation.	
Keep the secondary terminal cover of the special CT and ZCT (IRT) securely closed. Touching any of electrode may result in electric shock.	

Conformance to Safety Standards

- Reinforced insulation is provided between input power supply, output, and between other terminals.
- To install a recommended fuse for this product according to the instruction manual is necessary.
- If the equipment is used in a manner not specified by the manufacturer, the protection provided by the equipment may be impaired.
- Connect the wiring of the special ZCT (IRT) to the terminal block corresponding to the thickness of AWG 18 or more.
- K6CM must be installed within a control panel as an embedded device, if using as a UL certified product.
- The motor rated voltage in regards to safety standard is as follows:

	K6CM-VB	K6CM-IS	K6CM-CI2
UL certification	480 V	480 V	480 V
Not UL certification	600 V	480 V	600 V

- K6CM is Over-voltage category II.
- K6CM will not conform to safety standards if attaching the vibration sensor with adhesive. In the case of disconnection, take safety measures such as fixing the cables.



Conformance to EN/IEC Standards

This is a class A product. In residential areas it may cause radio interference, in which case the user may be required to take adequate measures to reduce interference.



Precautions for Safe Use

Be sure to observe the following precautions to prevent malfunction or adverse affects on the performance or functionality of the product. Not doing so may occasionally result in unexpected events. Do not handle the K6CM in ways that exceed the ratings.

The followings are common to the Motor Condition Monitoring Devices.:

- (1) Do not use or store the product in the following locations:
 - Locations subject to water or oil (for K6CM devices and K6CM-VBS1 sensor preamplifier)
 - Outdoor or locations subject to direct sunlight
 - Locations subject to dust or corrosive gases (particularly sulfurizing gases, ammonia, etc.)
 - Locations subject to rapid temperature changes
 - Locations prone to icing and dew condensation
 - Locations subject to excessive vibration or shock
 - Locations subject to rain and wind damage
 - Locations subject to influence of static electricity and noise
 - Locations subject to bugs and small animals
- (2) Use and store the product in a location where the ambient temperature and humidity are within the specified ranges. If applicable, provide forced cooling.
- (3) Mount the product in the correct direction for installation.
- (4) Check terminal polarity when wiring and wire all connections correctly. The power supply terminals do not have polarity.
- (5) Do not wire the input and output terminals incorrectly.
- (6) Make sure the power supply voltage and loads are within the specifications and ratings for the product.
- (7) Make sure the crimp terminals for wiring are of the specified size.
- (8) Do not connect anything to terminals that are not being used.
- (9) Use a power supply that will reach the rated voltage within 1 second after the power is turned ON.
- (10) In order to prevent inductive noise, wire the lines connected to the product separately from power lines carrying high voltages or currents. Also, do not wire in parallel with or on the same cables as power lines. Other measures for reducing noise are to separate from ducts including noisy lines.
- (11) Do not install the product near equipment that generates high frequencies or surges.
- (12) Do not use the product near radio wave receivers. Doing so may cause incoming radio wave interference.
- (13) Install an external switch or a circuit breaker and label it clearly so that the operator can quickly turn OFF the power supply.
- (14) When discarding the product, properly dispose of it as industrial waste.
- (15) Make sure the LCD and the LEDs for output indicators operate correctly. Depending on the application environment, the indicators and other plastic parts may wear prematurely and become difficult to see. Check and replace these parts regularly.
- (16) The maximum terminal temperature is 80°C. Use wires with a heat resistance of 80°C min to wire the terminals.
- (17) Don't use because it may be damaged inside the product when the product fall by mistake.
- (18) Read this manual carefully before using the product.
- (19) Install product so that the load doesn't span the product body.
- (20) Be sure to use power terminals carefully, because power supply terminals have hazardous voltage. (for K6CM devices only. Except for K6CM-VBS1 sensors input.)
- (21) Only a professional with an understanding of electricity and electric devices must handle it.
- (22) Confirm the wiring the input and output terminals correctly before power is supplied.

- (23) Do not install the product close contact with the heating element.
- (24) Do not wire anything to the release holes.
- (25) Do not tilt or twist a flat-blade screwdriver while it is inserted into a release hole on the terminal block. The terminal block may be damaged.
- (26) Insert a flat-blade screwdriver into the release holes at an angle. The terminal block may be damaged if you insert the screwdriver straight in.
- (27) Do not allow the flat-blade screwdriver to fall out while it is inserted into a release hole.
- (28) The terminal block may be damaged if you insert a flat-blade screwdriver in the release hole with excessive force. When inserting a flat-blade screwdriver into the release holes, operate with a force of 15·N or less.
- (29) Do not bend a wire past its natural bending radius or pull on it with excessive force. Doing so may cause the wire disconnection.
- (30) Do not insert more than one wire into each terminal insertion hole.
- (31) To prevent wiring materials from smoking or ignition, use the wiring materials given in the following table.

Wire type	Wiring material	Recommended wires	Stripping length
			Without ferrules
Solid/ Stranded wire	Copper	0.25 to 1.5 mm ² AWG24 to AWG16	8 mm

- (32) Use the wire given in this manual.
- (33) When wiring, wire by enough length.
- (34) Follow the directions indicated in the manual for connecting EtherNet/IP™ or the cable. It may result in communications failure.
- (35) If EtherNet/IP™ tag data links (cyclic communications) are used with a repeating hub, the communications load on the network will increase. This will increase collisions and may prevent stable communications. Do not use repeating hubs on networks where tag data links are used. Use an Ethernet switch instead.
- (36) Do not continue to use the product if the front surface peels.

The followings are for K6CM-VB and K6CM-VBS1 sensors.

- (37) Protection structure of the sensor head/cable
Do not use the product in the condition that the protection structure is deteriorated, e.g., swelling or crack of housing material or sealing material. Continued use with deteriorated protective structure will cause cutting oil to enter inside the product, possibly destroying or burning.
- (38) Use the designated communications cable with the length between the sensor and the product within specification requirements.
- (39) Connect the preamplifier and the body after the power is turned OFF.

The followings are only for K6CM-CI2.

- (40) Open locking hook and clamp to each phase. After clamping, firmly engage until a sound is heard.
- (41) Use the special CTs and the CT cables that are specified by OMRON' s model number.
Special CTs (The cable is included with the special CT.):
K6CM-CICB005, K6CM-CICB025, K6CM-CICB100,
K6CM-CICB200, K6CM-CICB400, K6CM-CICB600

The followings are for K6CM-VB, K6CM-VBS1 sensors, K6CM-IS and ZCT(IRT).

- (42) Do not connect or disconnect the cables between the sensor and the product while power is being supplied. Doing so may result in malfunction or failure of the product.
- (43) Do not place heavy objects on the cables between the sensor and the Product, and do not apply excessive force to bend or pull the cables. Doing so may cause a failure.

The following is for K6CM-IS and K6CM-CI2.

- (44) The product is impossible to measure correctly in the state of open phase. Use the product in the state of non-open phase.

The following is only for K6CM-IS.

- (45) Use the product within the range of specifications and the rated input voltage.

Precautions for Correct Use

Observe the following operating methods to prevent failure and malfunction.

The followings are common to the K6CM.

- (1) Use the power supply voltage, input power, and other power supplies and transformers with suitable capacities and rated outputs.
- (2) When cleaning the product, do not use thinners or solvents. Use commercial alcohol.
- (3) Confirm that wire does not stick up after wiring of stranded cable.
- (4) In case of passage wiring, install these by 10 A per 1 terminal because when products are connected more than one in parallel, quite many electric currents to be called off.
- (5) The terminal block may be damaged if specialized tool is not used. Use a recommended flat-blade screwdriver to inserted into a release hole on the terminal block.
- (6) Do not apply excessive force to bend or pull the communications cables, and do not place heavy objects on the cables. Doing so will damage the cables.
- (7) Refer to the status information of the product on the data link communications and refer to the received data only in case of no errors occur with the product.

The followings are for K6CM-VB and K6CM-VBS1 sensors.

- (8) Wipe off the dirt on the mounting surface and screw mounting with 17 mm nominal size of wrench.
 - Recommended mounting screw tightening torque: 4.4 to 5.4 N•m
 - Mounting hole dimension: M6 holes (depth: 9 mm min.)
- (9) The easy-positioning magnet is for the purpose of seeking the detected position. In the case of using the product permanently, be sure to use it after it is mounted by screws.
- (10) In the case of vertical mounting or reverse mounting with the easy positioning magnet, be careful of the sensor falling.
- (11) Refer to *Installation of the Vibration Sensor Head* on page 5-7 to install the sensor correctly. It may be impossible to detect high frequency vibration.
- (12) Do not disassemble the sensor. It may not operate correctly.
- (13) Be careful of incorrect wiring or short circuit for wiring.
- (14) Do not use the preamplifier connected to the other products.
- (15) If there is a vibration reduction device such as dampers and rubbers between the vibration measurement object and the sensor, it is difficult to detect the vibration and it will not be able to measure it correctly, so do not install as much as possible.
- (16) In the case of insertion and removal of connector, be sure to do it by holding the connector with hands.
- (17) Do not remove the connector with holding the cable.
- (18) Check the direction of the key groove before you use the connector.
- (19) Do not wire with wet hands. It may result in operation failure or product damage when power is being supplied to the product.
- (20) When fitting the connector, be sure to do it with hands, not to use tools. It may result in damages if the tool like plier is used.
- (21) In the case of removal of the fitness of the connector between the sensor and the preamplifier, be careful to do it not to adhere water or dirt on the fitting surface. It may result in faulty contact at the connector.
- (22) Install cables to avoid any force is applied to the connector. In case the any force is applied to the connector, it causes that the performance of protection structure becomes incapable.
- (23) Do not use the connector as a scaffold or put heavy objects on it. It may result in connector damage.

- (24) Do not mount the way that the force is directly applied to the fitting part of the connector or the root part of the cable connection. It may result in connector damage or cable disconnection.
- (25) When bending cables, use cables with a minimum bending radius of 25 mm.
- (26) Use preamplifier after it is fixed on the DIN rail or with screws. In case of using unfixed one, it is in the condition that force is easily applied to the cable, and the cable may be broken.
- (27) About oil-resistance of sensor head/cable; (Not tested by UL)
Follow the procedure below in case of using the product under the condition that uses cutting oil since the life expectancy and the performance of the product are affected.
- Use the product in the specified condition for cutting oil
 - Use the product at the dilution rate of cutting oil that is recommended by the cutting oil makers.
 - Do not use the product in oil or water.
- There are cases that the influence on the life expectancy of the product differs depending on the type of the use oil. Make sure in advance that there is no deterioration of the sealing material by the cutting oil, before using the product.
- (28) Do not use the alarm output function for control. This function can be used only to detect abnormal conditions and to output the alarm.
- (29) Avoid using the product in places near a radio, a television set, or a wireless device.
The product may result in radio disturbance for these devices.

The followings are only for K6CM-IS.

- (30) Do not clamp directly to the lines exceeding 480 VAC. UL certification complies with 480 VAC.
- (31) Use the special ZCT (IRT) after fixing it with screws. If used without fixing, a load is easily applied on the cable, and the cable may become disconnected.
- (32) ZCT (IRT) is a special product. Do not use it for any other purposes. Otherwise, failure may occur.
- (33) When clamping wires with special ZCT (IRT), do it in a right direction. If clamped in the wrong direction, correct measurement cannot be taken.
- (34) The distorted ratio of the input waveform should be 30% or less. If it is used in a circuit with large distortion of waveform, it may cause unnecessary operation.
- (35) Do not use in a circuit with the waveform is distorted. The error will increase due to the influence of the distorted waveform.

The followings are only for K6CM-C12.

- (36) Make sure that the rating of the used special CT and the special CT setting of the product agree.
- (37) Do not ground the special CT. Doing so may cause instability when measuring failure.
- (38) Do not clamp directly to the lines exceeding 600 VAC. UL certification complies with 480 VAC.
- (39) Place the cable between the special CT and the product at a distance of 6 mm or more from other cables.
- (40) Associated leads of the special CT shall be maintained within the same overall enclosure.
- (41) The special CT are intended for installation within the same enclosure as the equipment. These may not be installed within switchgears and panel boards.

Manual Structure

Page Structure

The following page structure is used in this manual.

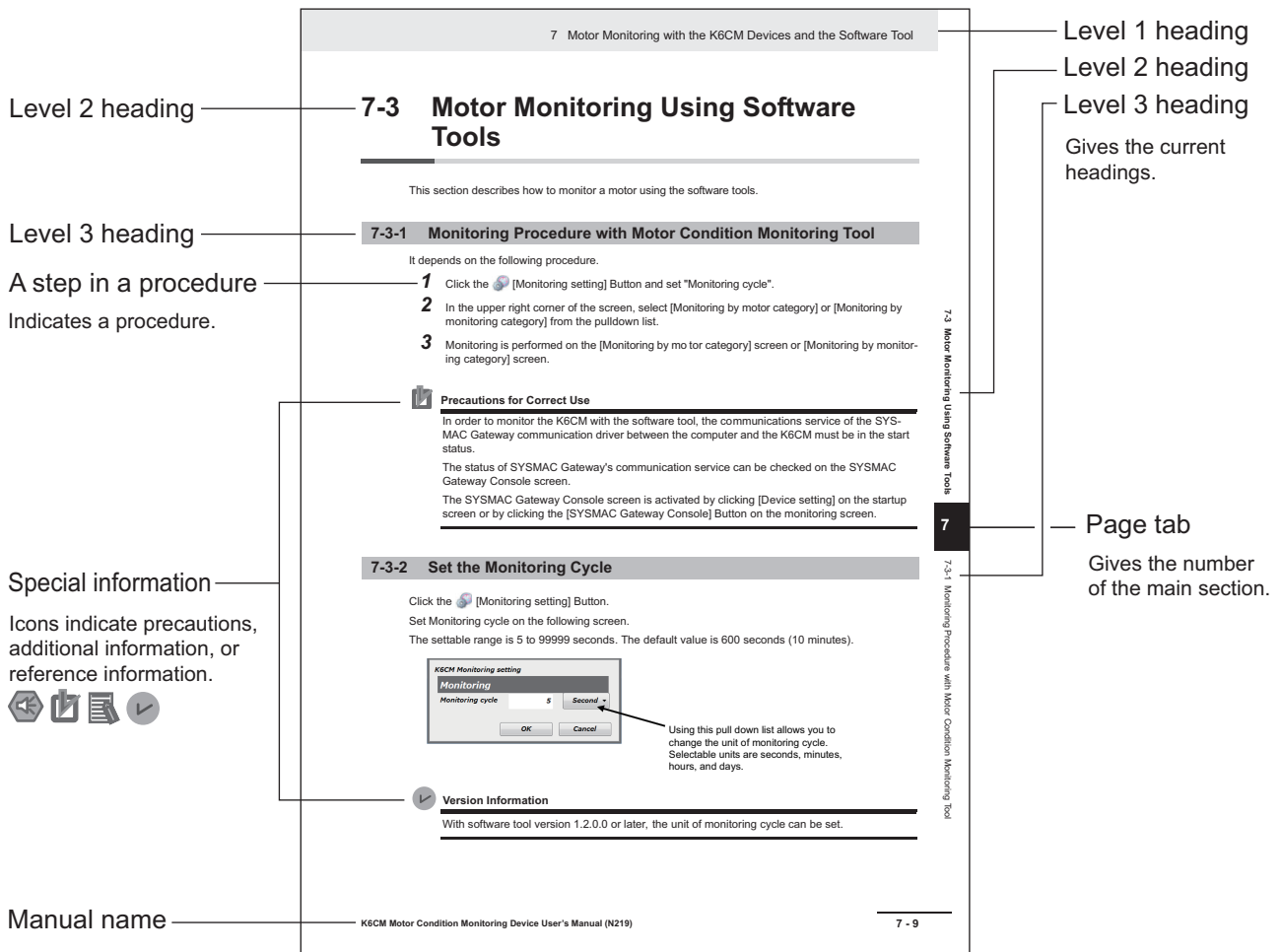

Special Information

Special information in this manual is classified as follows:



Precautions for Safe Use

Precautions on what to do and what not to do to ensure safe usage of the product.



Precautions for Correct Use

Precautions on what to do and what not to do to ensure proper operation and performance.



Additional Information

Additional information to read as required.

This information is provided to increase understanding or make operation easier.



Version Information

Information on differences in specifications and functionality for CPU Units with different unit versions and for different versions of the Sysmac Studio is given.

Note References are provided to more detailed or related information.

Revision History

A manual revision code appears as a suffix to the catalog number on the front cover of the manual.

Man.No.	N219-E1-12
----------------	-------------------

↑
Revision code

Revision code	Date	Revised content
01	December 2017	Original production
02	December 2017	Added descriptions and corrected mistakes.
03	December 2017	Added descriptions and corrected mistakes.
04	April 2018	Added descriptions and corrected mistakes.
05	April 2018	Corrected mistakes.
06	June 2018	<ul style="list-style-type: none"> • Added descriptions about the selection function of the Transistor output method with the version upgrade of the software tool Motor condition monitoring Tool (version 1.0.0.2 to 1.1.0.0) • Added following functions according to the upgrade of the Eip cpu version (version 1.00 to 1.10) of the K6CM device <ul style="list-style-type: none"> • Selection function of the Transistor output method (Not that it can be selected only when using the software tool Motor condition monitoring Tool version 1.1.0.0 or higher.) • Trigger function with the external input of the insulation resistance type K6CM-ISM device • Corrected mistakes.
07	October 2018	<ul style="list-style-type: none"> • Added descriptions about the following functions according to the upgrade version of the software tool Motor condition monitoring Tool (version 1.1.0.0 to 1.2.0.0) <ul style="list-style-type: none"> • Graph vertical axis scale setting • Graph time axis movement • IP address list display • Added descriptions according to the adhesive attachment which is sold separately for a vibration sensor. • Corrected mistakes. • Added descriptions.
08	December 2018	<ul style="list-style-type: none"> • Deleted the descriptions of "Adhesive attachment will be released soon" • Corrected mistakes.
09	December 2018	<ul style="list-style-type: none"> • Added descriptions on the multicast of tag data link. • Added a side-view dimensions of adhesive attachment.
10	April 2019	<ul style="list-style-type: none"> • Changed descriptions on multicast communications of tag data link. • Corrected mistakes.
11	May 2019	<ul style="list-style-type: none"> • Added descriptions on the degradation level in motor or load imbalance when the motor is driven with an inverter. • Added description on the monitoring cycle of the motor condition monitoring tool. • Corrected mistakes.

12	April 2020	<ul style="list-style-type: none">• Changed descriptions due to upgrading the comprehensive current diagnosis model from K6CM-CIM to K6CM-CI2M.• Upgrade version of the software tool Motor condition monitoring Tool. (version 1.2.0.0 to 1.3.0.0)• Corrected mistakes.
----	------------	--

Sections in this Manual

1	Overview	A	Appendices	1	A
2	Device Components	I	Index	2	I
3	Monitoring System			3	
4	Introduction of the Motor condition monitoring Tool			4	
5	Installation and Wiring			5	
6	How to Use the Motor condition monitoring Tool			6	
7	Monitoring with K6CM and Motor condition monitoring Tool			7	
8	Monitoring and Setting Using the EtherNet/IP Devices			8	
9	Monitoring and Setting Using the Modbus TCP Devices			9	
10	Trouble shooting			10	

CONTENTS

Preface	1
Terms and Conditions Agreement.....	2
Warranty, Limitations of Liability	2
Application Considerations	3
Disclaimers	3
Safety Precautions	4
Definition of Precautionary Information.....	4
Symbols	4
Precautions for Safe Use	7
Precautions for Correct Use.....	10
Manual Structure	12
Page Structure.....	12
Special Information	13
Revision History	14
Sections in this Manual	17
CONTENTS.....	18

Section 1 Overview

1-1 Overview.....	1-2
1-1-1 What is the K6CM Motor Condition Monitoring Devices For?	1-2
1-2 Features.....	1-3
1-2-1 Features Common for All Models.....	1-3
1-2-2 Overview and Features of the Comprehensive Current Diagnosis Type	1-4
1-2-3 Features of Vibration & Temperature Type.....	1-6
1-2-4 Features of Insulation Resistance Type.....	1-6
1-2-5 Features of Software Tool.....	1-6
1-3 List of Models	1-7
1-3-1 Model Number Legend.....	1-7
1-3-2 List of Models	1-8
1-4 System Configurations	1-9
1-4-1 Overall System Configuration	1-9
1-4-2 I/O Configuration by Monitor Type	1-10
1-5 Procedure.....	1-14

Section 2 Device Components

2-1 Overview of K6CM Device	2-2
2-1-1 K6CM Device	2-2
2-1-2 Label of the K6CM Device	2-2
2-2 Nomenclature and Functions of the K6CM Device	2-3
2-2-1 K6CM Device	2-3
2-2-2 Transition of Numeric LCD Display	2-8
2-2-3 Status of Alarm Bar, Status Indication, and Transistor Output for Each Status	2-9

2-3	Special CT	2-10
2-4	Vibration & Temperature Sensor	2-11
2-5	Insulation Resistance Sensor (Special ZCT (IRT))	2-13

Section 3 Measuring and monitoring System

3-1	Internal mechanism of K6CM	3-2
3-1-1	Measuring and monitoring by K6CM	3-2
3-2	Measurement System.....	3-3
3-2-1	Sampling of measurement values	3-3
3-2-2	Moving average	3-4
3-2-3	Monitoring Delay.....	3-4
3-2-4	Trigger Mode	3-5
3-2-5	Maximum Value and Minimum Value of Measurement value.....	3-11
3-3	Monitoring System	3-13
3-3-1	Types of Individual Alarms.....	3-13
3-3-2	What is Comprehensive Alarm?	3-13
3-3-3	Relationship Between Alarm and Display/Output.....	3-14
3-4	Guide for Setting Alarm	3-19
3-4-1	Comprehensive Current Diagnosis Type (K6CM-CI2).....	3-19
3-4-2	Vibration & Temperature Type (K6CM-VB)	3-23
3-5	How the Self-Diagnosis Function Works	3-25
3-6	How the Replacement Timing Notification (i.e., Running Time Function) Works	3-27
3-7	Initialization of Setting Value.....	3-28

Section 4 Introduction of the Motor condition monitoring Tool

4-1	Overview.....	4-2
4-1-1	What is the Motor condition monitoring Tool (Software Tool) for?.....	4-2
4-1-2	Functions and Specifications of the Software Tool.....	4-3
4-1-3	Operating Environment of the Software tool.....	4-8
4-2	Installation and Uninstallation, Starting up	4-10
4-2-1	Installation.....	4-10
4-2-2	Uninstallation Procedures.....	4-23
4-3	IP Address Setting.....	4-24
4-3-1	IP Address Setting of Your PC	4-24
4-3-2	IP Address Setting of the K6CM Devices	4-26

Section 5 Installation and Wiring

5-1	Dimensions	5-2
5-1-1	K6CM device	5-2
5-1-2	Special CT	5-2
5-1-3	Vibration & temperature Sensor	5-3
5-1-4	Insulation resistance sensor (special ZCT (IRT))	5-4
5-2	Installation.....	5-5
5-2-1	Precautions at installation.....	5-5
5-2-2	Installing the K6CM Device.....	5-5
5-2-3	Installation of the Vibration & Temperature sensor.....	5-7
5-2-4	Installation of the insulation resistance sensor (special ZCT (IRT))	5-13
5-2-5	Installation of the special CT.....	5-15

5-3	How to Connect to the Vibration & Temperature Sensor	5-16
5-3-1	When Connecting Directly to the K6CM Device.....	5-16
5-3-2	When Connecting by Extending the Cable	5-17
5-3-3	Recommended Ferrules and Crimp Tool.....	5-18
5-4	How to Connect to the Push-In Plus Terminal Blocks.....	5-19
5-4-1	the Push-In Plus Terminal Block.....	5-20
5-4-2	How to use the Push-In Plus Terminal Block.....	5-20
5-4-3	Recommended Ferrules and Crimp Tools	5-22
5-5	Diagram of Terminal Description	5-24
5-6	I/O wiring	5-25
5-7	Network Wiring	5-29

Section 6 How to Use the Motor condition monitoring Tool

6-1	Screens.....	6-2
6-1-1	Start Screen	6-2
6-1-2	Monitoring Screen and Setting Screen	6-5
6-1-3	Common Menu and Toolbar List.....	6-11
6-1-4	Buttons on Device Setting.....	6-13
6-1-5	Software Tool Version Display Screen.....	6-18
6-2	Setting of K6CM Devices	6-19
6-2-1	Settings for Each Monitor Type of K6CM devices.....	6-19
6-2-2	Setting Parameters	6-23
6-2-3	Add a Device to an Existing Project.....	6-24
6-2-4	Motor (Device Group) Rename.....	6-25
6-2-5	Save Overwriting Project.....	6-26
6-2-6	Exit Project.....	6-26

Section 7 Monitoring with K6CM and Motor condition monitoring Tool

7-1	Motor Monitoring and Operation Procedure.....	7-2
7-2	Motor Monitoring Using the K6CM devices	7-3
7-2-1	Start measurement.....	7-3
7-2-2	Monitoring Type Switching.....	7-5
7-2-3	Monitoring method	7-6
7-2-4	Monitoring Completed	7-8
7-3	Motor Monitoring Using Software Tools	7-9
7-3-1	Monitoring Procedure with Motor Condition Monitoring Tool	7-9
7-3-2	Set the Monitoring Cycle.....	7-9
7-3-3	Start Monitoring.....	7-10
7-3-4	Saving Log Files.....	7-11
7-3-5	Graph Vertical Axis Scale Setting	7-12
7-3-6	Graph Time Axis Movement.....	7-13

Section 8 Monitoring and Setting Using the EtherNet/IP Devices

8-1	Overview.....	8-2
8-1-1	What is Monitoring Using EtherNet/IP?.....	8-2
8-1-2	EtherNet/IP Communications Specifications.....	8-4
8-2	Monitoring Using the Tag Data Link	8-5
8-2-1	Connection setting	8-5
8-2-2	Data to be Tag Data Link Target in the K6CM Device	8-9

8-3	Monitoring and Setting Using the CIP Message Communications and Examples of Communications Instructions	8-12
8-3-1	Datatype List of Variables.....	8-12
8-3-2	Services Supported by Objects in K6CM.....	8-12
8-3-3	Monitor Object (Class ID: 370 hex).....	8-13
8-3-4	Setting Object (Class ID: 371 hex).....	8-18
8-3-5	Identity Object (Class ID: 01 hex).....	8-24
8-3-6	TCP/IP Interface Object (Class ID: F5 hex).....	8-26
8-3-7	Examples of CIP Message Communications Instruction.....	8-28
8-4	Sample Program for the NJ/NX-series	8-30
8-4-1	Sample Program Overview.....	8-30
8-4-2	Sample Program Processing Flow and Function Block Specifications.....	8-33
8-4-3	Sample Program Execution Procedures.....	8-39
8-4-4	Sample Program Code Descriptions.....	8-40

Section 9 Monitoring and Setting Using the Modbus TCP Devices

9-1	Outline	9-2
9-2	Function Codes	9-3
9-2-1	Function Code List.....	9-3
9-2-2	03 hex: Reading of Multiple Registers.....	9-3
9-2-3	06 hex: Operation Command.....	9-5
9-2-4	10 hex: Writing of Multiple Registers.....	9-6
9-2-5	Exception Code List.....	9-7
9-3	Register Address Lists	9-8
9-3-1	Monitoring Information.....	9-8
9-3-2	Setting Information.....	9-12
9-3-3	Product Information.....	9-18
9-3-4	IP Address.....	9-18
9-3-5	Operation Command.....	9-19
9-3-6	Modbus TCP Connection Timeout Time.....	9-19

Section 10 Trouble shooting

10-1	K6CM Devices	10-2
10-2	Using the Software tool	10-4
10-3	Using the Ethernet communications	10-6

Appendices

A-1	Specifications	A-2
A-2	Measurement values by Each Monitor Type	A-3
A-3	K6CM Common Specifications	A-4
A-4	K6CM device Individual Specifications	A-8
A-5	Individual Specifications of the Dedicated Sensor	A-10
A-6	Internal Data of K6CM Devices	A-14
A-7	Setting Values	A-15
A-8	Present Values	A-21
A-9	Tag Data Link Connection Setting Procedures	A-26
A-9-1	Using the CS/CJ-series.....	A-26
A-9-2	Using the NJ/NX-series.....	A-38

A-10 Expansion Error Code of the CIP Message CommunicationsA-48
A-10-1 General StatusA-48
A-10-2 Additional Status When General Status Is 01 hexA-50

A-11 Version CompatibilityA-51
A-11-1 Version Upgrades of the K6CM SeriesA-51
A-11-2 Support Correspondence between the K6CM Device and Motor Condition Monitoring Tool ...A-51
A-11-3 Motor Condition Monitoring Tool Version CompatibilityA-52
A-11-4 BOOTP Server Connection Error State LED Lighting Differences.....A-52

Index

1

Overview

This section describes an overview, the features, the models, the system configurations, and the procedures of the K6CM Motor Condition Monitoring Device.

1-1 Overview	1-2
1-1-1 What is the K6CM Motor Condition Monitoring Devices For?	1-2
1-2 Features	1-3
1-2-1 Features Common for All Models	1-3
1-2-2 Overview and Features of the Comprehensive Current Diagnosis Type	1-4
1-2-3 Features of Vibration & Temperature Type	1-6
1-2-4 Features of Insulation Resistance Type	1-6
1-2-5 Features of Software Tool	1-6
1-3 List of Models	1-7
1-3-1 Model Number Legend	1-7
1-3-2 List of Models	1-8
1-4 System Configurations	1-9
1-4-1 Overall System Configuration	1-9
1-4-2 I/O Configuration by Monitor Type	1-10
1-5 Procedure	1-14

1-1 Overview

This section describes an overview and features of the K6CM.

1-1-1 What is the K6CM Motor Condition Monitoring Devices For?

K6CM Motor Condition Monitoring Device is a device that visualizes and monitors the state of the motor by measuring the feature quantity of the three-phase induction motor. Motors other than three-phase induction motors (e.g., synchronous motor, single phase motor, servo motor, stepping motor) are excluded.

Depending on the feature quantity to be measured, you can select from the following three types.

Type	Outline	Feature quantity measured
Comprehensive current diagnosis type K6CM-C1M K6CM-C12M	Measures the current waveform of a motor and the current waveform of an inverter driving motor and monitors the distortion of the current waveforms as the degradation levels.	Measures the degradation levels*1 and current of the motor.
Vibration & temperature type K6CM-VBM	Monitors motor bearing abnormalities from the vibration and temperature.	Measures the motor vibration (acceleration and velocity) and motor temperature.
Insulation resistance type K6CM-ISM	Monitors the motor insulation resistance.	Measures the insulation resistance.

*1. Two degradation levels, degradation level 1 and degradation level 2, are measured by using different algorithms.

The K6CM-C1M measures only degradation level 1, so it is referred to as the degradation level in the software tool.

By properly using these three types as necessary, you can catch the state of the induction motor and decide the appropriate maintenance time.

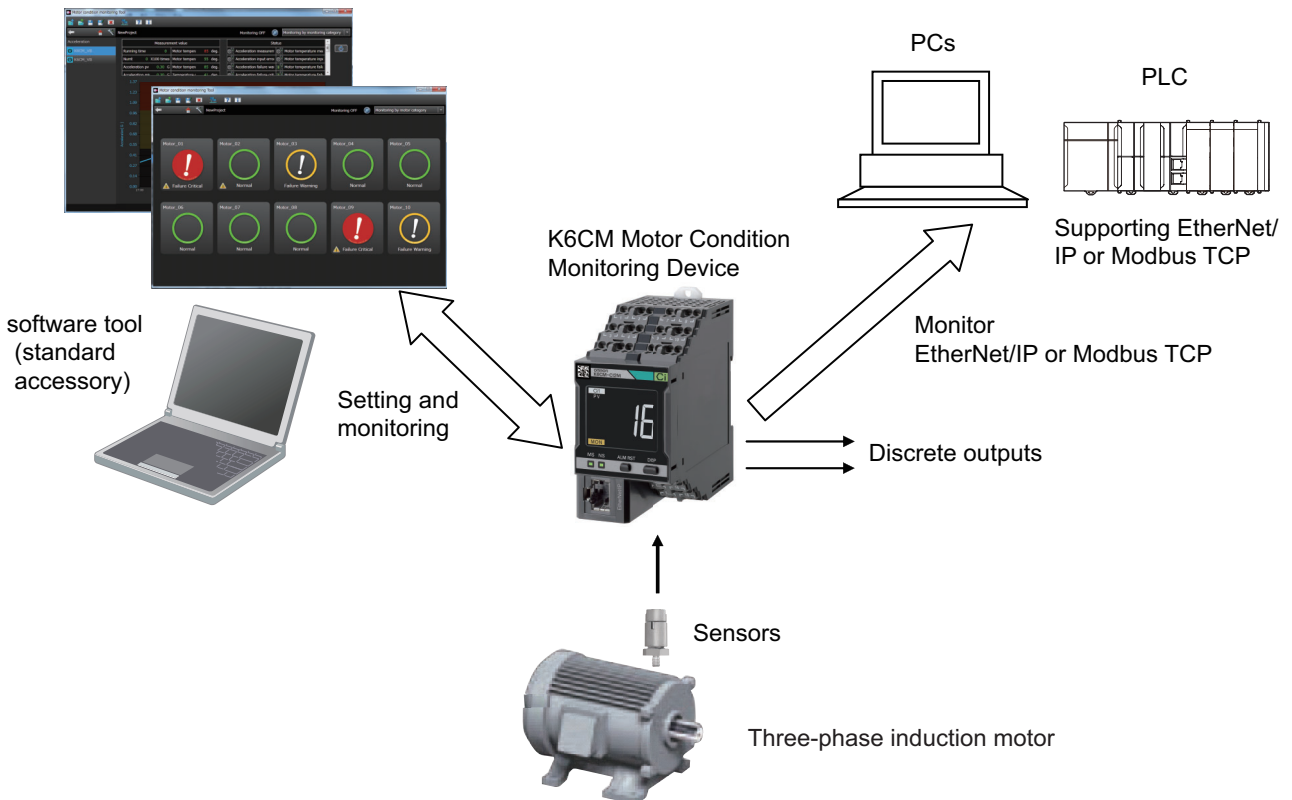

1-2 Features

1-2-1 Features Common for All Models

- Multiple K6CM devices can be connected to one PLC or one PC, and multiple motor statuses can be monitored at one time.
 - Status monitoring can be confirmed on site easily from the alarm bar display and numeric LCD display on the front of the K6CM device.
 - Two levels of warning failure and critical failure are prepared as alarm monitoring levels. Two outputs of the transistor are possible when the alarm occurs.
 - A self-diagnosis function and replacement timing notification are incorporated. With these functions, errors of the K6CM device and when to be replaced can be determined.
 - Trigger functions using an external input or internal set value comparison enable monitoring only when specified conditions such as startup of the motor are met. In addition, the maximum and minimum values can be automatically calculated and output during the period that those conditions are met. (*1)
 - EtherNet/IP (i.e., tag data link, CIP message communications) is supported. Measurement values and internal data can be read, and alarm setpoints and other set values can be written from the PLC or PC. (*2)
- *1. For the insulation resistance type K6CM device, the trigger function using the external input can be supported for the Eip cpu version 1.10 or higher.
- *2. Tag data link can be read only. Write not possible.

Features of Main CPU Version 1.2 or Later

- Measurement is possible in a stable state even after starting up the motor using the trigger function following a monitoring delay time.
- Modbus TCP is supported. Measurement values and internal data can be read, and alarm setpoints and other set values can be written from the PLC or PC by using message communications.
- The indication for the unit of measurement value (monitoring type) on the K6CM device numeric LCD display can be switched automatically at a 5-second interval. This allows you to confirm status monitoring without touching the operation keys of the K6CM device.

1-2-2 Overview and Features of the Comprehensive Current Diagnosis Type

Overview

The current waveform of the motor is a smooth sine wave if the motor and load are in the normal ideal states. If the motor or load are abnormal, noise appears in the current waveform as shown below.

(1) Motor and load are normal.

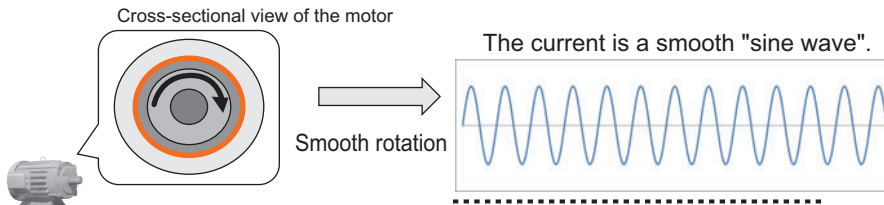

(2) An abnormality is occurring.

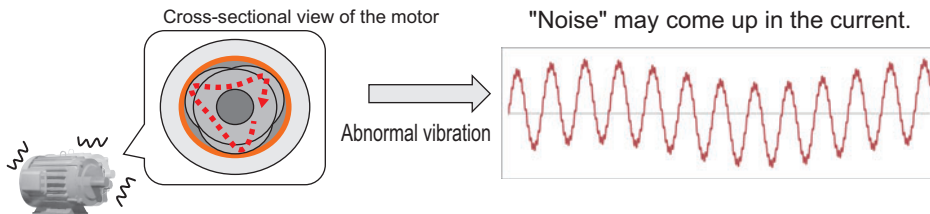

Abnormality affecting degradation level	Major factors
Misalignment	Coupling abnormal, centering shortage, etc.
Load imbalance	Unbalance of rotating objects such as fans
Rotor abnormality	Breakage inside the motor
Cavitation, air contamination	Vacuum bubbles in water stream, pipe internal pressure drop, etc.
Overload	Excessive rotational load

Note The degradation level may appear differently depending on the failure condition of the motor or load, or depending on the installation condition.

Features

- A motor error can be detected by representing the degree of deviation of the current waveform between a normal motor and an abnormal motor in numerical values (as degradation level 1).
- A motor error can be detected by analyzing the frequency components affecting the rotating shaft of the motor and representing them in numerical values. It is suitable for monitoring of inverter drive (as degradation level 2).
- Degradation levels 1 and 2 can be monitored simultaneously. (The K6CM-CIM can only monitor degradation level 1.)
- The K6CM can also detect motor peripheral malfunctions affecting the rotating shaft of the motor.

● Mechanism of degradation level 1

For degradation level 1, the K6CM device compares the current waveform of the motor with the smooth sine wave of the ideal state, and represents the degree of deviation from the smooth sine wave in numerical values. If the motor or load is abnormal, that degree of deviation will be large, and the value of degradation level 1 will be large.

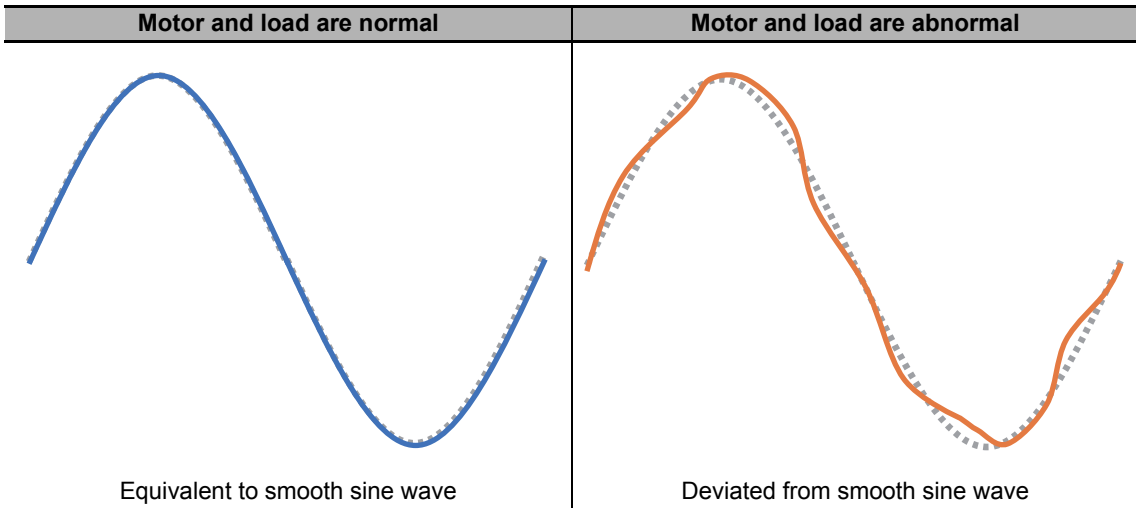

If the current waveform of the motor contains many noise components such as with inverter driving, the value of degradation level 1 will be large because there will be deviation from the ideal state even if the motor and load are normal. Therefore, the difference between the normal state and abnormal state will be small.

● Mechanism of degradation level 2

For degradation level 2, the K6CM device determines what percentages of the frequency components affecting the rotating shaft of the motor were included in the drive frequency components when frequency analysis was performed on the current waveform of the motor, and represents them in numerical values. If the motor or load is abnormal, the frequency components affecting the rotating shaft of the motor will be large, and the value of degradation level 2 will be large.

Since the frequency components affecting the rotating shaft of the motor are clearly captured and represented as numerical values, even in environment with many noise components such as inverter driving, a motor or load abnormality is captured with excellent sensitivity and the variations in the numerical values tend to be also small compared with degradation level 1. Therefore, it is suitable for monitoring an inverter-driven three-phase induction motor.

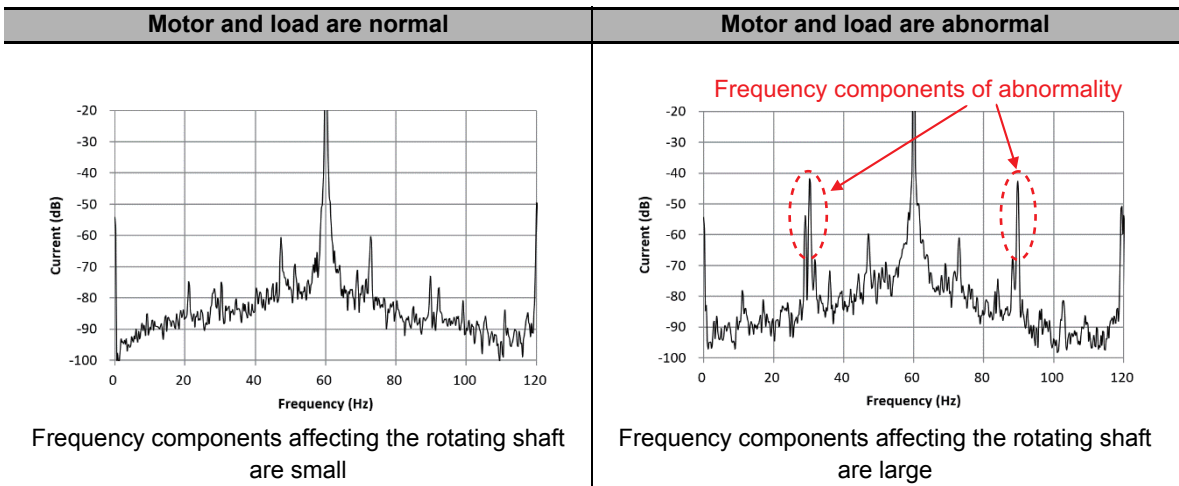

1-2-3 Features of Vibration & Temperature Type

- Simultaneous monitoring of motor vibration (i.e., acceleration and velocity) and motor temperature are possible.
- Mainly bearing wears can be detected by the acceleration.
- Mainly load imbalance and misalignment can be detected by the velocity.
- The acceleration and velocity alarm threshold values of K6CM-VBM vibration & temperature type can be set automatically with the software tool (software tool version 1.3.0.0 or later).

1-2-4 Features of Insulation Resistance Type

- Insulation resistance can be monitored.
- Resistance leakage current (I0r) can be measured. (*1)
- Capacitive leakage current (I0c) can also be measured. (*2)

*1. Alarm output cannot be performed.

*2. Can be read via EtherNet/IP or Modbus TCP. Unit display and alarm output cannot be performed.

1-2-5 Features of Software Tool

- Software tool "Motor condition monitoring Tool" that is provided with the K6CM device enables K6CM device setup and simple status monitoring.
- It enables reading of measurement values at specified intervals and automatic data storage (with the CSV format).
- The acceleration and velocity threshold values can be set automatically (software tool version 1.3.0.0 or later).

1-3 List of Models

This section shows the model number legend of the K6CM devices, and models of the K6CM devices and the dedicated sensors.

1-3-1 Model Number Legend

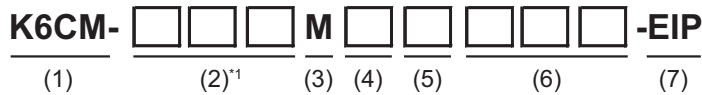

(1)	(2)	(3)	(4)	(5)	(6)	(7)	Function
Base model	Detection type	Product classification	Power specification	Options	Special specifications	Communications	
K6CM	CI ^{*2} CI2 VB IS	M	A D	Not used	Not used	EIP	Motor Condition Monitoring Device
							Comprehensive current diagnosis type
							Comprehensive current diagnosis type 2
							Vibration & temperature type
							Insulation resistance type
	Not used						K6CM device
							100 to 240 VAC
							24 VAC/VDC
							Not used
							Not used
							EtherNet/IP and Modbus TCP

*1. For other than detection type CI2, this is 2 digits so read it with the 3rd digit truncated.
 *2. The detection type CI2 is an upward compatible model of CI, so CI is planned to be integrated into CI2. In the following description, the model name CI is referred to as CI2.

1-3-2 List of Models

Comprehensive Current Diagnosis Type

	Model	Specifications such as power supply voltage
K6CM device	K6CM-CIMA-EIP	100 to 240 VAC
	K6CM-CIMD-EIP	24 VAC/VDC
	K6CM-CI2MA-EIP	100 to 240 VAC
	K6CM-CI2MD-EIP	24 VAC/VDC
Sensor (special CT)	K6CM-CICB005	Rated primary current: 5 A, rated voltage: 480 VAC
	K6CM-CICB025	Rated primary current: 25 A, rated voltage: 480 VAC
	K6CM-CICB100	Rated primary current: 100 A, rated voltage: 480 VAC
	K6CM-CICB200	Rated primary current: 200 A, rated voltage: 480 VAC
	K6CM-CICB400	Rated primary current: 400 A, rated voltage: 480 VAC
	K6CM-CICB600	Rated primary current: 600 A, rated voltage: 480 VAC

Vibration & Temperature Type

	Model	Specifications such as power supply voltage
K6CM device	K6CM-VBMA-EIP	100 to 240 VAC
	K6CM-VBMD-EIP	24 V AC/DC
Sensor (sensor head and pre-amplifier)*1	K6CM-VBS1	Mounting: M6 screw
Adhesive attachment	K6CM-VBSAT1	Material: Stainless steel

*1. The sensor head and the pre-amplifier are calibrated and inspected as a set at the factory shipment. Be sure to use them with the combination shipped.

Insulation Resistance Type

	Model	Specifications such as power supply voltage
K6CM device	K6CM-ISMA-EIP	100 to 240 VAC
	K6CM-ISMD-EIP	24 V AC/DC
Sensor (special ZCT (IRT)) *1	K6CM-ISZBI52	Rated voltage: 200 to 480 VAC, through hole diameter 52 mm

*1. ZCT (IRT) stands for Zero Current Transformer (Insulation Resistance Transformer).

1-4 System Configurations

This section describes the overall system configurations of the K6CM and the I/O configuration for each monitor type of K6CM devices.

1

1-4-1 Overall System Configuration

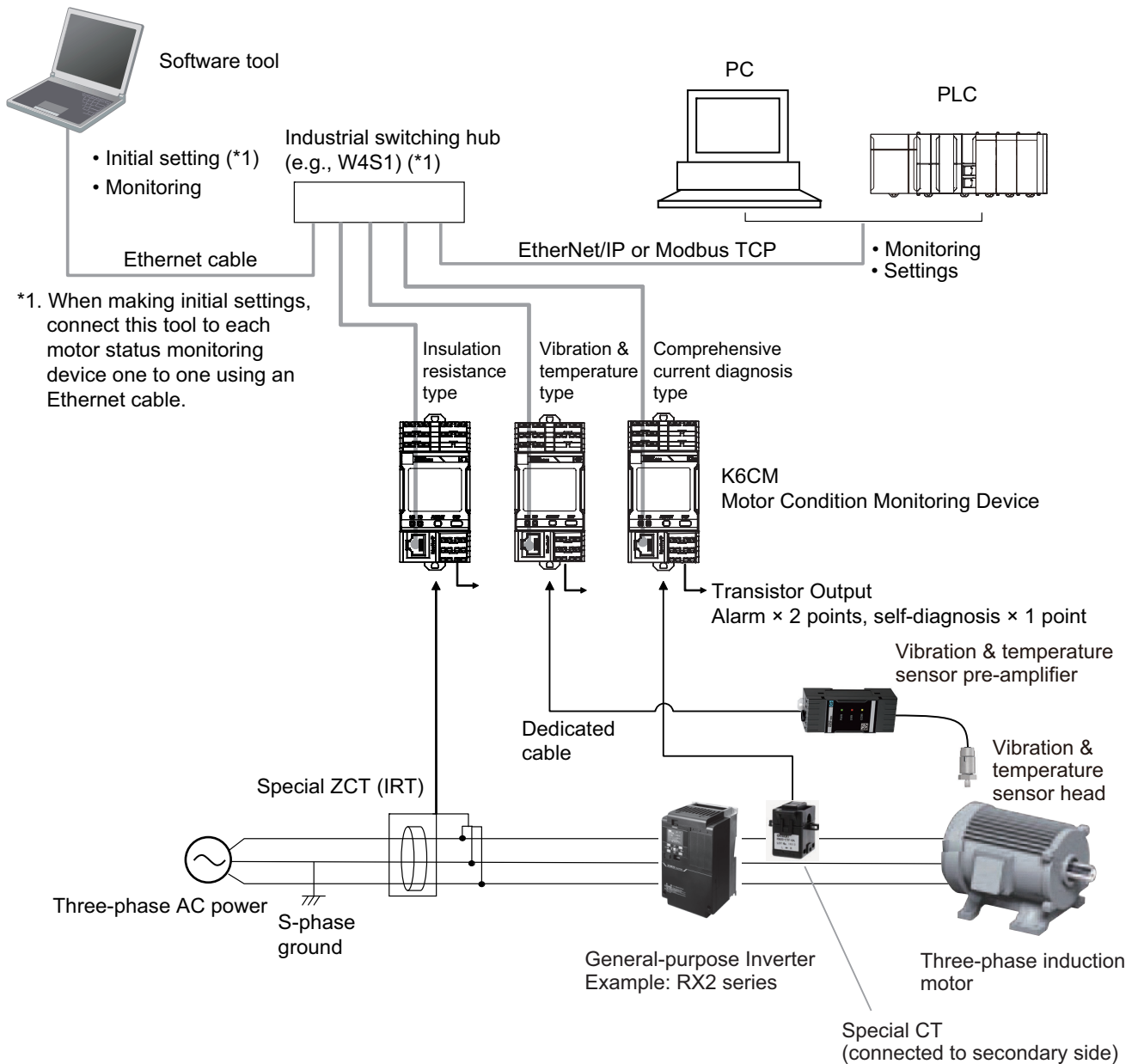

1-4-2 I/O Configuration by Monitor Type

K6CM-CI2 Comprehensive Current Diagnosis Type

- Three-phase induction motor connection example

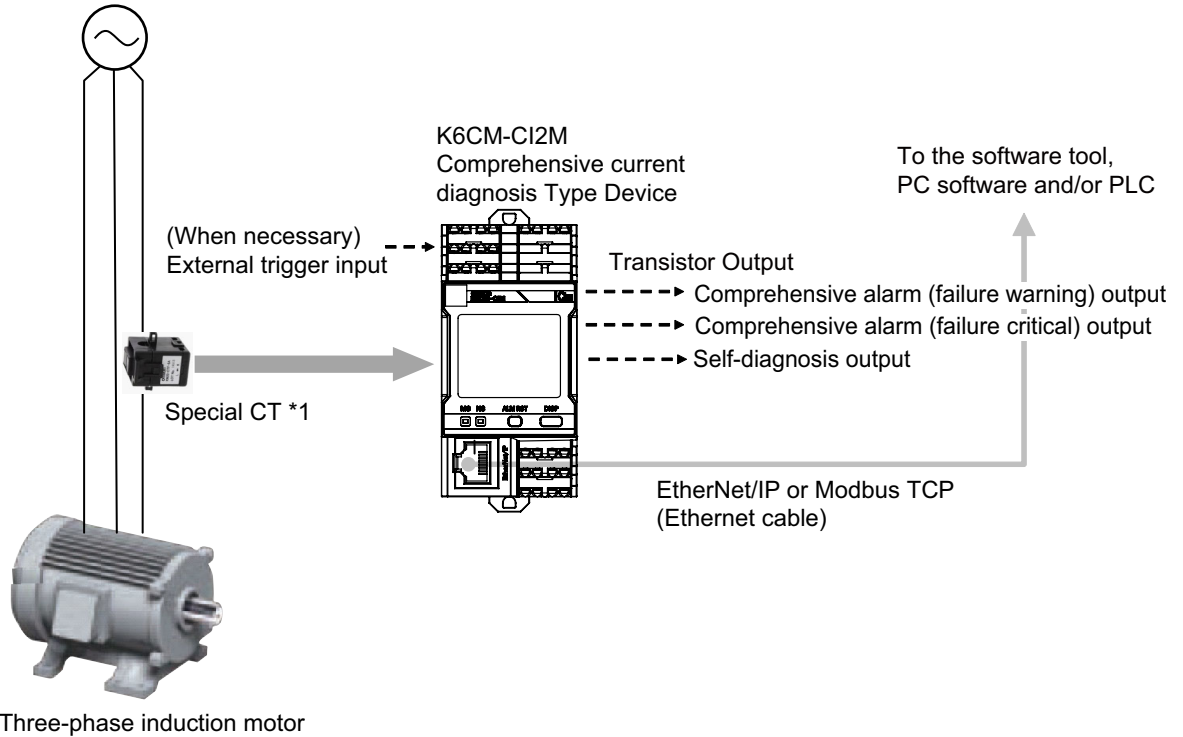

*1. The dedicated cable between the special CT and the K6CM device is 2.9 m long. It cannot be extended. Also, there is no designation in the phase to be installed. Be careful of the installation direction stated on the CT label and mount it to any one phase.

● Inverter driving three-phase induction motor connection example

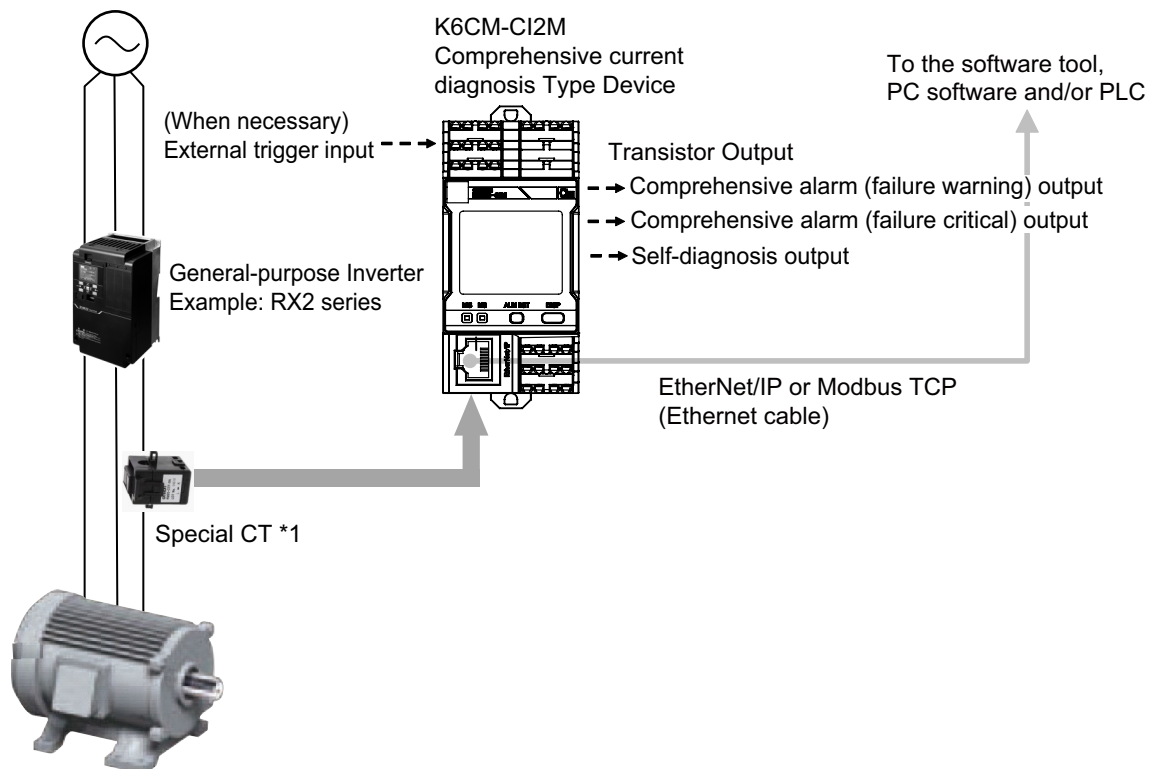

Inverter driving three-phase induction motor

- *1. The dedicated cable between the special CT and the K6CM device is 2.9 m long. It cannot be extended. Also, there is no designation in the phase to be installed. Be careful of the installation direction stated on the CT



Precautions for Correct Use

Using a K6CM-CIM

- When the motor is driven by an inverter, it may not be possible to monitor the motor or load abnormalities. Refer to 3-4-1 *Comprehensive Current Diagnosis Type (K6CM-CI2)* on page 3-19 in 3-4 *Guide for Setting Alarm* on page 3-19 for details.

Using a K6CM-CI2M

- In an environment where the motor is driven by an inverter, if the degradation level 1 is used as the measurement value, it may not be possible to monitor the motor or load abnormalities. Therefore, it is recommended to use the degradation level 2. Refer to 3-4-1 *Comprehensive Current Diagnosis Type (K6CM-CI2)* on page 3-19 in 3-4 *Guide for Setting Alarm* on page 3-19 for details.
- Since the frequency band of the harmonics of the drive frequency and the frequency band in which errors such as load imbalance and misalignment appear are the same frequency band for a 2-pole meter, sensitivity may be reduced with degradation level 2.

K6CM-VB Vibration & Temperature Type

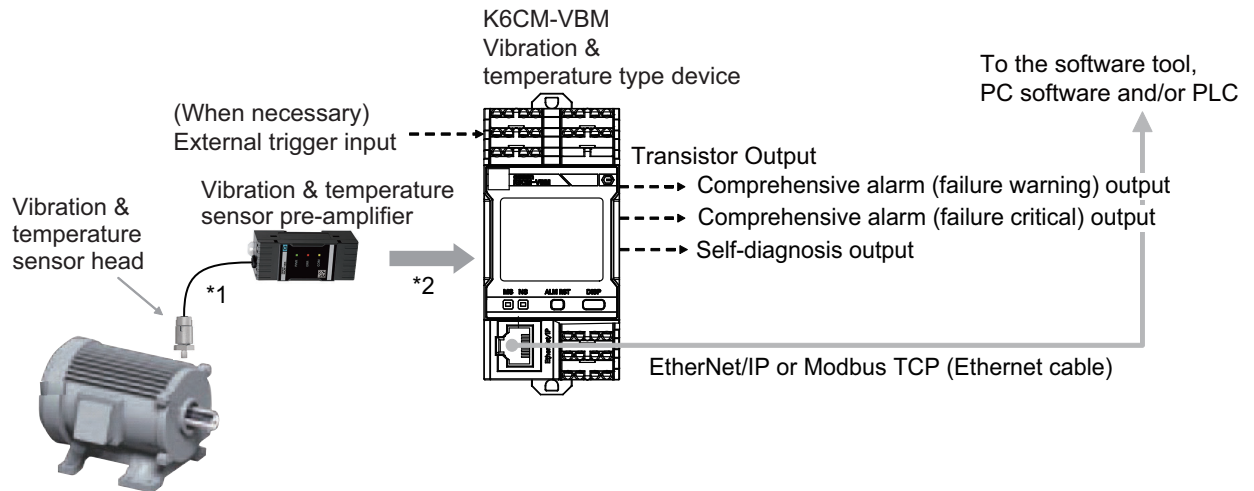

Three-phase induction motor

- *1. The dedicated cable between the sensor head and the pre-amplifier is 2.9 m long. It cannot be extended. The sensor head and the pre-amplifier are calibrated and inspected as a set at the factory shipment. Be sure to use them with the combination shipped. For details, refer to *Installation of the Vibration Sensor Head* on page 5-7.
- *2. The dedicated attached cable between the pre-amplifier and the K6CM device is 1 m. It can be extended up to a maximum length of 100 m. Refer to *A-5 Individual Specifications of the Dedicated Sensor* on page A-10 for recommended cables.

Note When you use an inverter to drive the motor, you may not be able to check the degradation tendency of the motor. However, under the following conditions, changes in acceleration are more likely to be confirmed.

- When the inverter driving frequency is 50 Hz or more and the frequency is stable
- When the carrier frequency of the inverter is 12.5 kHz or more and the frequency is stable

Use an inverter after trying according to your installation environment.

K6CM-IS Insulation Resistance Type

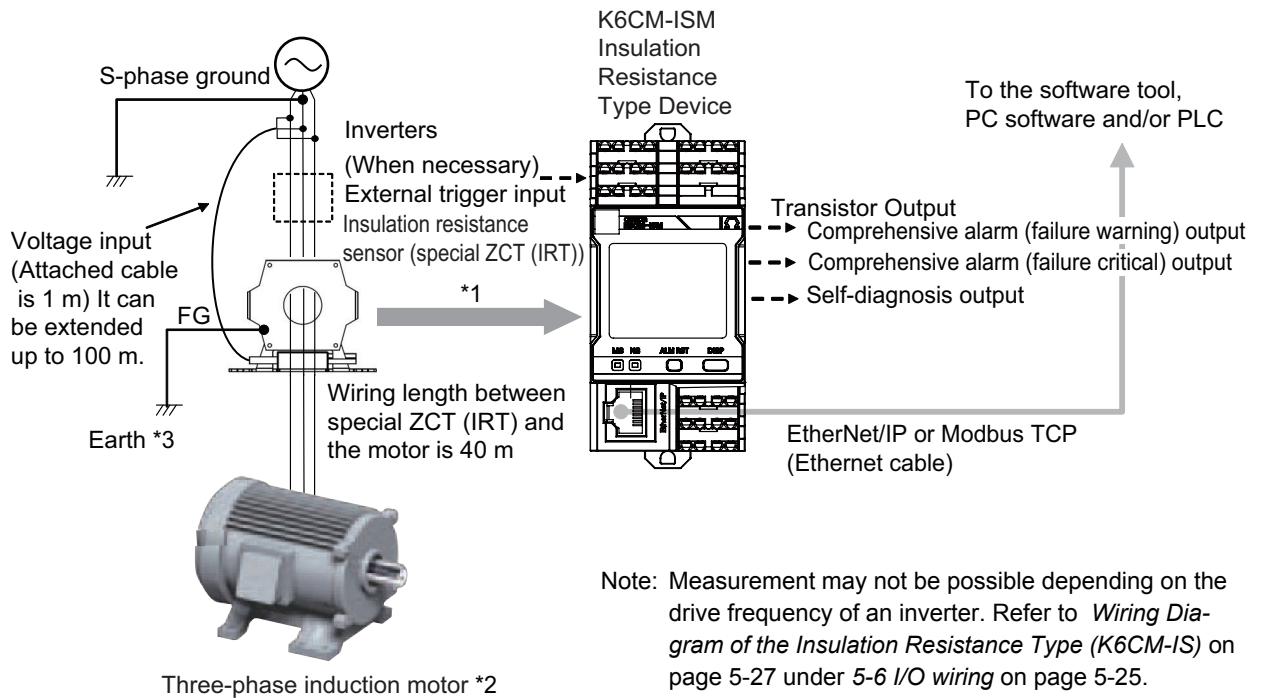

- *1. The distance between the insulation resistance sensor (special ZCT (IRT)) and K6CM device is 1 m with the dedicated attached cable.
- *2. Motor capacity of 7.5 kW or less (Measurement error will increase if exceeding this value.)
- *3. According to IEC 60364 TT method

1-5 Procedure

The K6CMs can be used in the following procedure.

Step	Procedures	Reference			
<p>1. Initial setting on desk</p>	<p>Prepare a PC with Windows 7 or higher and Ethernet cables. Install the software tool.</p>	<p>Section 4 Introduction of the Motor condition monitoring Tool</p>			
	<p style="text-align: center;">↓</p> <p style="text-align: center;">Start the software tool.</p>				
	<table border="1" style="width: 100%;"> <tr> <td style="width: 80%;">Connect the software tool directly to the K6CM device via Ethernet cable.</td> <td rowspan="2" style="width: 20%; text-align: center;">Either order is acceptable.</td> </tr> <tr> <td>Turn ON the power to the K6CM device.</td> </tr> </table>		Connect the software tool directly to the K6CM device via Ethernet cable.	Either order is acceptable.	Turn ON the power to the K6CM device.
	Connect the software tool directly to the K6CM device via Ethernet cable.		Either order is acceptable.		
Turn ON the power to the K6CM device.					
<p style="text-align: center;">↓</p> <p>Select [Create Project],</p> <ul style="list-style-type: none"> • Set the IP address of each K6CM device • Set default parameters • Set other parameters (when necessary) • Download IP address and (when necessary) parameters to K6CM device. • (When necessary) Set the motor name (K6CM group name) of each K6CM. 					
<p>2. Installation and Wiring</p>	<p style="text-align: center;">▼</p> <p style="text-align: center;">Install.</p>	<p>Section 2 Device Components</p> <p>Section 5 Installation and Wiring</p>			
	<p style="text-align: center;">↓</p> <p style="text-align: center;">Wire.</p>				
<p>3. Setting with actual system configuration (via hub)</p>	<p style="text-align: center;">▼</p> <p style="text-align: center;">Connect the software tool to the K6CM device (s) via hub.</p>	<p>Section 6 How to Use the Motor condition monitoring Tool</p>			
	<p style="text-align: center;">↓</p> <p style="text-align: center;">(When necessary) Change the parameters and download to each K6CM device.</p>				
	<p style="text-align: center;">↓</p> <p style="text-align: center;">Turn ON the power of the K6CM again and activate the parameters.</p>				
<p style="text-align: center;">▼</p>					

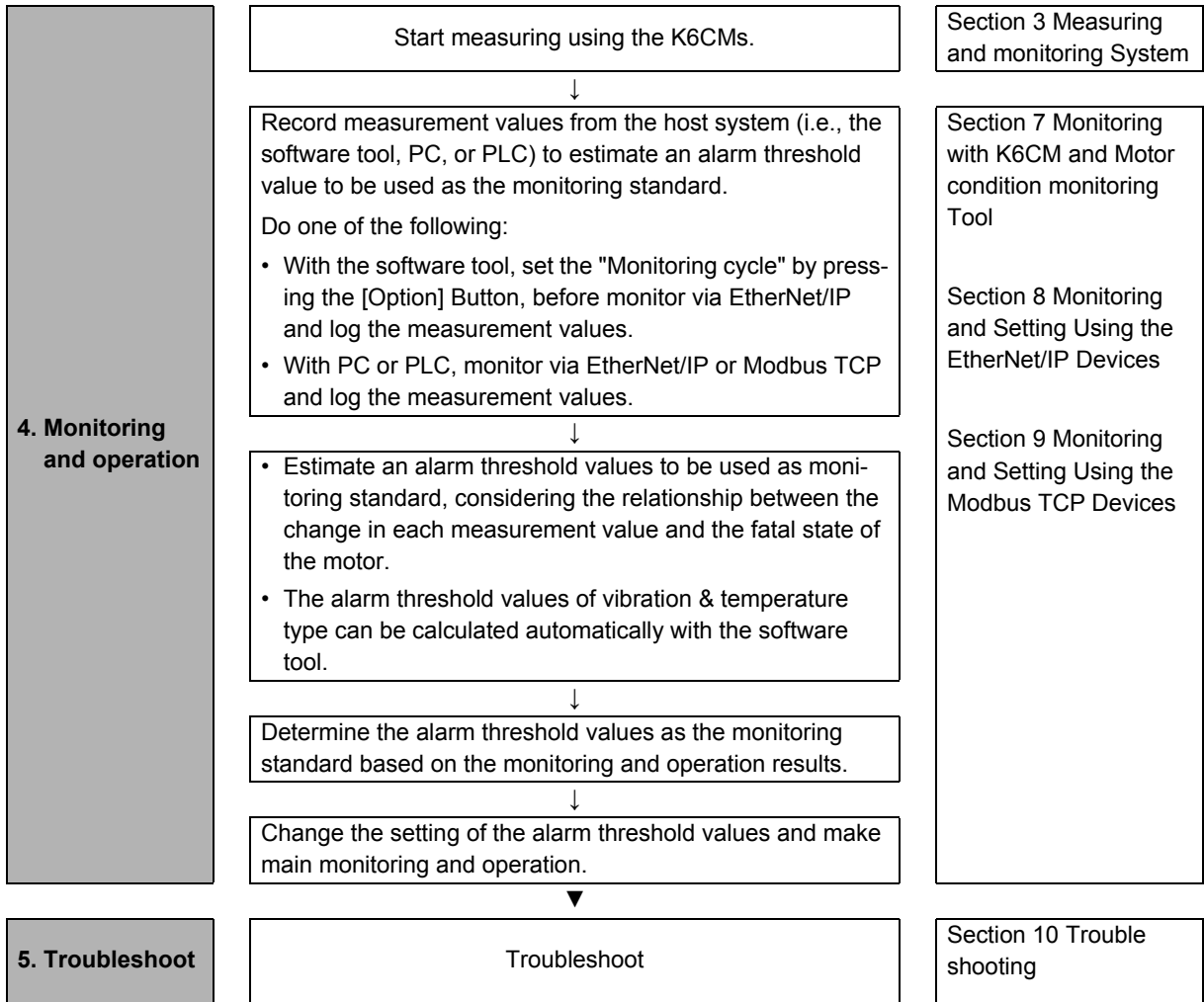

2

Device Components

This section describes the nomenclature and functions of the K6CM devices, the special CT, the vibration and temperature sensor, and the insulation resistance sensor.

2-1 Overview of K6CM Device	2-2
2-1-1 K6CM Device	2-2
2-1-2 Label of the K6CM Device	2-2
2-2 Nomenclature and Functions of the K6CM Device	2-3
2-2-1 K6CM Device	2-3
2-2-2 Transition of Numeric LCD Display	2-8
2-2-3 Status of Alarm Bar, Status Indication, and Transistor Output for Each Status	2-9
2-3 Special CT	2-10
2-4 Vibration & Temperature Sensor	2-11
2-5 Insulation Resistance Sensor (Special ZCT (IRT))	2-13

2-1 Overview of K6CM Device

The appearances of the K6CM device and the nomenclature and functions are as follows.

2-1-1 K6CM Device

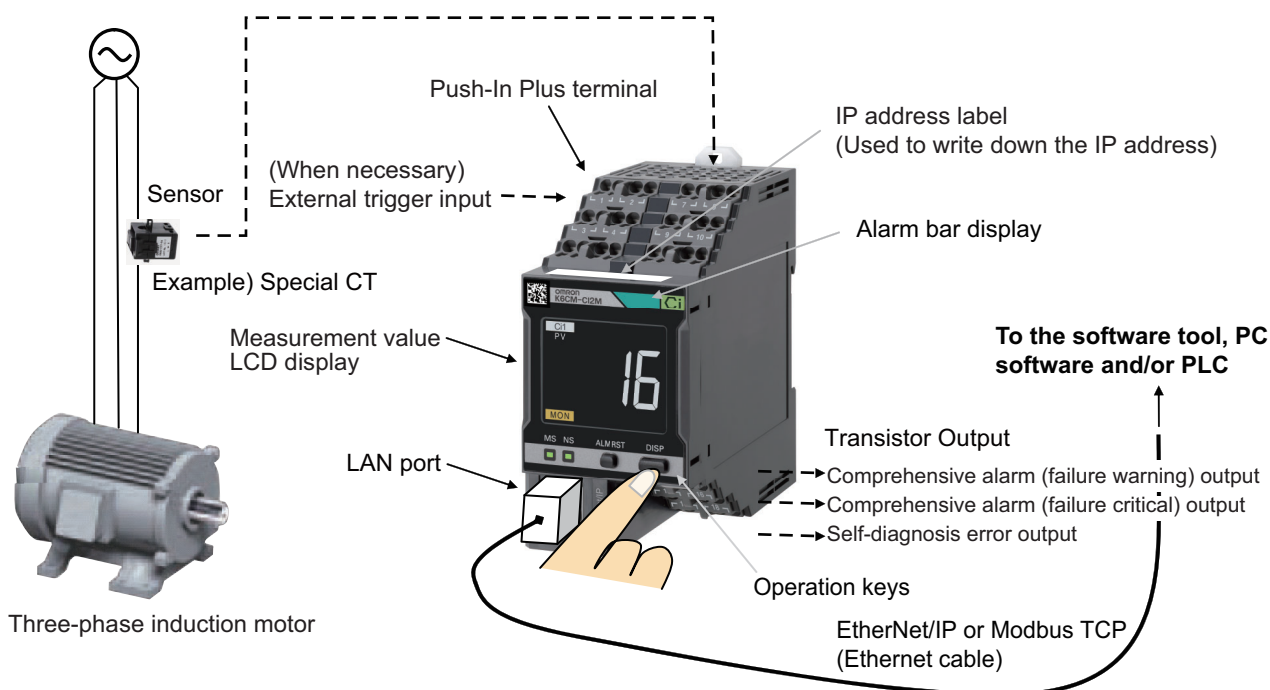

2-1-2 Label of the K6CM Device

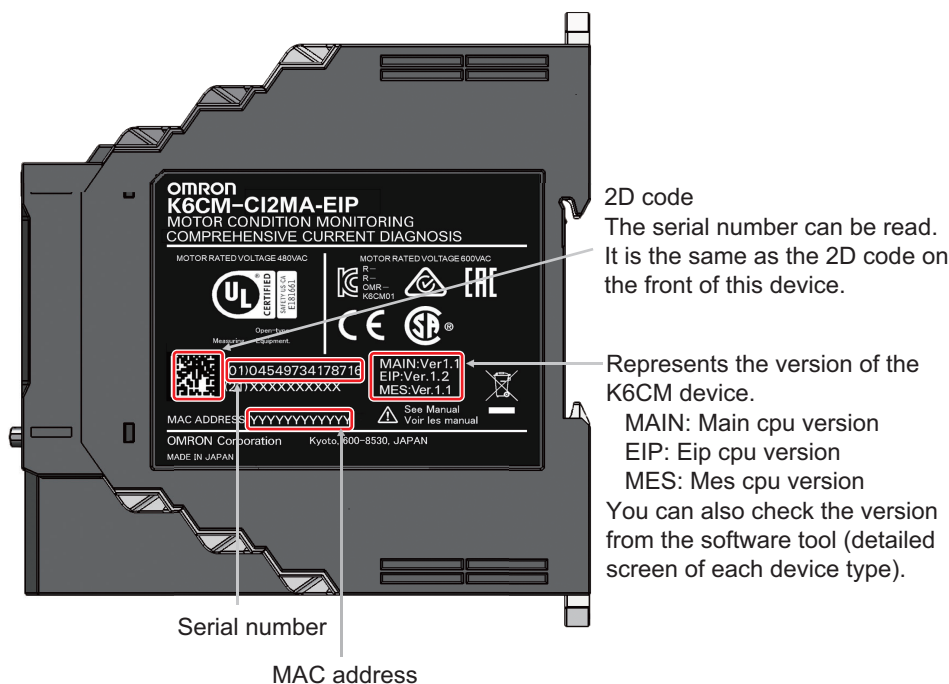

2-2 Nomenclature and Functions of the K6CM Device

2-2-1 K6CM Device

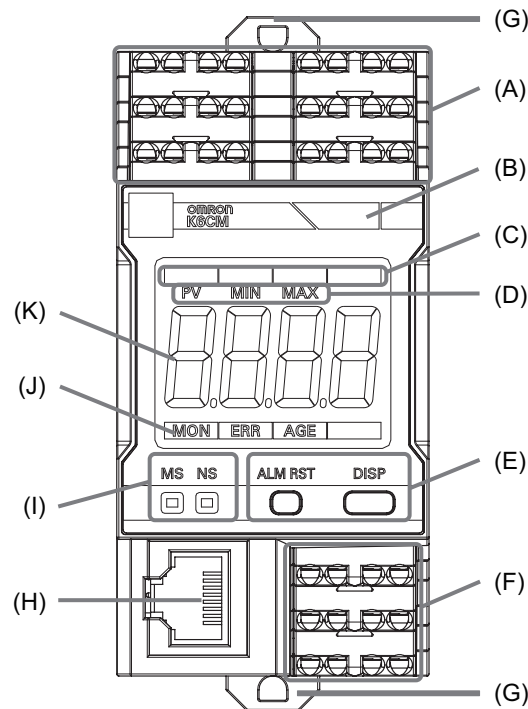

Symbol	Name	Function
(A)	Upper terminal	Connect Push-in Plus terminals. Refer to <i>Push-In Plus Terminals Layout</i> on page 2-5 later in this document for details.
(B)	Alarm bar display	During monitoring, the following colors are displayed.* ¹ <ul style="list-style-type: none"> • Green: Alarm status (normal) • Yellow: Alarm status (warning) • Red: Alarm status (critical) Turns OFF when one of the following occurs. When the power is OFF, when measuring is not started yet, when self-diagnosis error occurs
(C)	Unit of measurement value (monitoring type)	The unit of measurement value (monitoring type) is indicated by the LCD characters.* ²

Symbol	Name	Function	
(D)	Each type of current value, minimum value, maximum value of measurement value	<p>When the K6CM device is monitoring, a numerical value is displayed. An LCD character indicates whether the measurement value displayed on the LCD is the present value, minimum value, or maximum value.*³</p> <ul style="list-style-type: none"> • "PV": present value • "MIN": minimum value • "MAX": maximum value <p>The minimum and maximum values indicate the current minimum and maximum values in one monitoring period.</p> <p>The display is updated each time the minimum and maximum values are updated. Both are retained at the end of monitoring, but will be reset the next time the power is turned ON again.</p>	
(E)	Operation keys	[ALM RST] key	Release the alarm latch (cancellation by communication is impossible). ^{*4}
		[DISP] key	<p>Switch the unit of measurement value (monitoring type).</p> <p>"Display fixed mode"</p> <p>Press the [DISP] key to switch the display in the following order.</p> <ul style="list-style-type: none"> • Comprehensive current diagnosis type: "Ci1" → "Ci2" → "A" (→ "Ci1") • Vibration & temperature type: "G" → "mm/s" → "T" → "ΔT" (→ "G") • Insulation resistance type: "MΩ" → "mA" (→ "MΩ") <p>"Display auto switching mode"</p> <p>Press and hold the [DISP] key for 3 seconds to switch the display automatically at 5-second intervals in the following order.</p> <ul style="list-style-type: none"> • Comprehensive current diagnosis type: "Ci1" → "Ci2" → "A" (→ "Ci1") • Vibration & temperature type: "G" → "mm/s" → "T" → "ΔT" (→ "G") • Insulation resistance type: "MΩ" → "mA" (→ "MΩ")
		Simultaneously press the [ALM RST] key and the [DISP] key	When pressed at the same time for 5 seconds or more, initialize all settings of the K6CM device and restore the Factory default.
(F)	Lower terminal	<p>Connect Push-in Plus terminals.</p> <p>Refer to <i>Push-In Plus Terminals Layout</i> on page 2-5 later in this document for details.</p>	
(G)	DIN Track mounting hook	Used for mounting to the DIN Track.	
(H)	LAN port	<p>Port for connecting Ethernet cable for communications with the software tool, PLC, and PC.</p> <p>It is with straight/cross cable automatic discrimination function.</p>	
(I)	Indicators	<p>Indicates the product status or network status by LEDs.</p> <ul style="list-style-type: none"> • "MS": Module Status. Displays the status of the K6CM device. It is green when it is normal. • "NS": Network Status. Displays the state of the communications. It lights or flashes green when it is normal. <p>Refer to <i>Indicator specifications</i> on page 2-7 later in this document for details.</p>	
(J)	Status display	<p>K6CM device status is indicated one of monitoring in progress, self-diagnosis error, Running Time status^{*5}, with the LCD character below.</p> <ul style="list-style-type: none"> • "MON": Monitoring in progress^{*6} • "ERR": Self-diagnosis error occurrence • "AGE": Running Time notification (recommendation for exchange of product body) 	

Symbol	Name	Function
(K)	Numeric LCD display	<ul style="list-style-type: none"> When monitoring is started, the measurement value is displayed. Comprehensive current diagnosis type 2: Degradation level 1, degradation level 2, current Vibration & temperature type: Acceleration, velocity, motor temperature, difference between motor temperature and room temperature Insulation resistance type: Insulation resistance, leakage current Switching display of the monitor type can be performed by [DISP] key. Press the [DISP] key to switch the display in the following order. <ul style="list-style-type: none"> Comprehensive current diagnosis type: "Ci1" → "Ci2" → "A" (→ "Ci1") Vibration & temperature type: "G" → "mm/s" → "T" → "ΔT" (→ "G") Insulation resistance type: "MΩ" → "mA" (→ "MΩ") With trigger (external trigger or internal trigger), "- - -" is displayed if monitoring is not started yet. When the monitoring is completed, the measurement value just before the end is retained and displayed. For details, refer to <i>Transition of Numeric LCD Display</i> on page 2-8.

- *1. The above LCD color is retained after monitoring.
- *2. Switching display of present value (PV), minimum value, and maximum value can be set by changing "Display value type" from the software tool. (It is not switchable by front operation.)
- *3. When the vibration & temperature sensor or the insulation resistance sensor (special ZCT (IRT)) is not connected, "- - -" is displayed and the "MS" flashes.
When the input range is over, 7 segments will flash with the maximum value of the input range.
- *4. Setting the alarm latch to "L" will latch the alarm condition of comprehensive alarm (warning or critical) (alarm bar, transistor outputs 1 and 2). Release this latched state.
If you press the [ALM RST] key during monitoring, it returns to the comprehensive alarm state at that point (both the alarm bar and transistor outputs 1 and 2).
- *5. Running Time is a function to inform you when to replace the K6CM device. It is calculated from the internal temperature and the operation time of the device.
- *6. "MON" always lights up when the trigger mode is "Free run" (no trigger). When there is a trigger, it lights up during monitoring. It turns off after monitoring is not started yet, and after monitoring is completed (only when using the trigger function).

● Push-In Plus Terminals Layout

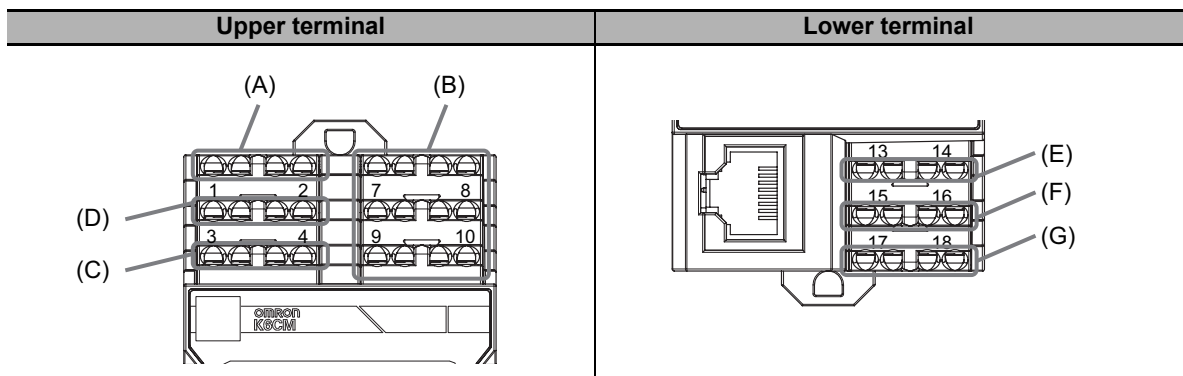

Symbol	Name	Function
(A)	Power voltage input	100 to 240 VAC 24 VAC/VDC
(B)	Sensor input	K6CM-CI2M: CT input (7: CTK, 8: CTL)
		K6CM-VB: VB input
		K6CM-IS: ZCT (IRT) input
(C)	Not used	---

Symbol	Name	Function
(D)	External trigger input	Trigger input by external input that sets the K6CM device status during monitoring (status display "MON"). Monitoring can be started during the rise from OFF → ON or the fall from ON → OFF, and monitoring up to the monitoring time, or monitoring in the ON state can be selected.*1
(E)	Transistor output 1	<p>Warning output of comprehensive alarm.*2</p> <p>Transistor output method can be set to Normally Close or Normally Open.*3</p> <ul style="list-style-type: none"> • Normally Close output type ON: Comprehensive alarm is normal OFF: Comprehensive alarm is warning or critical • Normally open output type ON: Comprehensive alarm is warning or critical OFF: Comprehensive alarm is normal <p>It turns OFF regardless of the output type in either of the following cases.</p> <ul style="list-style-type: none"> • Monitoring is not started yet (only when using the trigger function) • Self-diagnosis error
(F)	Transistor output 2	<p>Critical output of comprehensive alarm.*2</p> <p>Transistor output method can be set to Normally Close or Normally Open.</p> <ul style="list-style-type: none"> • Normally Close output type ON: Comprehensive alarm is normal or warning OFF: Comprehensive alarm is critical • Normally open output type ON: Comprehensive alarm is critical OFF: Comprehensive alarm is normal or warning <p>It turns OFF regardless of the output type in either of the following cases.</p> <ul style="list-style-type: none"> • Monitoring is not started yet (only when using the trigger function) • Self-diagnosis error
(G)	Transistor output 3	<p>Self-diagnosis error output.</p> <p>Transistor output method can be set to Normally Close only.</p> <p>* Self-diagnosis error is a function to detect errors of the K6CM device itself.</p> <p>In the following cases, ON</p> <ul style="list-style-type: none"> • When Self-diagnosis error does not occur <p>In the following cases, OFF</p> <ul style="list-style-type: none"> • Self-diagnosis error occurrence

*1. "MON" always lights up when the trigger mode is "Free run" (no trigger). When there is a trigger, it lights up during monitoring. It turns off if monitoring is not started yet and after monitoring is completed. (only when using the trigger function)

*2. The output state (ON/OFF) of the transistor is held at the end of monitoring. (only when using the trigger function)

*3. The setting function of transistor output method can be used with Eip cpu version 1.10 or later. It is fixed to Normally Close with Eip cpu version less than 1.10.

● Indicator specifications

Symbol	Name	Color	Status	Operating condition
MS	Module status indication (Module Status)	Green	Lit.	Normal status
			Flashes at 1-s intervals.	BOOTP server connection error state
		Red	Lit.	One of the following fatal errors <ul style="list-style-type: none"> • Mes cpu data flash error • Main cpu data flash error
			Flashes at 1-s intervals.	One of the following conditions <ul style="list-style-type: none"> • Vibration & temperature sensor is not connected • Insulation resistance sensor (ZCT (IRT)) is not connected • Mes cpu error • Main cpu error • Present value input error • MAX value input error • MIN value input error
		---	Not lit.	No power supply
NS	Network status indication (Network Status)	Green	Lit.	Tag data link or message connection established
			Flashes at 1-s intervals.	No tag data link or message connection established
		Red	Lit.	IP address duplication status
			Flashes at 1-s intervals.	The connection has timed out
		---	Not lit.	No power supply or IP address is not set

2-2-2 Transition of Numeric LCD Display

The numerical LCD display will transition as follows after turning ON the power supply or after software reset *1.

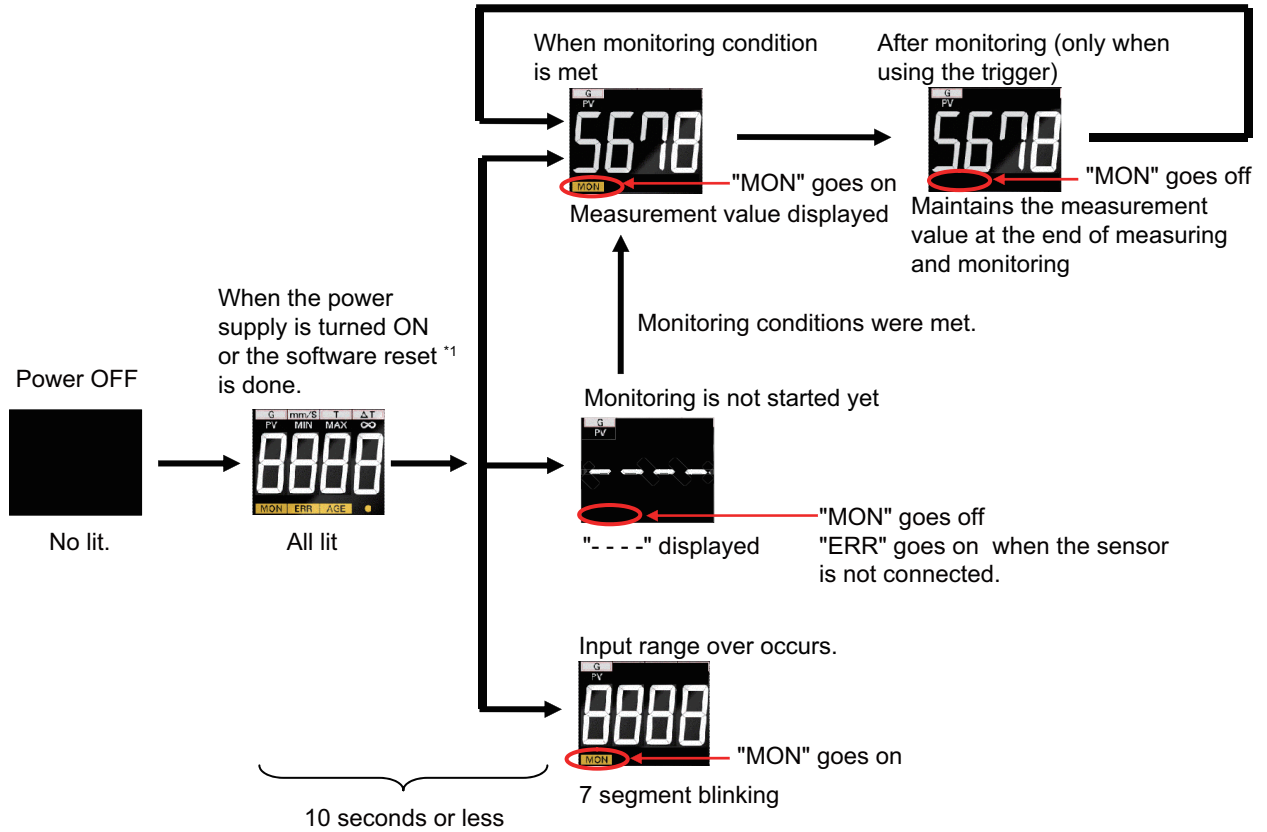

*1. It depends on the Device reset button operation from the software tool or software reset command from EtherNet/IP.

2-2-3 Status of Alarm Bar, Status Indication, and Transistor Output for Each Status

Status	Description	Alarm bar	Status display	Transistor output 1	Transistor output 2	Transistor output 3
Monitoring Not yet	Monitoring is not completed until the measurement value is set after the power is turned ON.	Not lit.	Not lit.	OFF	OFF	ON
During monitoring	Comprehensive alarm: normal	Green	"MON"	ON*1	ON*1	ON
	Comprehensive alarm: Warning	Yellow		OFF*1	ON*1	ON
	Comprehensive alarm: Critical	Red		OFF*1	OFF*1	ON
After monitoring (only when using the trigger function)	When using the trigger function (external trigger or internal trigger), the monitoring is completed.	The status at the end is kept.	Not lit.	The status at the end is kept.	The status at the end is kept.	ON
When the self-diagnosis error occurs	Self-diagnosis error is occurring regardless of monitoring status.	Not lit.	"ERR"	OFF	OFF	OFF
When the power is OFF	----	Not lit.	Not lit.	OFF	OFF	OFF

*1. This is the case when the transistor output type is set to Normally Close. In the case of Normally Open, ON/OFF is opposite to the above.

2-3 Special CT

The appearance of the special CT and the name and functions of each part are as follows.

Nomenclature and functions of the special CT

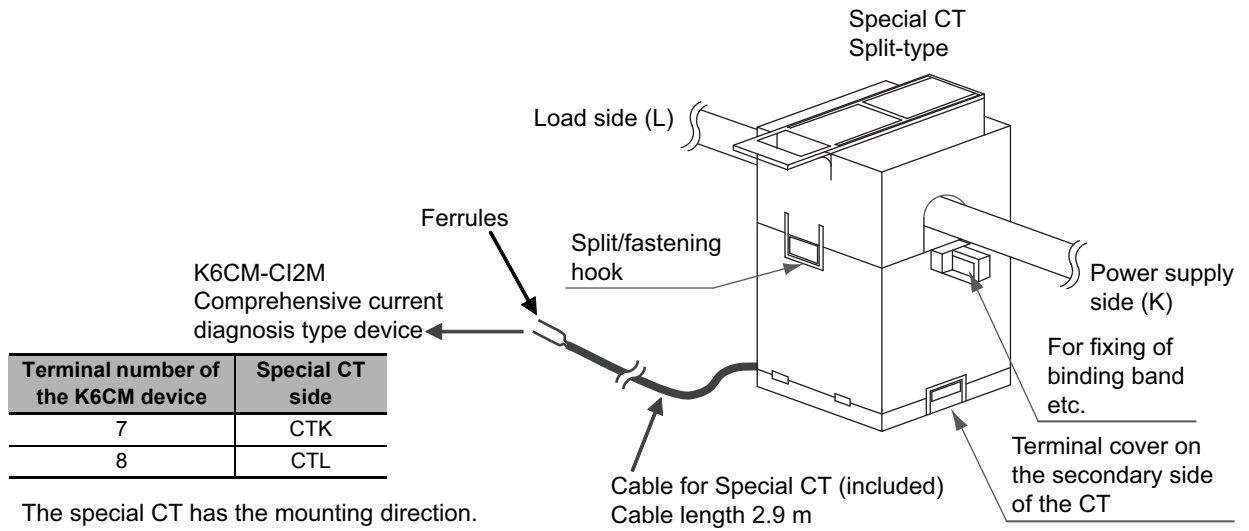

2-4 Vibration & Temperature Sensor

The appearance of the vibration and temperature sensor and the name and functions of each part are as follows.

Overview

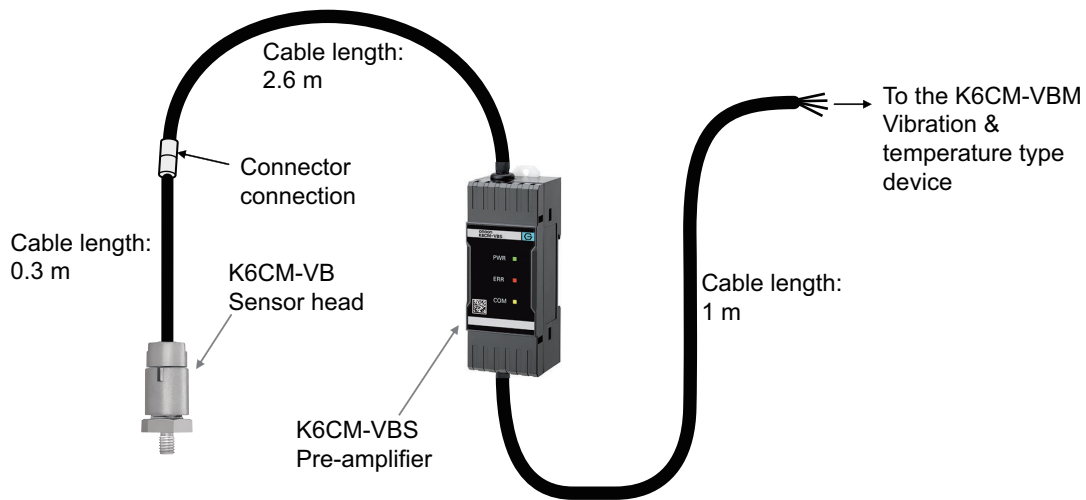

Nomenclature and functions of the pre-amplifier



LED	Name	Color	Status	Operating condition
PWR	Pre-amplifier power supply	Green	Lit.	Normal status
		----	Not lit.	Power not supplied
ERR	Pre-amplifier fault	Red	Lit.	Self-diagnosis error occurred
COM	Communications between pre-amplifier and K6CM	Yellow	Lit.	STX transmission, lit at reception 50 ms

Terminal number of the K6CM device	Vibration & temperature sensor side	Line color
7	VBS 0: Sensor input (+)	Red and white
8	VBS 1: Sensor input (-)	Red
9	VBS 2: Supply to sensor 10 V (+)	Black
10	VBS 3: Supply to sensor 10 V (-)	Black and white

Nomenclature and functions of the sensor head

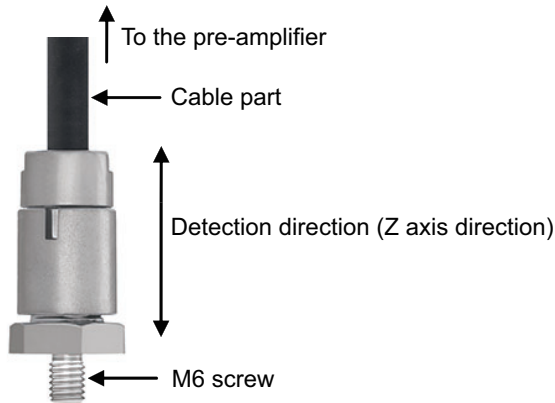

Mount the vibration sensor head on the shaft side exterior of the induction motor.

There are two ways to mount the vibration sensor head to the motor.

Method	Description
Method 1: Screw Mounting (recommended)	At the top of the armor of the motor, cut the tap into which the M6 screw vertically enters, and screw the vibration sensor head into it.
Method 2: Adhesive Mounting (*1)	Secure the attachment which is sold separately to the exterior of the motor using adhesive. Screw the vibration sensor head into the fixed attachment.

*1. K6CM will not conform to safety standards if attaching the vibration sensor with adhesive. In the case of disconnection, take safety measures such as fixing the cables.

We recommend method 1 with high absolute accuracy, but if you cannot tap off the motor, use method 2.

An easy-mounting magnet (called "Sensor Easy mounting magnet") is included. It can be used to determine the position to be measured. Note that measurement accuracy is not guaranteed in the case of magnet mounting.

The shapes of the easy-mounting magnet and the adhesive attachment are as follows.

These two shapes are similar. Be careful not to handle them by mistake.

Sensor Easy mounting magnet

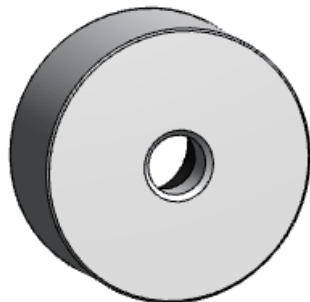

Adhesive attachment

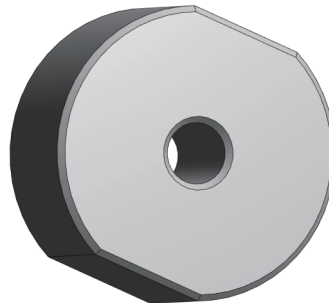

2-5 Insulation Resistance Sensor (Special ZCT (IRT))

The appearance of the insulation resistance sensor (special ZCT (IRT))^(*) and the name and functions of each part are as follows.

*1. ZCT (IRT) stands for Zero Current Transformer (Insulation Resistance Transformer).

Nomenclature and functions of the Insulation resistance sensor (special ZCT (IRT))

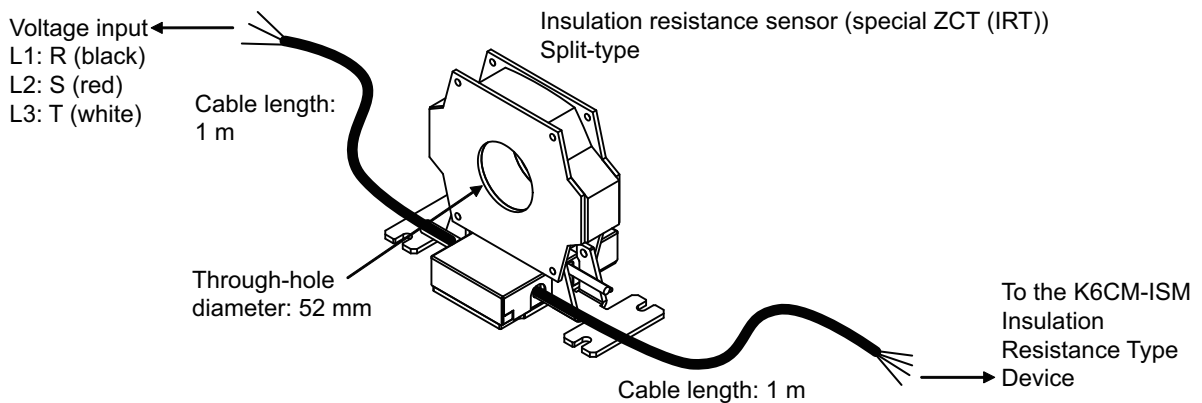

Terminal number of the K6CM device	Insulation resistance sensor (ZCT (IRT)) side	Line color
7	IRT0: Sensor input (+)	Red and white
8	IRT1: Sensor input (-)	Red
9	IRT2: Supply to sensor 10 V (+)	Black
10	IRT3: Supply to sensor 10 V (-)	Black and white

3

Measuring and monitoring System

This section describes the measuring and monitoring system and other features of the K6CM devices.

3-1	Internal mechanism of K6CM	3-2
3-1-1	Measuring and monitoring by K6CM	3-2
3-2	Measurement System	3-3
3-2-1	Sampling of measurement values	3-3
3-2-2	Moving average	3-4
3-2-3	Monitoring Delay	3-4
3-2-4	Trigger Mode	3-5
3-2-5	Maximum Value and Minimum Value of Measurement value	3-11
3-3	Monitoring System	3-13
3-3-1	Types of Individual Alarms	3-13
3-3-2	What is Comprehensive Alarm?	3-13
3-3-3	Relationship Between Alarm and Display/Output	3-14
3-4	Guide for Setting Alarm	3-19
3-4-1	Comprehensive Current Diagnosis Type (K6CM-CI2)	3-19
3-4-2	Vibration & Temperature Type (K6CM-VB)	3-23
3-5	How the Self-Diagnosis Function Works	3-25
3-6	How the Replacement Timing Notification (i.e., Running Time Function) Works	3-27
3-7	Initialization of Setting Value	3-28

3-1 Internal mechanism of K6CM

3-1-1 Measuring and monitoring by K6CM

What is Measuring?

After the power is turned ON, K6CM calculates measurement values every sampling period based on the input from the sensor.

The calculation of the measurement value is executed inside the K6CM even before the trigger start, and the measurement display is updated when the trigger is established.

This is called measuring.

What is Monitoring?

According to the trigger setting, K6CM performs threshold value judgment of the Warning/Critical level for a measurement value, and then determines whether the measurement value is within the Warning/Critical level as an "individual alarm". Next, the OR logic is obtained for each "individual alarm" and Normal/Warning/Critical is judged for each monitor target as the "Comprehensive alarm".

This is called monitoring. It displays the front LCD alarm bar of the K6CM device and performs transistor output.

As shown in the figure, it is as follows.

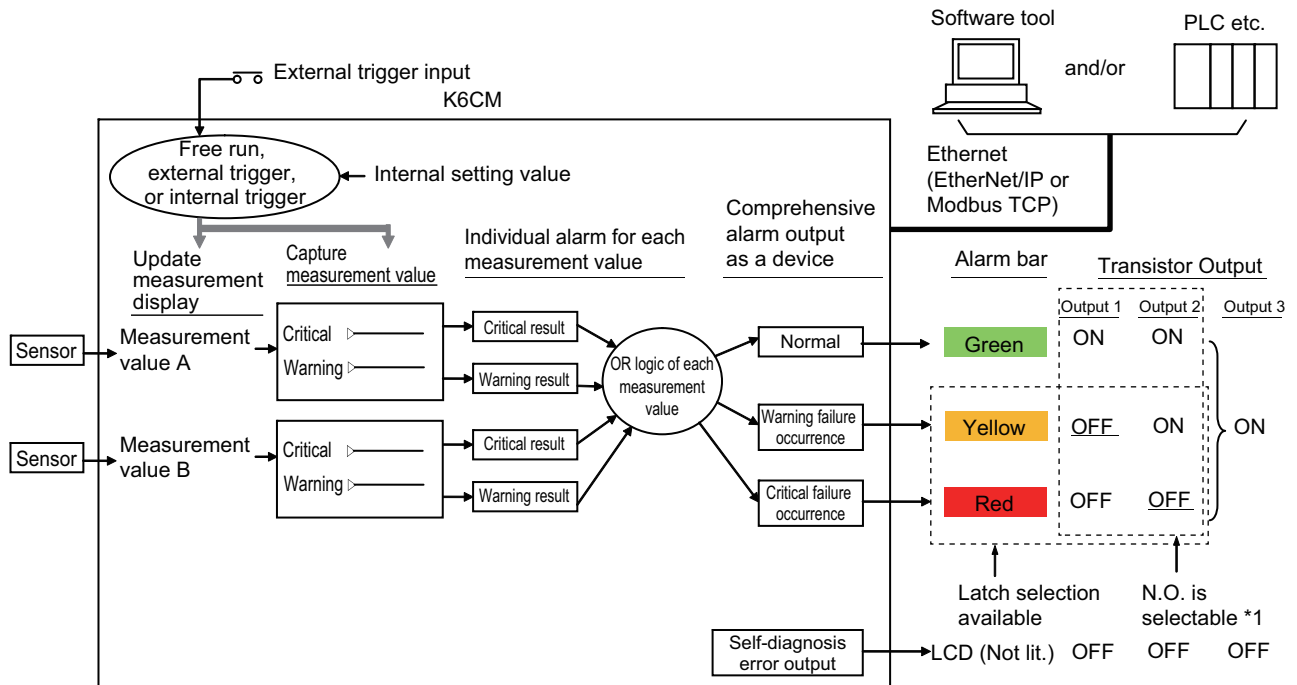

*1. It can be set to Normally open for Eip cpu version 1.10 or later of the K6CM device and the software tool version 1.1.0 or higher.

3-2 Measurement System

3-2-1 Sampling of measurement values

The input from the sensor is given to the K6CM device as a measurement value in every sampling period. The sampling period depends on the measured target as follows.

Monitor type	Measured target	Sampling period
Comprehensive current diagnosis type	Degradation level 1	5 s
	Degradation level 2	5 s
	Current	5 s
Vibration & temperature type	Acceleration	50 ms
	Velocity	0.5 s
	Temperature	0.5 s
Insulation resistance type	Insulation resistance	10 s (Normal mode)
		60 s (Inverter special measurement mode)

Also, until the next sampling is completed, the present measurement value is held as the PV. When the power is turned OFF, the held measurement value is reset.

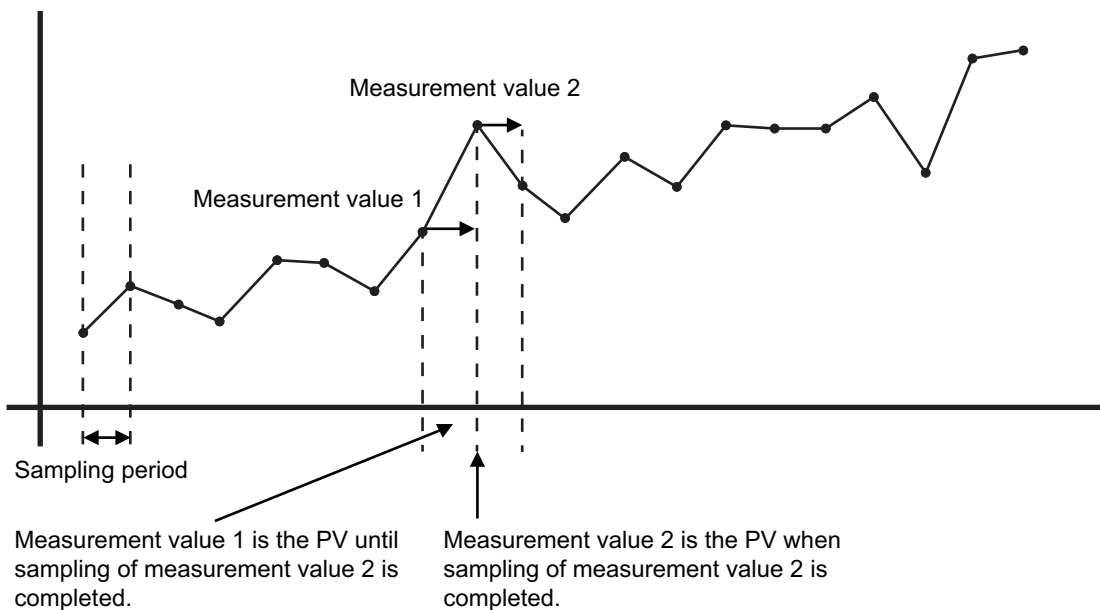

Note The sampling of the measurement value is performed internally even in the case of the unmeasured state before the trigger start.

3-2-2 Moving average

The moving average is the process of assuming the average value of past n times of measurement value which includes the measurement value of that time to be a current measurement value each time the sampling of the measurement value is performed. The moving average makes it possible to suppress the instantaneous fluctuation of the measurement value and make the tendency of the measurement value easier to see. The image of moving average is shown below.

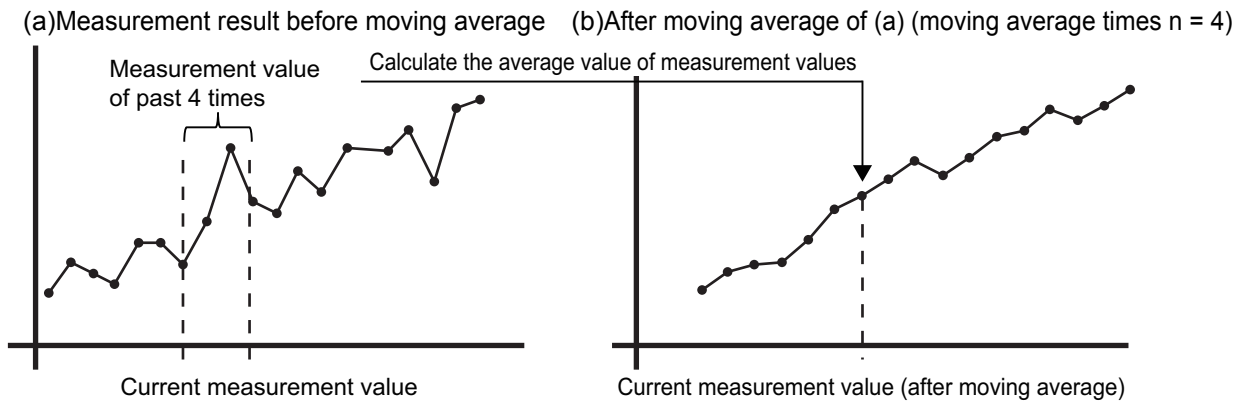

Note The sampling of the measurement value is performed internally even in the case of the unmeasured state before the trigger start.

3-2-3 Monitoring Delay

The monitoring delay is a function to delay the start of monitoring, and is used to wait for the measurement values to stabilize. The monitoring delay operates when the trigger mode is the external trigger or the internal trigger, and monitoring starts once the monitoring delay time has elapsed after the trigger start.

● Monitoring delay time settings

Trigger mode	Trigger type	Monitoring delay time
Free run	Disable	Disable
External trigger	Rising	Disable: 0.0 seconds Enable: 0.1 to 600.0 seconds
	Falling	
	Level	
Internal trigger	Rising	Disable: 0.0 seconds Enable: 0.1 to 600.0 seconds
	Falling	
	Level	

3-2-4 Trigger Mode

Trigger is a function of updating and monitoring the measurement values when certain conditions are met. To observe the aging of the motor, it is necessary to set the installation state, load, and rotation speed of the motor during measurement to the same condition, and to measure the motor rotating at a constant speed avoiding the state where the motor is stopped or accelerating or decelerating. Depending on the application, select the trigger mode from Free run (while power is ON), External Trigger, or Internal Trigger. The operation of each trigger mode is shown in the table below.

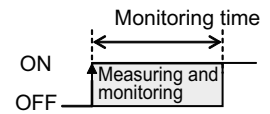
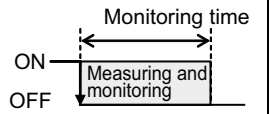
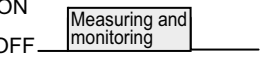
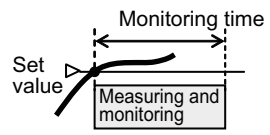
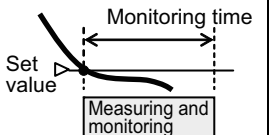
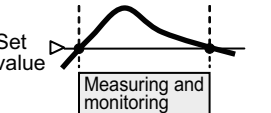
Trigger mode	Start condition of measuring and monitoring	Trigger type		
		Rising edge	Falling edge	Level
Free run (while power is ON)	All times after turning ON the power of the K6CM device	Always measuring		
External trigger	Depends on external conditions			
	• Start condition	When the external trigger input changes from OFF to ON	When the external trigger input changes from ON to OFF	While the external input is in the ON state
	• End condition	After the monitoring time has elapsed	After the monitoring time has elapsed	
Internal trigger^{*1}	Depends on the relationship between the measurement value and the set value (trigger level)			
	• Start condition	When the measurement value exceeds the set value (trigger level)	When the measurement value falls below the set value (trigger level)	While the measurement value exceeds the set value (trigger level)
	• End condition	After the monitoring time has elapsed	After the monitoring time has elapsed	Note : For the insulation resistance, this is while present value falls below the set value.

*1. The measurement values which can be set the trigger level are as follows.

- Comprehensive current diagnosis type: Current
- Vibration & temperature type: Acceleration
- Insulation resistance type: Insulation resistance

When you select the trigger mode from External trigger or Internal trigger, set the measurement start condition and end condition by selecting the trigger type.

Detailed information on trigger mode and behavior by status

The operation of the K6CM device and operation results from the software tool or message communications for each trigger mode and state are as follows.

Trigger mode	Status	K6CM device Operation			
		Measuring and monitoring status ^{*1}	Front Numeric LCD Display	Status display	Value read by software tool or message communications
Free run	Measuring and monitoring Not yet (immediately after turning ON the power)	No measuring and monitoring	"- - - -" is displayed	Not lit.	The read value is 0
	While the power is ON	Measuring and monitoring	Display measurement value (*2)	"MON"	The present value, the minimum value, and the maximum value of the measurement value can be read out individually
External trigger Or Internal trigger	Measuring and monitoring Not yet	No measuring and monitoring	"- - - -" is displayed	Not lit.	The read value is 0
	During measuring and monitoring	Measuring and monitoring	Display measurement value (*2)	"MON"	The present value, the minimum value, and the maximum value of the measurement value can be read out individually
	After measuring and monitoring	No measuring and monitoring	Holding and displaying values at the end of monitoring	Not lit.	The held values are read out at the end of the measuring and monitoring

*1. The monitoring status can be confirmed in "Main body status" from message communications.

*2. The front LCD number can display either the present value, the minimum value, or the maximum value depending on the setting.

● Example of Operation When the Trigger Mode Is "Free run"

- Measuring and Monitoring Not yet

The following is an example of the operation from the time the power is turned ON until the measurement value is calculated. In any case, Free run (no trigger) and external trigger and internal trigger, the same operation occurs.

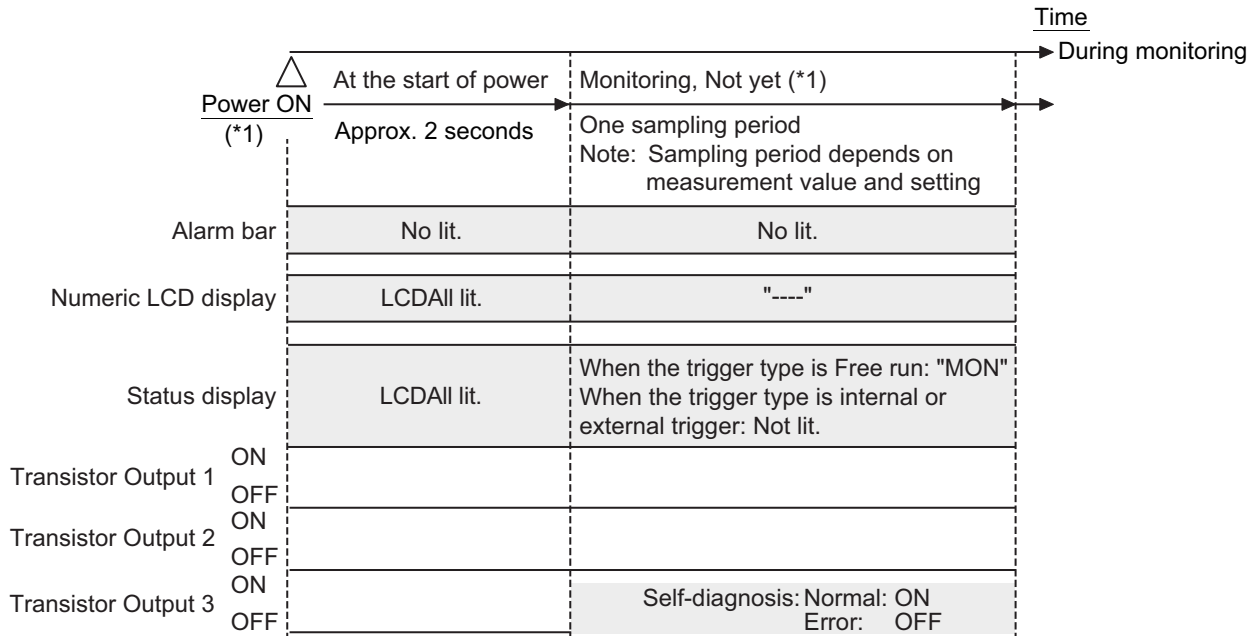

*1. PV of the measurement status is unmeasured status.

*2. Even if setting the transistor output method of outputs 1 and 2 to "Normally Open" or "Normally Close", the above operation will be performed from immediately after turning ON the power supply until measurement starts. The operation according to the setting is started at the start of measurement.

- During Measuring and Monitoring

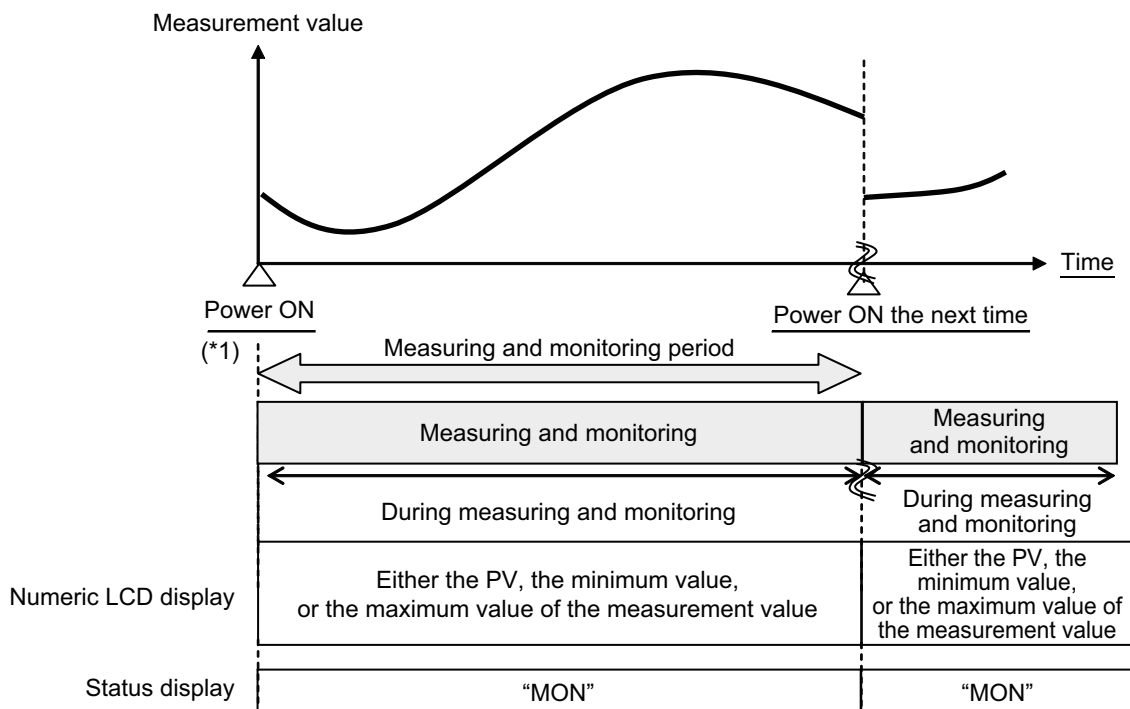

*1. In the above figure, the power-ON state and the unmeasured state (i.e., the state until the measurement value is calculated) that exist immediately after turning ON the power as shown below are omitted.

● **Example of Operation When the Trigger Mode Is "External trigger" or "Internal trigger"**

- Measuring and Monitoring Not yet

The operation is the same as the operation example when the trigger mode is "Free run".

Refer to P. 3-7.

During and After Measuring and Monitoring

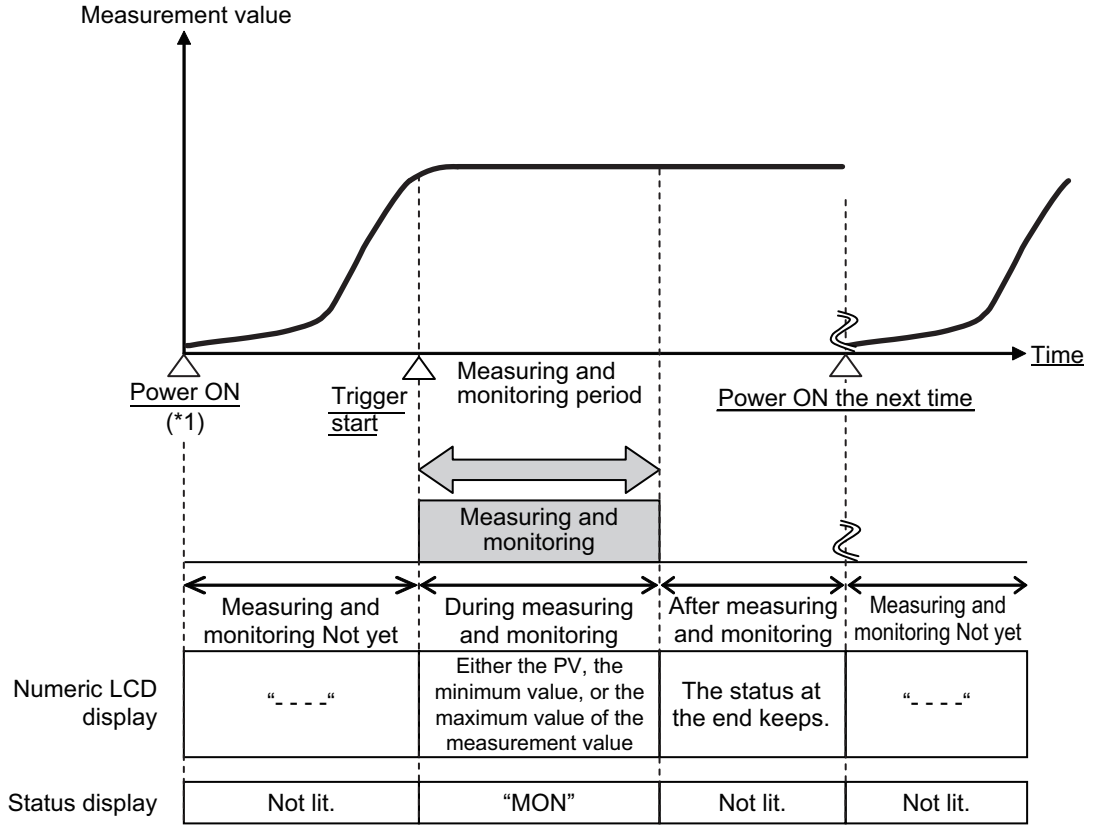

*1. In the above figure, the power-ON state and the unmeasured state (i.e., the state until the measurement value is calculated) that exist immediately after turning ON the power as shown on page 3-7 are omitted.

Monitoring Delay Settings

To observe the aging of the motor, it is necessary to set the condition of the motor at measurement to the same condition, and to measure the motor in a stable state avoiding the state where the motor is stopped or accelerating or decelerating. Start measurement at the appropriate timing by setting the monitoring delay time in reference to the following.

1 Determination of trigger mode

Refer to 3-2-4 *Trigger Mode* on page 3-5 and decide the trigger mode and trigger type according to the application.

2 Determination of moving average times

Reducing the moving average times can help capture instantaneous fluctuations.

Increasing the moving average times can suppress the steep fluctuation of measurement values and capture the overall trend.

Determine the moving average times of measurement values according to the state of measurement value.

3 Determination of monitoring delay time (when trigger mode is external trigger or internal trigger)

To obtain the measurement value when the state of the motor is stable, set the monitoring delay time using the following calculation formula.

Time to wait for motor to stabilize^{*1} × sampling period^{*2} × (moving average times^{*3} + 1)

*1 Time until the rotation speed stabilizes after the motor rotation speed is increased or decreased (during startup or changing of rotation speed).

*2 The sampling period differs for each measured target. For details, refer to 3-2-1 *Sampling of measurement values* on page 3-3.

*3 Set this as 1 when the moving average times setting is OFF.

The following is an example of when moving average times = 2.

● Example of moving average times = 2

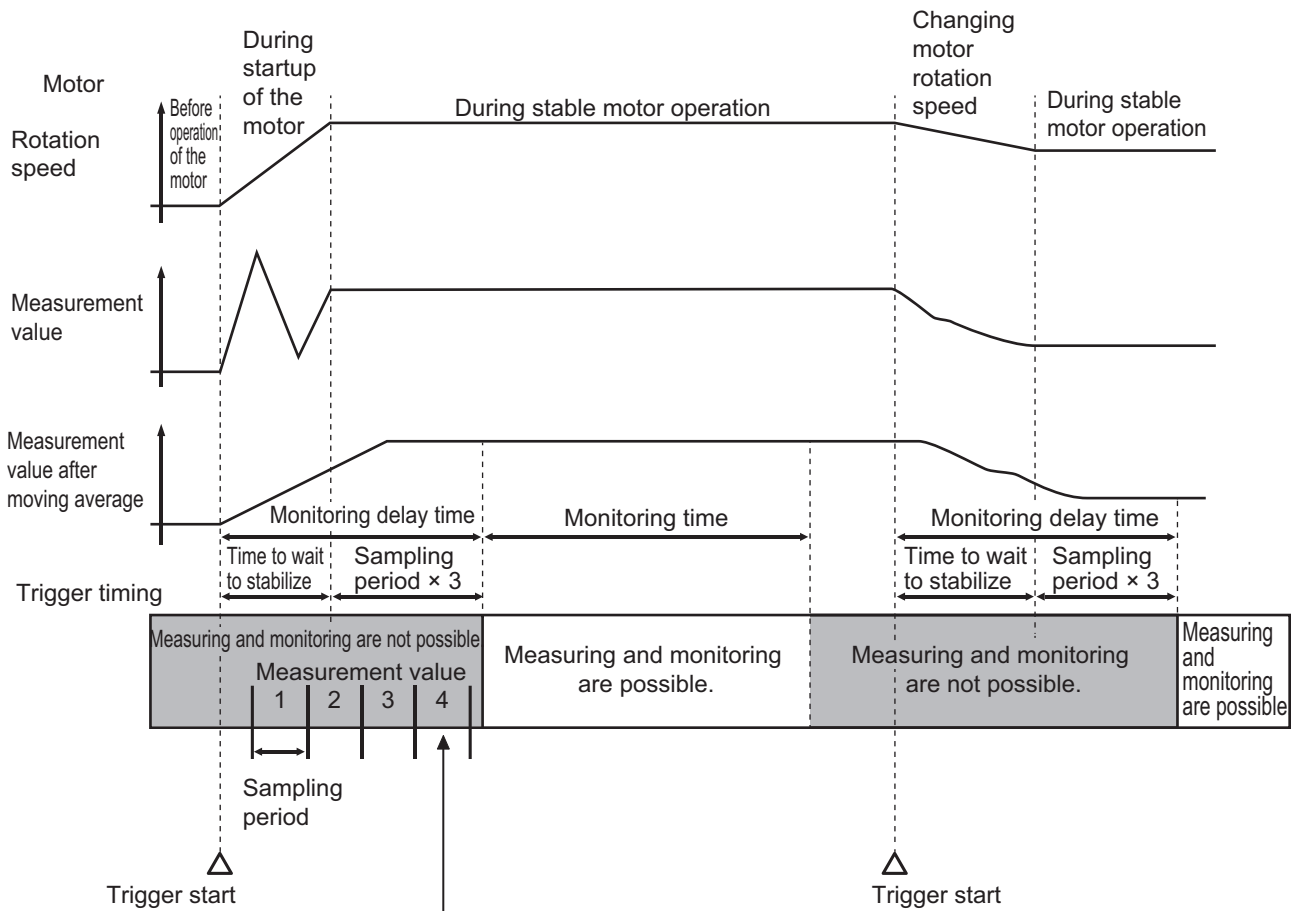

If monitoring are started during the calculation of "Measurement value 4", "Measurement value 2" measured during the wait to stabilize will be included because the moving average times will be twice. To exclude this measurement value, time to wait to stabilize + sampling period x 3 needs to be considered for the monitoring delay time.

In the example in the figure above, when the time to wait for motor to stabilize is 10 seconds and the measurement value is the velocity of vibration & temperature type (sampling period: 0.5 seconds), the value for the monitoring delay time will be the following value.

Monitoring delay time
 = time to wait for motor to stabilize + sampling period × (moving average times + 1)
 = 10 s + 0.5 s × (2+1)
 = 11.5 s

Also, determine a monitoring time that will fit within the motor stable operation.

3-2-5 Maximum Value and Minimum Value of Measurement value

The K6CM retains the Max./min. measurement value during measuring and monitoring period as internal data. They can be read by the software tool or by message communications.

With this function, by reading the maximum or minimum value of the measurement value for a certain period and comparing it with another period, it is possible to detect signs of Criticality of the motor.

Also, changing the setting allows you to set the display value of the front LCD of the K6CM device to the maximum value or the minimum value.

The software tool or message communications can be used to reset the retained Max./min. values after monitoring by operating the "Max./min. reset" setting.

The measuring and monitoring period depends on the trigger mode. The maximum value and the minimum value also operate according to each trigger mode as follows.

Trigger mode	Status	Max./min. measurement values	When resetting the maximum and minimum values with the software tool or the message communications
Free run	While the power is ON	Update the Max./min. values of each measurement value after power-on.	The PV at that time is updated and then will be updated.
External trigger Or Internal trigger	Measuring and monitoring Not yet	"- - -" is displayed and 0 is retained.	
	During measuring and monitoring	Update the Max./min. values of each measurement value from the measuring and monitoring start.	The PV at that time is updated and then will be updated.
	After measuring and monitoring	Max./min. values are retained.	Reset to 0.

● Example of Operation When the Trigger Mode Is "Free run"

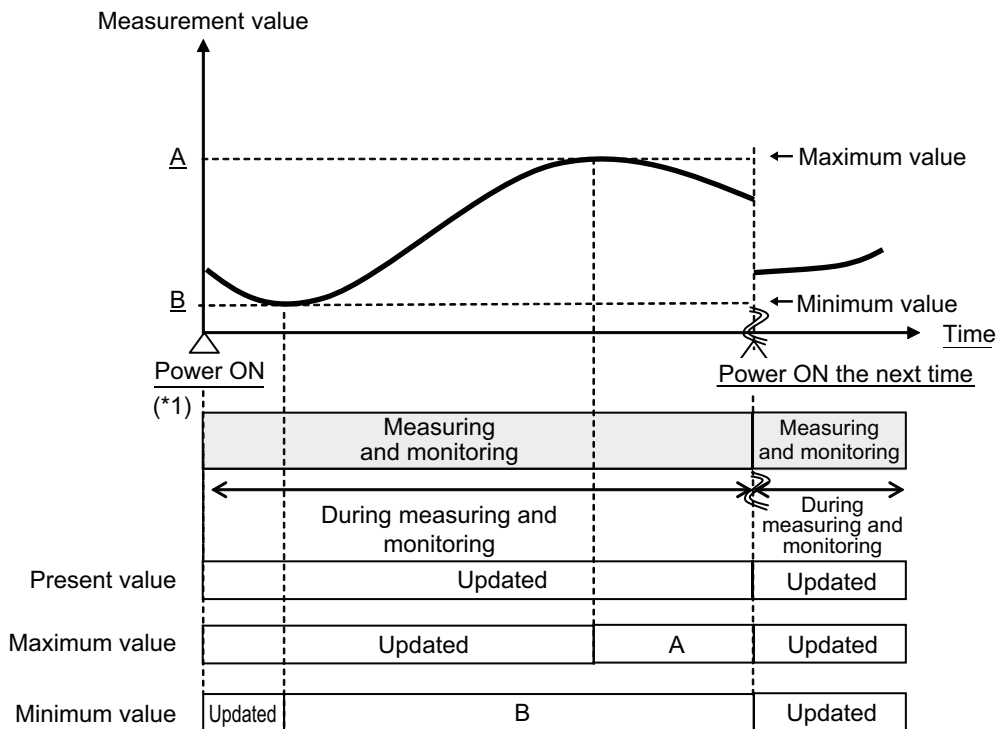

*1. In the above figure, the power-ON state and the unmeasured state (i.e., the state until the measurement value is calculated) that exist immediately after turning ON the power as shown on page 3-7 are omitted.

● Example of Operation When the Trigger Mode Is "External trigger" or "Internal trigger"

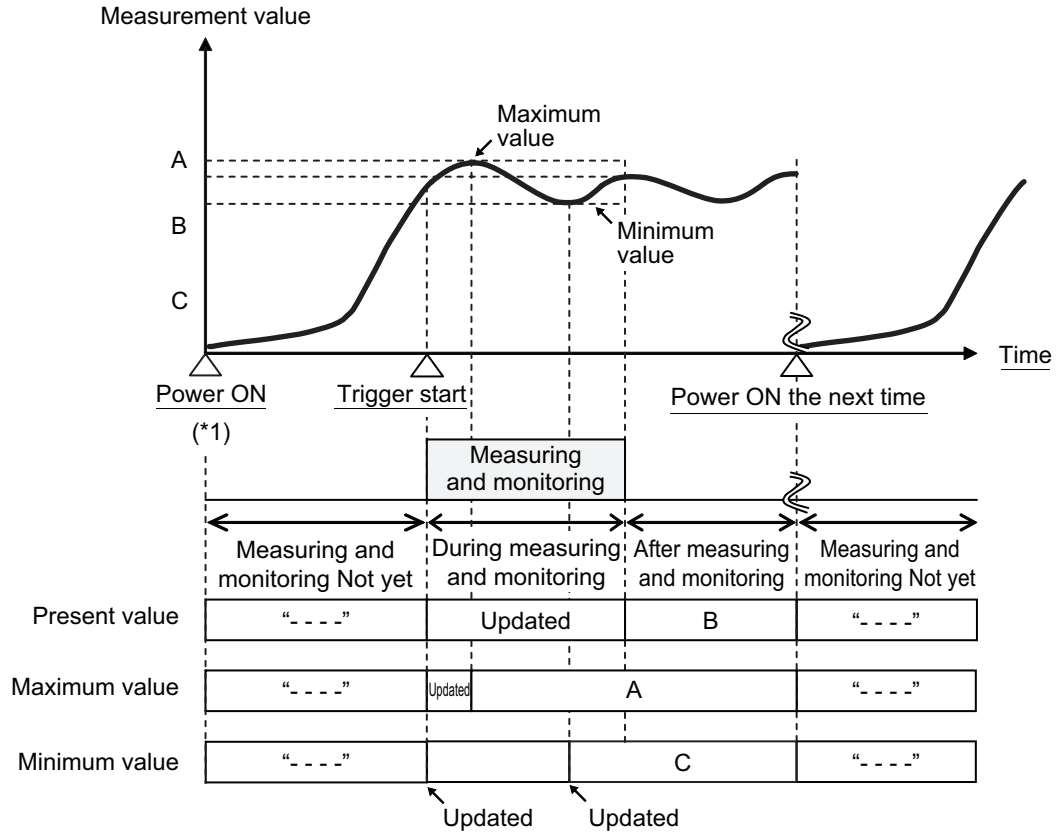

*1. In the above figure, the power-ON state and the unmeasured state (i.e., the state until the measurement value is calculated) that exist immediately after turning ON the power as shown on page 3-7 are omitted.

3-3 Monitoring System

3-3-1 Types of Individual Alarms

K6CM's individual alarm type and threshold setting range are as follows.

For individual alarms, it is possible to set the level of Warning and Critical, respectively.

For the K6CM-VBM, the threshold values can be set automatically with the software tool by using the threshold automatic setting function. For details, refer to 6-1-4 *Buttons on Device Setting* on page 6-13.

Monitor types	Model	Individual alarm type	Upper or lower limit *1	Threshold setting range	Level *1	
					Warning	Critical
Comprehensive current diagnosis type	K6CM-CI2M	Degradation level 1 alarm	Upper	0 to 9999	Yes	Yes
		Degradation level 2 alarm	Upper	0 to 9999	Yes	Yes
		Current Failure	Upper	Rating 5 A: 00.00 to 99.99 A Rating 25 A / 100 A / 200 A / 400 A / 600 A: 0.0 to 999.9 A	Yes	Yes
Vibration & temperature type	K6CM-VBM	Acceleration failure	Upper	0.00 to 99.99 G	Yes	Yes
		Velocity failure	Upper	0.00 to 99.99 ms	Yes	Yes
		Motor temperature failure	Upper	0 to 9999 deg	Yes	Yes
		Temperature gap failure	Upper	0 to 9999 deg	Yes	Yes
Insulation resistance type	K6CM-ISM	Insulation resistance failure	Lower	0.000 to 9.999 MΩ	Yes	Yes

*1. In the case of the upper limit alarm, it is necessary that the threshold of Critical > Warning is satisfied. If Critical threshold ≤ Warning threshold, the Warning threshold is ignored and only the Critical threshold exists. In the case of the lower limit alarm, it is necessary that the threshold of Critical < Warning is set. If Critical threshold ≥ Warning threshold, the Warning threshold is ignored and only the Critical threshold exists.

3-3-2 What is Comprehensive Alarm?

Comprehensive alarms are judged as integrated OR logic with the priority order as "Critical" > "Warning" > "Normal" for each individual alarm.

It is as follows.

Types of comprehensive alarm	Status
Normal	When there is neither "Critical" nor "Warning" in the individual alarm.
Warning	When there is not even one "Critical" level in the individual alarm, and at least one "Warning" level.
Critical	When there is at least one "Critical" level in the individual alarm.

Example: When the measurement value is two:

Individual alarm	Comprehensive alarm
Normal and Normal	Normal
Warning and Normal	Warning
Warning and Warning	Warning
Critical and Normal	Critical
Critical and Warning	Critical
Critical and Critical	Critical

Note To specify the type of individual alarm that exceeds the alarm threshold, operate the DISP key in the front of the K6CM device to check the measurement value by monitoring type.

3-3-3 Relationship Between Alarm and Display/Output

The relationship between the state of comprehensive alarm (Warning, Critical), alarm bar, numeric LCD display, and transistor output 1, 2 is shown below.

Described below is the case where the alarm latch is disabled and the case where it is enabled.

When the Alarm Latch is Disabled

If you set the alarm latch to "Disable (no latch)" using the software tool or message communications, the alarm condition of the comprehensive alarm (warning or critical) will not be latched.

After the comprehensive alarm (Warning or Critical) occurs, if the measurement value falls below the hysteresis (i.e., 10% of the threshold setting value) of the Warning or Critical threshold (for the upper limit alarm) or higher (for the lower limit alarm), the state of the comprehensive alarm (alarm bar and transistor outputs 1 and 2) is canceled.

● When the Trigger Mode Is "Free run (no trigger)"

When power is turned ON, measuring and monitoring are started.

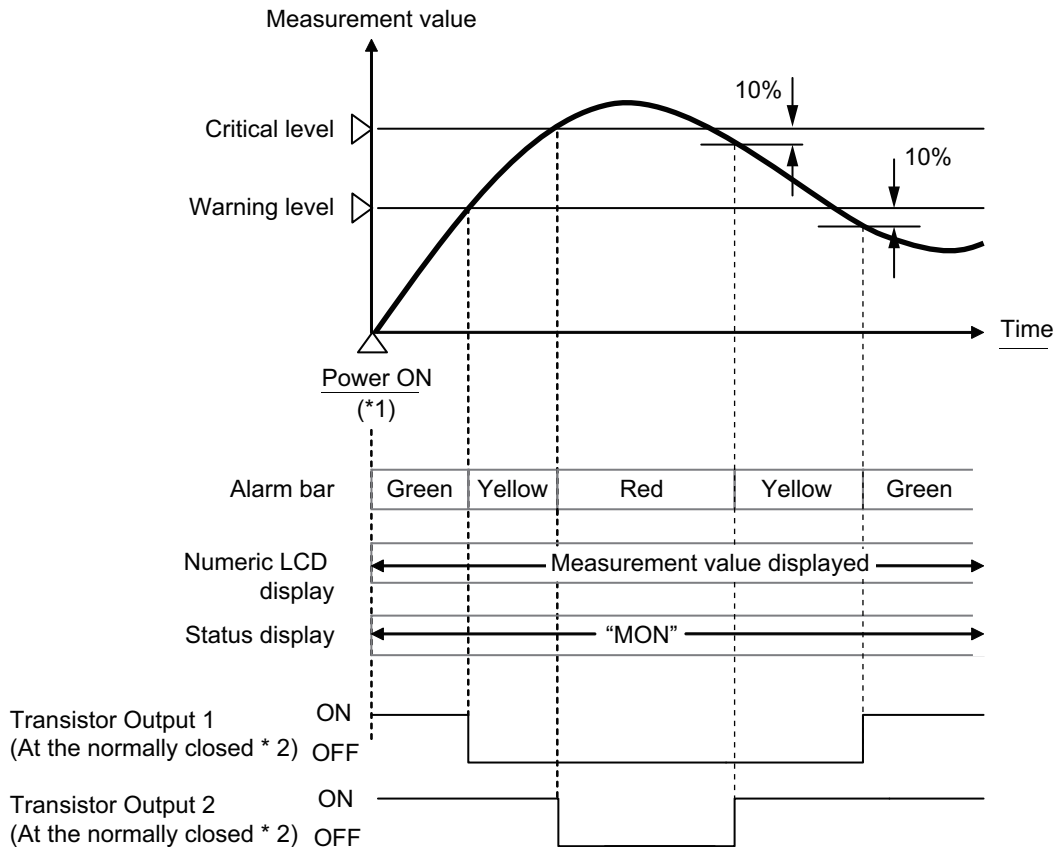

*1. In the above figure, the power-ON state and the unmeasured state (i.e., the state until the measurement value is calculated) that exist immediately after turning ON the power as shown on page 3-7 are omitted.

*2. The transistor output method of output 1 and output 2 can also be set to "Normally Open". In the case of Normally Open, ON/OFF is opposite to the above.

● **When There Is a Trigger (external trigger or internal trigger)**

The alarm bar turns off, the numeric LCD display shows "- - - -", and the transistor outputs 1 and 2 are both OFF until measuring and monitoring are started (when measuring and monitoring are not started yet).

During measuring and monitoring, the state is the same as when the trigger mode is Free run (no trigger).

After measuring and monitoring, the state at the time of measuring and monitoring end is maintained for alarm bar, numeric LCD display, transistor output 1 and 2.

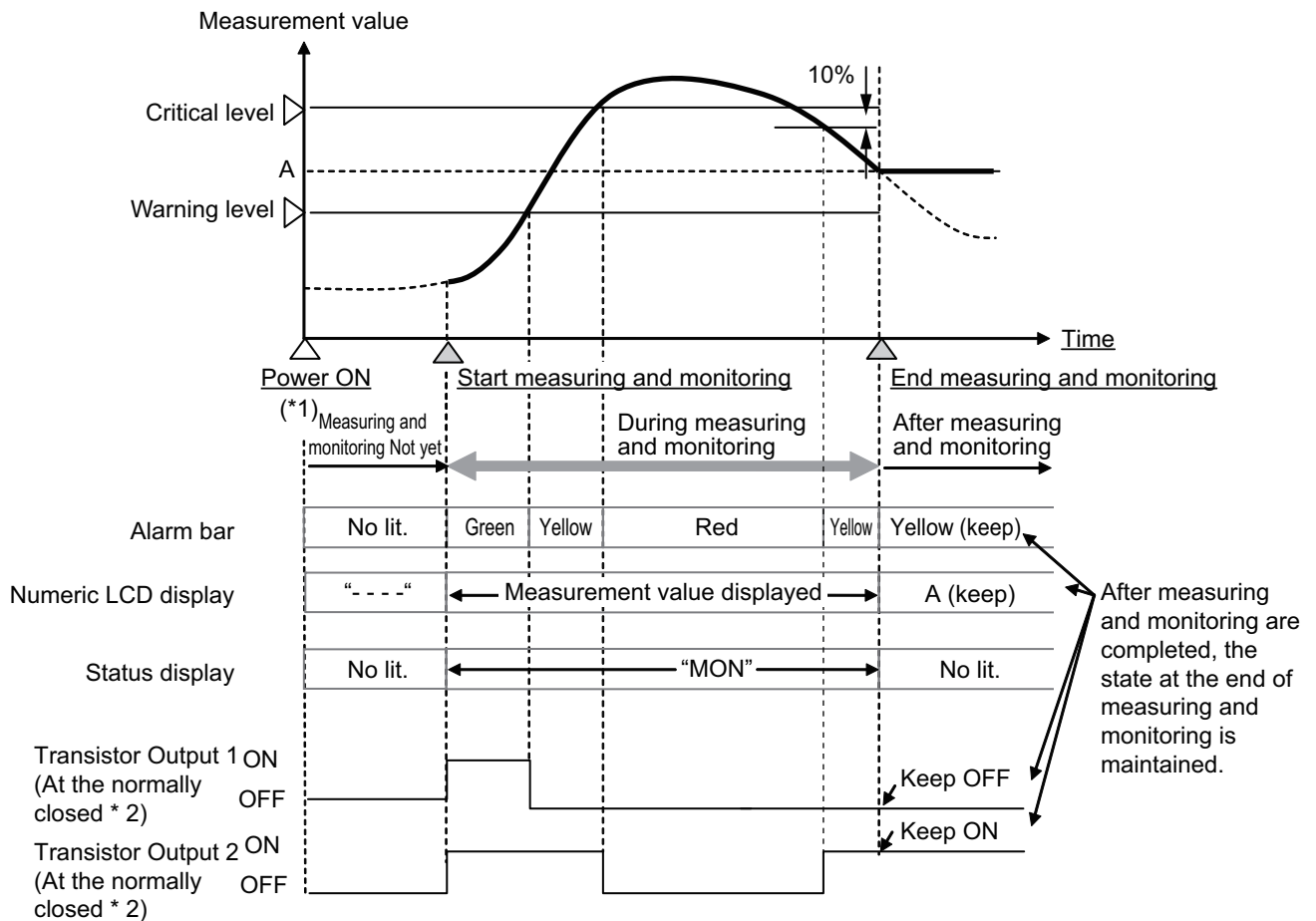

*1. In the above figure, the power-ON state and the unmeasured state (i.e., the state until the measurement value is calculated) that exist immediately after turning ON the power as shown on page 3-7 are omitted.

*2. The transistor output method of output 1 and output 2 can also be set to "Normally Open". In the case of Normally Open, ON/OFF is opposite to the above.



Precautions for Correct Use

In the upper limit alarm, if Critical threshold \leq Warning threshold, lower critical alarm, Critical threshold \geq Warning threshold, Warning threshold is ignored and Critical threshold operation is performed when only the value exists. It is as follows.

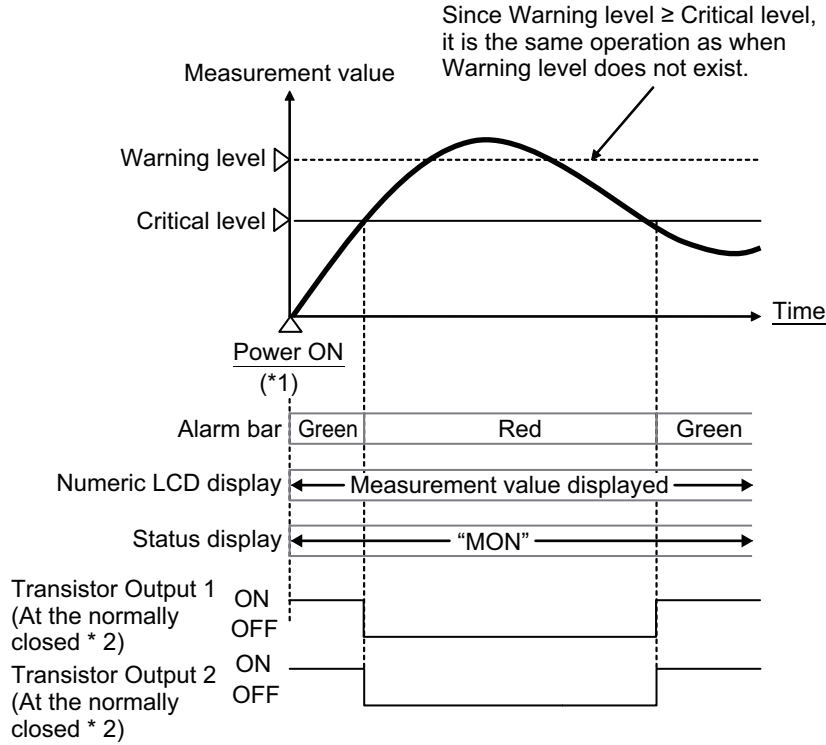

The above is an example in which the alarm latch is disabled and the trigger mode is Free run (without trigger), but in other cases the threshold of Warning is ignored.

*1. In the above figure, the power-ON state and the unmeasured state (i.e., the state until the measurement value is calculated) that exist immediately after turning ON the power as shown on page 3-7 are omitted.

*2. The transistor output type of output 1 and output 2 can also be set to "Normally Open". In the case of Normally Open, ON/OFF is opposite to the above.

When Alarm Latch is Enabled

Using the software tool or the message communications, setting the alarm latch to "Enabled" will latch the alarm condition of comprehensive alarm (warning or critical).

After the occurrence of comprehensive alarm (Warning or Critical), even if the measurement value falls below the threshold of Warning or Critical by hysteresis (10% of the threshold setting value) (upper limit alarm) or higher (lower limit alarm), Hold (alarm latch) the state of comprehensive alarm (alarm bar and transistor outputs 1 and 2).

The alarm latch is released for the first time by pressing the [ALM RST] key on the front of the K6CM device.

The operation when pressing the [ALM RST] key varies depending on the push timing as follows.

● When [ALM RST] Key Is Pressed during Measuring and Monitoring

If you press the [ALM RST] key during measuring and monitoring, both the alarm bar and transistor outputs 1 and 2 return to the comprehensive alarm state at that time.

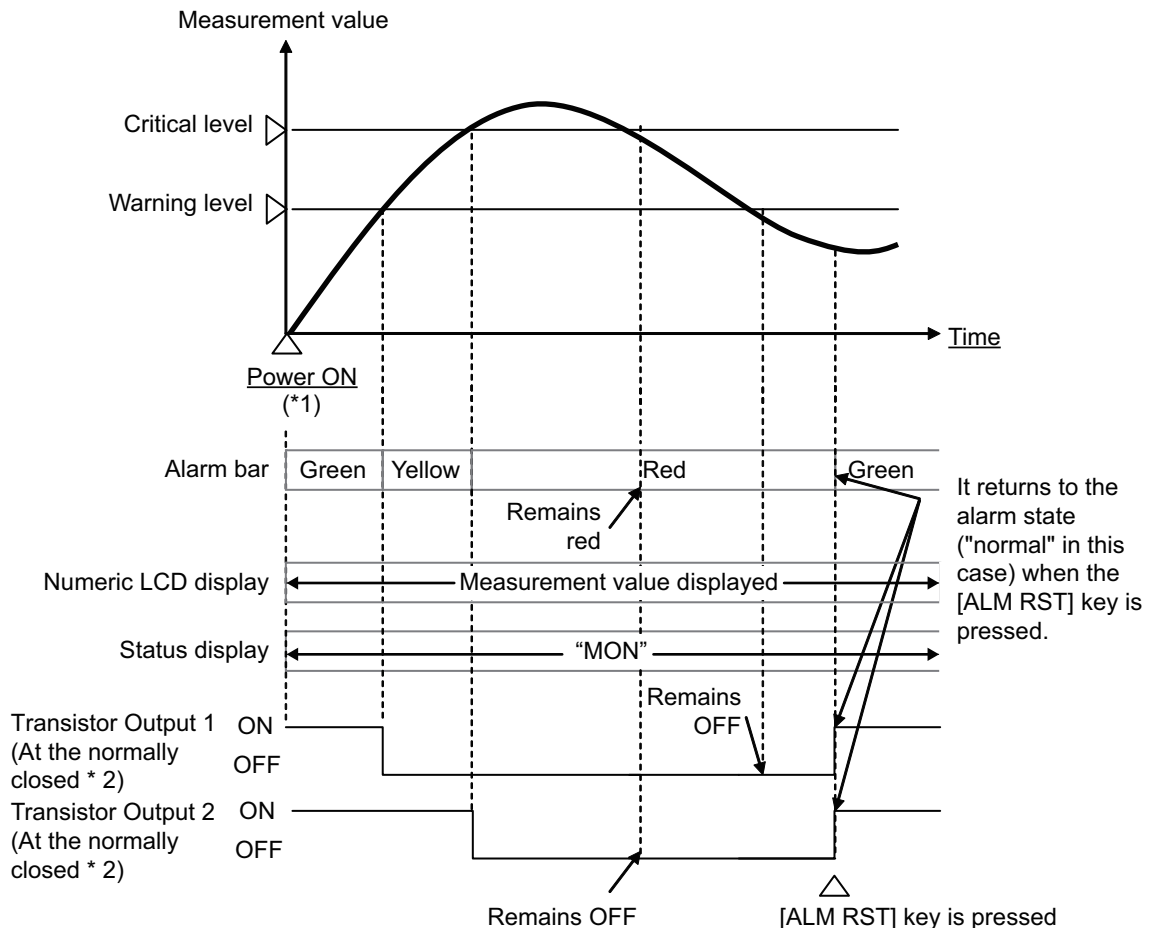

*1. In the above figure, the power-ON state and the unmeasured state (i.e., the state until the measurement value is calculated) that exist immediately after turning ON the power as shown on page 3-7 are omitted.

*2. The transistor output method of output 1 and output 2 can also be set to "Normally Open". In the case of Normally Open, ON/OFF is opposite to the above.

● **When [ALM RST] Key Is Pressed After Measuring and Monitoring**

When using the trigger function (i.e., external trigger or internal trigger), if you press the [ALM RST] key after measuring and monitoring, the alarm bar turns green and the transistor output turns on.

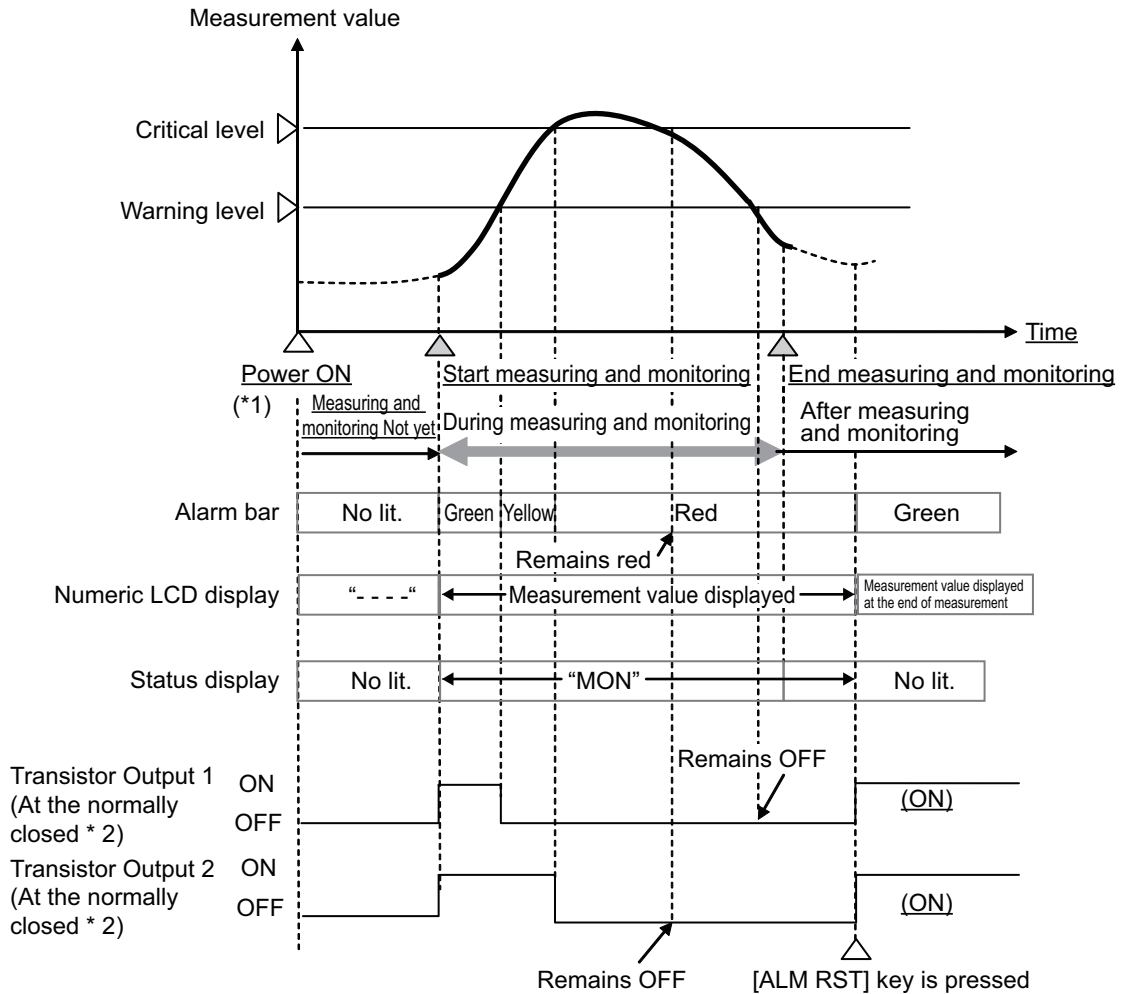

*1. In the above figure, the power-ON state and the unmeasured state (i.e., the state until the measurement value is calculated) that exist immediately after turning ON the power as shown on page 3-7 are omitted.

*2. The transistor output method of output 1 and output 2 can also be set to "Normally Open". In the case of Normally Open, ON/OFF is opposite to the above.

3-4 Guide for Setting Alarm

3-4-1 Comprehensive Current Diagnosis Type (K6CM-CI2)

Refer to the following guideline to set the alarm threshold value of the monitored degradation level in the comprehensive current diagnosis type (K6CM-CI2).

Monitoring by Degradation Level 1

- **When driving the motor by direct connection to commercial power supply**

When driving the motor without an inverter, use the following setting values at first.

- Degradation level 1 alarm threshold value (Warning): 20
- Degradation level 1 alarm threshold value (Critical): 50

Note The default value of alarm threshold (Warning) is set to 30, which is the above 20 plus 10.



Since the value of degradation level 1 differs depending on the equipment status and motor driving conditions, set alarm threshold values suitable for the equipment using the above alarm threshold values as a guide.

Refer to the *K6CM Motor Condition Monitoring Device STARTUP GUIDE (N221-E1)* for details.

- **When driving the motor with an inverter**

With an inverter, the influence of the inverter control appears in the current waveform. The degradation level 1 will be measured to be larger than the actual value.

Therefore, shift the above initial setting value in the degradation level 1 measured in a new product or the normal condition after overhauling before use.

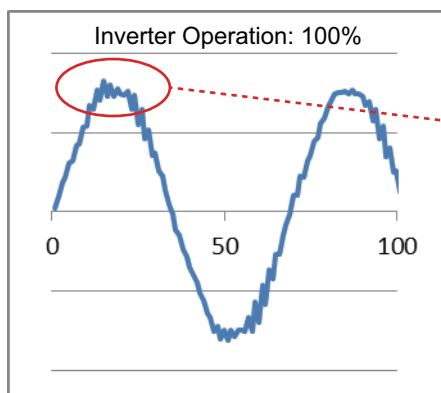

Example of actual measurement:
Initially measurement value of the degradation level 1 is "51".

Example: The degradation level 1 measured at the beginning of use is 51 due to the influence of inverter control. However, it is not abnormal.

Set the initial measurement value to 71 (51 + 20) for the degradation level 1 alarm threshold value (warning) and set the initially measurement value to 101 (51 + 50) for the degradation level 1 threshold value (critical), and then perform trend monitoring. The sensitivity of the degradation level differs depending on the equipment to be monitored, so adjust the values of 20 and 50 according to the equipment.

Note 1. When you use an inverter to drive the motor, you may not be able to monitor the abnormality of the motor or load using degradation level 1. If that happens, monitor it using degradation level 2.

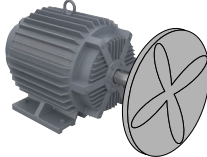
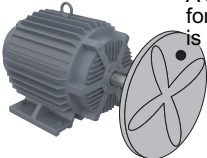
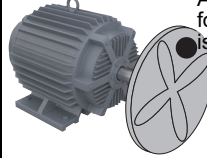
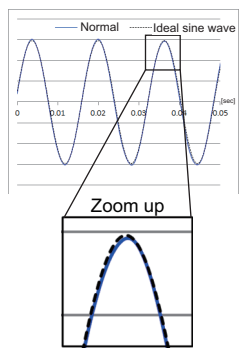
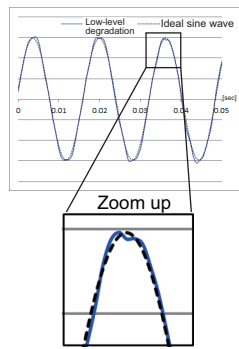
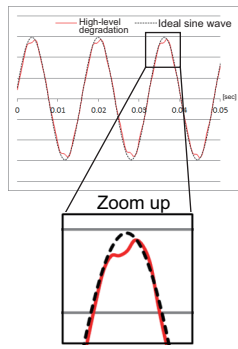
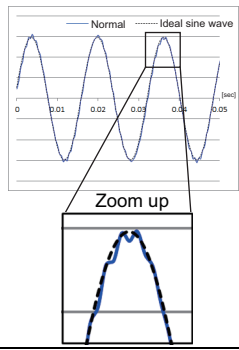
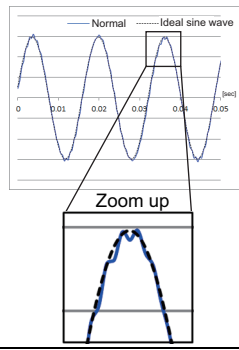
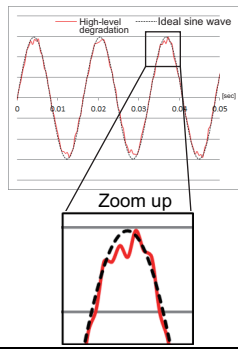
	Normal	Low-level degradation	High-level degradation
Motor condition	<p>The load balance is stable.</p> 	<p>The load balance is lost, and the force is applied unevenly to the motor shaft.</p> <p>A small foreign matter is attached.</p>  <p>Example: Small amount of a foreign matter attached to the propeller fan</p>	<p>The load balance is significantly lost, and the large force is applied unevenly to the motor shaft.</p> <p>A large foreign matter is attached.</p>  <p>Example: Adhesion of a foreign matter, or damage of propeller fan</p>
Direct connection to commercial power supply	<p>Degradation level 1: 8</p> 	<p>Degradation level 1: 24</p> 	<p>Degradation level 1: 56</p> 
	<p>Since the current waveform is almost matches the ideal sine wave, the value of degradation level 1 will small.</p>	<p>Even in Low-level degradation, since the current waveform deviates from the ideal sine wave, so the value of degradation level 1 will higher than that in the normal condition.</p>	<p>In High-level degradation, since the current waveform deviates largely from the ideal sine wave, the value of degradation level 1 will large.</p>
With inverter	<p>Degradation level 1: 50</p> 	<p>Degradation level 1: 51</p> 	<p>Degradation level 1: 61</p> 
	<p>An inverter control causes the current waveform to deviate from the ideal sine wave. Even when the motor drive is in normal condition, the value of degradation level 1 will large.</p>	<p>An inverter control causes the current waveform to deviate largely from the ideal sine wave. Therefore Low-level degradation is not shown, and the value of degradation level 1 will not be changed largely.</p>	<p>An inverter control causes the current waveform to deviate largely from the ideal sine wave. Also, the deviation from the ideal sine wave is large due to the Hi-level degradation. Therefore the value of degradation level 1 will large.</p>

The above is an example and degradation level 1 is reference value. Degradation level 1 and the current wave may vary depends on the motor.

- Degradation level 1 may vary when the motor is driven by the inverter. In that case, slightly shift the inverter drive frequency.
Also always measure and monitor degradation level 1 at the same inverter drive frequency.

Monitoring by Degradation Level 2

Use the following setting values at first.

Degradation level 2 alarm threshold value (Warning): 20

Degradation level 2 alarm threshold value (Critical): 50

Since the value of degradation level 2 differs depending on the equipment status and motor driving conditions, set alarm threshold values suitable for the equipment using the above alarm threshold values as a guide.

Refer to the *K6CM Motor Condition Monitoring Device STARTUP GUIDE (N221-E1)* for details.

● When driving the motor with an inverter

Degradation level 2 clearly captures not only the noise caused by inverter driving but also other factors such as the frequency components affecting the rotating shaft of the motor, and represents them as numerical values. Since a motor or load abnormality is captured with excellent sensitivity and the variations in the numerical values are also small compared with degradation level 1, degradation level 2 is suited to monitoring an inverter-driven three-phase induction motor.

Choose whether to use degradation level 1 or degradation level 2 depending on the equipment to be monitored.

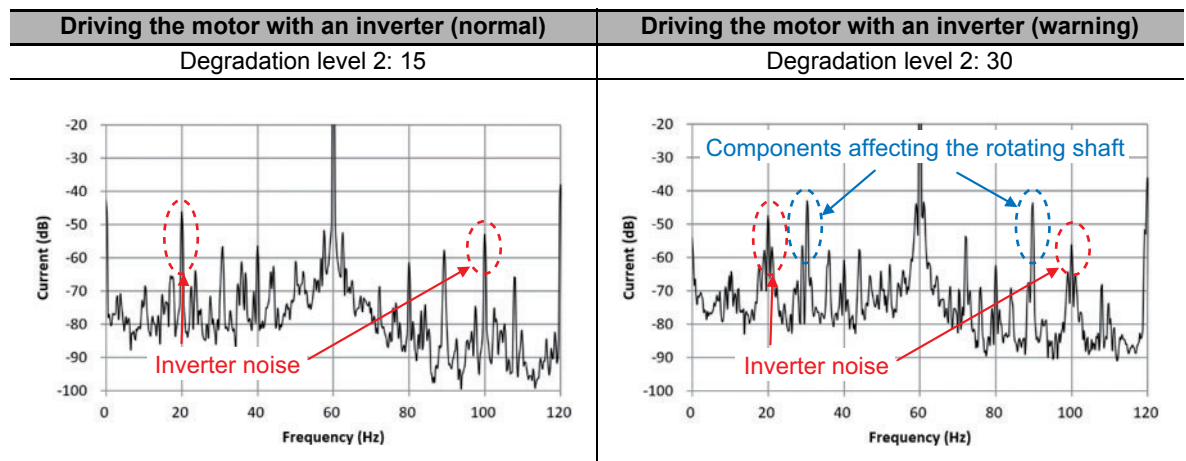

Concept for Choosing Whether to Use Degradation Level 1 or Degradation Level 2

The following describes the concept for deciding whether to use degradation level 1 or degradation level 2 for an abnormality that influences the degradation level.

Abnormality affecting degradation level	Recommended degradation level	Description
Misalignment Load imbalance Rotor abnormality	Degradation level 2	Degradation level 2 is suited to monitoring abnormalities for which certain frequency components increase because certain frequency components among the frequency components affecting the rotating shaft of the motor are clearly captured and represented as numerical values.
Cavitation, air contamination	Degradation level 1 ^{*1}	Degradation level 1 represents the degree of deviation between the whole current waveform obtained during the sampling period and the smooth sine wave of the ideal state as numerical values. Therefore, this is suited for monitoring abnormalities that have an irregular effect on the shaft of the motor.

*1. The K6CM-CIM measures only degradation level 1, so it is referred to as the degradation level in the software tool.

Choose whether to use degradation level 1 or degradation level 2 based on the trends of the measured data because the degradation level appears differently depending on the failure condition of the motor or load or depending on the installation conditions.

Degradation level 1 and degradation level 2 are both measured at the same time. Therefore, you can also monitor using both of them or just one of them depending on the abnormality you wish to monitor.



Additional Information

When measuring a 2-pole motor with degradation level 2

Since the frequency band of the harmonics of the drive frequency and the frequency band in which errors such as load imbalance and misalignment appear are the same frequency band for a 2-pole motor, sensitivity may be reduced with degradation level 2. If that happens, monitor it using degradation level 1.



Additional Information

If you want to monitor using only degradation level 1 or degradation level 2

If you want to monitor using only degradation level 1, set the alarm threshold of degradation level 2 to the maximum value (9999) so that the alarm of degradation level 2 is not output. Likewise, if you want to monitor using only degradation level 2, set the alarm threshold of degradation level 1 to the maximum value.

3-4-2 Vibration & Temperature Type (K6CM-VB)

For the Vibration & temperature type (K6CM-VB), the threshold setting method differs depending on the monitored object (i.e., acceleration, velocity) as follows.

Monitoring by Acceleration

In acceleration monitoring, you can generally monitor the bearing wears.

There are two threshold setting methods in accordance with the state of the motor.

● Monitoring by relative value

Monitor by relative value is used when it can be determined that there is no abnormality in the motor (new or overhauled).

Set the alarm threshold value referring to the table below based on the initial value that is set after installation.

Alarm	Criteria
Warning	3 to 5 times the initial value after installation
Critical	More than 5 times the initial value after installation

● Monitoring by absolute value

Monitor by absolute value is used when the motor status is unknown.

The threshold guide value is determined from the shaft diameter D [mm] of the motor to be monitored and the rotation speed N [rpm].

Refer to the figure below and set the alarm threshold.

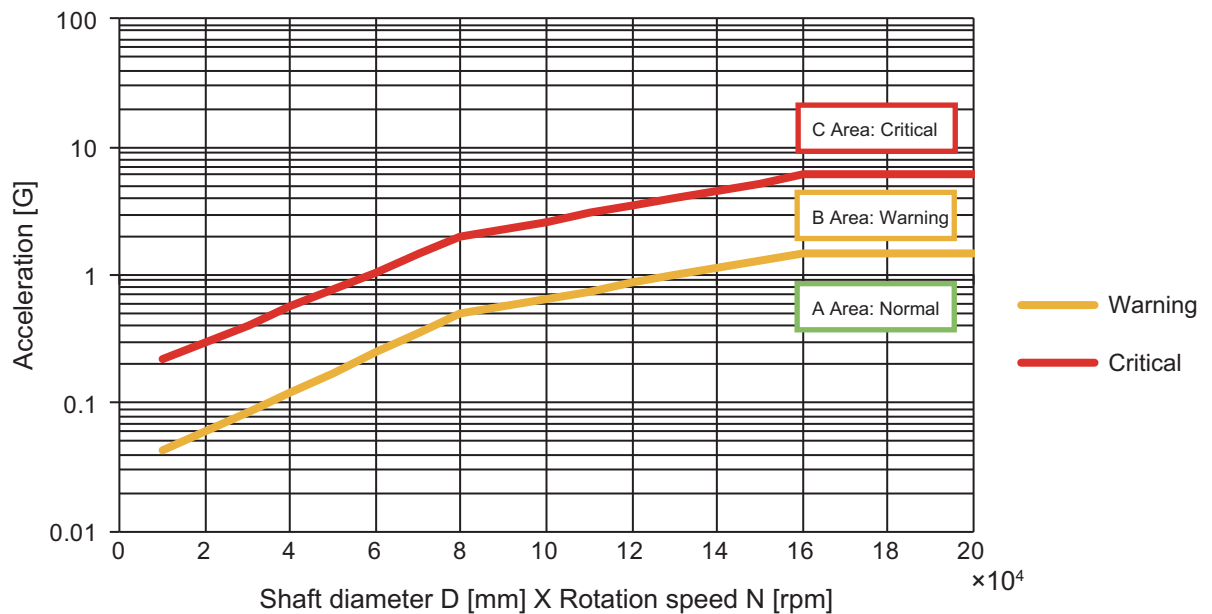

The default value of the alarm threshold is set as follows.

- Alarm threshold (Warning): 0.5 G
- Alarm threshold (Critical): 1.0 G

When the motor capacity is set to 11 kW, the shaft diameter is 42 mm, and when the 4 pole motors are directly put in the power supply (60 Hz), the rotation number is 1800 rpm. $42 \text{ mm} \times 1800 \text{ rpm} = 7.56 \times 10^4$. Based on this result of the formula, the figures are set as rounded values.

Monitoring by Velocity

In monitoring on monitoring, you can generally monitor the load imbalance, misalignment etc.

Set the alarm threshold from the class (i.e., capacity and installation status) of the motor to be monitored. Refer to the figure below and set the threshold value. (It will be set according to ISO 2372.)

Rmsvalue of vibration velocity	Class I	Class II	Class III	Class IV	Judgment
0.71 mm/s	A	A	A	A	Normal
1.12 mm/s	B				
1.80 mm/s	C	B	B		
2.80 mm/s		C			
4.50 mm/s	D	D	C	B	
7.10 mm/s			C	C	
11.20 mm/s		D	D		D
18.00 mm/s				D	Critical

The target motor class follows the table below.

Equipment class	Definition
I	Small-sized machines (typical example: motor with output less than 15 kW)
II	Medium-sized machine (typical example: motor with output of 15 kW to 75 kW or less and machine with 300 kW or less)
III	Large-sized machines: machine installed on a heavy foundation with high rigidity.
IV	Large-sized machines: machine installed on a foundation with soft rigidity.

The default value of the alarm threshold is set as follows.

- Alarm threshold (Warning): 40 mm / s
- Alarm threshold (Critical): 45 mm / s

Velocity reacts not only to vibrations but also to things like shocks. An alarm may be output due to unnecessary vibration or shock when mounting a vibration and temperature sensor. Therefore, the default value of the alarm threshold is set to a higher value. In actual use, set the alarm threshold to an appropriate value according to the monitor target.



Additional Information

If you want to monitor using only acceleration or speed

If you only want to monitor using acceleration, set the alarm threshold of speed to the maximum value (9999) so that the speed alarm is not output. Likewise, if you only want to monitor using speed, set the alarm threshold of acceleration to the maximum value.

3-5 How the Self-Diagnosis Function Works

The K6CM has a self-diagnostic function that detects its own error.

How to Notify Self-Diagnosis Error

If the self-diagnosis function determines a hardware error or a communications error between the K6CM device and the sensor, it notifies the error using display, communications and output.

● Display

When an error occurs, an error will be notified by displaying the following (1) to (4).

The display change varies depending on the type of error.

K6CM Device

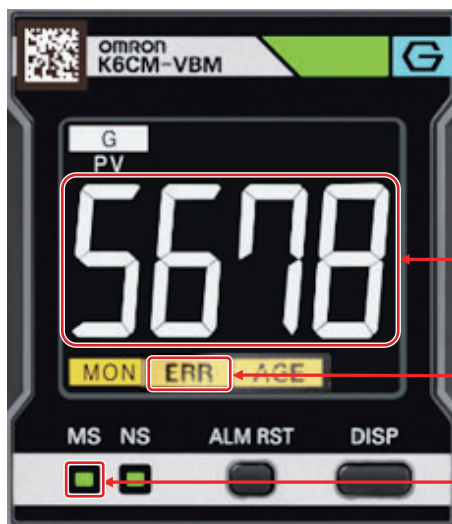

Vibration & Temperature Sensor



(1) Numeric LCD display

(2) State display

(3) Module Status display (MS indicator)

(4) Pre-amplifier fault

● Communications

The Main body status notifies the occurrence of an error to the users. It changes depending on the type of error.

● Output

Turning transistor output 3 (Tr3) OFF notifies the occurrence of an error to the users.

Behavior When Self-Diagnosis Error Occurs

● K6CM Device

Error status	Numeric LCD display	MS indicator	ERR indicator	Tr3 output	Main body status	Corrective action
Hardware errors	---- lit Or 8888 flashing	Lit red	Lit	OFF	Since the message communications cannot be performed, the Main body status cannot be read.	Turn ON the power again. If it returns to normal, the influence of noise is possible. Then, check whether noise is being generated. If the condition does not restore, contact your OMRON representative.
Communications error with Vibration & Temperature sensor or Insulation Resistance sensor	---- lit	Flashing red	Lit	OFF	Mes cpu error turns ON.	<ul style="list-style-type: none"> • Make sure that wiring is correct. • Turn ON the power again. If it returns to normal, the influence of noise is possible. Then, check whether noise is being generated. If the condition does not restore, contact your OMRON representative.
Hardware error for running time function	There is no state change due to error occurrence.	Flashing red	Lit	OFF	Main CPU error turns ON.	<ul style="list-style-type: none"> • Make sure that the ambient temperature of the K6CM device does not exceed the operating ambient temperature. • Turn ON the power again. If it returns to normal, the influence of noise is possible. Then, check whether noise is being generated. If the condition does not restore, contact your OMRON representative.

● Vibration & Temperature Sensor

Error status	Pre-amplifier fault indicator	Corrective action
Hardware errors	Lit	Turn ON the power again. If it returns to normal, the influence of noise is possible. Then, check whether noise is being generated. If the condition does not restore, contact your OMRON representative.

3-6 How the Replacement Timing Notification (i.e., Running Time Function) Works

An electrolytic capacitor is built in the K6CM device. From the manufacturing point of time, the electrolytic solution permeates through the sealing rubber and the evaporation of the electrolyte in the electrolytic solution progresses with time. As a result, deterioration of characteristics such as decrease in capacitance occurs. Due to that, the K6CM device can not exhibit sufficient performance over time.

The replacement timing announcement function indicates a guideline period until the K6CM device is unable to achieve sufficient performance due to the deterioration of electrolytic capacitor characteristics. Also, when reaching the guideline value, K6CM device front display and communications status will change. You can use this function as a guideline to know when to replace the K6CM device.

Note The replacement timing announcement indicates a guideline that the K6CM device cannot achieve sufficient performance due to deterioration of the electrolytic capacitor. The guideline does not include failures caused by other factors.

How to Notify When to Replace

When the K6CM device reaches the guideline of the replacement time, it will be notified by display and communications.

● Display

AGE indicator lit to notify users when to replace.

Note Turn ON the Use Running Time, so that the AGE LED lights up when the guideline for the replacement time is reached. The default setting of the Use Running Time is OFF.

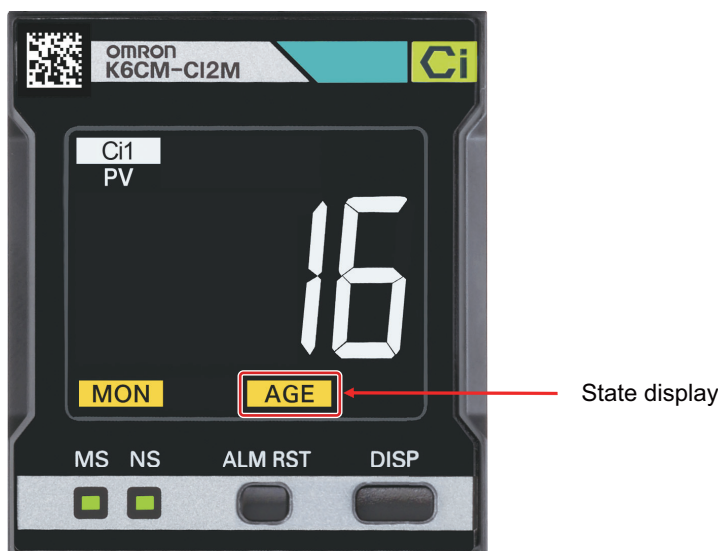

● Communications

The Running Time bit ON in the Main body status notifies users when to replace.

Also, you can see the percentage of achievement to the expected life using Running Time parameter. Running Time parameter sets the expected life to 100% and increases from 0% in 10% increments. We recommend replacing the K6CM device if the parameter reaches 100%.

3-7 Initialization of Setting Value

This section describes how to initialize the setting values of the K6CM devices.

To initialize the setting value, press the [ALM RST] key and the [DISP] key at the same time for 5 seconds or more.

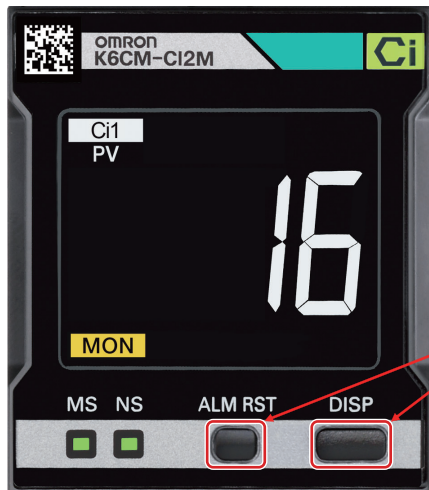

Press the keys at the same time for 5 seconds or more.

While the keys are pressed at the same time, the numeric display LCD flashes.

After 5 seconds or more, K6CM is reset, and initialization of the setting value is completed.

4

Introduction of the Motor condition monitoring Tool

This section describes the overview of the Motor condition monitoring Tool (Software Tool), and how to install it.

4

4-1 Overview	4-2
4-1-1 What is the Motor condition monitoring Tool (Software Tool) for?	4-2
4-1-2 Functions and Specifications of the Software Tool	4-3
4-1-3 Operating Environment of the Software tool	4-8
4-2 Installation and Uninstallation, Starting up	4-10
4-2-1 Installation	4-10
4-2-2 Uninstallation Procedures	4-23
4-3 IP Address Setting	4-24
4-3-1 IP Address Setting of Your PC	4-24
4-3-2 IP Address Setting of the K6CM Devices	4-26

4-1 Overview

The software tool can display the setting of K6CM devices and the present value (PV) display, and automatic logging and history display.

4-1-1 What is the Motor condition monitoring Tool (Software Tool) for?

Overview

Connect the Motor condition monitoring Tool (hereinafter referred to as software tool) to the K6CM device with an Ethernet cable, and then you can execute the following.

- **Setting up the K6CM devices**

IP address, alarm setting, and other K6CM device settings are available.

- **Monitor present value (PV) of measurement value and alarm result**

You can monitor the measurement values and the present value (PV) of the alarm results for each motor, K6CM device, and monitoring category.

- **Automatic logging and history display**

Automatically logs the measurement value and alarm result to the computer.

At the time the project saved, the logging result is automatically output to a log file (CSV file).

Based on automatically logged data and log file (CSV file), history of measurement value and alarm result is displayed.

* The project is saved along with the log file.

Setting up the K6CM Device

The following settings of the K6CM device are possible.

Setting type	Screen for setting
IP address	Create project screen or Device setting screen
Alarm setting, and other K6CM device settings	Create project screen or Device setting screen

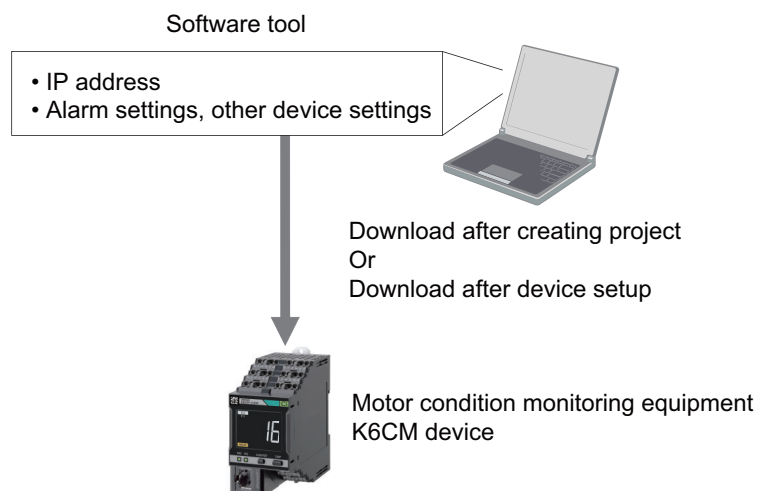

Present value (PV) Display and Automatic Logging and History Display

Present value (PV) display and automatic logging of the following data of the K6CM device are possible.

* The project is saved along with the log file.

Target data	Present value (PV) display	Automatic logging / history display
<ul style="list-style-type: none"> Measurement value Alarm result 	Display present value (PV) at specified cycle	<ul style="list-style-type: none"> Automatic logging at the same designated cycle as the left, history display possible At the end of project Save to CSV file called "log file" (For details, refer to "Log file" of <i>Details of the file to be created</i> on page 4-4.)

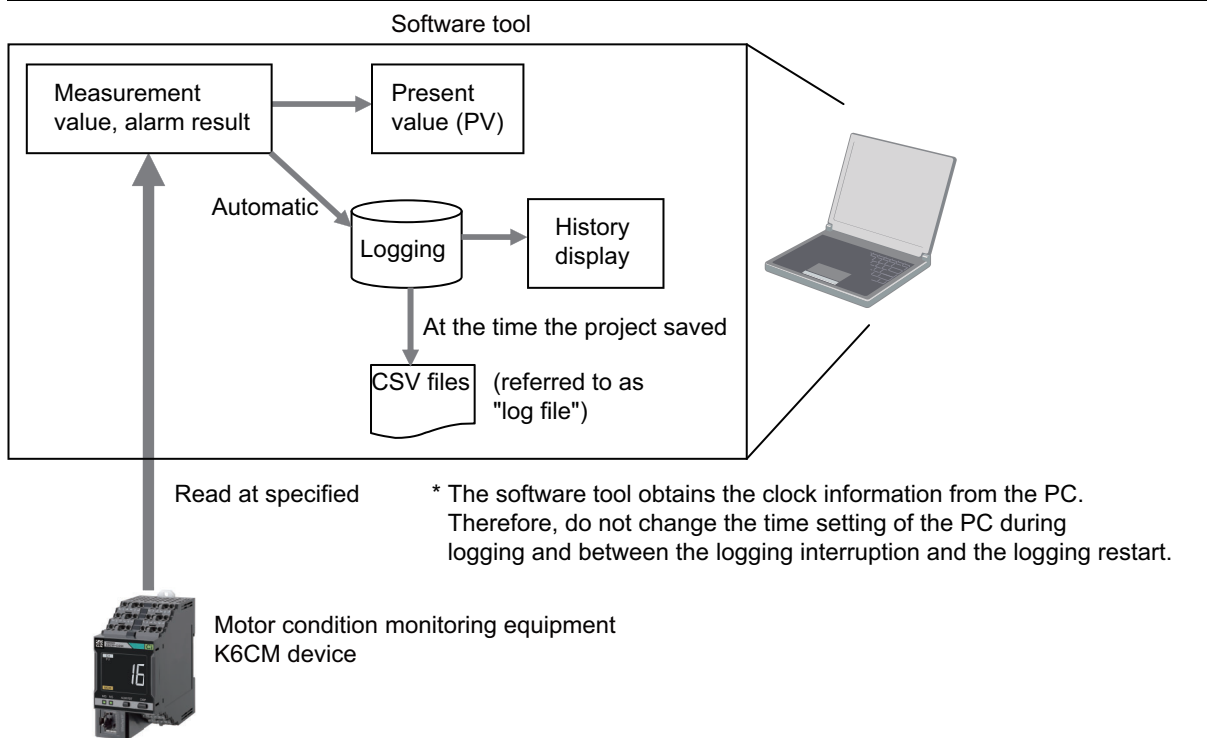

4-1-2 Functions and Specifications of the Software Tool

Item	Specifications	
Project	Number of files that can be created	No limit
Logging	Supported format	CSV data format
	Monitoring cycle	5 seconds to 366 days*1
1 Number that can be registered in the project	Number of motors	10
	Number of devices per motor	3
	Device type per motor	Only one type is possible. The same device type cannot be registered in the same motor name.
Graph display	Types of graphs	Polygonal line
	Display period *2	1 hour, 1 day, 1 month, 1 year
Files to create	The following is created in the folder of the project file name. <ul style="list-style-type: none"> Project file (binary format) Parameter file (binary format) Log file (CSV format) For details, refer to <i>Details of the file to be created</i> on the next page.	

- *1. Around 1 day for the monitoring cycle is recommended.
 If you set the monitoring cycle short, the memory capacity of the PC may run short.
 In that case, move the log file to another location and reopen the project.

Guideline number of days to move log files is as follows.

$$\text{Days} = 50 * \text{Measurement interval [seconds]} / \text{Number of connected K6CMs}$$

For example, if the monitoring cycle setting = 5 seconds, and the number of connected K6CM = 10, Move the log file to another location every 25 days and reopen the project.

- *2. In the software tool version 2.0.0 and earlier, the graph display period can be set by selecting the tabs (1 hour, 1 day, 3 months, 6 months, 1 year, 2 years, 5 years, 10 years, 20 years).
 In the software tool version 1.2.0.0 and later, you can move the graph in the time axis direction using the graph time axis movement.

● Details of the file to be created



Precautions for Correct Use

Do not use project files which are created with the software tool with the new version if you use the software tool with the older version. The software tool may not operate correctly.

File type	Extension	Description	Save position by default
Project file	.k6cm	Binary file including <ul style="list-style-type: none"> • Device configuration information including motor group • Device setting value • Event log information • Related log file information 	C: \ OMRON \ Motor condition monitoring Tool
Parameter data file	.k6pa	Binary file of parameter values for each device	Same as above

File type	Extension	Description	Save position by default
Log file	.csv	<p>Automatic log file of monitored information. It is used for graph display inside the tool. It is CSV format, so it can be used by other applications.</p> <p>File name: Project name _IIIII_TT_YYYYMMDD_NNNN.csv IIIII: Device ID (000000 to 999999) TT: Monitor type (00 to 06) 00: acceleration, 01: velocity, 02: motor temperature, 03: temperature gap, 04: insulation resistance, 05: degradation level 1, 06: current, 07: degradation level 2 YYYY: Year MM: Month (01 - 12) DD: days (01 to 31) NNNN: Serial number (the above-mentioned device ID, monitoring category, number for identifying the same date year / month / date)</p> <p>The contents of the file are as follows. One record consists of the following two lines. Line 1: [Device name], [Monitor type name] From the second line: [Date and time], [Present value (PV)], [Threshold (Warning)], [Threshold (Critical)], [Main body status], [Measurement status]</p> <ul style="list-style-type: none"> • Device name: Any one of "K6CM_VB", "K6CM_IS", "K6CM_CI" • Monitor type name: Any one of "acceleration", "velocity", "motor temperature", "temperature gap", "insulation resistance", "current", "degradation level 1", "degradation level 2" • Date and time: A character string representing the date and time on the computer system when monitoring • Present value (PV), threshold (Warning), threshold (Critical): Monitoring form Character string expressing the present value (PV), threshold value (Warning), threshold value (Critical) of K6CM device in decimal number with decimal point • Main body status, measurement status: Monitoring form Character string in hexadecimal representation of each of the 16 bits of the Main body status and measurement status of the K6CM device (Refer to the next page for details on the CSV file content and status) 	Directly under the folder of the project file name folder of the motor name
Log file	.csv	<p>Save timing:</p> <ul style="list-style-type: none"> • When saving the project. • Every hour during monitoring • When monitoring is completed • When you select to save log files and project files at the end of the software tool <p>*1 The project is saved along with the log file. When log file is open, data is not saved. If you want to open the log file during monitoring, we recommend copying it to another folder.</p> <p>*2 The maximum number of lines of the log file is 10,000 lines. If it exceeds the maximum number of lines, create a new log file and save the log.</p>	Directly under the folder of the project file name folder of the motor name

Log file example

The display example of the log file concerning the degradation level 1 with the comprehensive current diagnosis type is shown below.

When the monitoring cycle setting of the software tool is set to 86,400 seconds (= 1 day) ...

Data is saved every day.

The alarm values which are set in the K6CM device are displayed.

The status changes depending on the status of input/output and measurement values.

	A	B	C	D	E	F
1	K6CM_CI	Degradation level 1				
2	Date	Degradation level 1 pv	Degradation level 1 failure warning	Degradation level 1 failure critical	Main body status	Degradation level 1 status
3	11/17/2017 4:10:00 PM	7	30		50 E200	0
4	11/17/2017 4:10:05 PM	8	30		50 E200	0
5	11/17/2017 4:10:11 PM	8	30		50 E200	0
6	11/17/2017 4:10:16 PM	7	30		50 E200	0
7	11/17/2017 4:10:22 PM	8	30		50 E200	0
If the motor degrades						
41	11/17/2017 4:13:31 PM	31	30		50 C200	0
42	11/17/2017 4:13:37 PM	31	30		50 C200	0

The degradation level 1 pv exceeded the degradation level 1 failure warning and an alarm was output. The Main body status and the degradation level status have changed according to those states.

For the Main body status and the individual monitoring status, refer to the table below.

Main body status

Bit position	Status	Bit contents	
		0	1
0	Mes cpu error	Not occurred	Occurrence
1	Mes cpu data flash error	Not occurred	Occurrence
2	Main CPU error	Not occurred	Occurrence
3	Main CPU data flash error	Not occurred	Occurrence
4	Reserved area		
5	Reserved area		
6	Reserved area		
7	Reserved area		
8	Running Time status	Unreached	Reached
9	Monitoring condition	Monitoring stopped	During monitoring
10	Reserved area		
11	Reserved area		
12	Trigger input (ON/OFF state of the external trigger input)	OFF	ON
13	Tr1 (transistor 1 output state)	OFF	ON
14	Tr2 (transistor 2 output state)	OFF	ON
15	Tr3 (transistor 3 output state)	OFF	ON

Individual monitoring status (common form of individual measurement value)

Bit position	Status	Bit contents	
		0	1
00	Present value unmeasured state	Measured status	Unmeasured status
01	Present value input error	Not occurred	Occurrence
02	Reserved area		
03	Reserved area		
04	Maximum value unmeasured state	Measured status	Unmeasured status
05	Maximum value input error	Not occurred	Occurrence
06	Reserved area		
07	Reserved area		
08	Minimum value unmeasured state	Measured status	Unmeasured status
09	Minimum value input error	Not occurred	Occurrence
10	Reserved area		
11	Reserved area		
12	Individual alarm result (Warning)	No alarm	Alarm occurrence
13	Individual alarm result (Critical)	No alarm	Alarm occurrence
14	Reserved area		
15	Reserved area		

In the example of the status of [2018/3/5 7:25] in the log file example on the previous page, the character string of the Main body status is "C200" and that of the individual monitoring status is "1000".

"C200" and "1000" are hexadecimal numbers, so convert them to binary numbers.

Main body status

Hexadecimal	C	2	0	0
Binary	1100	0010	0000	0000

Individual monitoring status

Hexadecimal	1	0	0	0
Binary	0001	0000	0000	0000

The bit positions are 15, 14, ... , 1, and 0 from the left.

In the above case, the Main body status 15th, 14th and 9th bits are all "1", so the measurement state is "During monitoring" and Tr1 is "OFF" and both Tr2 and Tr3 are "ON".

Likewise for the individual monitoring status, the 12th bit is "1", so the individual alarm result (Warning) is "Alarm occurrence".

Note When the above status is "0001" or "0110" for example, the value displayed in the CSV file is like "1" or "110" without the last "0".

4-1-3 Operating Environment of the Software tool

Item	Description
OS	Windows 7, Windows 8.1, Windows 10 (32 bit / 64 bit) (JP / EN)
CPU	1 GHz or more, 32 bit or 64 bit processor
Memory	1 GB or more, or 2 GB or more (in the case of 64 bits)
Disk reserved area capacity	16 GB or more, or 20 GB or more (in the case of 64 bits)
Monitor resolution	1024 × 768 (XGA), High Color 16 bit or more
.NET Framework	.NET Framework 4 and .NET Framework 3.5
Communications driver	SYSMAC Gateway Ver.1.7.1.0 or higher (included) *1
Others	CD-ROM drive: For installation LAN port: For network connection

*1. The operation requires .NET Framework 3.5 SP1.

Software tools can be installed on the CD-ROM included with the K6CM device.

The following data is stored on the CD-ROM.

Contents	Description	Location
Software tool	This is a computer software that sets K6CM devices, displays the present value (PV) of K6CM devices, and implements automatic logging and history display.	CD drive\setup.exe
SYSMAC Gateway CX-Compolet	This is the communications driver used by the Motor condition monitoring Tool. *1	CD drive\SGW CD drive\CX-Compolet
Communications Middleware	This is a middleware necessary for automatic connection with the K6CM devices when using the Motor condition monitoring Tool.	CD drive\middleware
K6CM Motor Condition Monitoring Device User's Manual	This is the user's manual of the K6CM device.	Japanese manual CD drive\Manual\K6CM_Manual_J.pdf English manual CD drive\Manual\K6CM_Manual_E.pdf
CX-Compolet Installation Guide	This is the installation guide for the CX-Compolet.	Japanese guide CD drive\Manual\CX-Compolet_SGW_InstallationGuide_J.pdf English guide CD drive\Manual\CX-Compolet_SGW_InstallationGuide_E.pdf
Startup Guide	This is a guide that describes the simple procedures and operation method on the startup of the K6CM devices.	Japanese guide CD drive\StartupGuide\SGTE-721□.pdf English guide CD drive\StartupGuide\N221-E1-□□.pdf * The part of □ is a revision symbol.
.Net Framework3.5 SP1	This is an installer for application development and execution environment provided by Microsoft Corporation. Required when using the Motor condition monitoring Tool.	.Net Framework 3.5 SP1 Installer CD drive\Framework\dotnetfx35.exe Japanese 32 BitOS language pack CD drive\Framework\dotnetfx35langpack_x64ja.exe Japanese 64 BitOS language pack CD drive\Framework\dotnetfx35langpack_x86ja.exe
EDS file	This file contains information on the device. Install the EDS file in the configuration tool and use it.	Comprehensive current diagnosis Type CD drive\EDS\K6CM_CI2M_EIP_R3.eds*2 Vibration & Temperature Type CD drive\EDS\K6CM_VBM_EIP_R3.eds*2 Insulation Resistance Type CD drive\EDS\K6CM_ISM_EIP_R3.eds*2

Contents	Description	Location
Sample program for NJ/NX-series*2	This is a sample program for monitoring the motor condition using the NJ/NX-series Controller.	Sample program: Japanese edition: CD drive \ SampleProgram \ Program \ SampleProgram_V1_2_0.smc2 English edition: CD drive \ SampleProgram \ Program \ SampleProgram_E_V1_2_0.smc2 Function block (sample): CD drive \ SampleProgram \ FunctionBlock \ SampleF-B_EN_K6CM_Read_V1_2_0.slr

- *1. If you use the SYSMAC Gateway and the CX-Compolet for purposes other than using the Motor condition monitoring Tool, please purchase those licenses.
- *2. It is added from the software tool version 1.1.0.0. For the version of the software tool, check the printing of CD-ROM. With the update program of our I-Web, you can update the software tool of the old version to the latest version.

4-2 Installation and Uninstallation, Starting up

This section describes how to install and uninstall the software tool and how to start it.

4-2-1 Installation

● Installing .NET Framework 3.5 SP1

The software tool requires Microsoft .NET Framework 3.5 SP1 to run the program.

If .NET Framework 3.5 SP1 is not installed on your computer, install it manually.

It is installed as a standard on Windows 7 computer. Follow steps 2 to 4 below.

It is not installed as a standard on Windows 8.1 and Windows 10 computer.

When using on a computer with Windows 8.1 or Windows 10, perform the steps 2 to 4 after installing the .NET Framework 3.5 SP1 shown in the following step 1.

1 Install .NET Framework 3.5 SP1.

● Installing by connecting the computer to the network

(1) Install it by "dotnetfx35.exe" in the Framework folder on the CD.

(2) Install the language pack with the following files in the Framework folder in the CD.

Japanese 32bit OS: "dotnetfx35langpack_x86ja.exe"

Japanese 64 Bit OS: "dotnetfx35langpack_x64ja.exe"

● Installing without connecting the computer to the network

This procedure shows how to install the software tool (and attached software) on PCs (Windows 8.1 or Windows 10 OS) that cannot connect to the network.

What are required to prepare:

- Network connected computer
- Empty recording medium (USB memory of 8GB or more, HDD or DVD)

This procedure also details the resolution technique published on the following Microsoft official website.

Microsoft official website URL:[https://msdn.microsoft.com/en-US/library/windows/hardware/dn898529\(v=vs.85\).aspx#nointerent](https://msdn.microsoft.com/en-US/library/windows/hardware/dn898529(v=vs.85).aspx#nointerent)

Note In Windows version 8.1 or later OS version, the "Microsoft .NET Framework 3.5" required for installing the above mentioned attached software is not installed in advance. Therefore, if you are using a computer with the above OS version and cannot connect to the network, you cannot acquire the above .NET and you cannot install the software included with the software tool.

Outline of this procedure

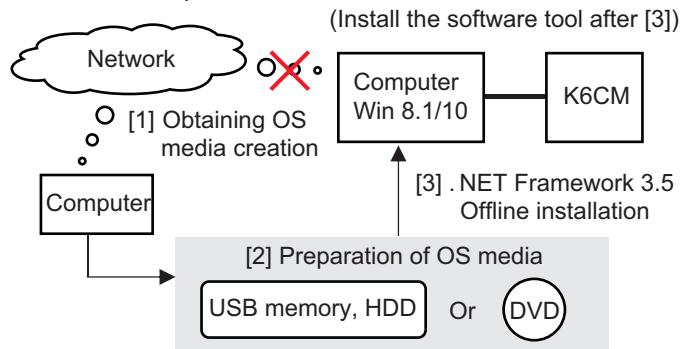

(1) Acquire OS media creation tool

To create the OS media that matches the Windows version of the computer you want to install the software tool, download the OS media creation tool "MediaCreationTool.exe" from the official Microsoft page at the following URL.

Windows 8.1

<https://www.microsoft.com/en-us/software-download/windows8>

Windows 10:

<https://www.microsoft.com/en-us/software-download/windows10>

Note If you do not know the Windows version of your computer, perform the following procedure.

- 1) Hold down the Windows key and press the R key.

Alternatively, click [Run] from the [Start] menu.

- 2) Enter "winver" and click [OK].Button.

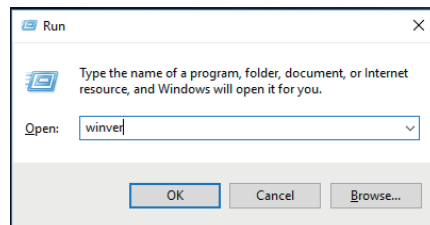

- 3) The Windows version is displayed, so confirm.

(2) OS media creation

Run the downloaded OS media creation tool.

Be sure to select "Create installation media of another PC" for the option after agreeing to the license terms.

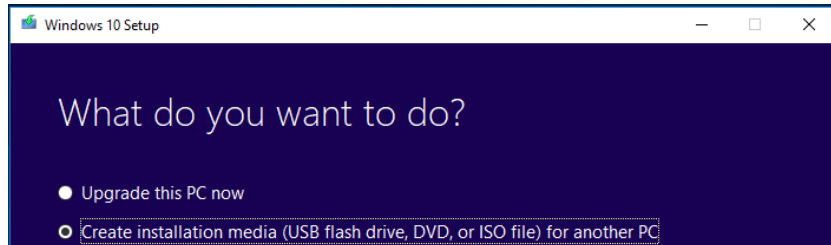

In the selection screen of language, architecture, and edition, uncheck the check box at the bottom and select the same one as the computer you want to install the software tool.

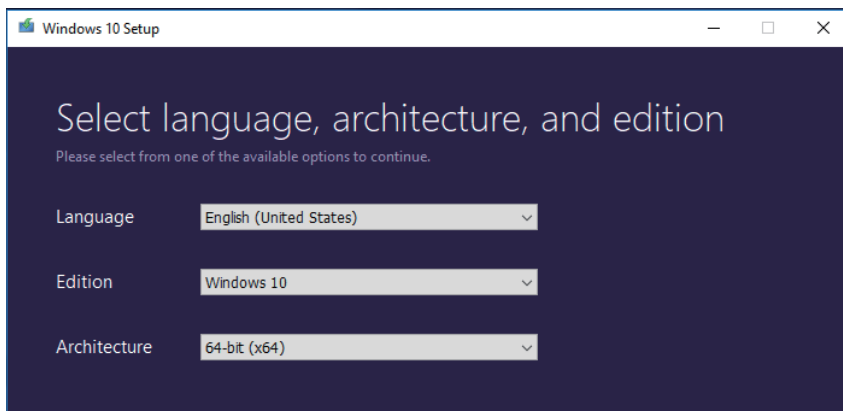

Note If you do not know the architecture of your computer, perform the following procedure.

- 1) On the personal computer where you want to install the software tool, hold down the Windows key and press the R key.

Alternatively, click [Run] from the [Start] menu.

- 2) Enter "cmd" and click OK. A command prompt is launched.
- 3) Enter "echo %processor_architecture%" and press Enter key.

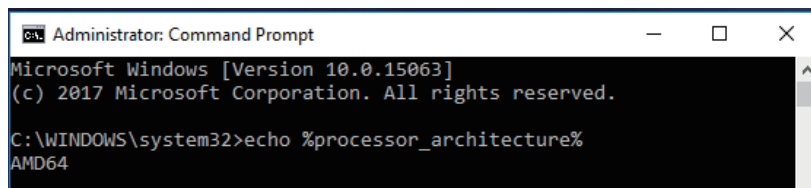

- 4) 32 bits are displayed as x86, 64 bits are displayed as x64, and so on.

Select the media type to use.

When selecting "USB flash drive", be sure to prepare an empty recording medium (USB memory of 8 GB or more, HDD or DVD) without data.

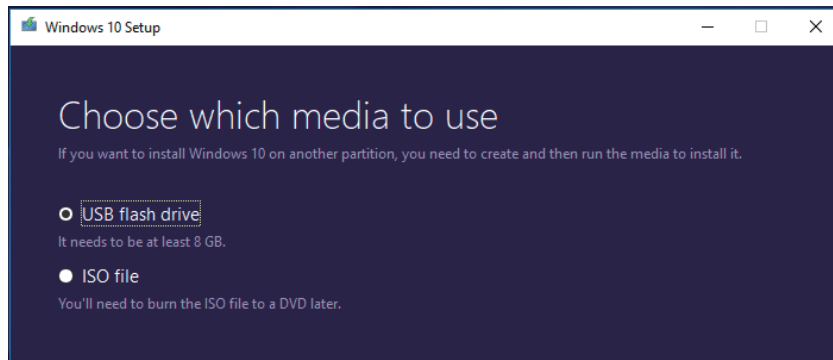

At this point, connect the USB memory to your computer and select "Next" on the installation screen. Confirm that the USB memory is normally recognized by the computer and displayed as a removable drive as below and proceed with creating OS media.

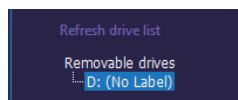

(3) .NET Framework 3.5 Offline installation

Make the software tool recognize the created OS media on the PC you want to install (If you are using a USB memory or HDD, connect it to a PC, mount it on a PC if it is a DVD).

When the OS media is recognized correctly, the following popup will be displayed. In this example, you can see that the USB memory as the OS media has been assigned to D drive (D :).

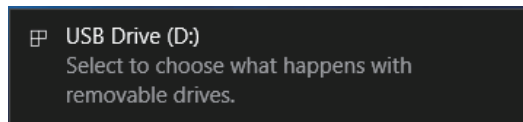

As we will use the drive information we have confirmed in the later operation, be sure to check which drive the OS media is assigned to.

Note It is possible to check the media with other methods. Click the Explorer icon located at the bottom of the desktop screen. (If there is no icon, hold down the Windows key and press the E key to start the explorer screen)



Since the Explorer screen starts, click the drive icon displayed on the left side of the screen that started up. If the OS media is recognized correctly, the drive containing the following data will be displayed.

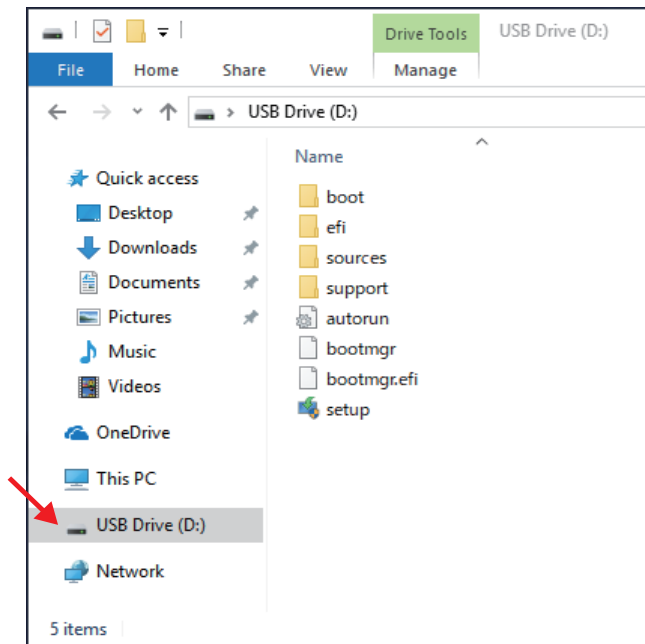

Execute the command prompt (shell script) with administrator privileges after confirming that the OS media was recognized correctly.

Hold down the Windows key while pressing the X key, the following screen will be displayed, so select Windows PowerShell (Administrator).

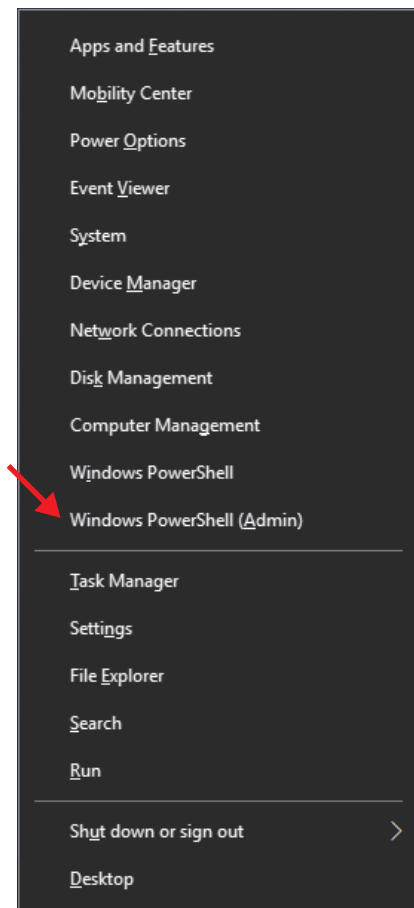

After that, confirm that the following command prompt screen is displayed.

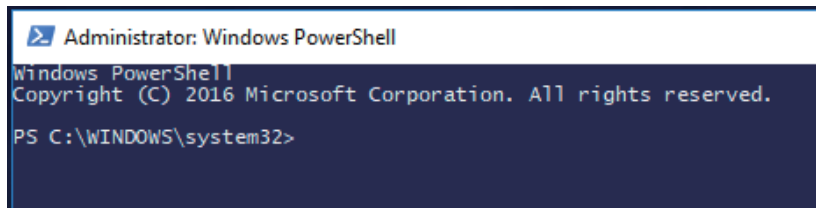

```
Administrator: Windows PowerShell
Windows PowerShell
Copyright (C) 2016 Microsoft Corporation. All rights reserved.
PS C:\WINDOWS\system32>
```

Enter the following command and press Enter to execute. In the command, "D:" is the drive to which the OS media checked earlier was assigned. Depending on the user environment used.

As you can see, be sure to modify the command according to the drive information you have confirmed.

Command:

```
Dism /Online /Enable-Feature /FeatureName:NetFX3 /All/Source:D:\Sources\SxS /LimitAccess
```

Note Enter the command on one line without line break. Insert a space between Dism and the set of words (/ ***) that compose the command.

Wait for a while until the completion screen as shown below. If this screen can be confirmed, the installation of .NET Framework 3.5 will be completed, continue installing the software tool.

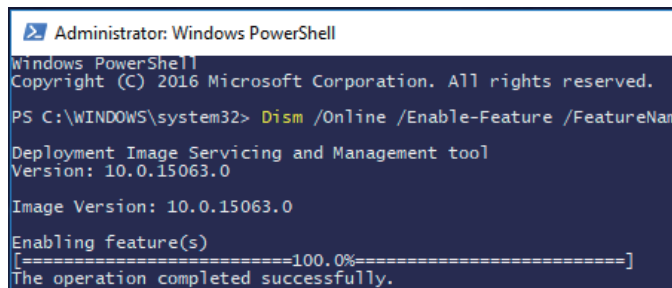

```
Administrator: Windows PowerShell
Windows PowerShell
Copyright (C) 2016 Microsoft Corporation. All rights reserved.
PS C:\WINDOWS\system32> Dism /Online /Enable-Feature /FeatureName
Deployment Image Servicing and Management tool
Version: 10.0.15063.0
Image Version: 10.0.15063.0
Enabling feature(s)
[=====100.0%=====]
The operation completed successfully.
```

2 Select "Program" from the Control Panel.

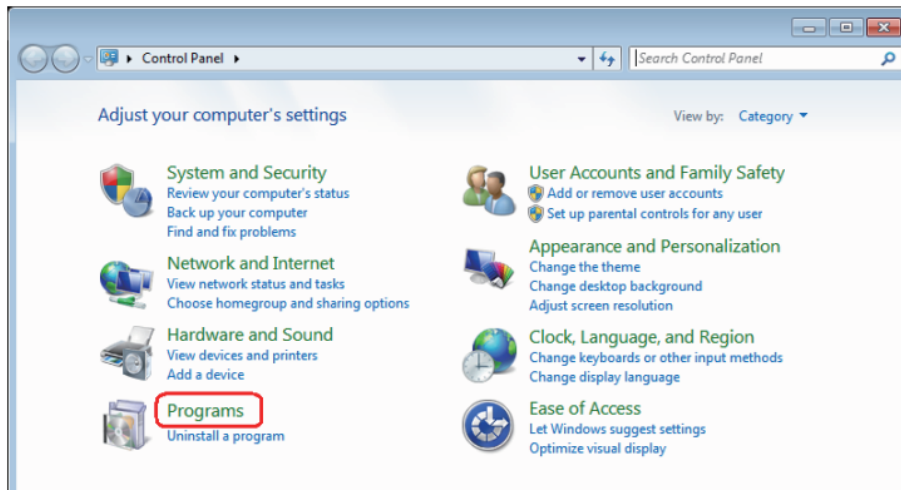

3 Turn on or off Windows functions.

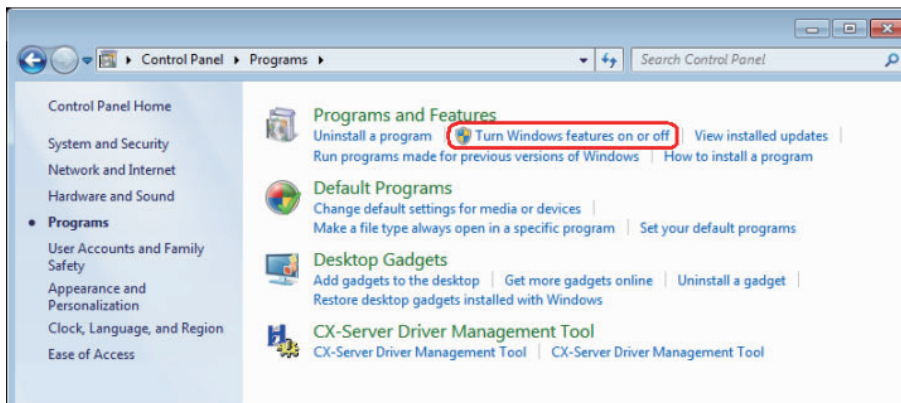

4 Check the check box of "Microsoft .NET Framework 3.5.1" and click "OK".

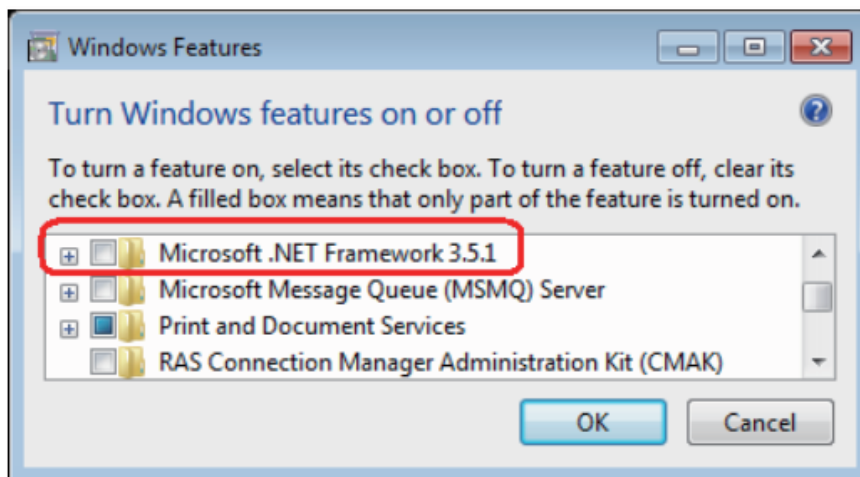

Installing the Software Tool

This section shows the procedure for installing a new software tool.



Precautions for Correct Use

"User account control" may be displayed depending on computer settings during installation procedure. In that case, click "yes" if there is no problem.

1

Insert the attached CD in the computer and select "setup.exe" from the autoplay screen. If automatic playback was not done, double-click the "setup.exe" file under the CD drive. The following [Select language setting] Dialog Box will be displayed.

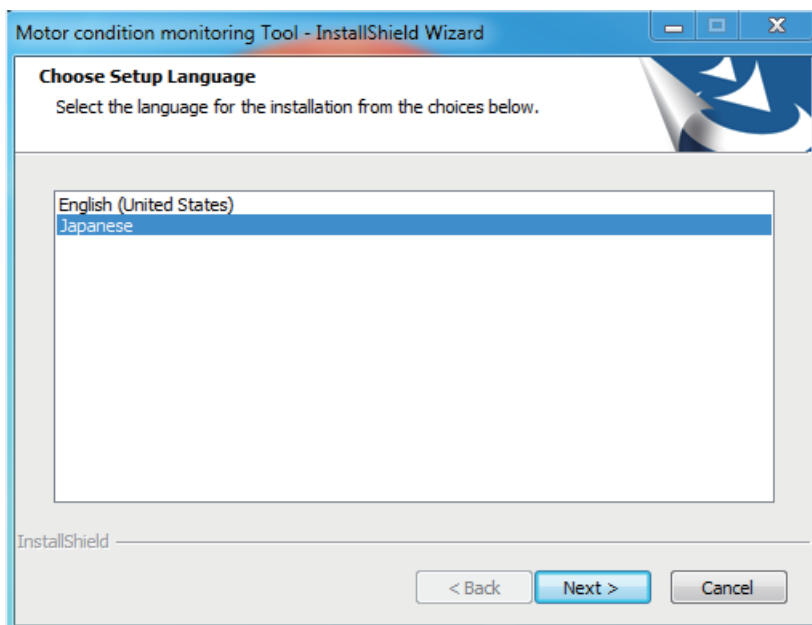

Precautions for Correct Use

If the following message is displayed, the old version of CX-Compolet/SYSMAC Gateway has already been installed on the computer. In order to use software tool, upgrade of CX-Compolet/SYSMAC Gateway is necessary.

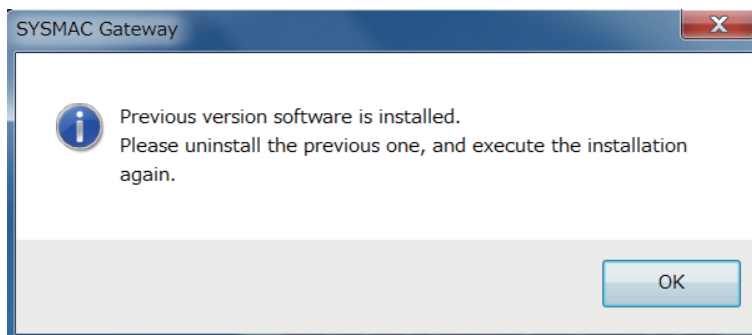

Please read "3.5. Upgrade installation" of "CX-Compolet_SGW_InstallationGuide_E.pdf" in the Manual folder on the CD and uninstall the CX-Compolet/SYSMAC Gateway after backing up the data. Then re-perform step 1.



Precautions for Correct Use

If the following message is displayed, a newer version of the software tool than the launched installer has already been installed on your PC. Therefore, installation is unnecessary.

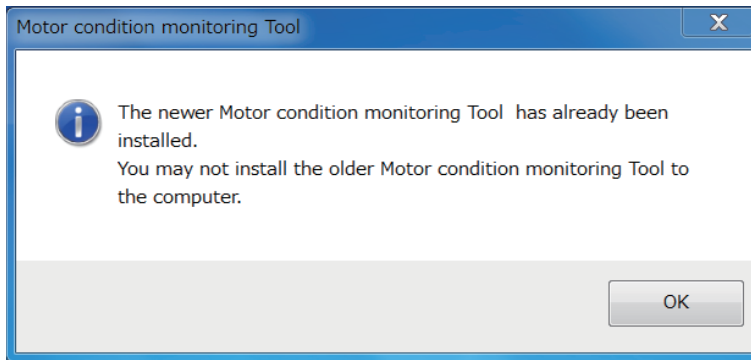

Precautions for Correct Use

If the following message is displayed, a software tool of the same version as the launched installer has already been installed in your PC.

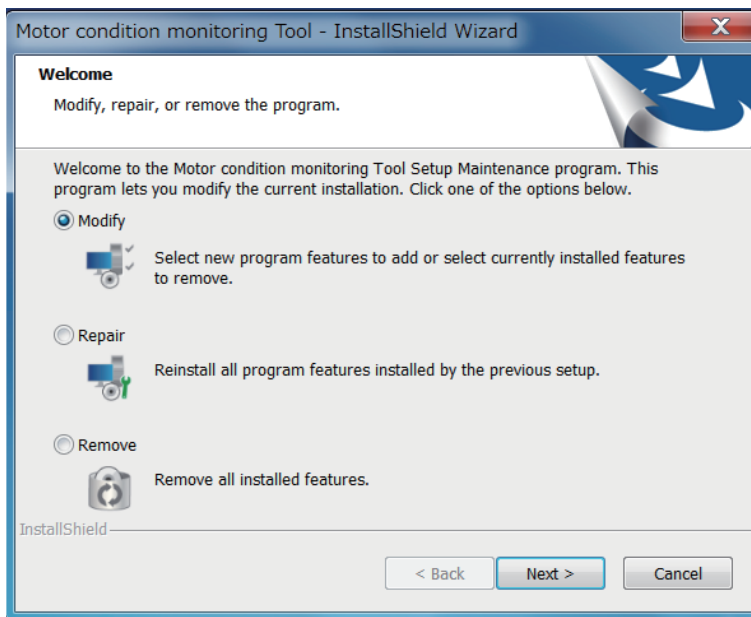

[Modify] is used to change the function to be installed. Do not use it now for future expansion.

[Repair] is used to reinstall the software tool.

[Remove] is used to uninstall the software tool.



Precautions for Correct Use

If the following message is displayed, a older version of the software tool than the launched installer is installed on your PC.

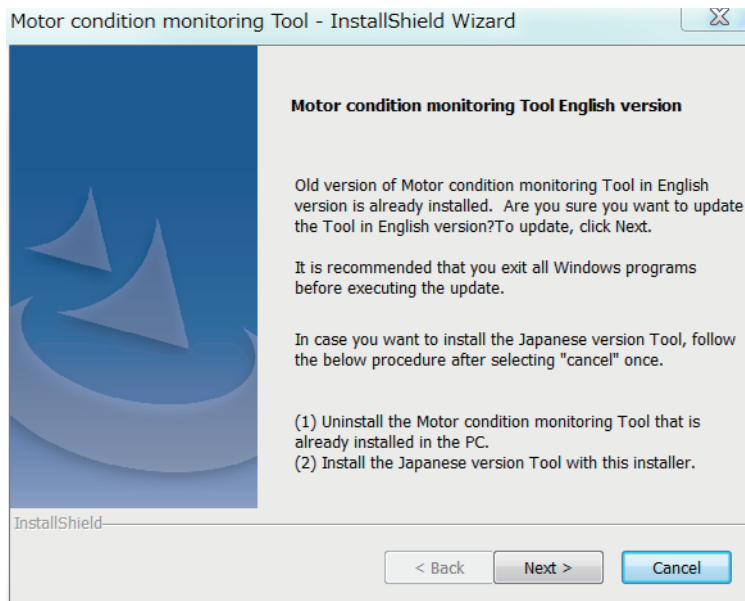

To update the software tool, click [Next] Button. Start updating after clicking. When the update is completed, a completion message is displayed.

- 2** Select "Japanese" or "English" and click the [Next] Button.
The following Dialog Box will be displayed.

- * If you select Japanese on your PC with other than Japanese OS, depending on the environment of your PC, the characters during installation may not be displayed correctly, or the software tool may not work properly.
- * After installation, you cannot change the language of the software tool. If you want to change the language, reinstall the software tool.

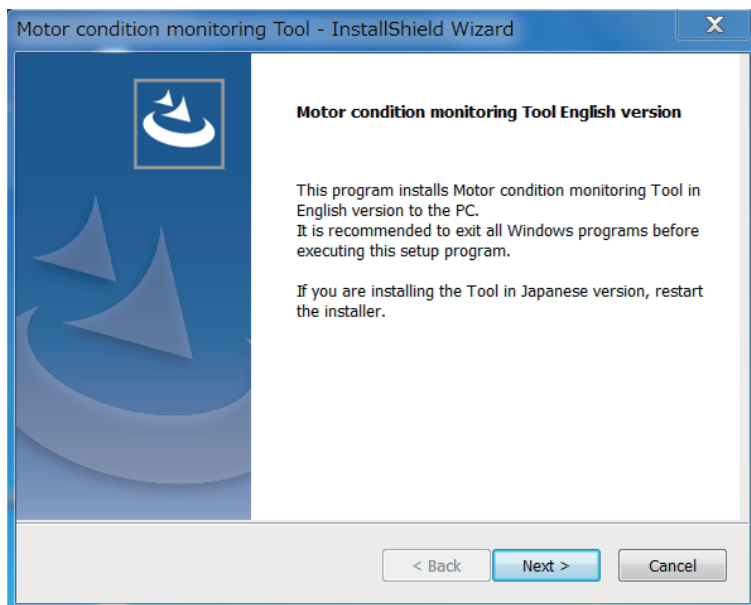

- 3** Click the [Next] Button.
The License Agreement Dialog Box appears.

- 4** Please read "License Agreement" carefully and check "I accept the terms of the license agreement" and click the [Next] Button if you can agree to all the terms. The [User Information] Dialog Box appears.
- 5** Click the "Install" Button. Installation of the software tool starts.
- 6** Install the Communications Middleware. Select the language to display in the installation. If an old version of the Communications Middleware is already installed, select whether to update Communications Middleware. If a new version of the Communications Middleware is already installed, go to step 15.
- 7** While the installation wizard is running, the [Windows Security] Dialog Box will be displayed. Click the [Install] Button.

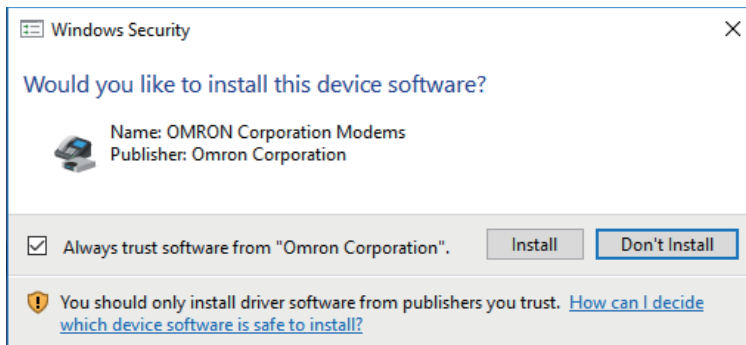

"OMRON Corporation Modems" is installed and the following [Windows Security] Dialog Box will be displayed.

- 8** Click the [Install] Button. "OMRON Corporation Ports (COM & LPT)" is installed.

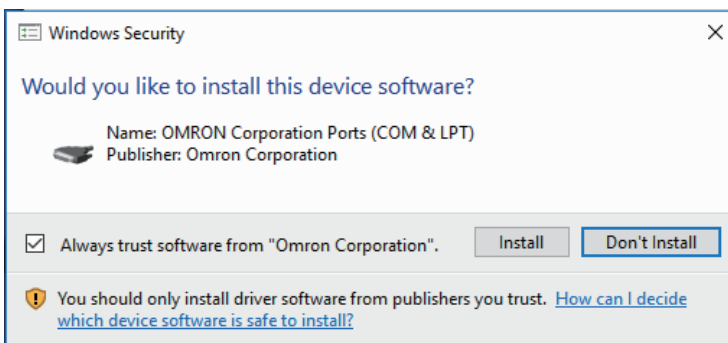

- 9** Since a dialog box prompting you to install WinPcap which is a component of Communications Middleware is displayed, click the [OK] Button. If WinPcap is already installed, go to step 15.

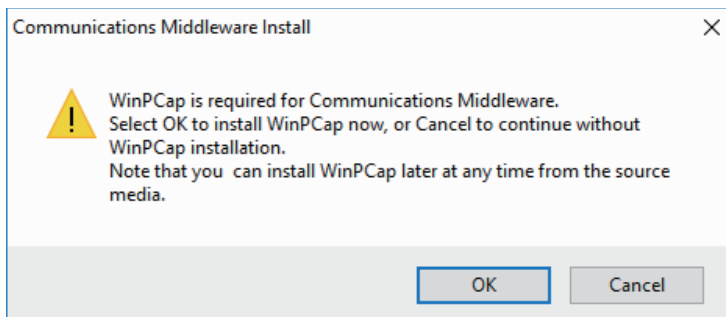

10 Click the [Next] Button.

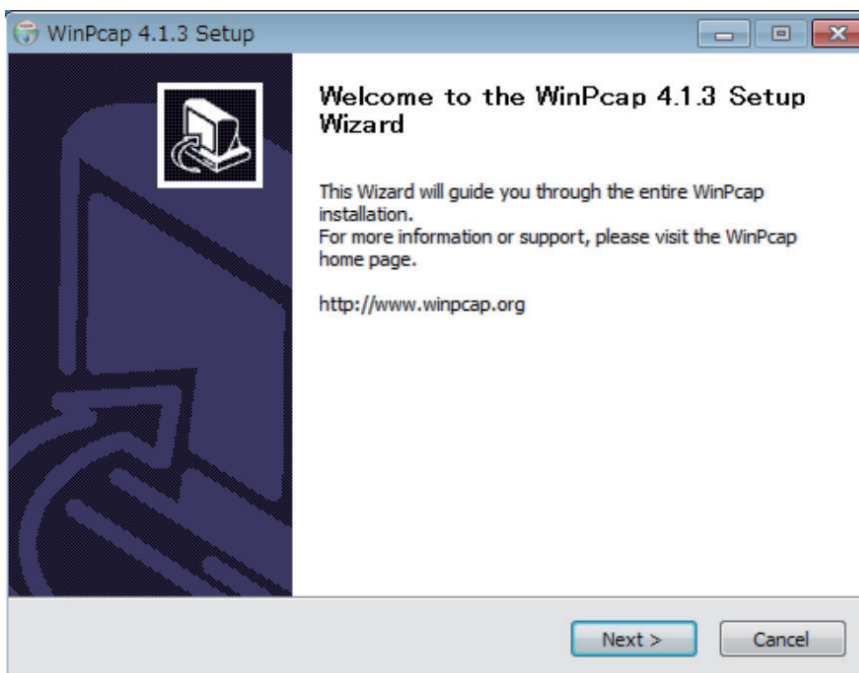

11 Click the [I Agree] Button.
The Installation options Dialog Box appears.

12 Check "Automatically start the WinPcap driver at boot time" and click the [Install] Button.
Installation of WinPcap will start.

13 Click the [Finish] Button.
Installation of WinPcap is completed.

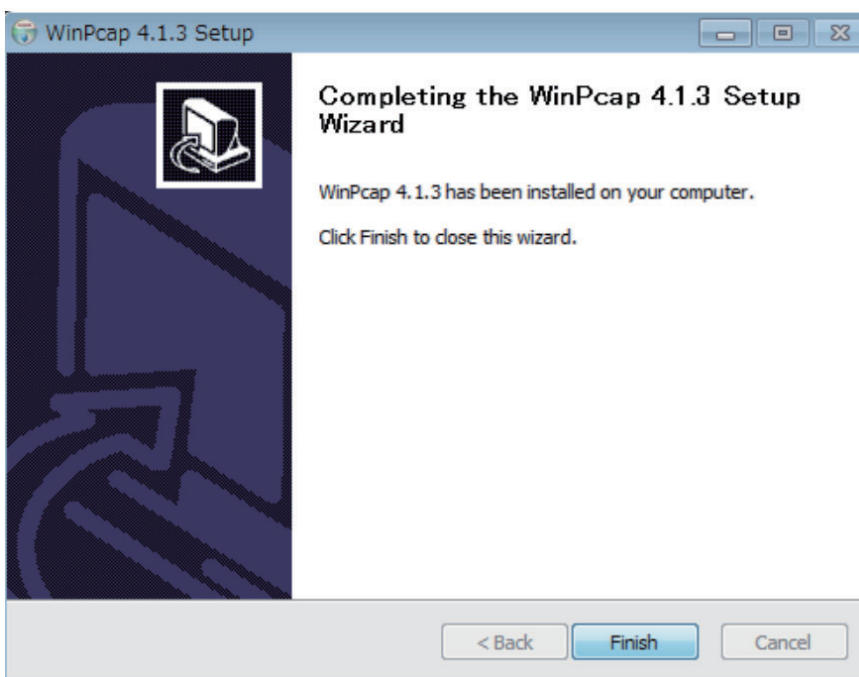

- 14** From the software tool, select the network card to be used for automatic connection to the K6CM device with the Ethernet cable from the pull-down list and click the [OK] Button. If Communications Middleware is already installed, go to step 15.

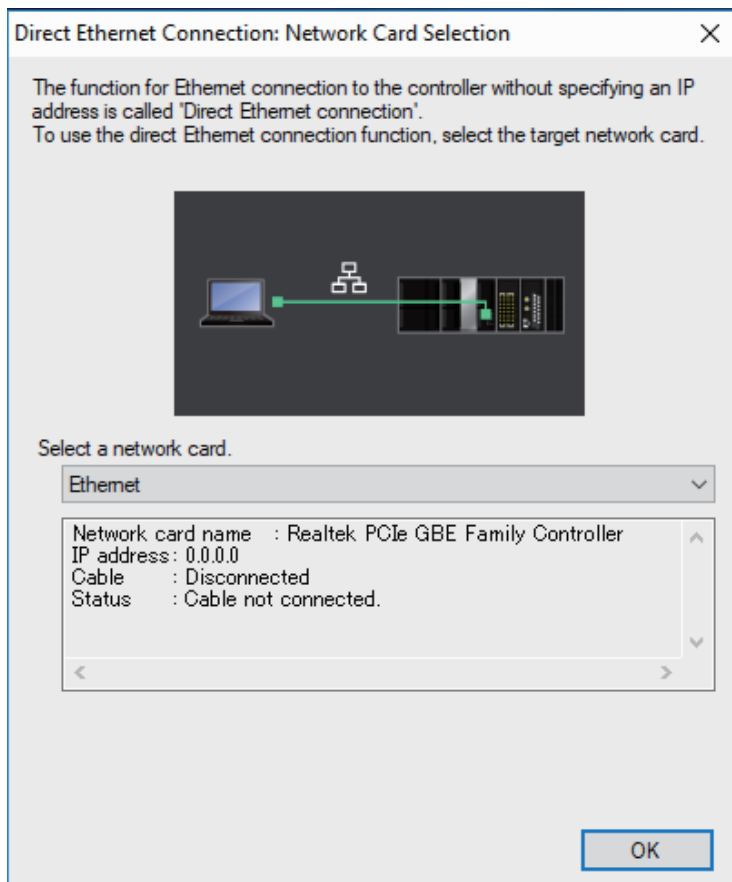

Network card configuration example

If there is only one wired LAN port of the computer and the Motor condition monitoring Tool communicates with the K6CM device with that wired LAN port, select the following.

(If the name of the network connection has been changed, select the one with the changed name.)

- Windows 7
Select "Local Area Connection".
- Windows 8.1/Windows 10
Select "Ethernet".

- 15** Select the computer restart and click the [Finish] Button. Remove the CD after rebooting.

4-2-2 Uninstallation Procedures

This section shows the procedure for uninstalling software tool.

- Windows 7

- 1** From the Start menu, select Control Panel | Add or Remove Programs. The Add or Remove Programs Dialog Box appears.
- 2** Select "Motor condition monitoring Tool" and click the [Delete] Button. A Dialog Box will be displayed confirming complete deletion of "Motor condition monitoring Tool".
- 3** Click the [Yes] Button. After completion, the Uninstall Complete Dialog Box will be displayed.
- 4** Click the [Finish] Button.

- Windows 8.1/Windows 10

- 1** From the [Start] menu, select [Control Panel] | [Uninstall a Program]. The [Uninstall/Change Program] Dialog Box will be displayed.
- 2** Select "Motor condition monitoring Tool" and click the [Delete] Button. A Dialog Box will be displayed confirming complete deletion of "Motor condition monitoring Tool".
- 3** Click the [Yes] Button. After completion, the Uninstall Complete Dialog Box will be displayed.
- 4** Click the [Finish] Button.

4-3 IP Address Setting

4-3-1 IP Address Setting of Your PC

Before starting this tool and monitoring and logging the K6CM device, it is necessary to set the IP address of the computer to the IP address of the same segment as the K6CM device. It shows the procedure.

Note that when setting only the K6CM device (IP address and other settings) with an automatic connection, it is not necessary to set the IP address on the computer side.

For the initial setting of K6CM, refer to "4-3-2 IP Address Setting of the K6CM Devices on page 4-26"

- Windows 7

- 1** Select [Start] | [Control Panel] | [Network and Sharing Center] | [Change Adapter Settings].
- 2** Right-click [Local Area Connection] and select [Properties].
- 3** Select [Internet Protocol Version 4 (TCP / IPv4)] and click [Properties].
Check "Use next IP address" and manually set IP address of the computer.

- Windows 8.1

- 1** Right-click [Start].
- 2** Select [Network connection].
- 3** Right-click [Ethernet], and click [Properties].
- 4** Select [Internet Protocol Version 4 (TCP / IPv4)] and click [Properties].
Check "Use next IP address" and manually set IP address of the computer.

- Windows 10

- 1** Click [Start] and select [Windows System Tools] | [Control Panel].
- 2** Select [Network and Sharing Center] | [Change adapter settings].
- 3** Right-click Ethernet and click Properties.
- 4** Select [Internet Protocol Version 4 (TCP/IPv4)] and click [Properties].
Check "Use next IP address" and manually set IP address of the computer.

● IP Address Settings Example

When using Ethernet for the first time, if you set the IP address and subnet mask of the computer and K6CM device as below, it is possible to connect the software tool to the K6CM device.

Device name	IP address	Sub-net mask	Default gateway
Computer	192.168.250.100	255.255.255.0	Blank
K6CM device 1st Unit	192.168.250.1	255.255.255.0	No change required (0.0.0.0)
K6CM device 2nd Unit	192.168.250.2	255.255.255.0	No change required (0.0.0.0)
K6CM device 3rd Unit	192.168.250.3	255.255.255.0	No change required (0.0.0.0)
⋮	⋮	⋮	⋮
K6CM device 30th Unit	192.168.250.30	255.255.255.0	No change required (0.0.0.0)

When the subnet mask is "255.255.255.0", the range of IP addresses that can be set for the device is 192.168.250.1 to 192.168.250.254. Assign IP address in this range to each K6CM device.

The same IP address can not be assigned to more than one device.

The default value of the IP address of type K6CM device is "192.168.250.10" common to all models.

With the subnet mask of all K6CM devices set to "255.255.255.0", Ethernet communications can be performed because devices are in the same network (i.e., segment), if an IP address is between 192.168.250.1 and 192.168.250.254.

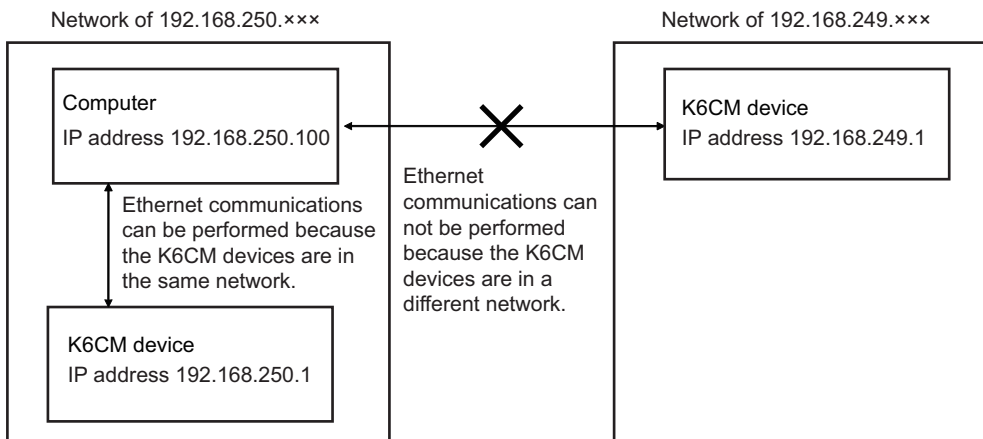

4-3-2 IP Address Setting of the K6CM Devices

There are two ways to connect the software tool to the K6CM.

- Automatic connection (direct one-to-one connection)
- Fixed IP Connection (connection via hub)

Automatic connection (direct one-to-one connection)

Directly connect the computer and each K6CM device via the Ethernet cable without going through the hub.

In the case of direct connection, there are the following merits:

- Can be connected without specifying IP address of K6CM device.

Either straight type or cross type Ethernet cable is available.

Note If the IP address setting method of the K6CM device is set to BOOTP, auto connection can not be made until connecting to the BOOTP server.

Create project

IP address setting

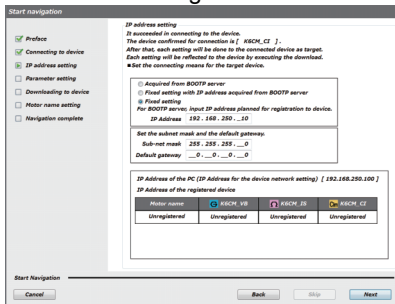

Parameter setting (as necessary)

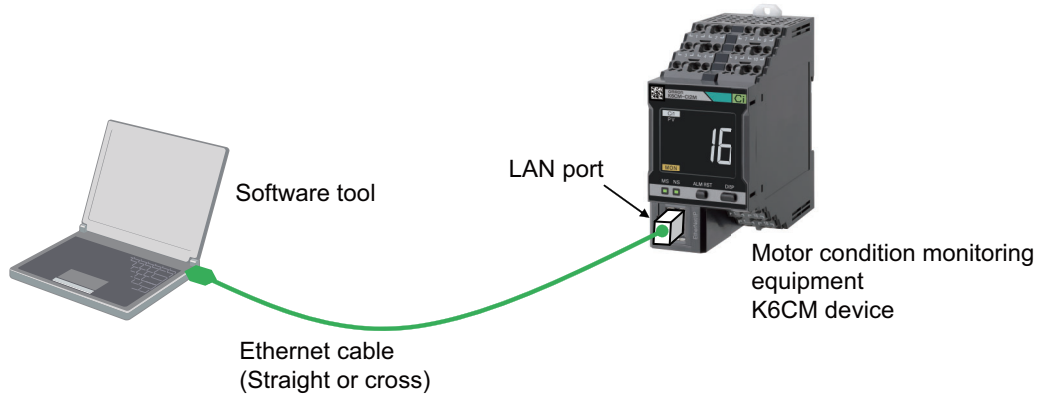
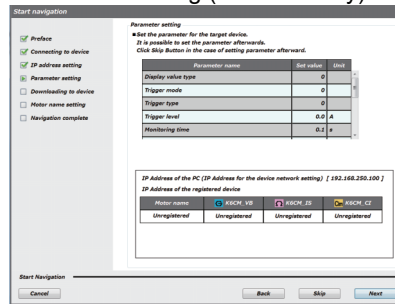

Fixed IP Connection (connection via hub)

Connect the computer and each K6CM device with an Ethernet cable via the hub.

In the case of fixed IP connection, there are the following merits.

Fixed IP Connection is a method to connect by specifying the IP address of the K6CM device you want to connect.

- Connectable with PC connected to multiple K6CM with Ethernet cable

Note Do not connect more than one K6CM device with the same IP address.
IP address may become duplicated and communications may fail.

Either straight type or cross type Ethernet cable is available.

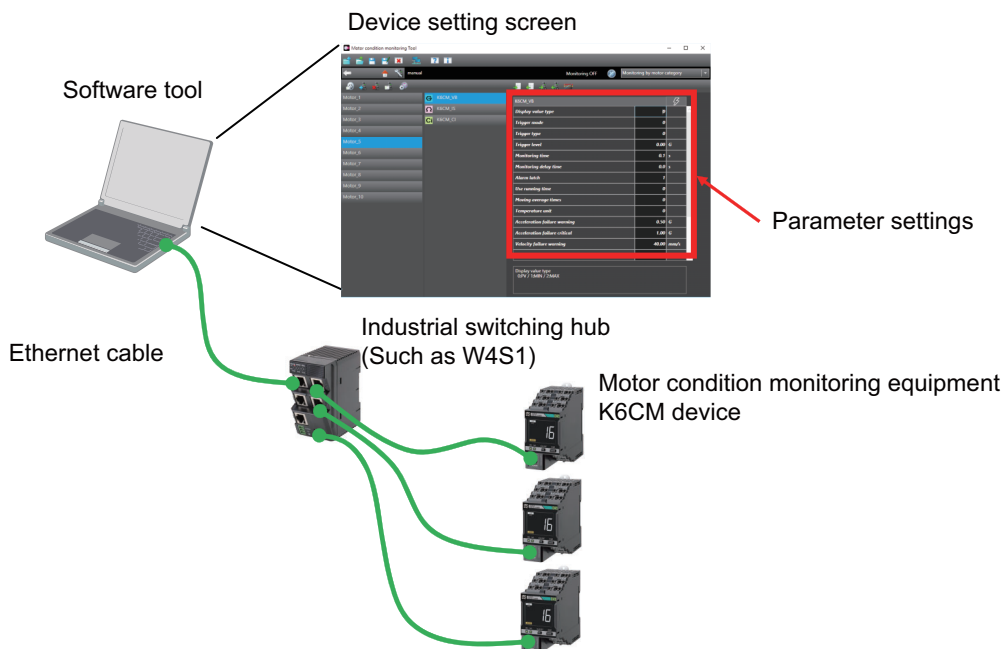

Procedure for Setting IP Address (when necessary, further parameters)

The IP address of each K6CM device is set by the following procedure. It is also possible to set further parameters when necessary.

The initial value of the IP address of the K6CM device is "192.168.250.10" common to all models.

- 1 Connect your PC directly to the K6CM device one-on-one using the Ethernet cable.
- 2 Start the Motor condition monitoring tool.
The following startup screen will be displayed.

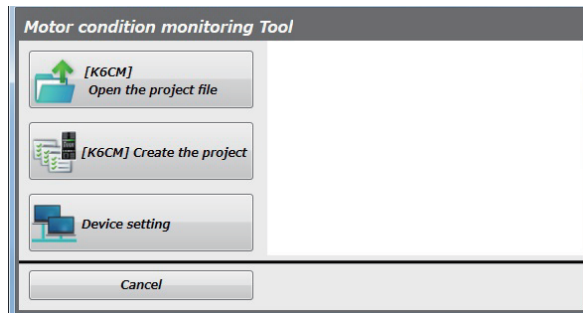

- 3 Select [Device setting].
The following SYSMAC Gateway Console screen is displayed.

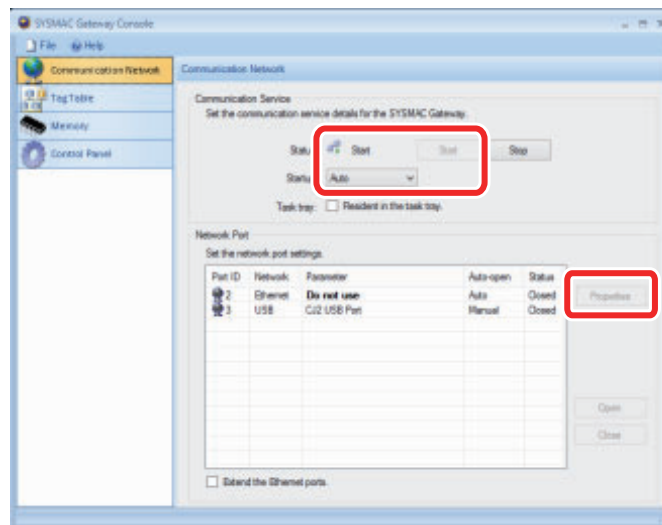

- (1) Confirm that [Startup] in the [Communication Service] field is "Auto" and that [Status] is "Start".

Note The communication service of SYSMAC Gateway is in the starting state at the same time that Windows starts, when [Startup] on the SYSMAC Gateway Console screen is "Auto".

- (2) Set the network port to which you want to connect in the [Network Port] field.

Note If you set multiple ports, the port with the smallest ID number in the [Port ID] column is automatically used.

For example, click the "Port ID 2", and then click the [Properties] Button, you will see the following [Port Properties] Dialog Box.

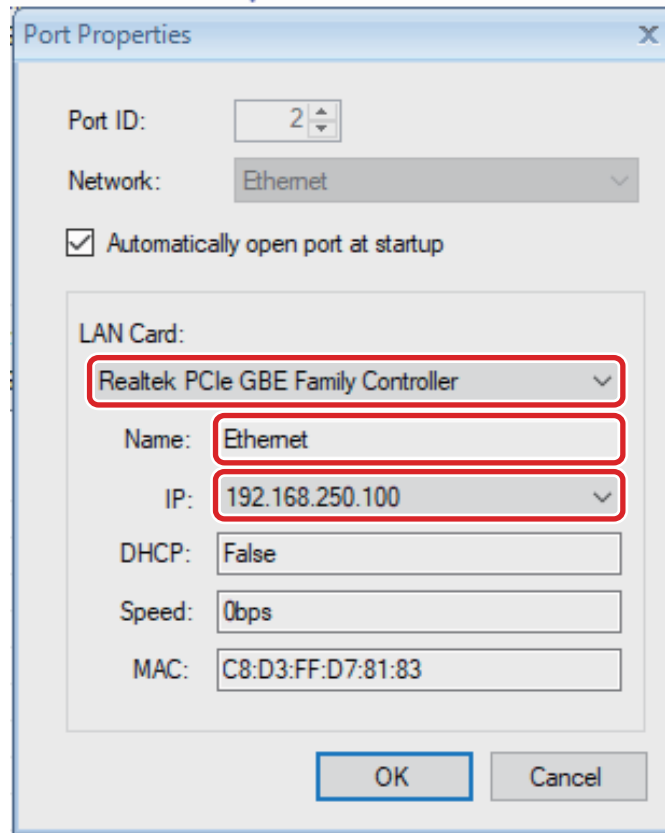

LAN card configuration example:

If there is only one wired LAN port of the computer and the Motor condition monitoring Tool communicates with the K6CM device with that wired LAN port, select the following.

(If the name of the network connection has been changed, select the one with the changed name.)

- Windows 7
Select a LAN card in the "Name" field is "Local Area Connection" is displayed.
- Windows 8.1/Windows 10
Select a LAN card that is displayed is "Ethernet" in the "Name" field.
When multiple ports are set, the port with the smallest ID number in the [Port ID] column is automatically used.



Precautions for Correct Use

Do not select AutoIP address (169.254.xxx.xxx: x is an arbitrary number).

If IP addresses other than the AutoIP address are not displayed, the IP address of the computer is not set.

Set the IP address of the computer before performing this procedure again in reference to "4-3-1 IP Address Setting of Your PC on page 4-24".

- 4** Select [[K6CM] Create project].
The following confirmation screen will be displayed.

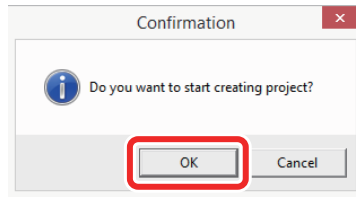

Precautions for Correct Use

Be sure to select [Device setting] before selecting [[K6CM] Create project].

If [[K6CM] Create project] is selected before selecting [Device setting], proceed to Step 6 and click the [Cancel] Button to close the screen. Click the [Cancel] Button and do not save the project, please exit. Then start the Motor condition monitoring Tool again.

- 5** Click the [OK] Button.
The following [Select the connecting method.] Dialog Box is displayed.

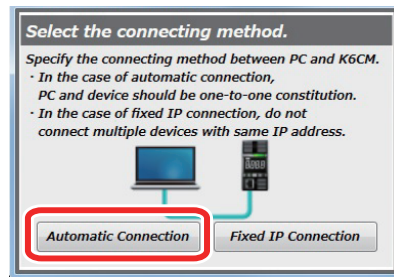

- [Automatic Connection] Button: Used to connect to the device without specifying the IP address of the connected device.
- Note
1. Directly connect the computer and devices one-on-one, and then click it.
 2. If the IP address setting method of the K6CM device is set to BOOTP, auto connection can not be made until connecting to the BOOTP server.
- [Fixed IP Connection] Button: Used to connect to the device with specifying the IP address of the connected device.

Note The Fixed IP connection Button can be used to connect devices when multiple devices are connected via a hub. However, do not connect devices with the same IP address. IP address may become duplicated and communications may fail.

- 6** Click the [Automatic Connection] Button.
The [Preface] wizard screen of the following [Start navigation] Dialog Box is displayed.

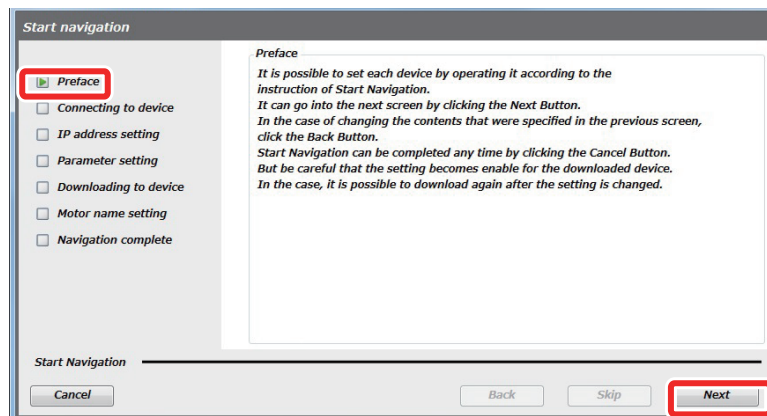

- 7 Click the [Next] Button.
The following [Connecting to device] wizard screen will be displayed.

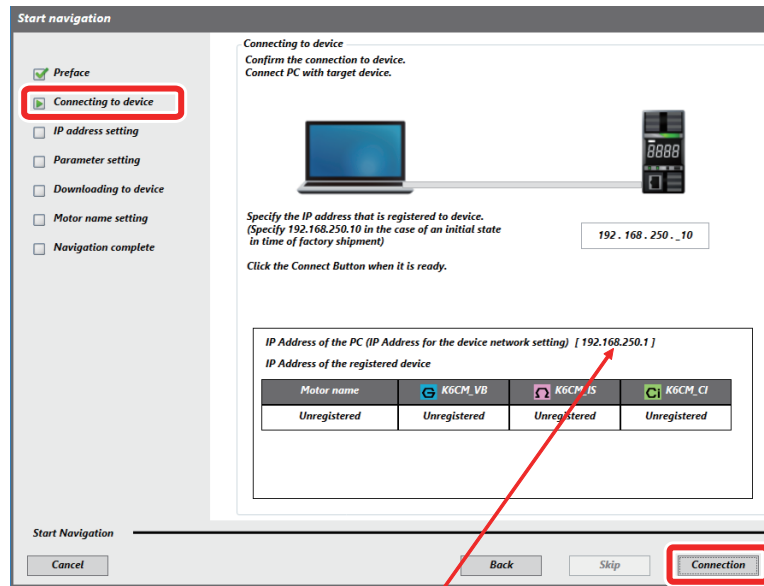

The IP address selected in the [Port Properties] Dialog Box is displayed on the screen displayed by selecting [Device setting] on the startup screen.

If IP address selection is incomplete (i.e., Network port parameter is "Do not use"), "0.0.0.0" is displayed. If "0.0.0.0" is displayed, you can connect to the device if you set the connection method to "Automatic Connection" in step 5, but if you set "Fixed IP connection" you cannot connect to the device.

Version Information

With software tool version 1.2.0.0 or later, the column for displaying the IP addresses of your PC and registered devices are displayed.

- 8 Click the [Connection] Button.
"Connecting" will be displayed on the line between the computer and the device on the following [Connecting to device] wizard screen.

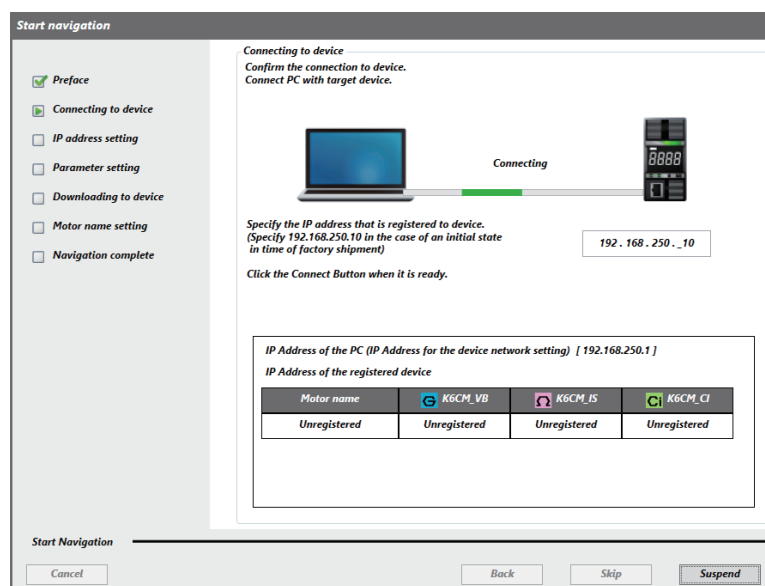

When the connection is successful, the following [IP address setting] wizard screen will be displayed.

Start navigation

- Preface
- Connecting to device
- IP Address setting**
- Parameter setting
- Downloading to device
- Motor name setting
- Navigation complete

IP Address setting
 It succeeded in connecting to the device.
 The device confirmed for connection is [K6CM_CI].
 After that, each setting will be done to the connected device as target.
 Each setting will be reflected to the device by executing the download.
 ■Set the connecting means for the target device.

Acquired from BOOTP server
 Fixed setting with IP address acquired from BOOTP server
 Fixed setting
 For BOOTP server, input IP address planned for registration to device.
 IP Address

Set the subnet mask and the default gateway.
 Sub-net mask
 Default gateway

IP Address of the PC (IP Address for the device network setting) [192.168.250.1]
 IP Address of the registered device

Motor name	K6CM_VB	K6CM_IS	K6CM_CI
Unregistered	Unregistered	Unregistered	Unregistered

Start Navigation



Additional Information

Click the [Suspend] Button to abort the connection.



Version Information

With software tool version 1.3.0.0 or later, a message appears to notify that processing will be in accordance with the connected device if the Eip cpu version of the connected device differs. For details on each version compatibility, refer to *A-11 Version Compatibility A-51* on page A-1.

9

In the "Set the connecting means for the target device.", set the following. Check one of the following check boxes.

- Acquired from BOOTP server
- Fixed setting with IP address acquired from BOOTP server
- Fixed setting

When "Fixed setting" is checked, set the IP address, subnet mask, default gateway.

Note When "Fixed setting with IP address acquired from BOOTP server" or "Acquired from BOOTP server" is checked, set the IP address to be acquired from the BOOTP server here.

If the device obtains a value different from that value from the BOOTP server, the Motor condition monitoring Tool will not be able to access that device. In that case, delete the relevant device with the [Delete device] Button of the tool buttons, and then re-register the device with the IP address obtained from the BOOTP server by the [Add device] Button.



Precautions for Correct Use

When setting the IP address of the K6CM to "Fixed setting", set the IP address of the computer to the IP address of the same segment as the K6CM. For details of the setting method, refer to *4-3-1 IP Address Setting of Your PC* on page 4-24.

10 Click the [Next] Button.
 The following [Parameter setting] wizard screen will be displayed. (Set the parameters as necessary.) For details, refer to “6-2-1 Settings for Each Monitor Type of K6CM devices on page 6-19”.

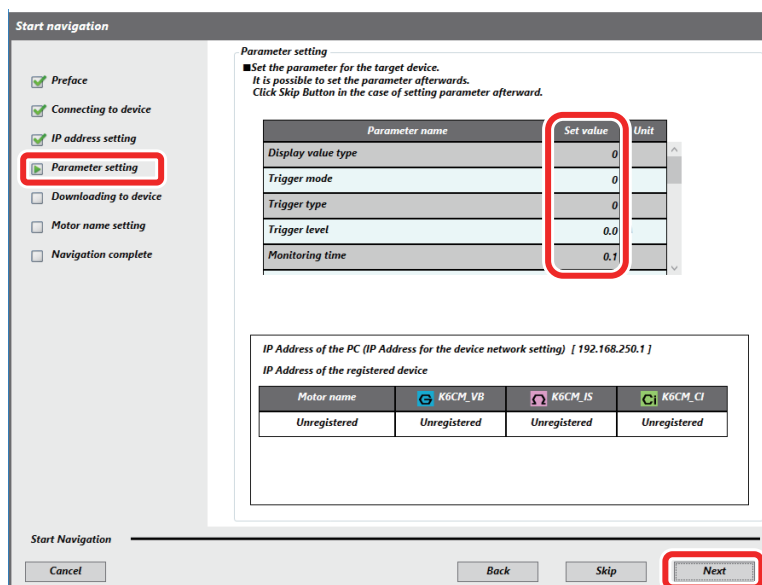

Be sure to set the parameters in the table below before starting measurement.

Model	Parameter name	Setting value
Comprehensive current diagnosis type	Current range	Input the set value according to special CT to be used. 0: Rated CT 5 A is connected (K6CM-CICB005) 1: Rated CT 25 A is connected (K6CM-CICB025) 2: Rated CT 100 A is connected (K6CM-CICB100) 3: Rated CT200 A is connected (K6CM-CICB200) 4: Rated CT 400 A is connected (K6CM-CICB400) 5: Rated CT 600 A is connected (K6CM-CICB600)
Vibration & temperature type	Temperature unit	Select the temperature unit of motor temperature and Temperature gap. 0: °C 1: °F
Insulation resistance type	Circuit topology	Input the set value according to the motor drive method. 0: Three-phase three-wire system, S-phase grounding 1: Three-phase four-wire system, N-phase grounding, delta connection load
	Using inverter	Input the set value according to the presence or absence of the inverter. 0: Without inverter 1: With inverter
	Inverter special measurement	Input the set value according to the inverter frequency 0: Set when inverter frequency is far from commercial frequency 1: Set when inverter frequency is close to commercial frequency

Version Information

With software tool version 1.3.0.0 or later, a parameter that is not supported by the connected device (depends on the Eip cpu version) cannot be selected (is grayed out).

11 If you do not want to set the parameters, click the [Skip] Button.
 The [Downloading to device] wizard screen of the following [Start navigation] Dialog Box is displayed.

- Note 1. If you click the [Skip] Button, the parameters will not be downloaded.
 If you set the parameters, click the [Next] Button. The [Downloading to device] wizard screen of the following [Start navigation] Dialog Box is displayed.
2. If you click the [Next] Button, the parameters will be downloaded.

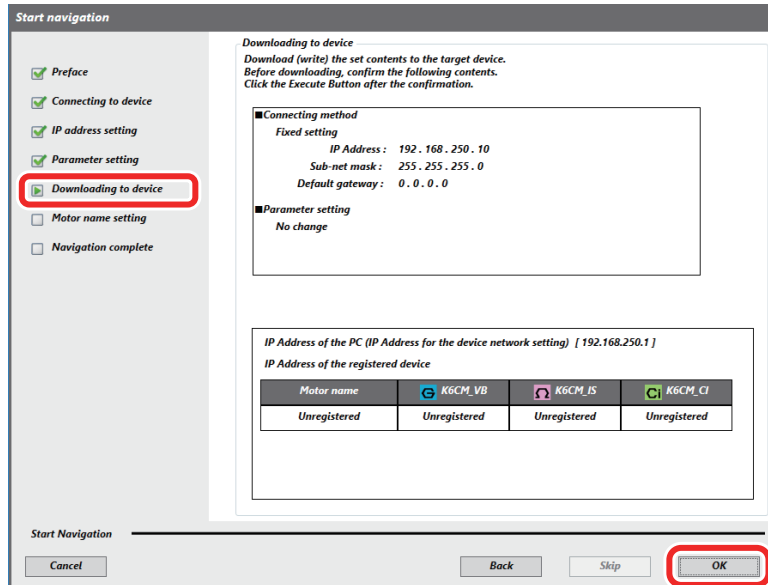

12 Click the [OK] Button.
 The following [Downloading to device] wizard screen will be displayed.
 When the download is successful, the following [Motor name setting] wizard screen will be displayed.

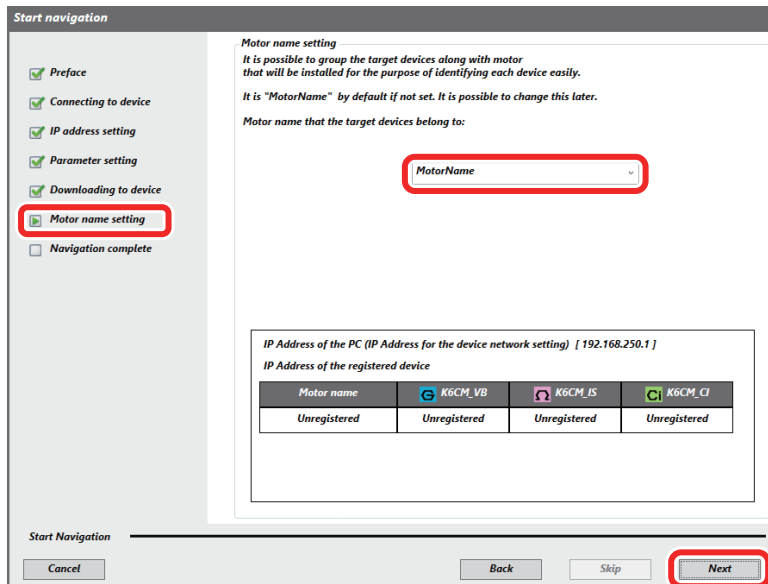

Note If the download fails, "Failed to download." is displayed on the "Downloading to device" wizard screen in the following [Start navigation] Dialog Box. After checking the connection, click the [OK] Button, or click the [Back] Button and go back to one of the steps from step 4.

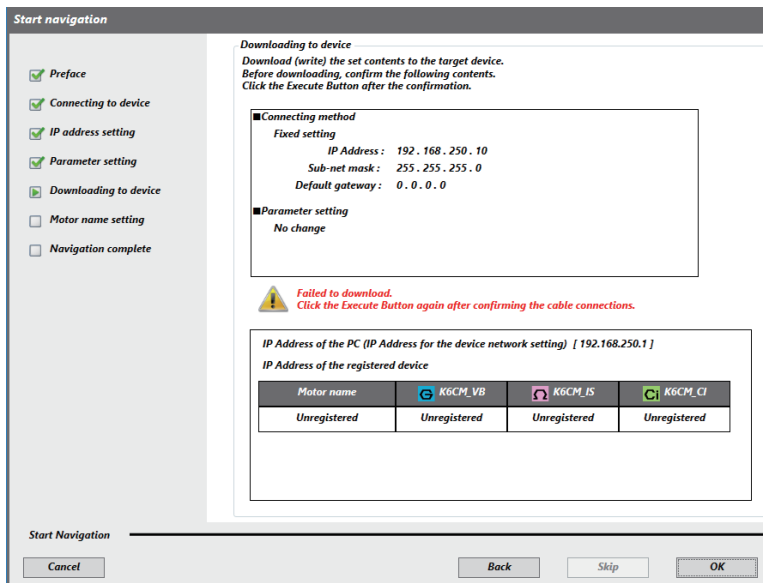

13 In the field of "Motor name that the target devices belong to", set the motor name to which the target device belongs. The initial value is MotorName.



Precautions for Correct Use

- It is not possible to register the same type of device in the same motor name.
- Up to 3 devices can be registered in the same motor name.

14 Click the [OK] Button. The following [Navigation complete] wizard screen is displayed.

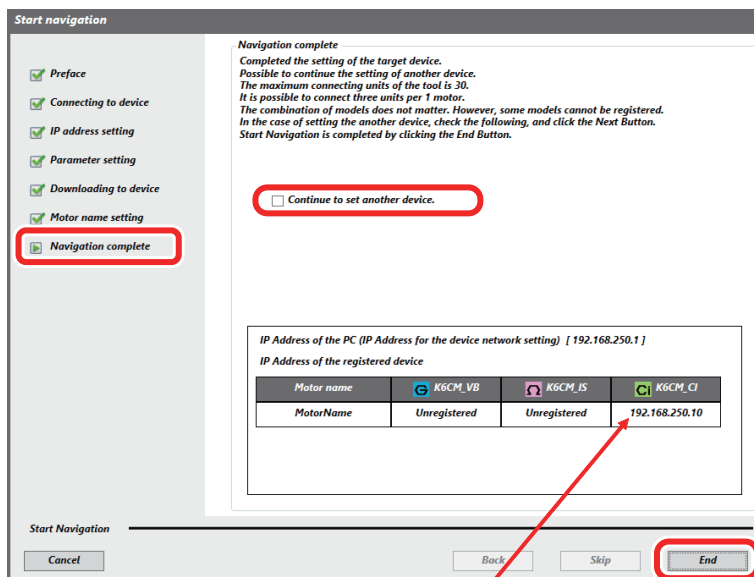

The IP address of the registered device is displayed.

● **Continue to configure other devices**

Turn ON the checkbox "Continue to set another device."

15 Click the [End] Button.

[Connecting to device] wizard screen of the following [Start navigation] Dialog Box is displayed as in step 5.

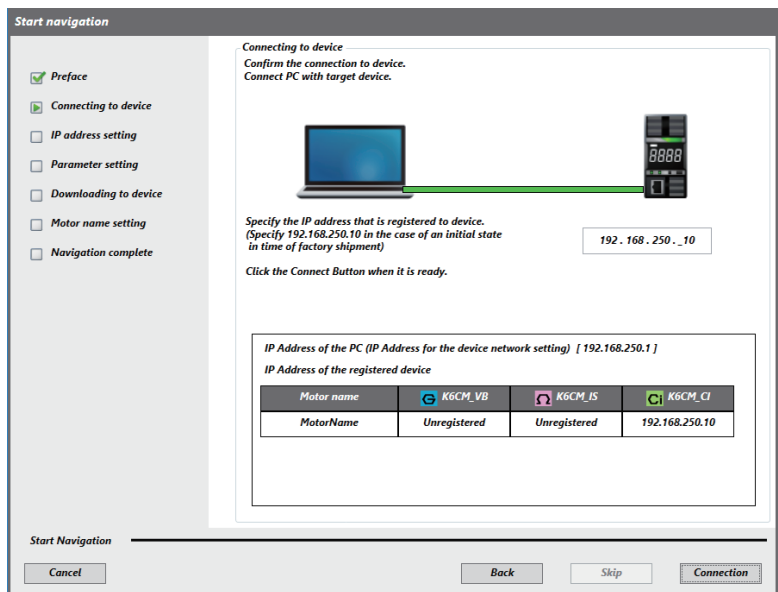

16 Connect the Motor condition monitoring Tool directly to the other form K6CM one to one.



17 Perform the same operation as Step 8 and the following.

- **When not setting other devices**

Turn OFF the check of "Continue to set another device."

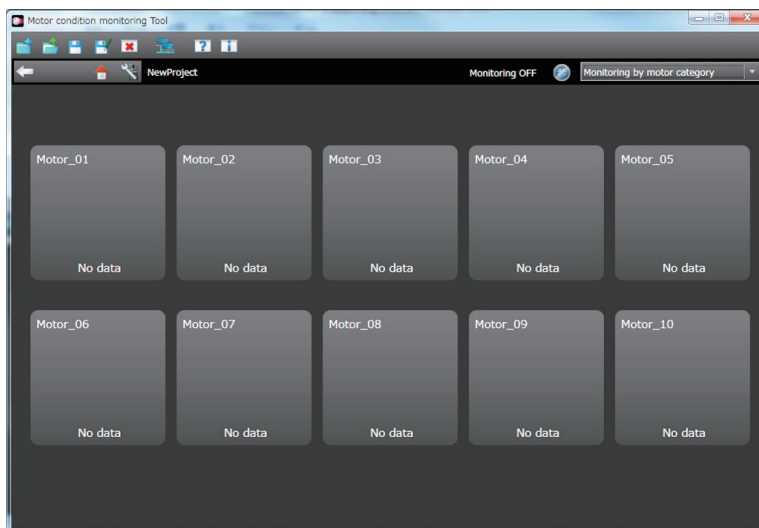
- 15** Click the [End] Button. The monitor screen shown below is displayed for each motor unit. The motor name will be displayed in the registered order.



- 16**  [Save the project file] or  [Save the project as the specified name] Button. The following Save Destination dialog box will be displayed.

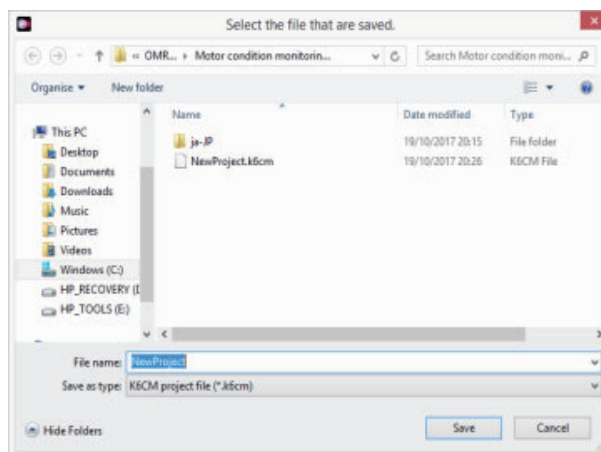

- 17** Enter the directory and project name and click the [Save] Button. The following dialog box will be displayed.

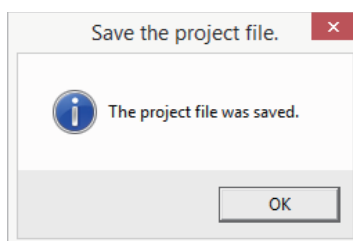





- 18** Click the [OK] Button.

When confirming the IP address of the registered device

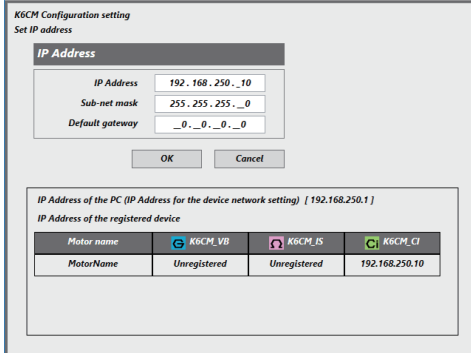
If you want to check the IP address of the device registered on the project, perform the following operations.

- 1 Select the device you want to change and click the  [Device setting] Button on the setting screen tool button.
The following [K6CM Configuration setting] Dialog Box is displayed.



Motor name	 K6CM_VB	 K6CM_IS	 K6CM_CI
MotorName	Unregistered	Unregistered	192.168.250.10

Note The IP address displayed here is the value registered in the project.

Version Information

With software tool version 1.2.0.0 or later, the column for displaying the IP addresses of your PC and registered devices are displayed.

When changing the IP address of the device

When changing the IP address of the device

- 1 Select the device you want to change and click the  [Device setting] Button on the setting screen tool button.
The following [K6CM Configuration setting] Dialog Box is displayed.

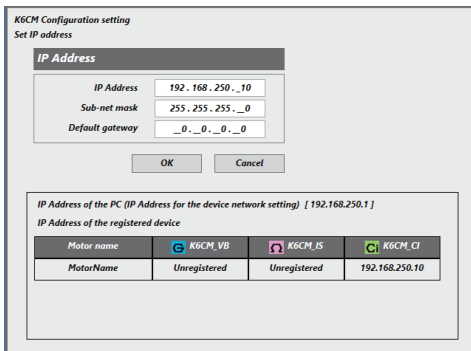

- 2 Change the IP address. Change the subnet mask and default gateway as necessary.

- 3 Click the [OK] Button.

The IP address setting on the project is changed, and at the same time, the IP address of the actual device at the communications destination is automatically changed.

Version Information

With software tool version 1.2.0.0 or later, the column for displaying the IP addresses of your PC and registered devices are displayed.

5

Installation and Wiring

This section describes the installation and wiring of the K6CM devices.

5-1	Dimensions	5-2
5-1-1	K6CM device	5-2
5-1-2	Special CT	5-2
5-1-3	Vibration & temperature Sensor	5-3
5-1-4	Insulation resistance sensor (special ZCT (IRT))	5-4
5-2	Installation	5-5
5-2-1	Precautions at installation	5-5
5-2-2	Installing the K6CM Device	5-5
5-2-3	Installation of the Vibration & Temperature sensor	5-7
5-2-4	Installation of the insulation resistance sensor (special ZCT (IRT))	5-13
5-2-5	Installation of the special CT	5-15
5-3	How to Connect to the Vibration & Temperature Sensor	5-16
5-3-1	When Connecting Directly to the K6CM Device	5-16
5-3-2	When Connecting by Extending the Cable	5-17
5-3-3	Recommended Ferrules and Crimp Tool	5-18
5-4	How to Connect to the Push-In Plus Terminal Blocks	5-19
5-4-1	the Push-In Plus Terminal Block	5-20
5-4-2	How to use the Push-In Plus Terminal Block	5-20
5-4-3	Recommended Ferrules and Crimp Tools	5-22
5-5	Diagram of Terminal Description	5-24
5-6	I/O wiring	5-25
5-7	Network Wiring	5-29

5-1 Dimensions

This section shows the external dimensions of the K6CM device and the sensors used.

5-1-1 K6CM device

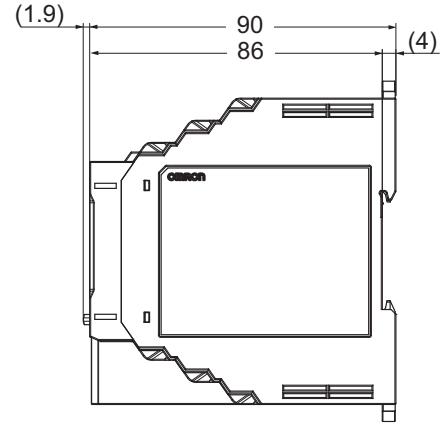
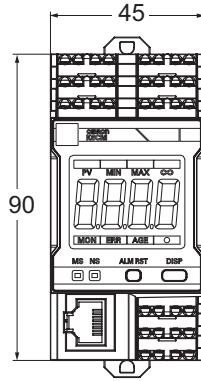

5-1-2 Special CT

K6CM-CICB005

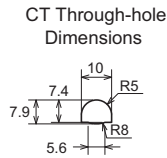
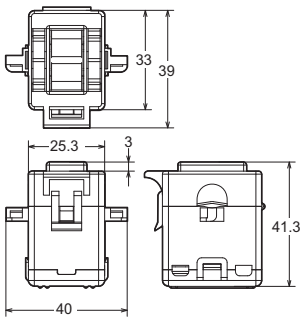

K6CM-CICB025

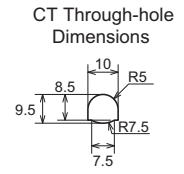
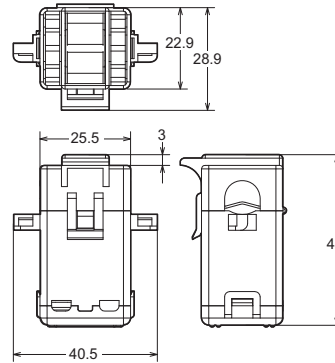

K6CM-CICB100

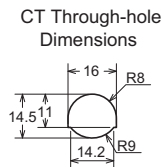
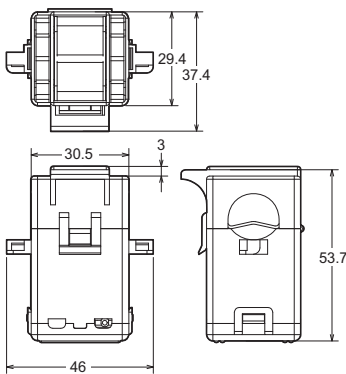

K6CM-CICB200

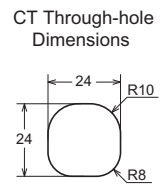
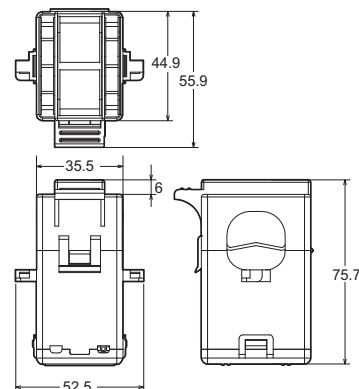

K6CM-CICB400
K6CM-CICB600

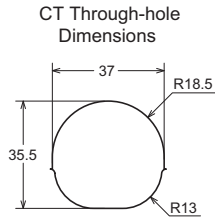
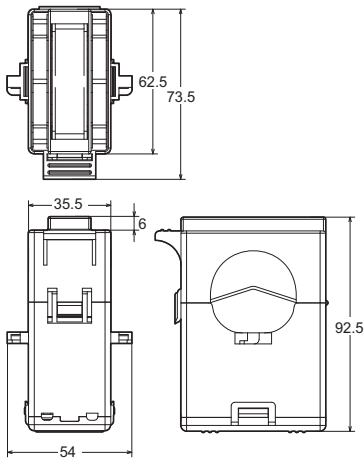

Cable supplied with CT

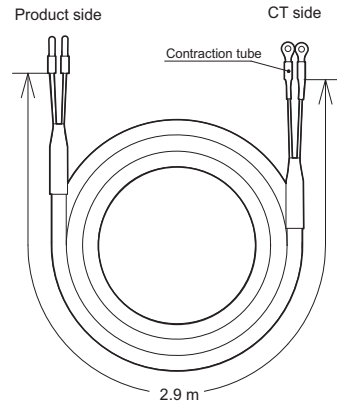

Note. CT supplied cable is attached to the CT.

5-1 Dimensions

5

5-1-3 Vibration & temperature Sensor

5-1-3 Vibration & temperature Sensor

Pre-amplifier

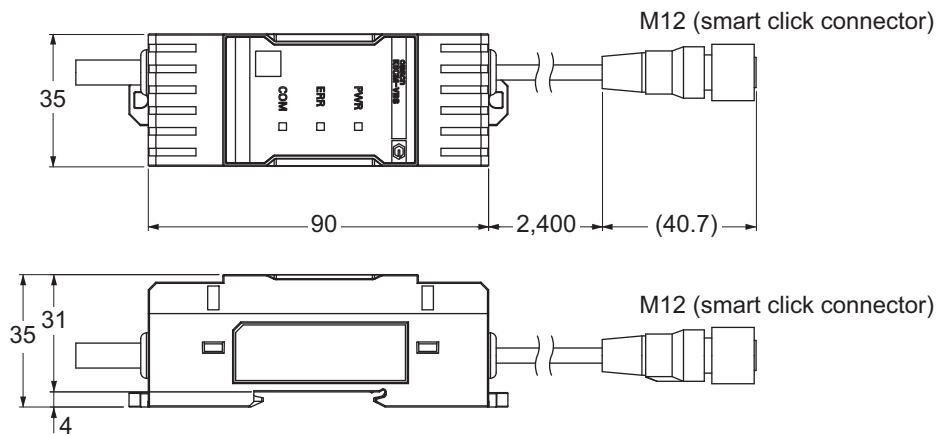

Sensor head

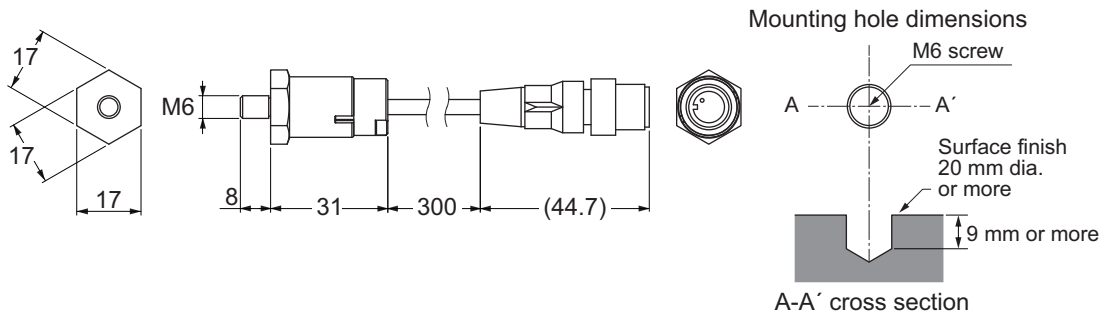

Adhesive Attachment

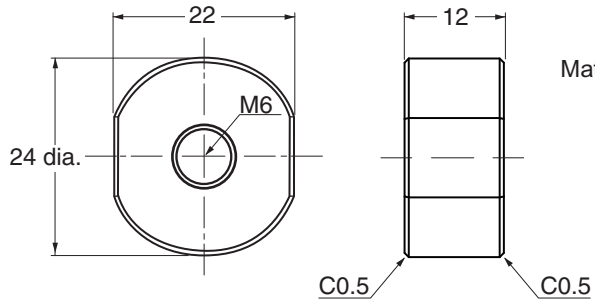
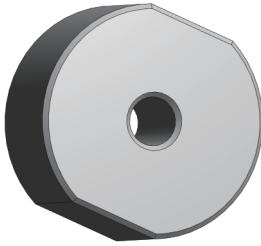

5-1-4 Insulation resistance sensor (special ZCT (IRT))

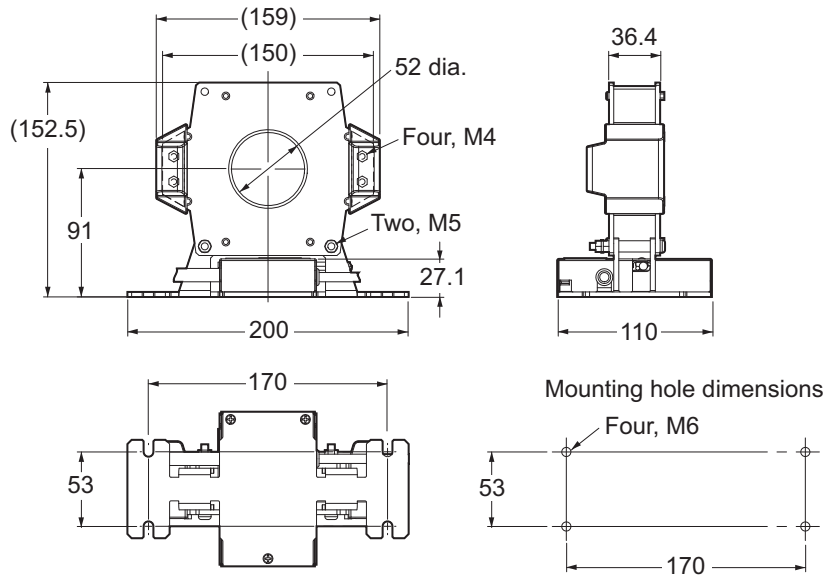
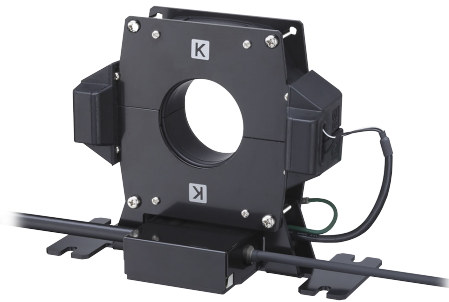

5-2 Installation

This section describes the installation of the K6CM devices.

5-2-1 Precautions at installation

Refer to the *Precautions for Safe Use* on page 7.

5-2-2 Installing the K6CM Device

For installation of the K6CM device, it is possible to install it on the DIN rail or install it with screws on the wall.

When installing on DIN Track

Screw the DIN Track in three or more places in a control cabinet.

- Recommended DIN Track

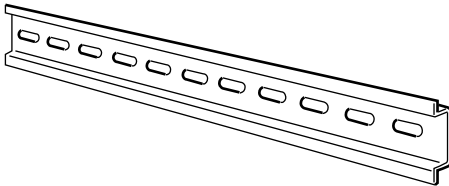

Model	Dimensions	Manufacturer
PFP-100N	1,000 mm	OMRON
PFP-50N	500 mm	

- PFP-M End plate (2 pieces)

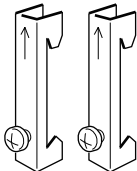

- Installation Direction

There is no particular restriction on the mounting direction of the K6CM device, but install it securely in the horizontal or vertical direction as much as possible.

● **How to install the K6CM device**

To mount the K6CM device to a DIN Track, hook the device onto the DIN Track and press the device in the direction of the arrow until you hear it lock into place.

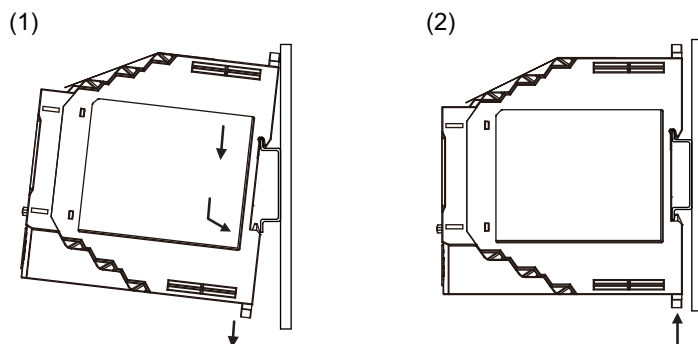

● **How to remove the K6CM device**

Pull down on the bottom hook with a flat-blade screwdriver and lift up on the product.

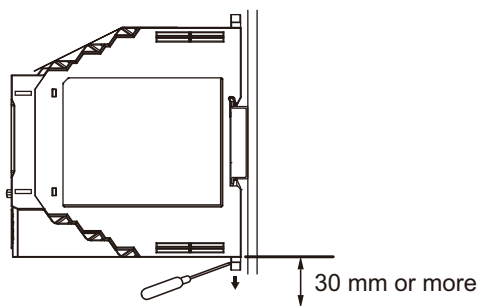

Leave at least 30 mm of space between the K6CM device and other devices to allow easy installation and removal.

Screw Mounting

(1) Pull out 2 hooks in the K6CM device back outside until sound will be.

(2) Insert M3 screw in a hole of a hook and fix.

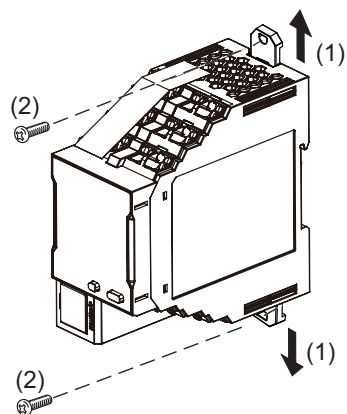

Mounting Hole Dimensions

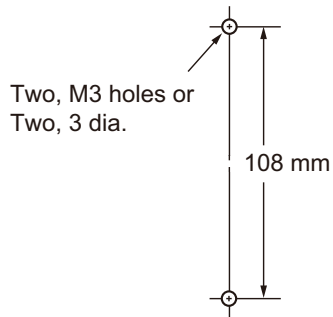

Note 1. Pull out the hooks to mount the K6CM device with screws.

2. Recommended tightening torque is 0.5 to 0.6 N·m.

3. Group mounting is not possible in the vertical direction.

5-2-3 Installation of the Vibration & Temperature sensor

The pre-amplifier used for Vibration & temperature type (K6CM-VB) can be mounted on a DIN rail or mounted on a wall with an M3 screw.

The mounting method is the same as K6CM device.

Vibration & temperature sensor
pre-amplifier
K6CM-VBS1

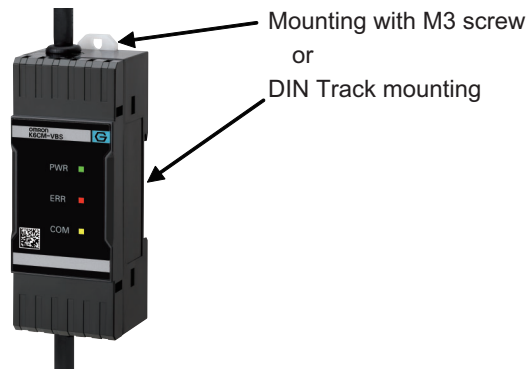

Installation of the Vibration Sensor Head

The vibration sensor head for Vibration & temperature type (K6CM-VB) should be mounted to the motor to be monitored.

The pre-amplifier and the sensor head are removable, as they are connected with the Smartclick Connector. Install the sensor head on the motor after it has been removed from the pre-amplifier.

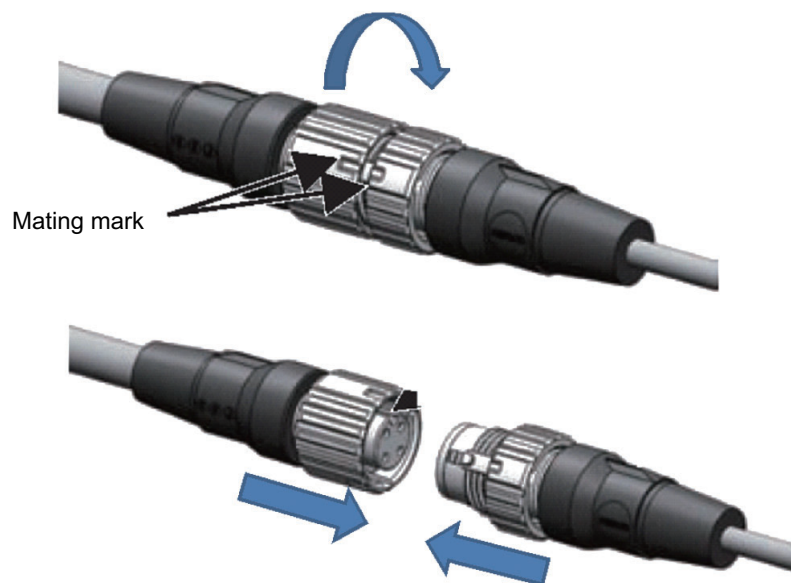

Mounting Vibration Sensor Head Easily

For the K6CM-VBS1 (M6 × 8 mm), a magnet for easy-mounting of the sensor is included.

The easy-mounting magnet is used for positioning of measuring place. Note that measurement accuracy is not guaranteed in the case of magnet mounting.

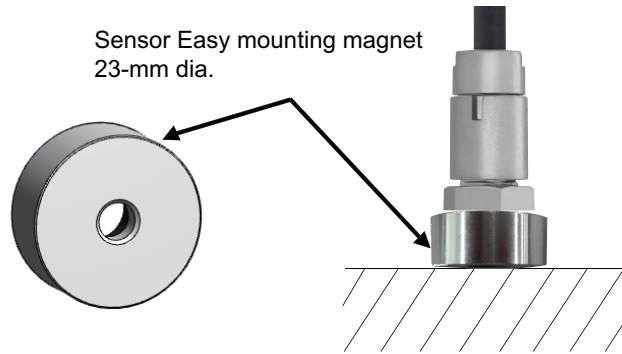

Note: The Sensor Easy mounting magnet is similar in shape to an adhesive attachment. Be careful not to handle it by mistake.

The connection between the pre-amplifier and the sensor head is a connector connection.

Fixing the Vibration Sensor Head

Mount the sensor head on the shaft side exterior of the induction motor.

Mount the vibration sensor head vertically to the upper shaft side of the motor

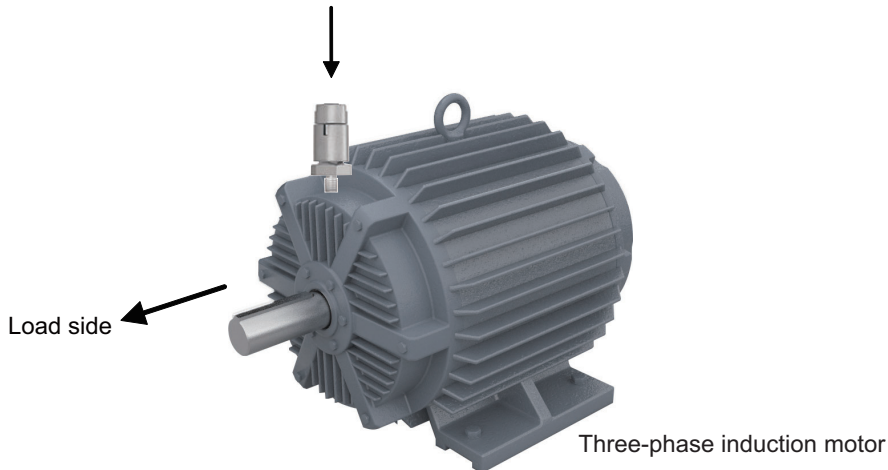

There are two ways to mount the vibration sensor head to the motor.

Method	Description
Method 1: Screw Mounting (recommended)	At the top of the armor of the motor, cut the tap into which the M6 screw vertically enters, and screw the vibration sensor head into it.
Method 2: Adhesive Mounting (*1)	Secure the attachment which is sold separately to the exterior of the motor using adhesive. Screw the vibration sensor head into the fixed attachment.

*1. K6CM will not conform to safety standards if attaching the vibration sensor with adhesive. In the case of disconnection, take safety measures such as fixing the cables.

We recommend Method 1 with a good absolute accuracy. However, if you cannot tap the motor, use Method 2.

The measurement error when measuring with Method 1 or Method 2 is as follows.

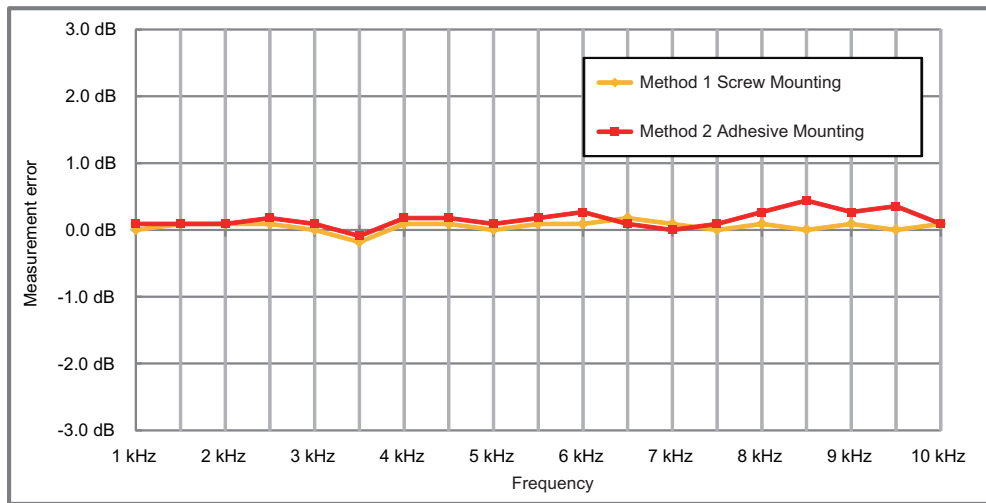

Note The above is reference test data, and it is not guaranteed.

● Fixing Vibration Sensor Head Using Screws

- 1 Turn the screw vertically to the upper side of the shaft side exterior of the induction motor, and mount the sensor head.

In general, bearings on the load side tend to malfunction, it is recommended to install it on the load side bearing position.

On the upper side of the shaft side of the motor, create a plane of 20 mm or more and tap off.

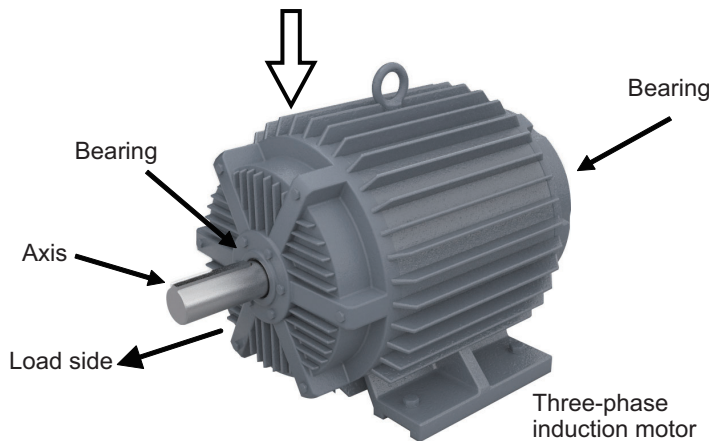

Mounting holes should be drilled with M6 depth of 9 mm or more.

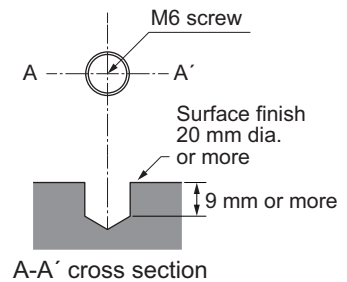

- 2 Mount the tip of the vibration sensor head to the screw hole. (Recommended tightening torque is 4.4 to 5.4 N•m)

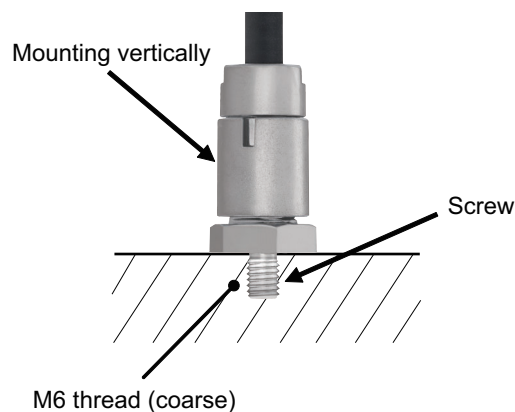

- 3 Install the sensor head to the motor, and then connect to the pre-amplifier.

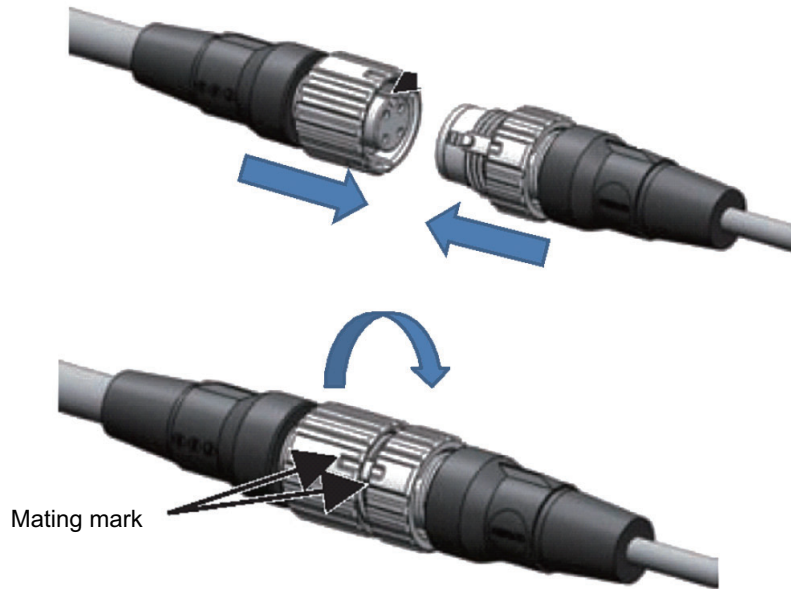

● **Fixing the Vibration Sensor Head Using Adhesive**

- 1 Make a flat surface of $\phi 25$ mm or more on the motor.

In general, bearings on the load side tend to malfunction, it is recommended to install it on the load side bearing position.

Make a flat surface of $\phi 25$ mm or more on the shaft side upper part of the motor.

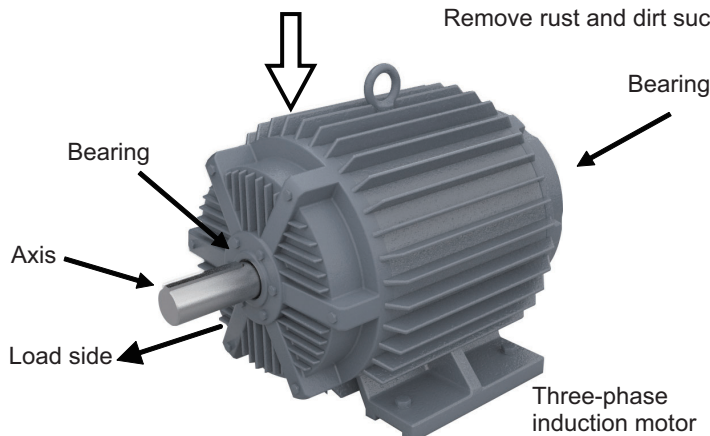

- 2 Apply the adhesive thinly and evenly to both the adhesive attachment and the motor's flat surface.

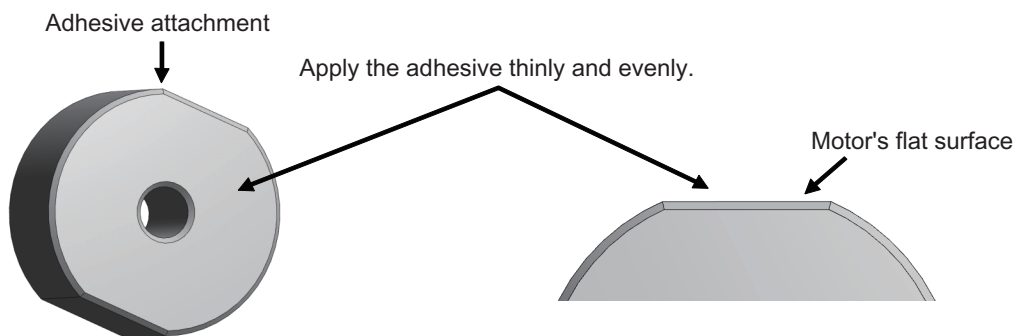

Note The adhesive attachment is similar in shape to an easy-mounting magnet. Be careful not to handle it by mistake.

Recommended adhesive is Super XG NO. 777 made by Cemedine Co., Ltd.

We evaluate with this recommended adhesive.

Super XG NO. 777 is a one-pack elastic adhesive based on acrylic modified silicone resin.

- 3** After waiting for 1 minute, paste the adhesive attachment with the motor's flat surface.

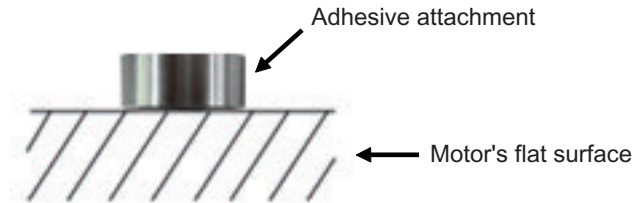

- 4** Dry for 24 hours, mount the tip of the vibration sensor head to the screw hole. (Recommended tightening torque 4.4 to 5.4 N•m).

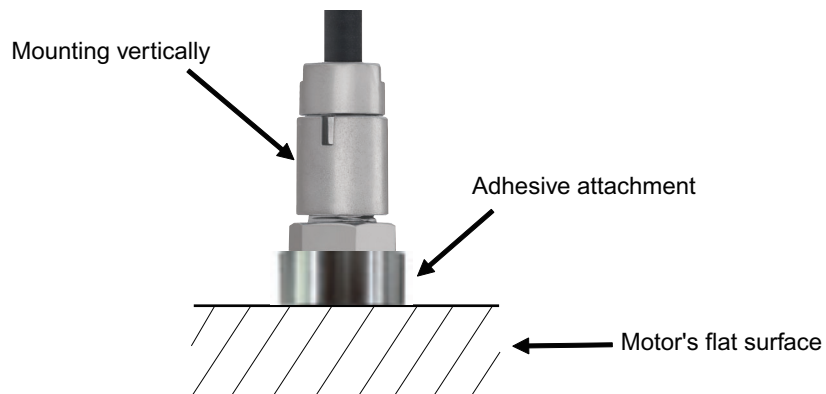

Procedures 2 to 4 are mounting methods when the recommended adhesive is used.

- 5** Connect the sensor head to the pre-amplifier before mounting it to the motor.

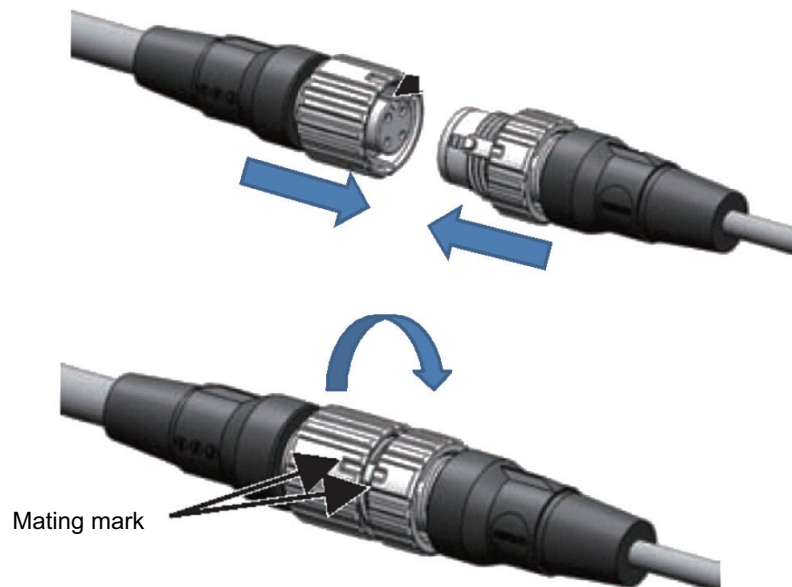



Precautions for Correct Use

The sensor head and the pre-amplifier are calibrated and inspected as a set at the factory shipment. Be sure to use them with the combination shipped. The sensor head cannot be replaced.

To verify the combination, check the serial numbers on the label of the sensor head and the label of the pre-amplifier. The same serial number means the correct combination.

If you change the combination of factory shipping conditions and then use them, the value of acceleration and the value of velocity will be inconsistent, so measurement cannot be correctly monitored.

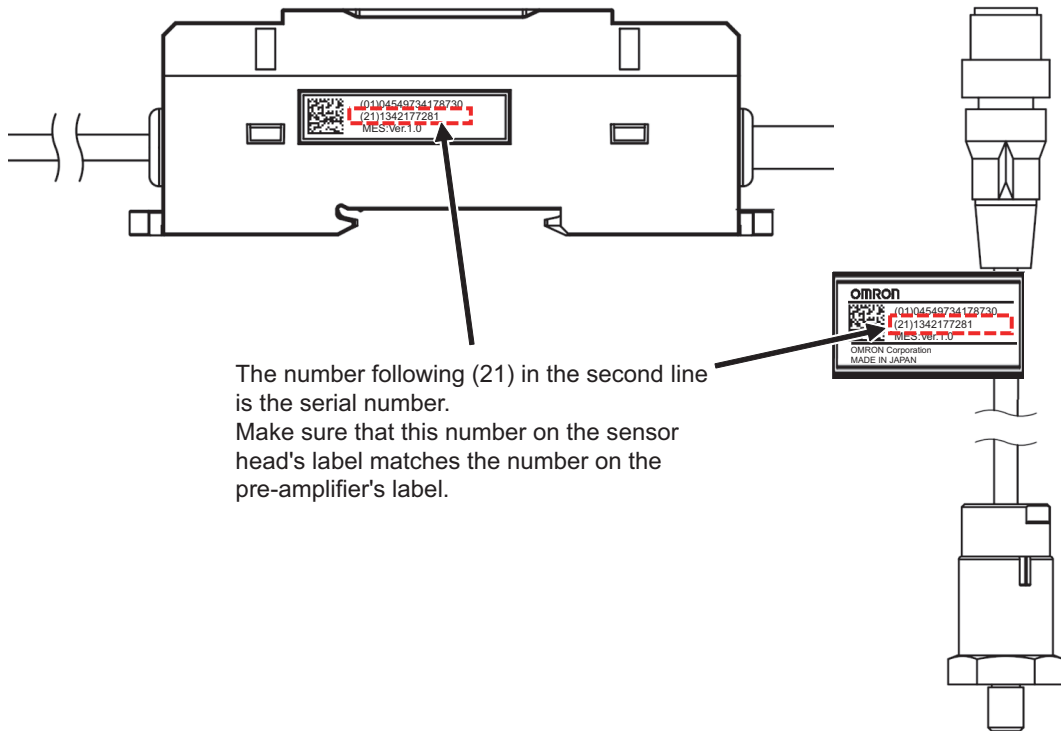

5-2-4 Installation of the insulation resistance sensor (special ZCT (IRT))

Insulation resistance sensor (special ZCT (IRT)) used for Insulation resistance type (K6CM-IS) is fixed on the wall etc and used.



Precautions for Correct Use

Insulation resistance sensor (special ZCT (IRT)) must be installed inside the cabinet.

Fastening of the Insulation resistance sensor (special ZCT (IRT))

Secure the special ZCT (IRT) to the wall with screws.

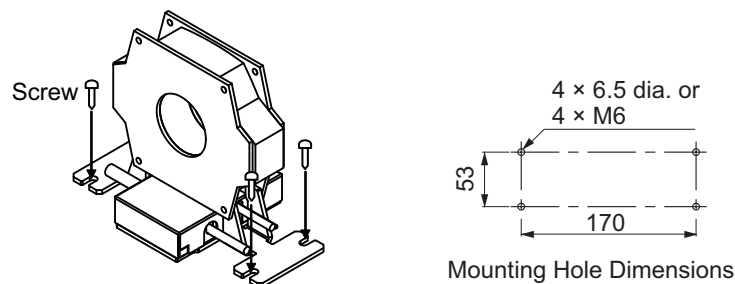

Precautions for Correct Use

If it is used without fixing, the cable may become overloaded and the cable may be disconnected.

Use special ZCT (IRT) in the cabinet. (If you use it outside the panel, the error may increase due to the influence of noise.)

Since the measurement accuracy deteriorates due to the influence of the external magnetic field, install special ZCT (IRT) more than 40 cm from the electric wire through which the large current flows. (It is a standard of 40 cm at 100 A, 10 cm at 40 A.)

Connection of Voltage Input Line

Connect the voltage input line of special ZCT (IRT) in parallel with the power line.

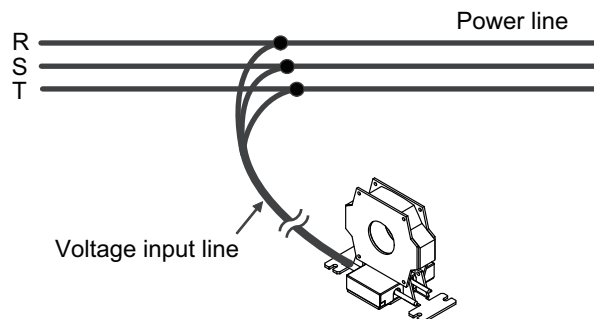

Precautions for Correct Use

Make sure that the wiring of the voltage input line of special ZCT (IRT) is made sure that the system voltage is not energized.

Connect the special ZCT (IRT) to the Power Line of the Three-phase Power Supply

Clamp to power line of three-phase power supply to diagnose special ZCT (IRT).

When using an inverter, clamp it to the secondary side of the inverter.

Special ZCT (IRT) can be divided by removing screws at both ends.

When disassembling the special ZCT (IRT), disconnect the signal line connected to the L terminal as shown in the diagram below.

After assembling the special ZCT (IRT), connect the signal line to the L terminal again. (Tightening torque is $0.75 \pm 0.15 \text{ N}\cdot\text{m}$.)

Be careful not to mistake the direction of L (load side) and K (power supply side) in the through hole.

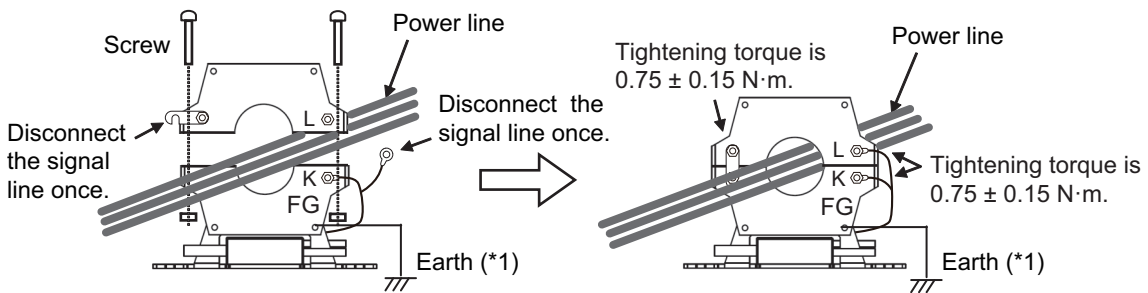

*1 According to IEC 60364 TT method.



Precautions for Correct Use

Do not ground the K and L terminals in special ZCT (IRT). It is already connected to FG in the internal circuit.

Ground the FG terminal of special ZCT (IRT). If you do not ground it, the measurement accuracy will be worse.

Special ZCT (IRT) Wiring Diagram

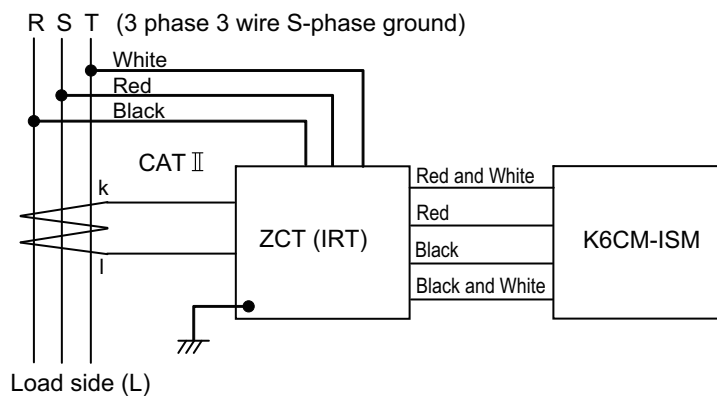

5-2-5 Installation of the special CT

Special CT for Comprehensive current diagnosis type (K6CM-CI2) must be used always with the special CT supplied cable.

Note Do not extend the special CT supplied cable. An extended cable for it does not satisfy the safety standards.

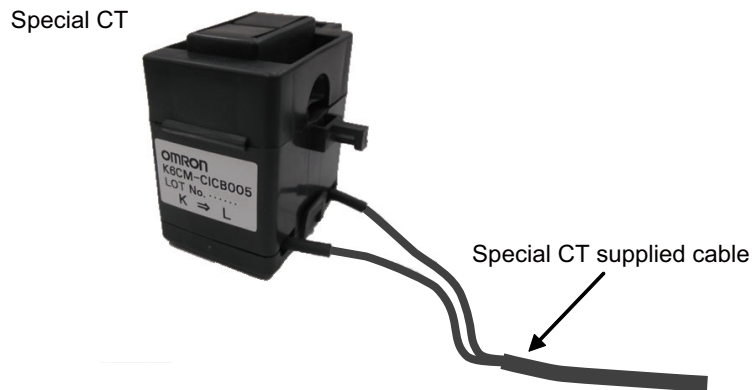

Connect a special CT to the power line

Clamp the special CT to the power line to be diagnosed.

Be careful not to mistake the direction of L (load side) and K (power supply side) in the through hole.

Install the special CT at any one phase.

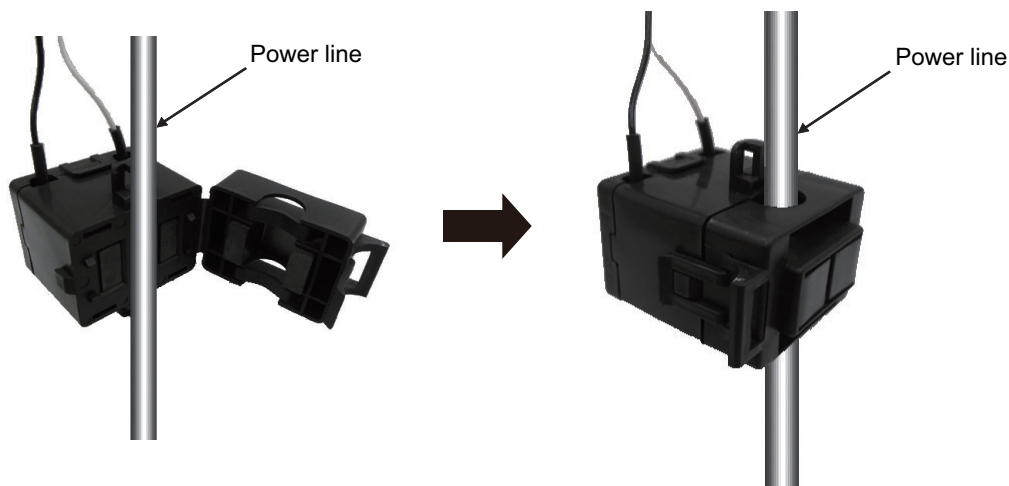

The K6CM side of the special CT provided cable is a ferrule terminal.

5-3 How to Connect to the Vibration & Temperature Sensor

This section describes how to connect the K6CM-VBM to the K6CM-VBS1 vibration and temperature sensor.

Appearance of K6CM-VBS1

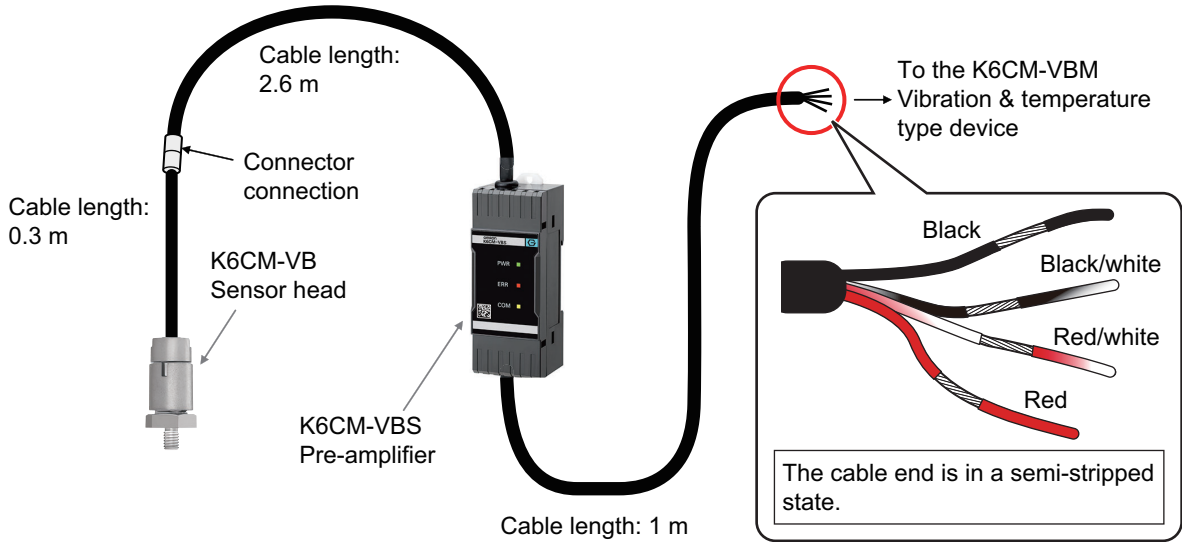

5-3-1 When Connecting Directly to the K6CM Device

Connect the cable by matching the pre-amplifier cable colors with the K6CM device terminal numbers as shown in the figure below.
 For details on how to use the push-in plus terminal block, refer to 5-4-2 *How to use the Push-In Plus Terminal Block* on page 5-20.

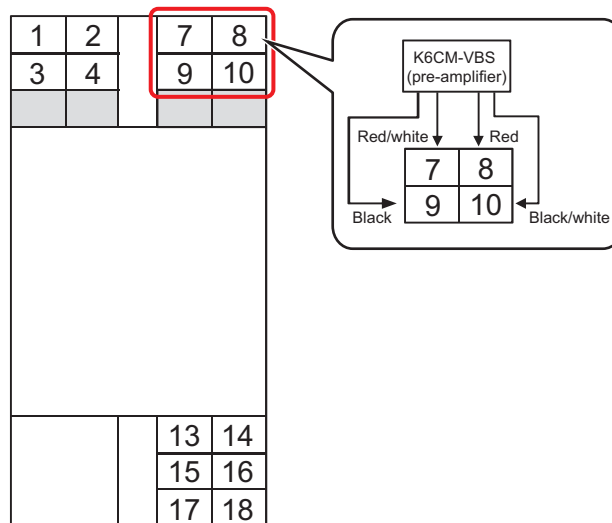

Additional Information

The pre-amplifier cable uses stranded wires. You can also remove the semi-stripped end parts and directly connect the wires, but we recommend using ferrules.

5-3-2 When Connecting by Extending the Cable

The cable between the pre-amplifier and K6CM device can be extended using a commercially available cable, connectors, and terminal block.

You can use either a screw terminal block type or push-in plus terminal block for the terminal block.

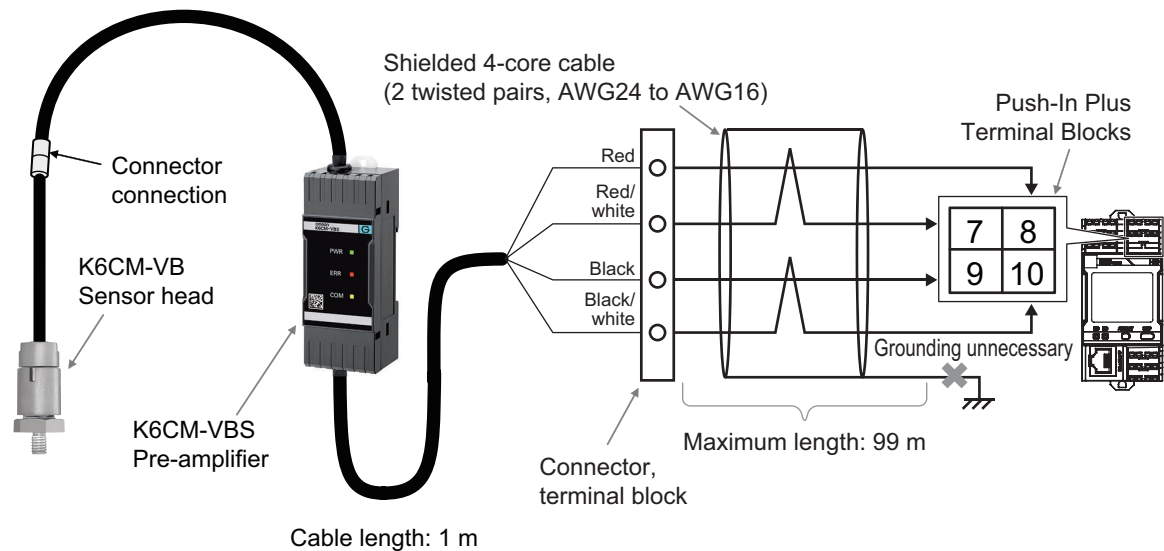

Additional Information

- The terminal block of the K6CM device is the push-in plus type only. Even if you join the cables via a screw terminal block type, we recommend using ferrules for connecting with the K6CM device.
- The cable can be extended in the same way also for the insulation resistance sensor (special ZCT (IRT)).

Detailed Conditions of Extension Cable

● Core wires (signal wires) of extension cable

Select the following cable.

The distance that the cable can be extended is a maximum of 99 m (the total maximum distance is 100 m including the 1 m cable supplied with the pre-amplifier).

Extension cable specifications

AWG24 to AWG16

4 core wires (2 twisted pairs)

Shielded cable (Grounding of shield is unnecessary.)



Additional Information

Recommended cable

We recommend 2464C BIOS-CL3-2402P-B manufactured by Bando Densen Co., Ltd., which satisfies the extension cable requirements. The cable is identical to the cable that is supplied with the pre-amplifier, and will allow you to match the colors of the core wires.

For details, contact Bando Densen Co., Ltd.. <http://www.bew.co.jp/>

- **When using connectors and terminal block**

Check that the connectors and terminal block meet the following requirements.

Item	Specification
Wire diameter	AWG24 to AWG16 x 4
Voltage rating	16 VDC or higher
Current rating	200 mA DC or higher

- **When using a push-in plus terminal block**

We recommend the OMRON XW5T-P DIN Track Terminal Block.

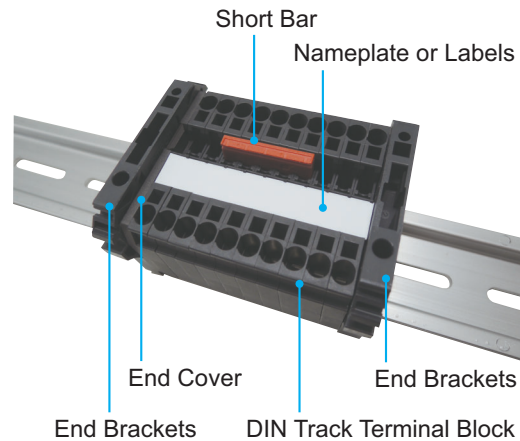

5-3-3 Recommended Ferrules and Crimp Tool

Use ferrules that are compatible with the wire diameter of AWG24.

For details on the recommended ferrules and crimp tool, refer to *5-4-3 Recommended Ferrules and Crimp Tools* on page 5-22.

5-4 How to Connect to the Push-In Plus Terminal Blocks

This section describes how to connect the K6CM devices to the Push-In Plus terminal blocks.

The following wiring terminals of the K6CM device are all push-in Plus terminals.

- Input wiring (sensor input, power supply input, external trigger input)
- Output wiring (transistor output)



Precautions for Safe Use

- To prevent wire materials from smoking or igniting, use the wiring materials given in the following table.

Recommended Wire	Stripping length (Without Ferrules)
0.25 to 1.5 mm ² (AWG24 to AWG16)	8 mm

- Make sure the crimp terminals for wiring are of the specified size.
- Do not insert more than one wire into each terminal insertion hole.
- Do not connect anything to terminals that are not being used.
- Do not wire anything to the release holes.
- Do not tilt or twist a flat-blade screwdriver while it is inserted into a release hole on the terminal block. The terminal block may be damaged.
- Insert a flat-blade screwdriver into the release holes at an angle. The terminal block may be damaged if you insert the screwdriver straight in.
- Do not allow the flat-blade screwdriver to fall out while it is inserted into a release hole.
- Keep wiring separate from high voltages and power lines that draw large currents. Do not place product wiring in parallel with or in the same path as high-voltage or high-current lines.
- Do not bend a wire past its natural bending radius or pull on it with excessive force. Doing so may cause the wire disconnection.
- When wiring the terminals, allow some leeway in the wire length.



Precautions for Correct Use

- When you are finished with wiring, make sure that no stranded wire comes loose.
- If you wire crossovers and connect terminal blocks in parallel, a large current will flow. Make sure that the current does not exceed 10 A.
- The terminal block may be damaged if the recommended tool is not used. Use the recommended flat-blade screwdriver to operate the release holes.

5-4-1 the Push-In Plus Terminal Block

Item	Specification
Construction	Push-in compatible with 1-pole 2-terminal interwiring wiring Hands free Front-in front and front-release
Applicable wires	Stranded wires, solid wires, or ferrules
Applicable wire size	0.25 to 1.5 mm ² (AWG24 to AWG16)
Wire insertion force	8 N max. for AWG20 wire
Screwdriver insertion force	15 N max.
Wire stripping length	10 mm, 12 mm
Ferrule length	8 mm, 10 mm
Recommended flat-blade screwdriver	XW4Z-00B (Omron) (Refer to the "Recommended Flat-blade Screwdriver" in 5-4-3 Recommended Ferrules and Crimp Tools on page 5-22.)
Current capacity	10 A (per pole)
Number of insertions	50 times
Recommended ferrules	Refer to the 5-4-3 Recommended Ferrules and Crimp Tools on page 5-22.

5-4-2 How to use the Push-In Plus Terminal Block

Nomenclature of the Terminal Block

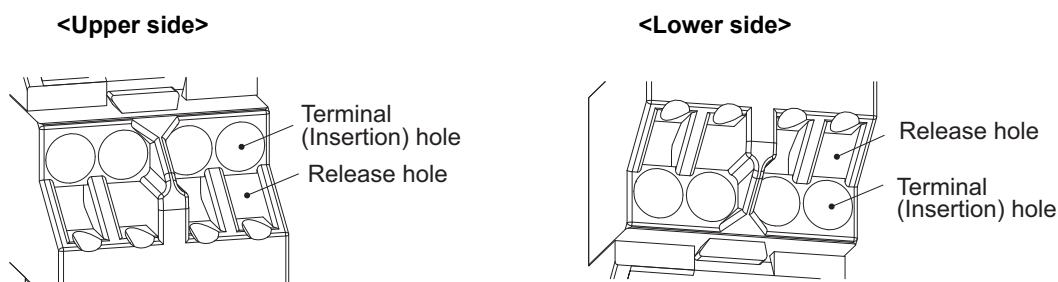

Connecting Wires with Ferrules and Solid Wires

Insert the solid wire or ferrule straight into the terminal block until the end strikes the terminal block.

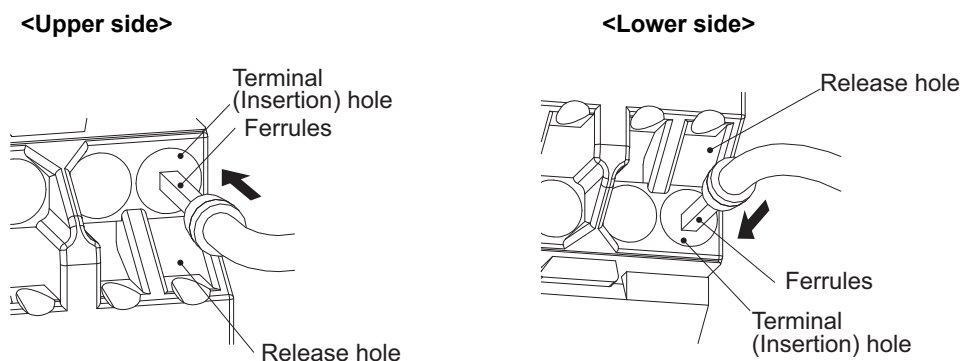

If a wire is difficult to connect because it is too thin, use a flat-blade screwdriver in the same way as when connecting stranded wire.

Connecting Stranded Wires

Use the following procedure to connect the wires to the terminal block.

- 1** Hold a flat-blade screwdriver at an angle and insert it into the release hole.
The angle should be between 10° and 15°.
If the flat-blade screwdriver is inserted correctly, you will feel the spring in the release hole.
- 2** With the flat-blade screwdriver still inserted into the release hole, insert the wire into the terminal hole until it strikes the terminal block.
- 3** Remove the flat-blade screwdriver from the release hole.

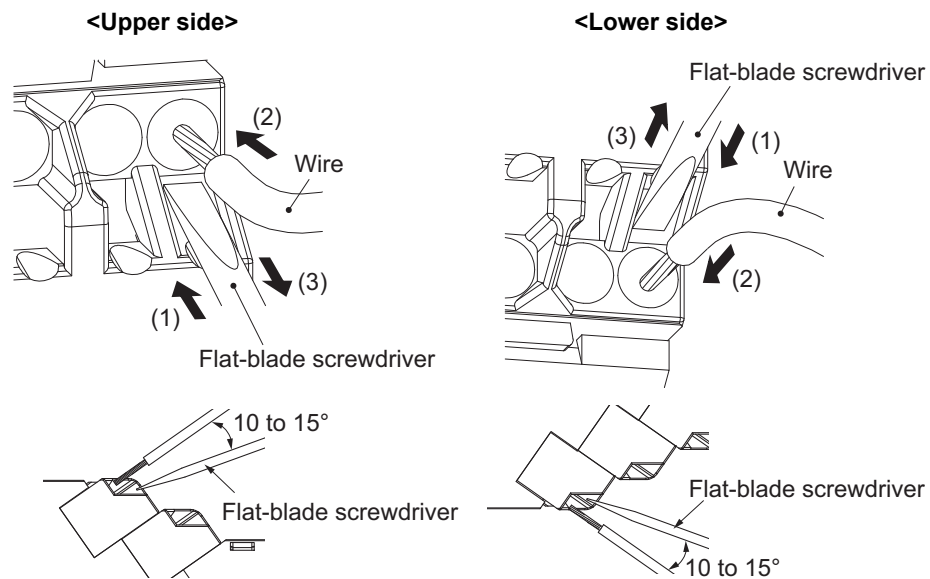

Checking Connection

- After the insertion, pull gently on the wire to make sure that it will not come off and the wire is securely fastened to the terminal block.
- If you use a ferrule with a conductor length of 10 mm, part of the conductor may be visible after the ferrule is inserted into the terminal block, but the product insulation distance will still be satisfied.
- To prevent short circuits, insert the stripped part of a stranded or solid wire or the conductor part of a ferrule until it is hidden inside the terminal insertion hole.
- For the stranded wires, make sure that some of the wires from adjacent terminals are not accidentally inserted.

Removing Wires from the Push-In Plus Terminal Block

Use the following procedure to remove wires from the terminal block.

The same method is used to remove stranded wires, solid wires, and ferrules.

- 1** Hold a flat-blade screwdriver at an angle and insert it into the release hole.
- 2** With the flat-blade screwdriver still inserted into the release hole, remove the wire from the terminal insertion hole.
- 3** Remove the flat-blade screwdriver from the release hole.

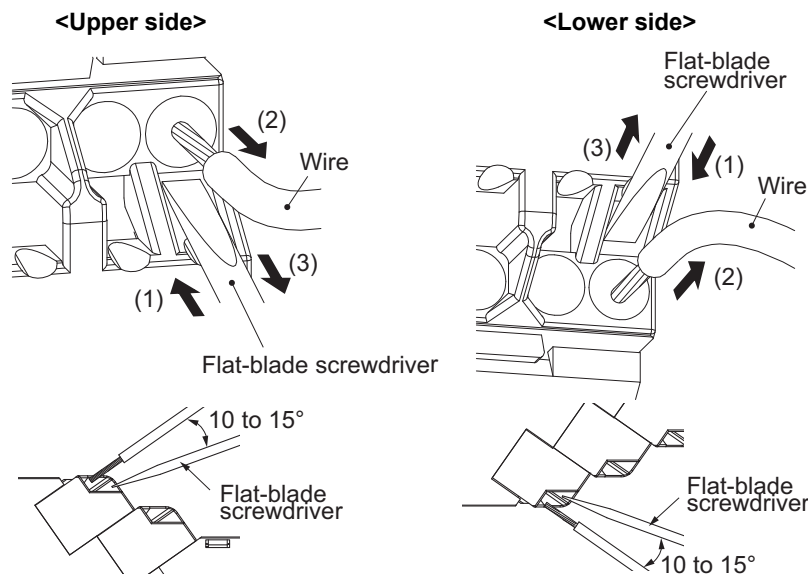

5-4-3 Recommended Ferrules and Crimp Tools

Recommended ferrules

Applicable wire		Ferrule Conductor length (mm)	Stripping length (mm) (Ferrules used)	Recommended ferrules		
(mm ²)	AWG			Manufactured by Phoenix Contact	Manufactured by Weidmuller	Manufactured by Wago
0.25	24	8	10	AI 0,25-8	H0.25/12	FE-0.25-8N-YE
		10	12	AI 0,25-10	----	----
0.34	22	8	10	AI 0,34-8	H0.34/12	FE-0.34-8N-TQ
		10	12	AI 0,34-10	----	----
0.5	20	8	10	AI 0,5-8	H0.5/14	FE-0.5-8N-WH
		10	12	AI 0,5-10	H0.5/16	FE-0.5-10N-WH
0.75	18	8	10	AI 0,75-8	H0.75/14	FE-0.75-8N-GY
		10	12	AI 0,75-10	H0.75/16	FE-0.75-10N-GY
1/1.25	18/17	8	10	AI 1-8	H1.0/14	FE-1.0-8N-RD
		10	12	AI 1-10	H1.0/16	FE-1.0-10N-RD
1.25/1.5	17/16	8	10	AI 1,5-8	H1.5/14	FE-1.5-8N-BK
		10	12	AI 1,5-10	H1.5/16	FE-1.5-10N-BK
Recommended crimp tool				CRIMPFOX6 CRIMPFOX6T-F CRIMPFOX10S	PZ6 roto	Variocrimp4

- Note 1. Make sure that the outer diameter of the wire coating is smaller than the inner diameter of the insulation sleeve of the recommended ferrule.
2. Make sure that the ferrule processing dimensions conform to the following figures.

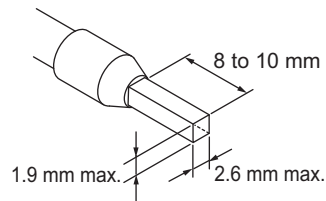

Recommended Flat-blade Screwdriver

Use a flat-blade screwdriver to connect and remove wires.

Use the following flat-blade screwdriver.

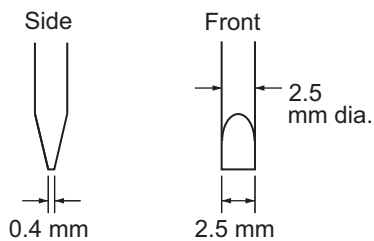

Model	Manufacturer
ESD0.40×2.5	Wera
SZS 0,4×2,5	Phoenix Contact
SZF 0-0.4×2.5*1	
0.4×2.5×75 302	Wiha
AEF.2,5×75	Facom
210-719	Wago
SDI 0.4×2.5×75	Weidmuller

*1. OMRON's exclusive purchase model XW4Z-00B is available to order as SZF 0-0.4 x 2.5 (manufactured by Phoenix Contact).

5-5 Diagram of Terminal Description

This section describes the wiring of the K6CM devices. Connect to the push-in Plus terminal blocks as follows.

● Model Number Legend

The "sensor input" and "power voltage" of the K6CM can be identified from the following parts of the model number.

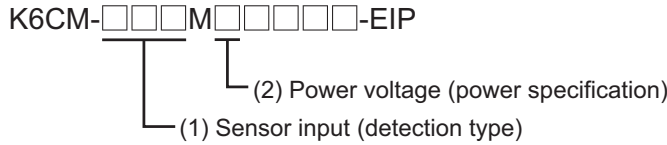

● Connection Diagram

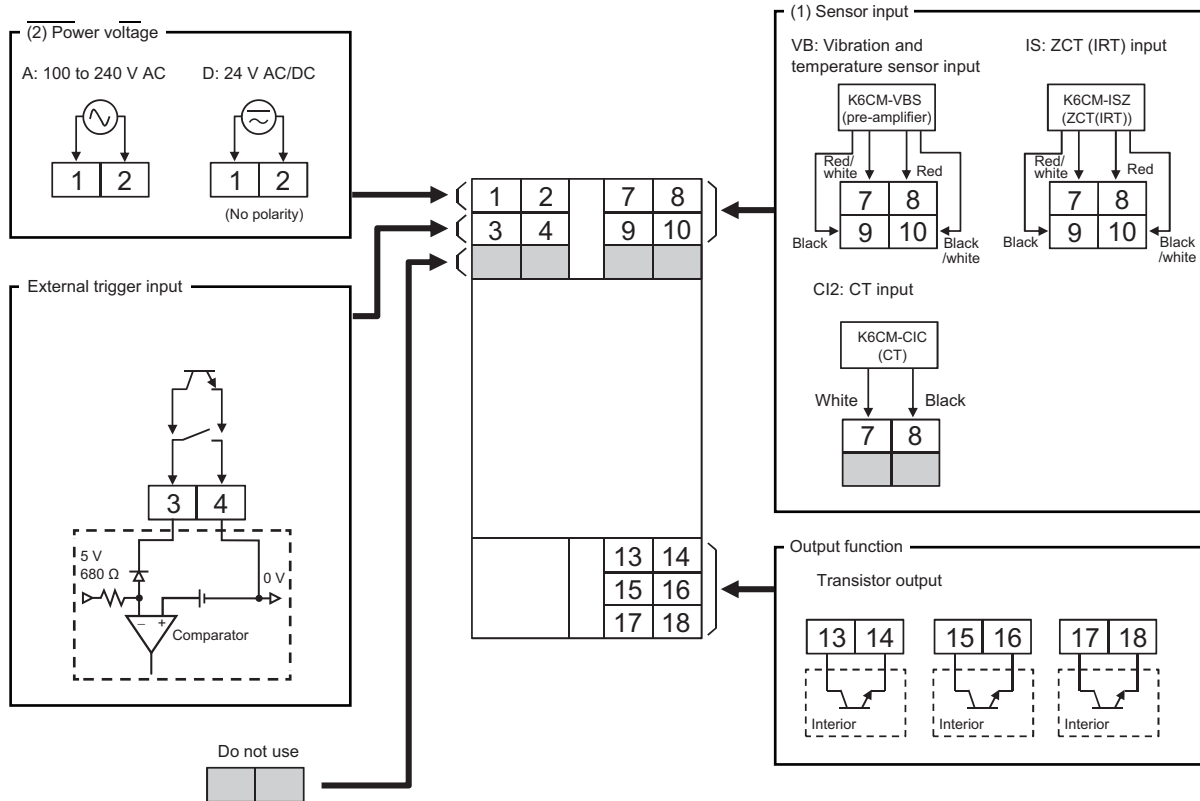

Each transistor output terminal has the following functions.

Terminal number	Transistor output	Function
13, 14	1	Warning output of comprehensive alarm
15, 16	2	Critical output of comprehensive alarm
17, 18	3	Self-diagnosis error output

5-6 I/O wiring

This section describes input/output wiring, power supply wiring, external trigger input wiring and transistor output wiring of the K6CM devices.

Wiring Diagram of the Comprehensive Current Diagnosis Type (K6CM-CI2)

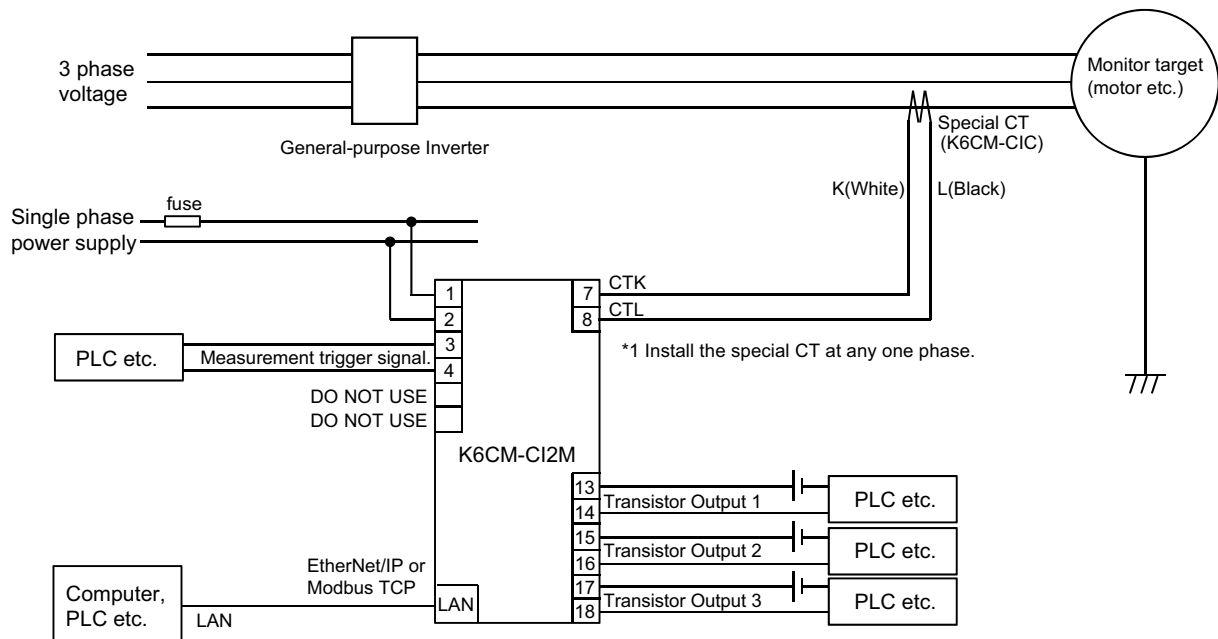

Precautions for Correct Use

Using a K6CM-CIM

- When the motor is driven by an inverter, it may not be possible to monitor the motor or load abnormalities. Refer to 3-4-1 *Comprehensive Current Diagnosis Type (K6CM-CI2)* on page 3-19 in 3-4 *Guide for Setting Alarm* on page 3-19 for details.

Using a K6CM-CI2M

- In an environment where the motor is driven by an inverter, if the degradation level 1 is used as the measurement value, it may not be possible to monitor the motor or load abnormalities. Therefore, it is recommended to use the degradation level 2. Refer to 3-4-1 *Comprehensive Current Diagnosis Type (K6CM-CI2)* on page 3-19 in 3-4 *Guide for Setting Alarm* on page 3-19 for details.
- Since the frequency band of the harmonics of the drive frequency and the frequency band in which errors such as load imbalance and misalignment appear are the same frequency band for a 2-pole meter, sensitivity may be reduced with degradation level 2.

Wiring Diagram of the Vibration & Temperature Type (K6CM-VB)

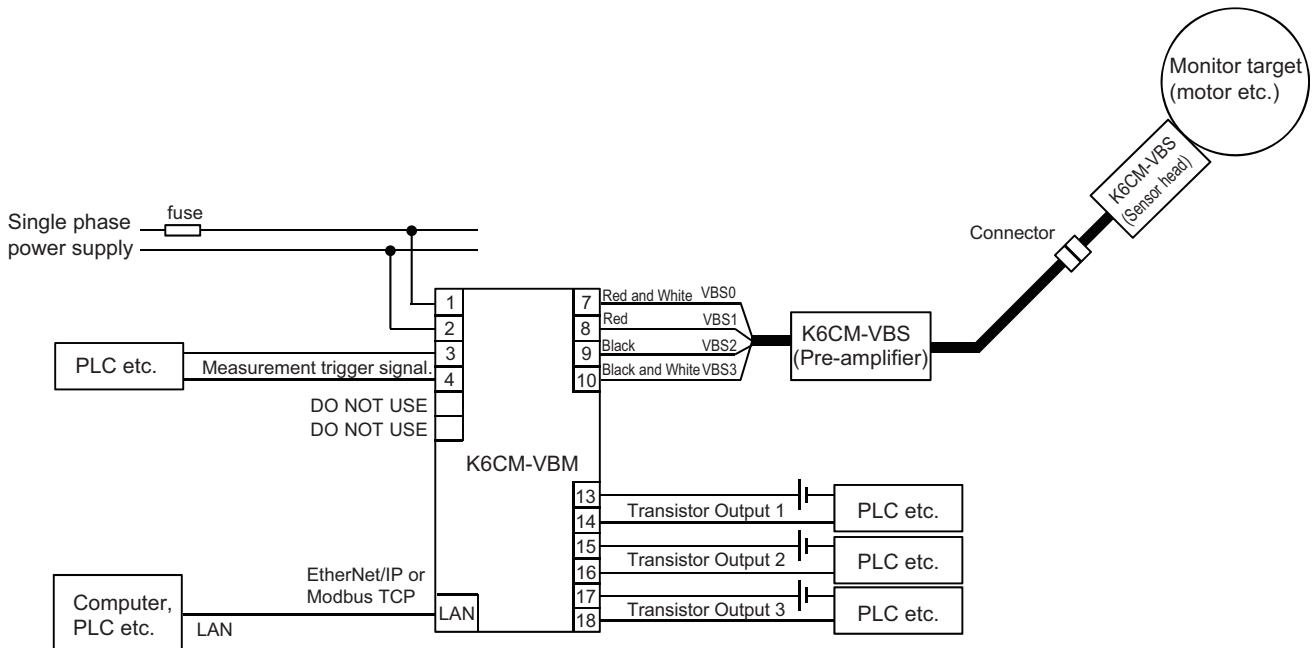

Note When you use an inverter to drive the motor, you may not be able to check the degradation tendency of the motor. However, under the following conditions, it is comparatively easier to check changes in acceleration.

- The inverter driving frequency is 50 Hz or more and the frequency is stable.
- The carrier frequency of the inverter is 12.5 kHz or more and the frequency is stable.

Use the device after testing in a similar environment as the installation environment during use.

Wiring Diagram of the Insulation Resistance Type (K6CM-IS)

● Three-phase Three Wire S-phase Grounded Delta Connection (With Inverter)

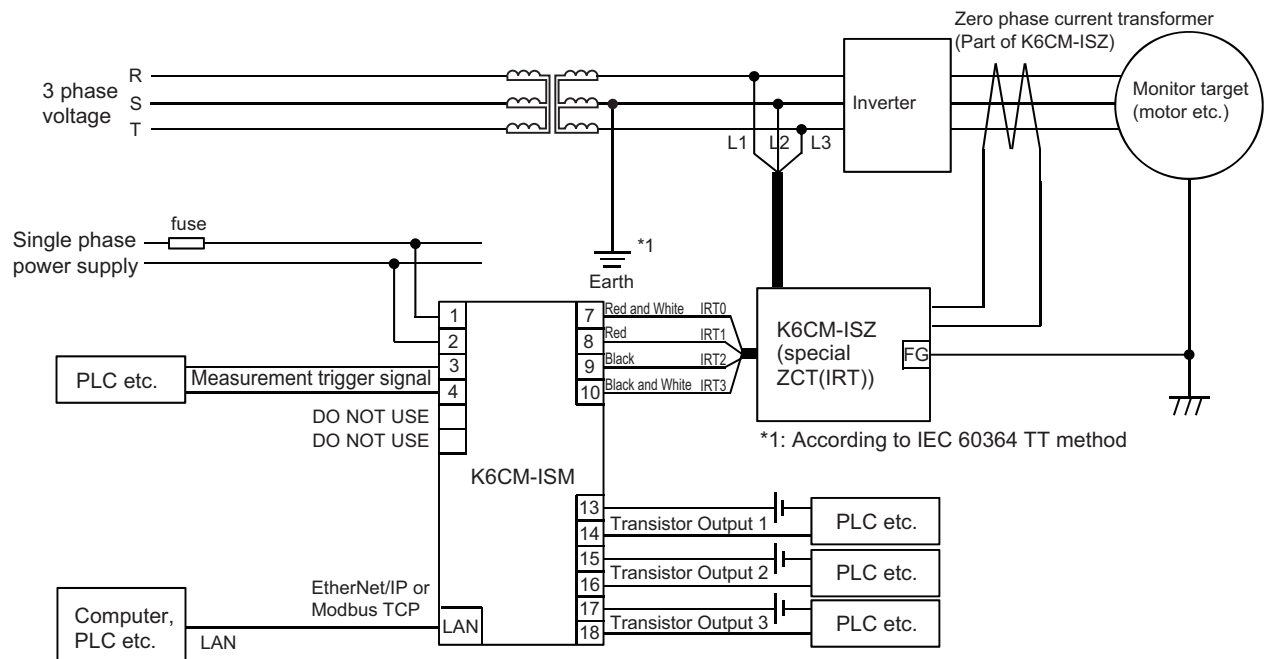

With the above wiring, set 0 for the Circuit topology and 1 for the Using inverter of the K6CM-ISM ^{*1}. Inverter special measurement setting changes according to inverter frequency (finv).

Example) When the commercial frequency $f = 50 \text{ Hz}$

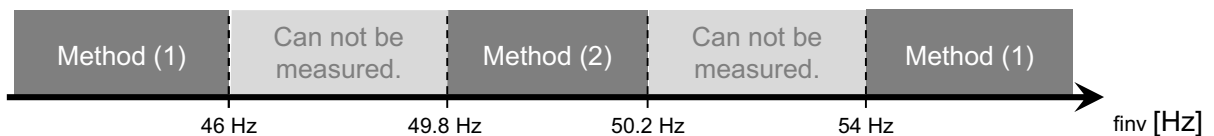

Method (1) ($\text{finv} \leq f - 4 \text{ Hz}$, $f + 4 \text{ Hz} \leq \text{finv}$)

- Inverter special measurement: Set to 0 (OFF) and start measurement.

Method (2) ($f - 0.2 \text{ Hz} \leq \text{finv} \leq f + 0.2 \text{ Hz}$)

- Inverter special measurement: Set to 0 (OFF) and start measurement.
- Switch the Inverter special measurement to 1 (ON) when the measurement value falls below $0.5 \text{ M}\Omega$. Measurement with higher accuracy will become possible.

Note In the case of $f - 4 \text{ Hz} < \text{finv} < f - 0.2 \text{ Hz}$, $f + 0.2 \text{ Hz} < \text{finv} < f + 4 \text{ Hz}$
It can not be measured correctly. Do not use the K6CM device.

*1. For details on how to change the setting, refer to 6-2-1 *Settings for Each Monitor Type of K6CM devices* on page 6-19 and 6-2-2 *Setting Parameters* on page 6-23.

● **Three-phase Three Wire S-phase Grounded Delta Connection (Without Inverter)**

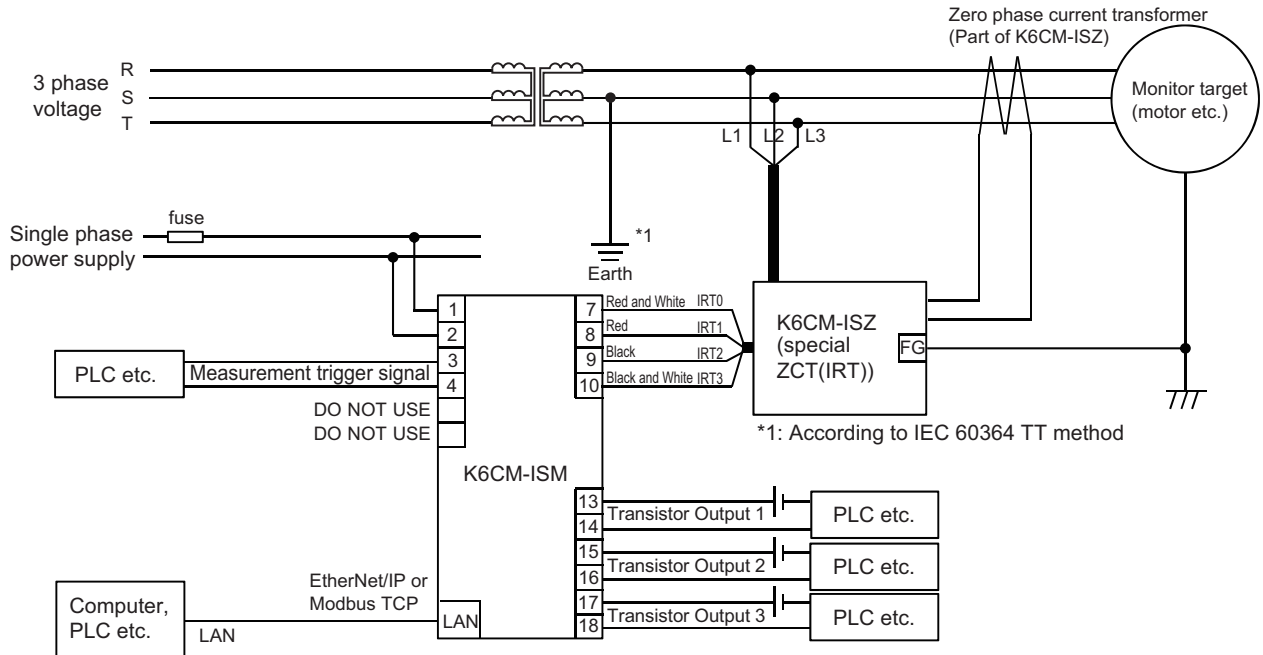

*1. With the above wiring, set 0 for the Circuit topology and 1 for the Using inverter of the K6CM-ISM, and start measurement.

For details on how to change the setting, refer to 6-2-1 *Settings for Each Monitor Type of K6CM devices* on page 6-19 and 6-2-2 *Setting Parameters* on page 6-23.

● **Three-phase Four-wire N-phase Grounded Y-connection Load Side Delta Connection (Without Inverter)**

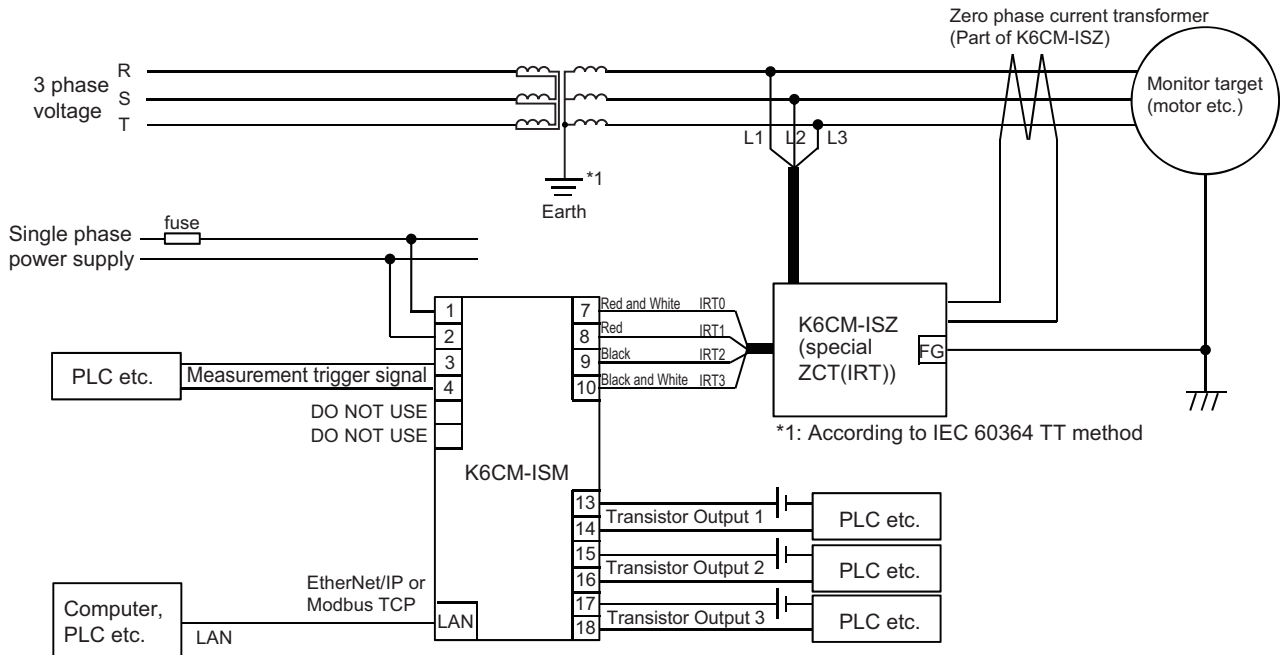

*1. With the above wiring, set 0 for the Circuit topology and 1 for the Using inverter of the K6CM-ISM, and start measurement.

For details on how to change the setting, refer to 6-2-1 *Settings for Each Monitor Type of K6CM devices* on page 6-19 and 6-2-2 *Setting Parameters* on page 6-23.

5-7 Network Wiring

This section describes the network wiring of the K6CM devices.

Connect the K6CM devices with the software tool, PLC, or PC via the industrial switching hub with the Ethernet cables.

Use an STP (shielded twisted-pair) cable of Ethernet category 5 or higher. Either cross cables or straight cables can be used, as the K6CM device has the Auto-MDI/MDIX function.

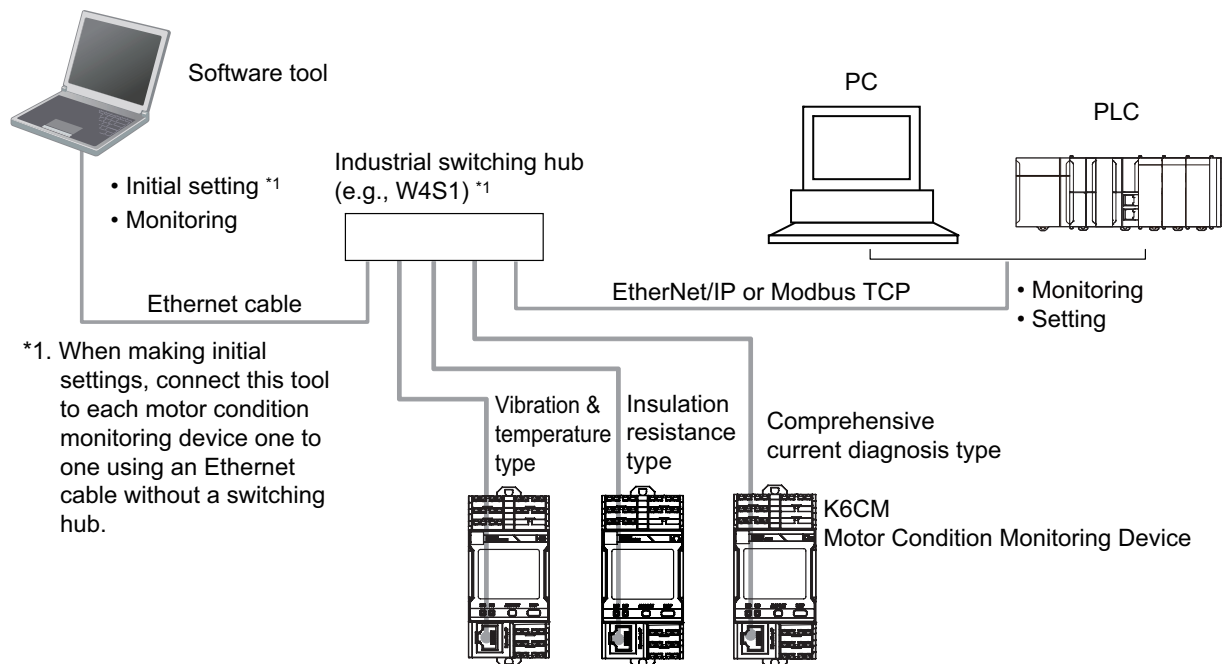

● Recommended Ethernet switches

Ethernet switches are recommended for use in environments that can be used in FA environments and devices that can use QoS (Packet Priority Control) dedicated to EtherNet/IP.

The following are recommended items.

Manufacturer	Model	Description
OMRON	W4S1-03B	Packet priority control (QoS): EtherNet/IP control data priority
	W4S1-05B	Failure detection: Broadcast storm, LSI error detection, 100Base-TX, Auto negotiation
	W4S1-05C	Number of ports: three for the W4S1-03B, or five each for the W4S1-05B and W4S1-05C Failure detection output (W4S1-05C only)
Cisco Systems, Inc	Consult the manufacturer. http://www.cisco.com/web/JP/index.html	
Contec USA, Inc.	Consult the manufacturer. http://www.contec.co.jp/	
Phoenix Contact USA	Consult the manufacturer. https://www.phoenixcontact.com/online/portal/jp	



Precautions for Correct Use

- Always use an Ethernet switch for tag data links in the network.
If EtherNet/IP tag data links (cyclic communications) are used with a repeating hub, the communications load on the network will increase. This will increase collisions and may prevent stable communications.
- Do not bend the communications cables past its natural bending radius or pull on it with excessive force.
- Do not place heavy objects on top of the communications cables or other wiring lines.
- Do not exceed the communications distance that is given in the specifications and use the specified communications cable.
- Set the switching hub connected to the K6CM devices as follows. If any setting other than the following is used, the link will be unstable, and normal communications are prevented.

K6CM		AUTO-Nego
Switching hub		
AUTO-Nego		Best
100 Mbps fixed	FULL	---
	HALF	OK

(Best = Recommended; OK = Allowed; --- = Not allowed)

- If the K6CM device was manufactured before April 30, 2019, a tag data link timeout may occur in the network system including the node configured for multicast communications. Use a switching hub with multicast filtering function to prevent multicast packets from reaching the K6CM devices.
-



How to Use the Motor condition monitoring Tool

This section describes how to operate the Motor condition monitoring Tool (Software Tool).

6-1	Screens	6-2
6-1-1	Start Screen	6-2
6-1-2	Monitoring Screen and Setting Screen	6-5
6-1-3	Common Menu and Toolbar List	6-11
6-1-4	Buttons on Device Setting	6-13
6-1-5	Software Tool Version Display Screen	6-18
6-2	Setting of K6CM Devices	6-19
6-2-1	Settings for Each Monitor Type of K6CM devices	6-19
6-2-2	Setting Parameters	6-23
6-2-3	Add a Device to an Existing Project	6-24
6-2-4	Motor (Device Group) Rename	6-25
6-2-5	Save Overwriting Project	6-26
6-2-6	Exit Project	6-26

6-1 Screens

Select [All Programs] | [OMRON] | [Motor condition monitoring tool].

Or double-click the shortcut icon () of the software tool on the desktop.

The software tool starts and the following screen is displayed. This screen is called "start screen".

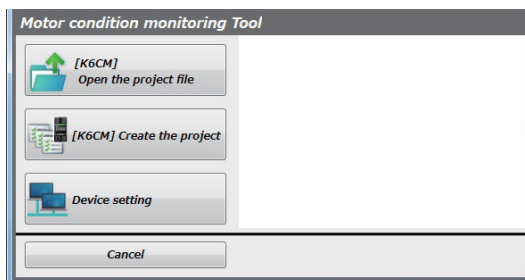

6-1-1 Start Screen

The overall screen transition from the start screen of the software tool is as follows.

Select the menu in the following order and use it.

The menu startup order	Contents
(1) [Device setting]	Communications driver between computer and K6CM Driver Launch the SYSMAC Gateway Console screen for setting the status of SYSMAC Gateway.
(2) [[K6CM] Create project]	Perform initial setting (IP address setting, parameter setting) and automatic project creation for the device.
(3) [[K6CM] Open the project file]	Open the project that you created and saved in step 2) above.

(3)Device setting

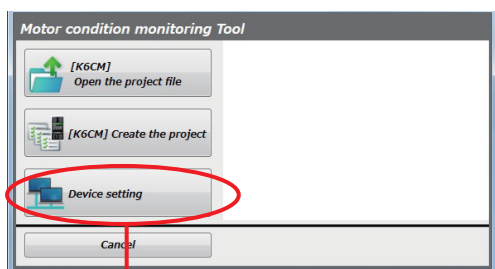

Start SYSMAC Gateway Console.

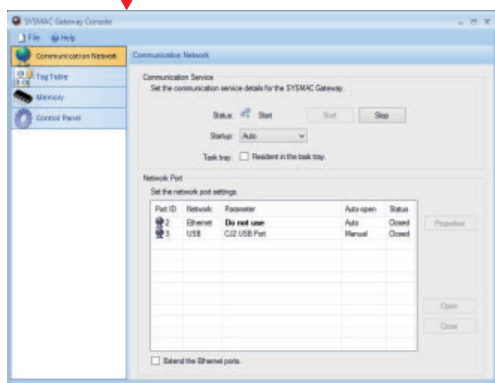

Configure communications service and network port. (For details, refer to 6-2 *Setting of K6CM Devices* on page 6-19.)

2) Create [K6CM] project.

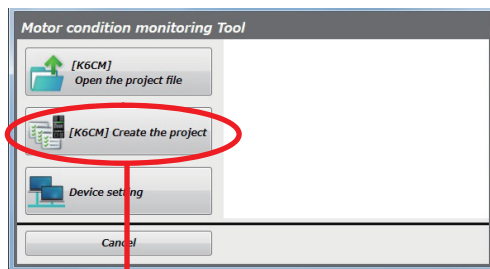

Create a new project.

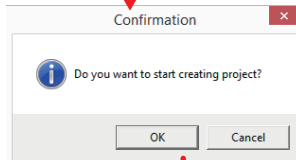

[Select the connecting method.] Dialog Box opens.

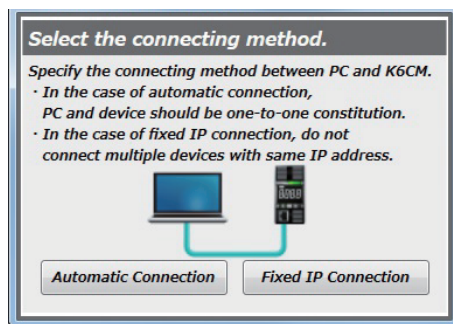

Select the connecting method with K6CM device.

For details, refer to "6-2 Setting of K6CM Devices on page 6-19"

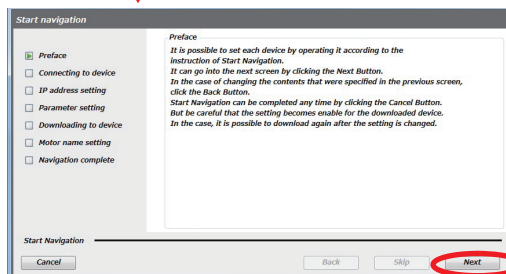

Perform IP address, parameter setting, motor name setting, etc.

For details, refer to "6-2 Setting of K6CM Devices on page 6-19"

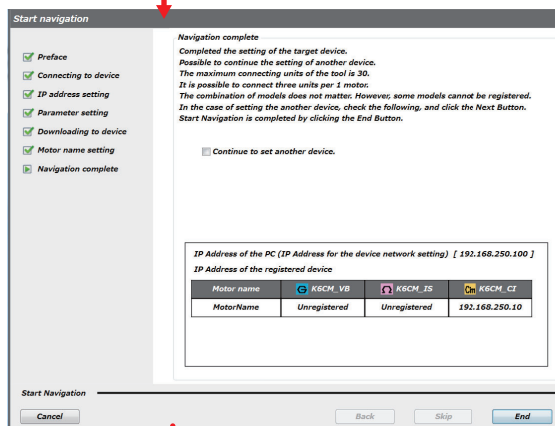

To monitoring screen

3) Open the [K6CM] project file

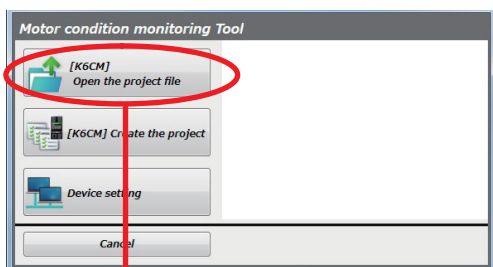

Open existing project file.

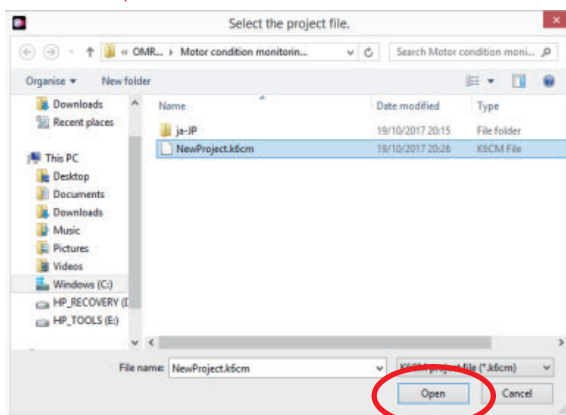

Select the project file and click [Open].

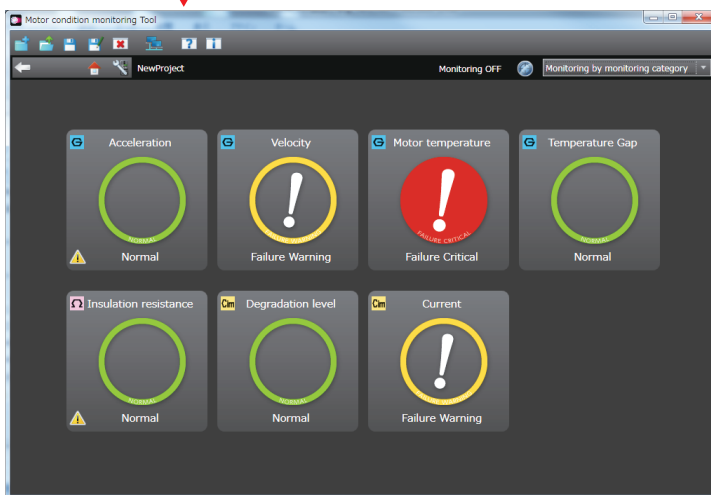

Monitoring screen with project saved starts.

The project consists of the following.

- Project file: This file defines the connection configuration of the K6CM.
- Setting file: This is a file for backing up and saving device setting values.
- Log file: The log of the monitoring result is saved.



Precautions for Correct Use

Be sure to select [Device setting] before selecting [[K6CM] Create project].

If you select [[K6CM] Create project] before selecting [Device setting], click the [Cancel] Button and close the screen. Click the [Cancel] Button and do not save the project, please exit. Then start the software tool again.

6-1-2 Monitoring Screen and Setting Screen

The following screen types are supported.

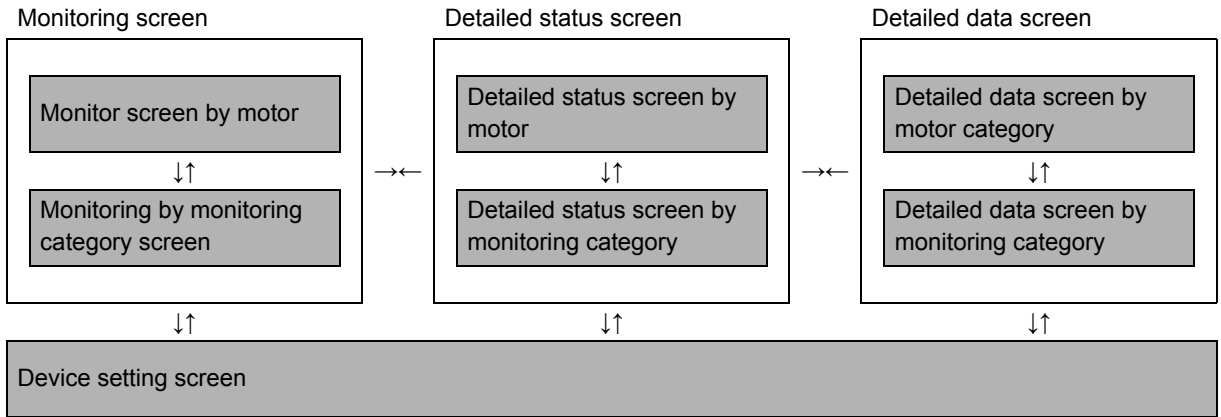

Monitoring screen

- Monitor screen by motor

Monitoring/Monitoring stopped

Switch between [Monitoring by motor category] and [Monitoring by monitoring category]

Motor name

Comprehensive alarm status
Green: Normal
Yellow: Failure Warning
Red: Failure Critical

Normal, Warning, or Critical displayed

Communications error occurred

Clicking one of the comprehensive alarm status indications for each motor will display the device group being used for monitoring the selected motor in the list.

● Detailed status screen by motor

- In case of bar display

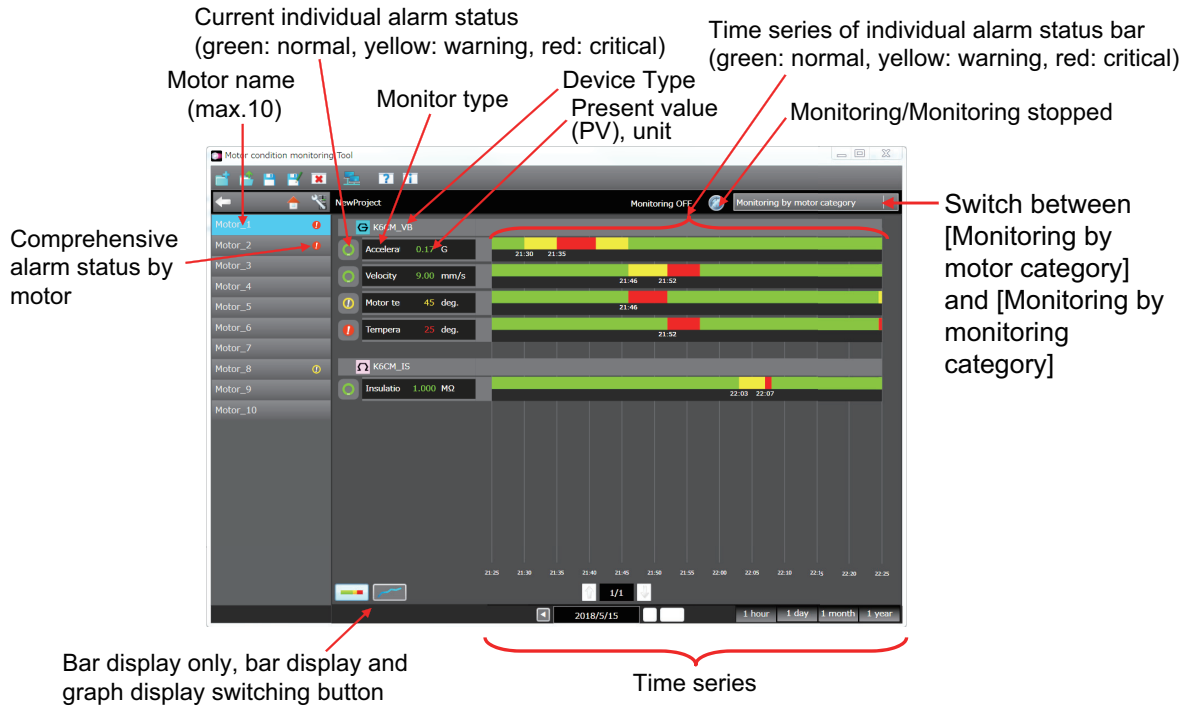

- In case of bar display and graph display

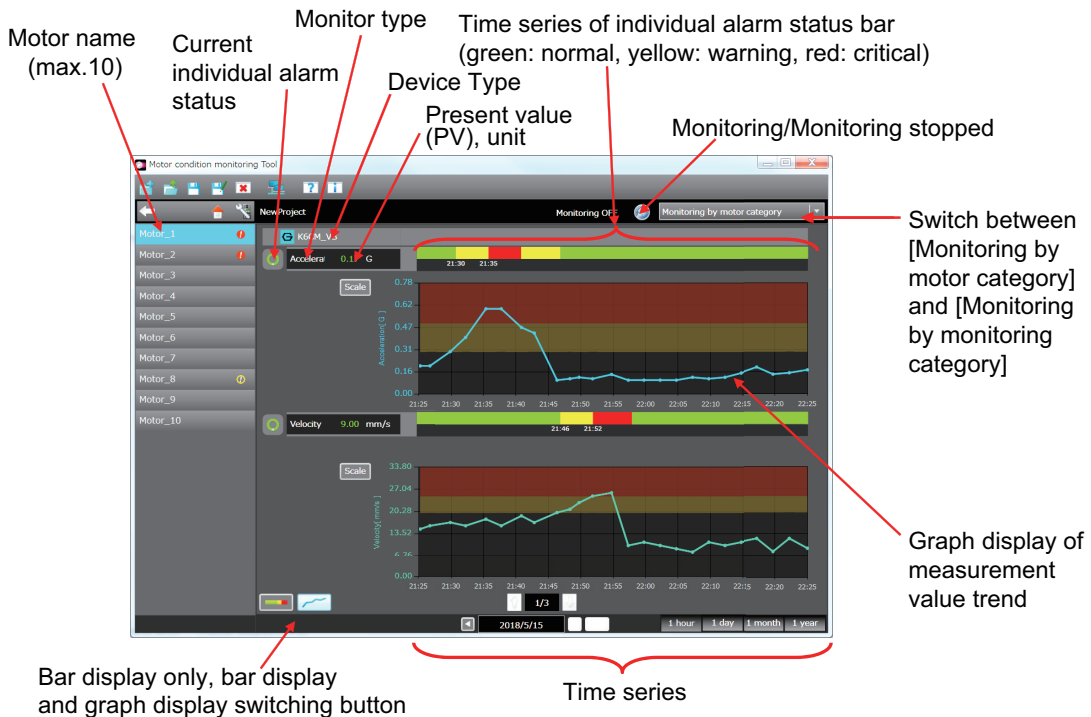

To display the detailed data of each device, click the "Current individual alarm status" on the left of each device.

The detailed data screen by motor category or by monitoring category is displayed.

● Detailed data screen by motor category

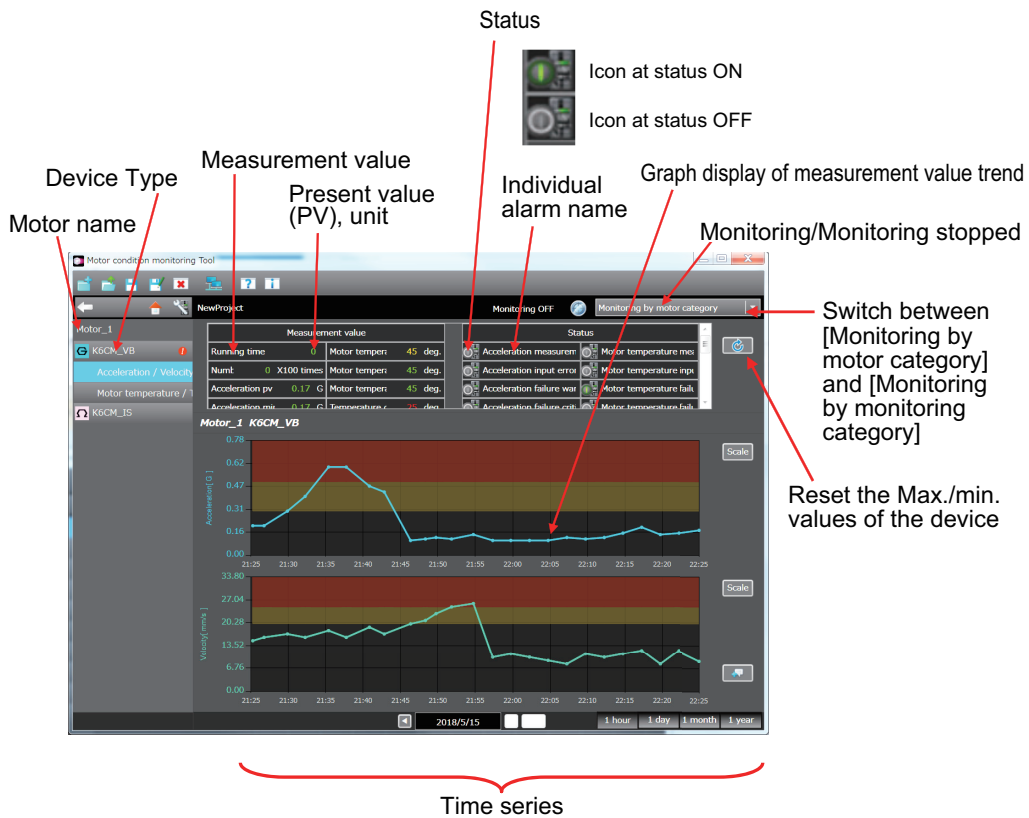

For details on the parameters displayed in the detailed data screen, refer to *A-8 Present Values* on page A-21.

- Note 1. The maximum value on the vertical axis of the graph automatically changes depending on the measurement value and alarm set value. With software tool version 1.2.0.0 or later, the vertical axis scale can be set arbitrarily.
- 2. The time series period can be switched to 1 hour / 1 day / 1 month / 1 year. If a period of more than 1 day is selected and displayed, data may be thinned out and displayed.

● **Monitoring screen by monitoring category**



Clicking one of the comprehensive alarm status indications for each motor will display the motor name and device name for each selected monitoring category in the list.

● **Detailed status screen by monitoring category**

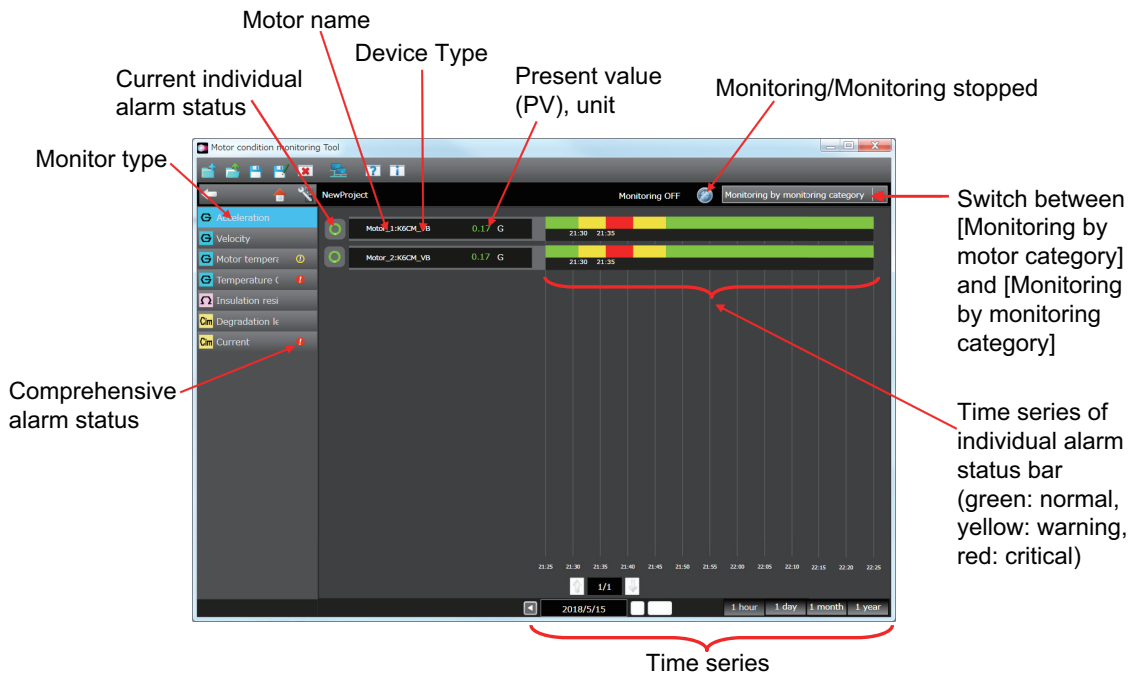

Clicking the current individual alarm status will display the detailed data screen by monitoring category.

Device setting screen

Click the  [Device setting] Button. The following device setting screen is displayed.

For details on the displayed parameters, refer to 6-2-1 *Settings for Each Monitor Type of K6CM devices* on page 6-19.

● Device setting screen

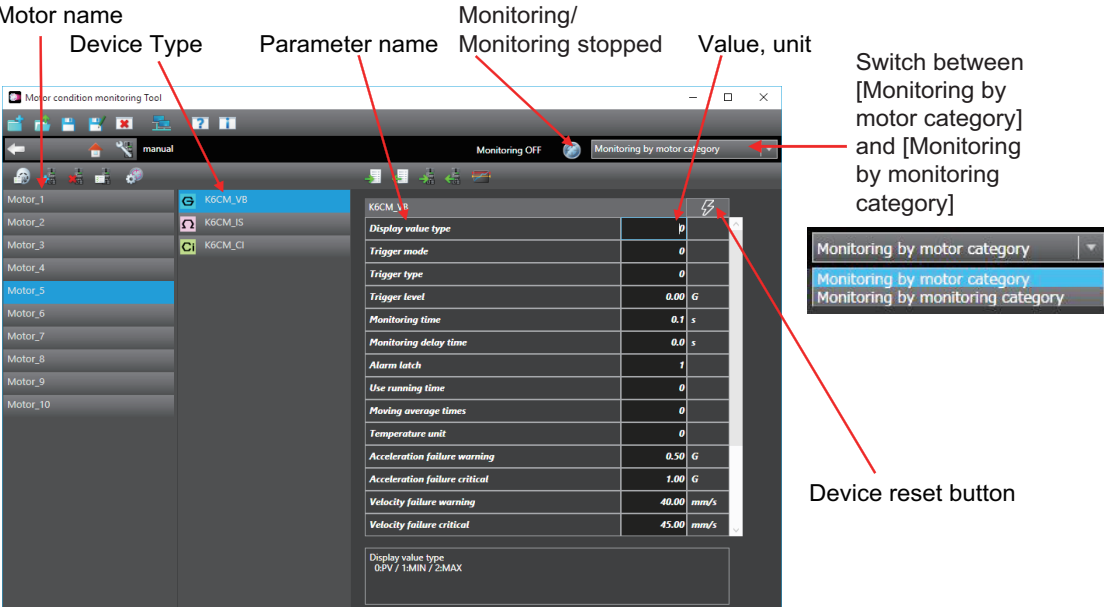

Motor name

Device Type

Parameter name

Monitoring/ Monitoring stopped

Value, unit

Switch between [Monitoring by motor category] and [Monitoring by monitoring category]

Monitoring by motor category

Monitoring by monitoring category

Device reset button

Parameter name	Value, unit
Display value type	p
Trigger mode	0
Trigger type	0
Trigger level	0.00 G
Monitoring time	0.1 s
Monitoring delay time	0.0 s
Alarm latch	1
Use running time	0
Moving average times	0
Temperature unit	0
Acceleration failure warning	0.50 G
Acceleration failure critical	1.00 G
Velocity failure warning	40.00 mm/s
Velocity failure critical	45.00 mm/s

Display value type
0PV / 1MIN / 2MAX



Version Information

If the following connection processing is performed in software tool version 1.3.0.0 or later, the Eip cpu version of the connected device is displayed on the right of the device type in the parameter name list.

- Connecting to device of start navigation
- Start monitoring
- Max./min. reset of detailed data screen
- Downloading (PC → device) of the setting screen
- Uploading (device → PC) of the setting screen
- Device reset of setting screen

6-1-3 Common Menu and Toolbar List

This section describes the following menu and toolbar in the upper left part common to the screen.

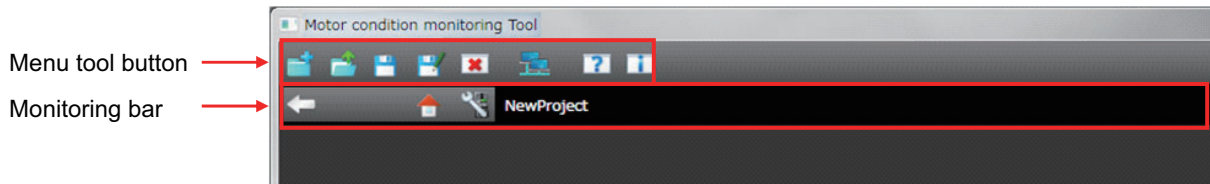

Menu tool button

Buttons and tooltips		Outline of operation	Enable / disabled condition
	Create new project	Display the screen for setting the configuration. If the current project has not been saved, a message will be displayed.	Selectable during monitoring execution (grayed out)
	Open project	Display "Open file" dialog. Equivalent to "[K6CM] Open project file" button when the software tool is started. If the current project is not saved, a message will be displayed.	Selectable during monitoring execution (grayed out)
	Save the project file	Save over the current project file. If you create a new file, the Save File dialog will be displayed and it will be saved with a name.	Selectable during monitoring execution (grayed out)
	Save the project as the specified name	The "Save file" dialog is displayed. Save the project with the specified file name.	Selectable during monitoring execution (grayed out)
	Exit	Exit the software tool. If the current project has not been saved, a message will be displayed.	Selectable during monitoring execution (grayed out)

Buttons and tooltips		Outline of operation	Enable / disabled condition
	SYSMAC Gateway Console	Launch the SYSMAC Gateway Console screen. 1. Make sure that "Startup" in the "Communication Service" field is "Automatic" and that "Status" is "Start". 2. In the [Network Port] field, configure the network port to be connected. 3. In the [Network Port] field, set the [Auto open] column of the network port to be used to "Automatic".	Selectable during monitoring execution (grayed out)

Buttons and tooltips		Outline of operation	Enable / disabled condition
	Display help menu	Displays the User's Manual.	----
	Version information	The version information screen is displayed.	----

Monitoring Bar



- Left end

Buttons and tooltips		Outline of operation
	Back	You can return to the previous screen. However, it cannot be used on the monitoring screen.
	Home	Returns to the monitoring screen.
	Device setting	You will be transferred to the device setting screen. For details of the device setting screen, see "Device setting screen" in 6-1-2 Monitoring Screen and Setting Screen on page 6-5.

- Center

Display	Outline of operation
	Indicates that monitoring is stopped. The file name of the project is displayed on the left side (the same applies below). "Stopped" is displayed on the right side.
	Indicates that monitoring is in progress, and that the entire monitoring data is normal. "Monitoring" is displayed on the right side.
	It is currently being monitored and indicates that "Warning" has occurred in one of the monitoring data. "Monitoring" is displayed on the right side.
	It is currently being monitored, and "Critical" has occurred in one of the monitoring data. "Monitoring" is displayed on the right side.

- Right end

Buttons and tooltips	Enable / disabled condition
	Indicates that monitoring is stopped. By pressing this button, monitoring will start.
	It is currently being monitored. By pushing this button, monitoring is stopped.

6-1-4 Buttons on Device Setting

This section describes the following setting screen tool buttons in the upper left part of the device setting screen.

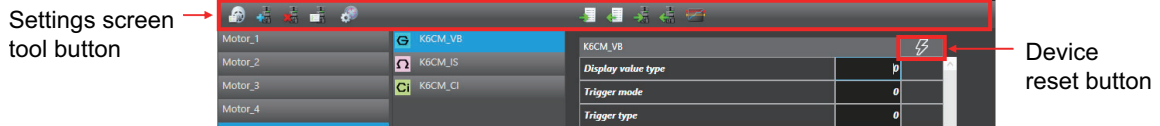

Buttons and tooltips		Outline of operation	Enable / disabled condition
	Motor information	Displays the screen to input motor information.	Selectable during monitoring execution (grayed out)
	Add device	Display a screen to add a device to the currently open project. Set the motor name, device type, IP address with the same value as already set for the actual device. Note : The IP address of the K6CM device cannot be set from here.	Selectable during monitoring execution (grayed out)
	Delete device	Delete the selected device.	Selectable during monitoring execution (grayed out)
	Device setting	Display the screen to change the IP address of the device. Motor group name and device type can not be changed and displayed.	Selectable during monitoring execution (grayed out)
	Monitoring setting	Displays the setting screen for the monitoring cycle. Set the cycle for reading the measurement value of the K6CM device.	Selectable during monitoring execution (grayed out)
	Save file	Save the setting values displayed in the software tool. If implemented during monitoring, priority will be given over monitoring. Therefore, there is a possibility that the monitoring may be delayed or the save may fail due to an error.	----
	Read file	If implemented during monitoring, priority will be given over monitoring. Therefore, monitoring may be delayed or failed due to an error.	----
	Downloading (PC→device)	Writes the setting values displayed in the software tool to the target device. If implemented during monitoring, priority will be given over monitoring. As a result, monitoring may be delayed or failed due to communications error.	----
	Uploading (Device→PC)	Reads the setting values of the target device to the software tool. If implemented during monitoring, priority will be given over monitoring. As a result, monitoring may be delayed or failed due to communications error.	----
	Guide for Setting Alarm (K6CM_VB)	Starts the guide for calculating and setting the acceleration and velocity alarm threshold values of the K6CM-VB. The button is displayed only when the K6CM-VB is selected.	Selectable during monitoring execution (grayed out)
	Device reset	Perform a device reset (restart the device) for the target device. It is used to validate the setting after changing the setting value.	----

Version Information

Guide for Setting Alarm (K6CM_VB) is displayed with software tool version 1.3.0.0 or later.

● **Setting screen Each screen to be started from the tool button**

-  [Motor information] Button

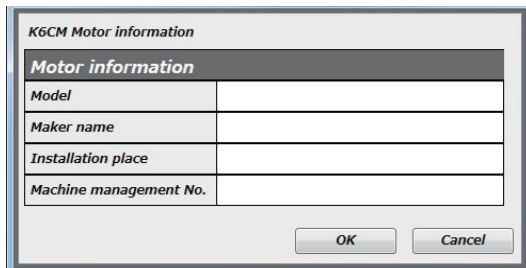

You can enter the location of the motor and the model of the motor.

-  [Add device] Button

(1) Add a device to the currently open project.

Set the motor name, device type, and the IP address already set for the K6CM device, and click the [Add] Button.

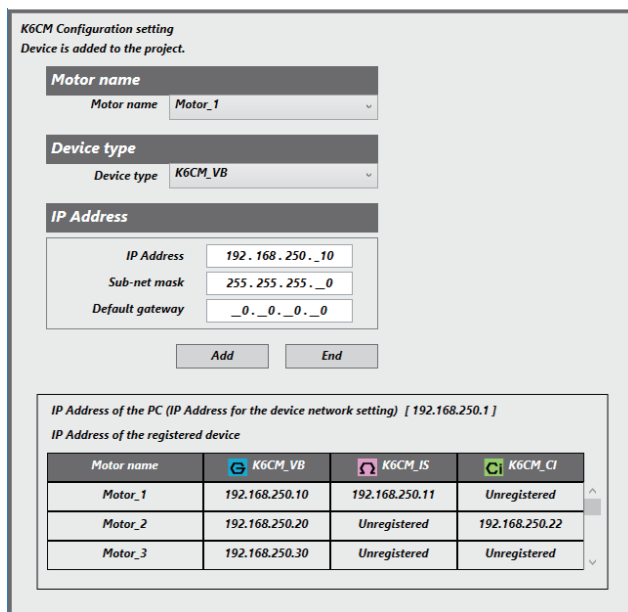

(2) To add more devices, repeat (1).

If there are no other devices to add, click the [End] Button.

Note If the entered IP address is duplicated with the IP address of the already registered devices, or if the same device type exists under the same motor name, the following [Error] Dialog Box will be displayed. Please click the [OK] Button and take necessary action.

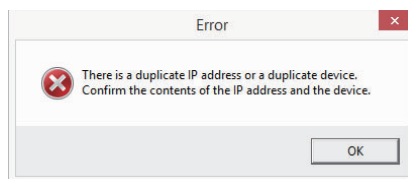

Version Information

With software tool version 1.2.0.0 or later, the column for displaying the IP addresses of your PC and registered devices are displayed.

-  [Device setting] Button
 Change the IP address of the device.
 IP address, subnet mask, default gateway.

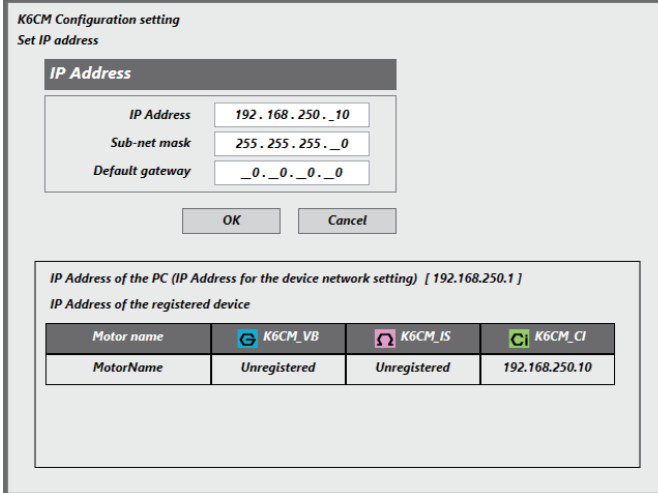



K6CM Configuration setting
Set IP address

IP Address

IP Address: 192.168.250.10
 Sub-net mask: 255.255.255.0
 Default gateway: .0.0.0

OK Cancel

IP Address of the PC (IP Address for the device network setting) [192.168.250.1]
 IP Address of the registered device

Motor name	 K6CM_VB	 K6CM_IS	 K6CM_CI
MotorName	Unregistered	Unregistered	192.168.250.10

Version Information

With software tool version 1.2.0.0 or later, the column for displaying the IP addresses of your PC and registered devices are displayed.

-  [Monitoring setting] Button
 Change the monitoring cycle.
 Can be set in the range of 5 seconds to 366 days. (The initial value is 600 seconds.)
 The monitoring cycle is the cycle at which the software tool collects measurement values from the K6CM devices.
 The measurement values are collected by the software tool at that cycle, regardless of the K6CM device state such as the use of trigger or the determination of measurement value.

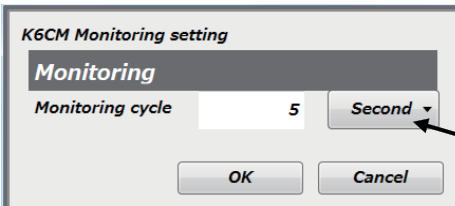

K6CM Monitoring setting

Monitoring

Monitoring cycle: 5 Second

OK Cancel

Using this pull down list allows you to change the unit of monitoring cycle. Selectable units are seconds, minutes, hours, and days.

Around 1 day for the monitoring cycle is recommended.

Version Information

With software tool version 1.2.0.0 or later, the unit of monitoring cycle can be set.

-  [Save file] Button
 Specify the parameter save destination and click the [Save] Button.

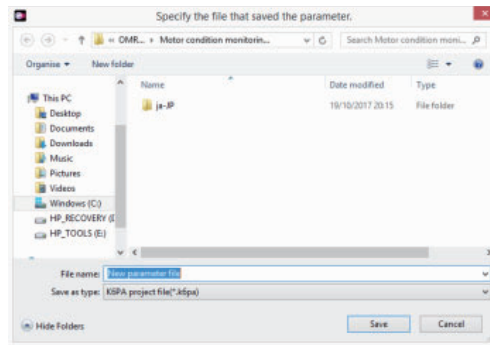

-  [Read file] Button
 Specify the setting file and click the [Open] Button.

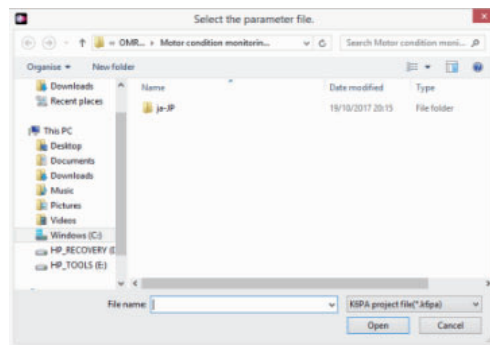

-  [Downloading (PC→device)] Button
 To write the setting value to the K6CM device, click the [OK] Button. If you do not want to write it, click the [Cancel] Button.

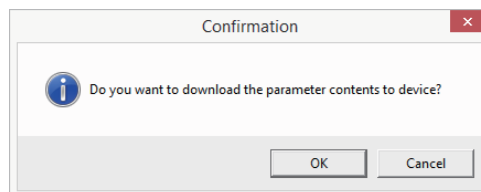

-  [Uploading (Device→PC)] Button
 To read the setting value from the K6CM device, click the [OK] Button. If you do not want to read it, click the [Cancel] Button.

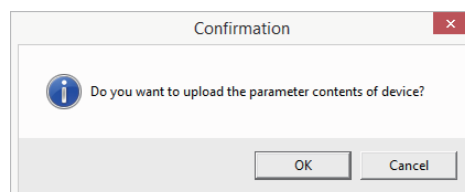

-  [Guide for Setting Alarm (K6CM_VB)] Button

When the specified values related to the acceleration and velocity alarm values of the K6CM-VB are entered, the alarm values (warning and critical) are calculated automatically.

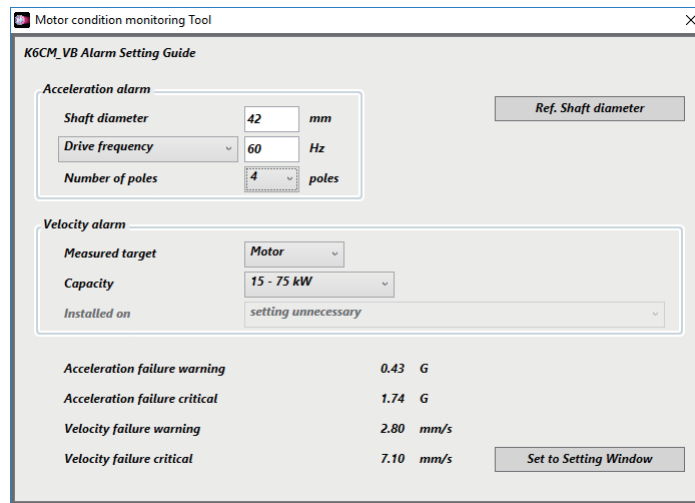

Motor condition monitoring Tool

K6CM_VB Alarm Setting Guide

Acceleration alarm

Shaft diameter mm

Drive frequency Hz

Number of poles poles

Velocity alarm

Measured target

Capacity

Installed on

Acceleration failure warning 0.43 G

Acceleration failure critical 1.74 G

Velocity failure warning 2.80 mm/s

Velocity failure critical 7.10 mm/s



Additional Information

When the [Shaft diameter] button is clicked, the motor shaft diameter list document is displayed.

If the [Set to Setting Window] button is clicked when the alarm values have been calculated, the calculated alarm values are set in the parameter list on the device setting screen.

6-1-5 Software Tool Version Display Screen

You can check the version of software tool by clicking  (Version information) Button.



6-2 Setting of K6CM Devices

The setting of the K6CM device can be set by either of the following two methods:

- How to set in the start navigation of project creation
- How to set on the device setting screen after project creation

6-2-1 Settings for Each Monitor Type of K6CM devices

The setting values by monitor type are shown in a list.

Support for each parameter depends on the Eip cpu version. For details, refer to *A-11 Version Compatibility A-51* on page A-1.

● Comprehensive current diagnosis type (K6CM-CI2)

Parameter name	Setting range	Description	Default
Display value type	0: PV (Present value) 1: MIN 2: MAX	Set which measurement value is displayed in the 7 segment display on the front of the K6CM device.	0: PV (Present value)
Trigger mode	0: Free run 1: External trigger 2: Internal trigger	Set the measurement mode.	0: Free run
Trigger type	0: Rising edge 1: Falling edge 2: Level	Set the trigger measurement start condition. Setting is not required when the trigger mode is "Free run".	0: Rising edge
Trigger level	Current range 5 A: 0.00 to 99.99 Other current range: 0.0 to 999.9	For "Internal trigger", set the measurement value to start trigger measurement. Setting is not required when the trigger mode is "Free run" or "External trigger".	0.00
Monitoring time	0.1 to 600.0 seconds	Set the monitoring time.	0.1
Alarm latch	0: Disable 1: Enable	Set the latch function when an alarm is detected.	1: Enable
Use Running Time	0: OFF 1: ON	Set the function to detect the life of the K6CM device.	0: OFF
Moving average times	0: OFF 1: 2 times 2: 4 times 3: 8 times 4: 16 times 5: 32 times	Every time the measurement value is sampled, the data of the past n times including the sampling data of that time is averaged. (n is the moving average number on the shown left column.)	0: OFF
Current range	0: 5 A 1: 25 A 2: 100 A 3: 200 A 4: 400 A 5: 600 A	Set the range according to the current flowing in the equipment to be monitored.	3: 200 A
Current failure warning threshold	Current range 5 A: 0.00 to 99.99 Other current range: 0.0 to 999.9	Set a threshold value for outputting individual alarm warning of the current.	Current range 5 A: 20.00 Other current range: 200.0
Current failure critical threshold	Current range 5 A: 0.00 to 99.99 Other current range: 0.0 to 999.9	Set a threshold value for outputting individual alarm critical of the current.	Current range 5 A: 20.00 Other current range: 200.0

Parameter name	Setting range	Description	Default
Degradation level 1 failure warning	0 to 9999	Set a threshold value for outputting individual alarm warning of the degradation level 1.	30
Degradation level 1 failure critical	0 to 9999	Set a threshold value for outputting individual alarm critical of the degradation level 1.	50
Degradation level 2 failure warning	0 to 9999	Set a threshold value for outputting individual alarm warning of the degradation level 2.	20
Degradation level 2 failure critical	0 to 9999	Set a threshold value for outputting individual alarm critical of the degradation level 2.	50
Transistor output method	0: Normally Close 1: Normally Open	Select transistor output method.	0: Normally Close
Monitoring delay time	0.0 to 600.0 seconds	Set the delay time from the trigger input to the start of measurement.	0.0
Current moving average times	0: OFF 1: 2 times 2: 4 times 3: 8 times 4: 16 times 5: 32 times	Set the current moving average times.	0: OFF
Degradation level 1 moving average times	0: OFF 1: 2 times 2: 4 times 3: 8 times 4: 16 times 5: 32 times	Set the degradation level 1 moving average times.	3: 8 times
Degradation level 2 moving average times	0: OFF 1: 2 times 2: 4 times 3: 8 times 4: 16 times 5: 32 times	Set the degradation level 2 moving average times.	0: OFF

● Vibration & temperature type (K6CM-VB)

Parameter name	Setting range	Description	Default
Display value type	0: PV (Present value) 1: MIN 2: MAX	Set which measurement value is displayed in the 7 segment display on the front of the K6CM device.	0: PV (Present value)
Trigger mode	0: Free run 1: External trigger 2: Internal trigger	Set the measurement mode.	0: Free run
Trigger type	0: Rising edge 1: Falling edge 2: Level	Set the trigger measurement start condition. Setting is not required when the trigger mode is "Free run".	0: Rising edge
Trigger level	Current range 5 A: 0.00 to 99.99 Other current range: 0.0 to 999.9	For "Internal trigger", set the measurement value to start trigger measurement. Setting is not required when the trigger mode is "Free run" or "External trigger".	0.00
Monitoring time	0.1 to 600.0	Set the time to continue the measurement when the trigger mode is set to "External trigger" or "Internal trigger" with the trigger type "Rising edge" or "Falling edge". Setting is not required when the trigger mode is "Free run" or the trigger type is "Level".	0.1
Alarm latch	0: Disable 1: Enable	Set the latch function when an alarm is detected.	1: Enable

Parameter name	Setting range	Description	Default
Use Running Time	0: OFF 1: ON	Set the function to detect the life of the K6CM device.	0: OFF
Moving average times	0: OFF 1: 2 times 2: 4 times 3: 8 times 4: 16 times 5: 32 times	Every time the measurement value is sampled, the data of the past n times including the sampling data of that time is averaged. (n is the moving average number on the shown left column.)	0: OFF
Temperature unit	0: °C 1: °F	Sets the temperature unit.	0: °C
Acceleration failure warning	0 to 9999	Sets the acceleration failure warning threshold.	50
Acceleration failure critical	0 to 9999	Sets the acceleration failure critical threshold.	100
Velocity failure warning	0 to 9999	Sets the velocity failure warning threshold.	4000
Velocity failure critical	0 to 9999	Sets the velocity failure critical threshold.	4500
Motor temperature failure warning	0 to 9999	Sets the Motor temperature failure warning threshold.	80
Motor temperature failure critical	0 to 9999	Sets the Motor temperature failure critical threshold.	80
Temperature gap failure warning	0 to 9999	Sets the Temperature gap failure warning.	80
Temperature gap failure critical	0 to 9999	Sets the Temperature gap failure critical.	80
Transistor output method	0: Normally Close 1: Normally Open	Select transistor output method.	0
Monitoring delay time	0.0 to 600.0 seconds	Set the delay time from the trigger input to the start of measurement.	0.0

● Insulation resistance type (K6CM-ISM)

Parameter name	Setting range	Description	Default
Display value type	0: PV (Present value) 1: MIN 2: MAX	Sets which measurement value is displayed in the 7 segment display on the front of the K6CM device.	0: PV (Present value)
Trigger mode	0: Free run 1: External trigger 2: Internal trigger	Set the measurement mode.	0: Free run
Trigger type	0: Rising edge 1: Falling edge 2: Level	Set the trigger measurement start condition. Setting is not required when the trigger mode is "Free run".	0: Rising edge
Trigger level	Current range 5 A: 0.00 to 99.99 Other current range: 0.0 to 999.9	For "Internal trigger", set the measurement value to start trigger measurement. Setting is not required when the trigger mode is "Free run" or "External trigger".	0.00
Monitoring time	0.1 to 600.0	Set the time to continue the measurement when the trigger mode is set to "External trigger" or "Internal trigger" with the trigger type "Rising edge" or "Falling edge". Setting is not required when the trigger mode is "Free run" or the trigger type is "Level".	0.1
Alarm latch	0: Disable 1: Enable	Set the latch function when an alarm is detected.	1: Enable
Use Running Time	0: OFF 1: ON	Set the function to detect the life of the K6CM device.	0: OFF

Parameter name	Setting range	Description	Default
Moving average times	0: OFF 1: 2 times 2: 4 times 3: 8 times 4: 16 times 5: 32 times	Every time the measurement value is sampled, the data of the past n times including the sampling data of that time is averaged. (n is the moving average number on the shown left column.)	0: OFF
Circuit topology	0: Three-phase three-wire system, S-phase grounding 1: Three-phase four-wire system, N-phase grounding, delta connection load	Set the circuit topology according to the distribution method of the equipment to be monitored.	0: Three-phase three-wire system, S-phase grounding
Using inverter	0: OFF 1: ON	Set according to the presence or absence of the inverter of the equipment to be monitored.	0: OFF
Inverter special measurement	0: OFF 1: ON	Set according to the inverter frequency setting of the equipment to be monitored.	0: OFF
Insulation resistance failure warning	0.000 to 9.999	Set a threshold value for outputting individual alarm warning of the insulation resistance.	0.800
Insulation resistance failure critical	0.000 to 9.999	Set a threshold value for outputting individual alarm critical of the insulation resistance.	0.400
Transistor output method	0: Normally Close 1: Normally Open	Select transistor output method.	0
Monitoring delay time	0.0 to 600.0 seconds	Set the delay time from the trigger input to the start of measurement.	0.0

6-2-2 Setting Parameters

Parameter settings can be set in either of the following two ways:

- How to set in the start navigation of project creation
- How to set on the device setting screen after project creation

The following shows the setting method on the device setting screen. For details on how to set it in the project creation procedure, refer to *Procedure for Setting IP Address (when necessary, further parameters)* on page 4-28.



If the parameter setting during project creation is not completed, set the parameters of each K6CM device according to the actual system configuration via the hub.

Because each K6CM device already has an IP address, you can access multiple forms K6CM via the hub from the software tool.

It depends on the following procedure.

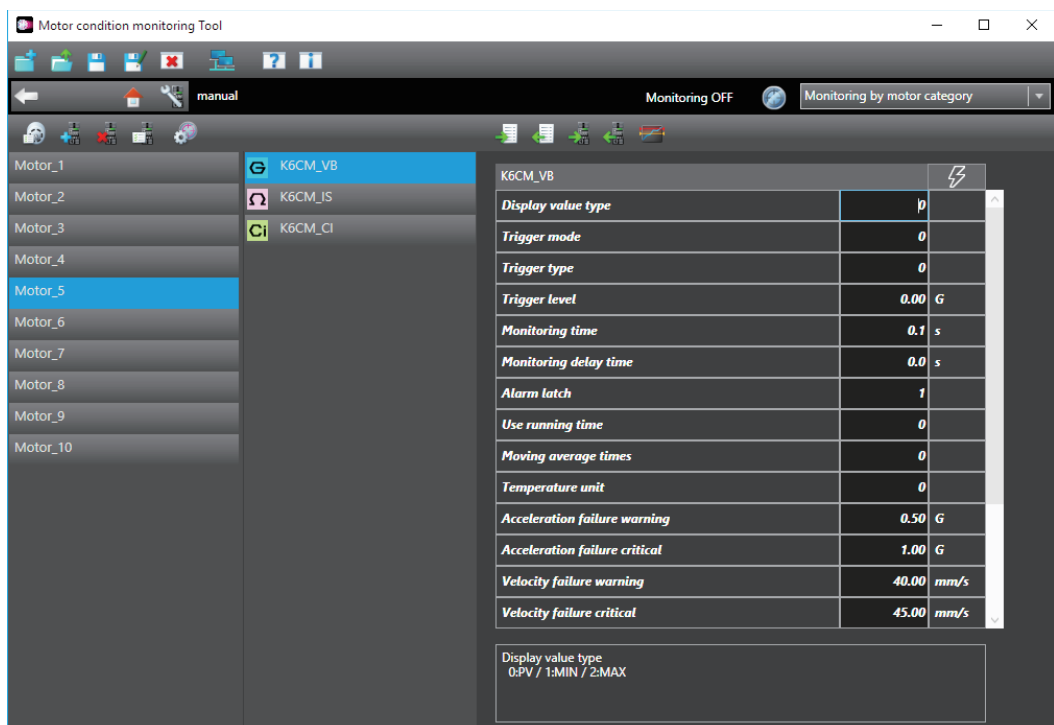
- 1 Connect the software tool to the K6CM.
- 2 Click the  [Device setting] Button.
The following device setting screen is displayed.



- 3 Select the device whose settings you want to change.
- 4 Set the parameters. (For details, refer to *6-2 Setting of K6CM Devices* on page 6-19.)
- 5 Click the  [Downloading (PC→device)] Button to write the parameters.
- 6 Click the  [Device reset] Button on the upper right of the parameter list on the device setting screen.

**Precautions for Correct Use**

After downloading the parameters to the device, turn the power of the K6CM ON again, or click the  [Device reset] Button at the upper right of the parameter list on the device setting screen in order to validate the parameter setting. With downloading, the parameter setting will not be effective.

6-2-3 Add a Device to an Existing Project

If you want to add a device on the project, perform the following operations.

After adding the device, connect with the factory default IP address and change its IP address.

- 1 Click the  [Add device] Button on the setting screen tool button. The following [K6CM Configuration setting] Dialog Box is displayed.

K6CM Configuration setting
Device is added to the project.

Motor name
Motor name Motor_1



Device type
Device type K6CM_VB

IP Address

IP Address 192.168.250.10
Sub-net mask 255.255.255.0
Default gateway .0.0.0

Add End

IP Address of the PC (IP Address for the device network setting) [192.168.250.1]
IP Address of the registered device

Motor name	 K6CM_VB	 K6CM_IS	 K6CM_CI
Motor_1	192.168.250.10	192.168.250.11	Unregistered
Motor_2	192.168.250.20	Unregistered	192.168.250.22
Motor_3	192.168.250.30	Unregistered	Unregistered

- 2 In the [Motor name], select the motor name to which the device belongs.

**Precautions for Correct Use**

- It is not possible to register the same type of device in the same motor (device group) name.
- Up to 3 devices can be registered in the same motor (device group) name.

- 3 Select the device type in the [Device type].
- 4 Enter the factory default IP address "192.168.250.10" in the [IP Address].
- 5 Click the [Add] Button.
- 6 Click the [End] Button.

- 7 Select the added device, click the  [Device setting] Button on the setting screen tool button. The following [K6CM Configuration setting] Dialog Box is displayed.



K6CM Configuration setting
Set IP address

IP Address

IP Address
Sub-net mask
Default gateway

OK Cancel

IP Address of the PC (IP Address for the device network setting) [192.168.250.1]
IP Address of the registered device

Motor name	 K6CM_VB	 K6CM_IS	 K6CM_CI
Motor_1	192.168.250.10	192.168.250.11	Unregistered
Motor_2	192.168.250.20	Unregistered	192.168.250.22
Motor_3	192.168.250.30	Unregistered	Unregistered

- 8 Change the IP address from the factory default value. Change the subnet mask and default gateway as necessary. It is recommended that you write the changed IP address on the IP address label.



- 9 Click the [OK] Button. The IP address setting on the project is changed, and the IP address of the actual device is automatically changed from the factory default value at the same time.

6-2-4 Motor (Device Group) Rename

To change the name of the motor (device group) on the project, execute the following operation.

- 1 In the Device setting screen, left click on the position of the motor name and change it.

6-2-5 Save Overwriting Project

To overwrite and save the project, do the following operations.

- 1 Click the  [Save Project] Button on the menu tool button. The following dialog box will be displayed.

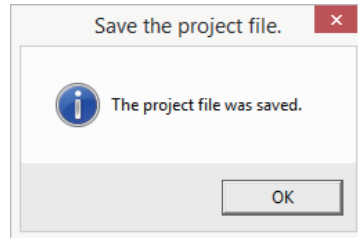

Note To save as a name, click  [Save the project as the specified name] of the menu tool button.

- 2 Click the [OK] Button. At this time, the log file is automatically saved with the project file.

6-2-6 Exit Project

To terminate the project, do the following. At this time, select whether to save the log file and project file.

- 1 Click the  [Close] Button at the top right of the screen. The following dialog box will be displayed.

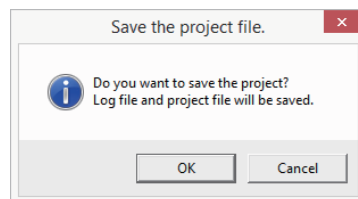

- 2 To save the log file and project file, click the [OK] Button. If you do not want to save, click the [Cancel] Button.
- 3 Enter the directory and project name and click the [Save] Button. The following dialog box will be displayed.

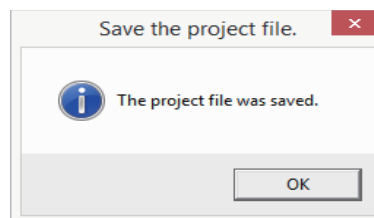

- 4 Click the [OK] Button. The following dialog box will be displayed.

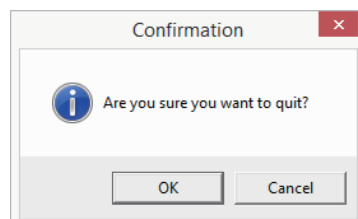

- 5 Click the [OK] Button. The software tool ends.



Monitoring with K6CM and Motor condition monitoring Tool

This section describes the motor monitoring and operation method using the K6CM devices and Motor condition monitoring Tool (Software Tool).

7-1	Motor Monitoring and Operation Procedure	7-2
7-2	Motor Monitoring Using the K6CM devices	7-3
7-2-1	Start measurement	7-3
7-2-2	Monitoring Type Switching	7-5
7-2-3	Monitoring method	7-6
7-2-4	Monitoring Completed	7-8
7-3	Motor Monitoring Using Software Tools	7-9
7-3-1	Monitoring Procedure with Motor Condition Monitoring Tool	7-9
7-3-2	Set the Monitoring Cycle	7-9
7-3-3	Start Monitoring	7-10
7-3-4	Saving Log Files	7-11
7-3-5	Graph Vertical Axis Scale Setting	7-12
7-3-6	Graph Time Axis Movement	7-13

7-1 Motor Monitoring and Operation Procedure

This section describes the monitoring and operating the motor using the K6CM.

Monitoring of the motor using the K6CM can be performed by simple monitoring with the K6CM devices only, monitoring with the software tool, or monitoring using the PCs or PLCs with the EtherNet/IP communications.

It is generally difficult to set the alarm setting (threshold) of the K6CM at the time of start of use.

Therefore, the actual motor monitoring and operation method depends on the following procedure.

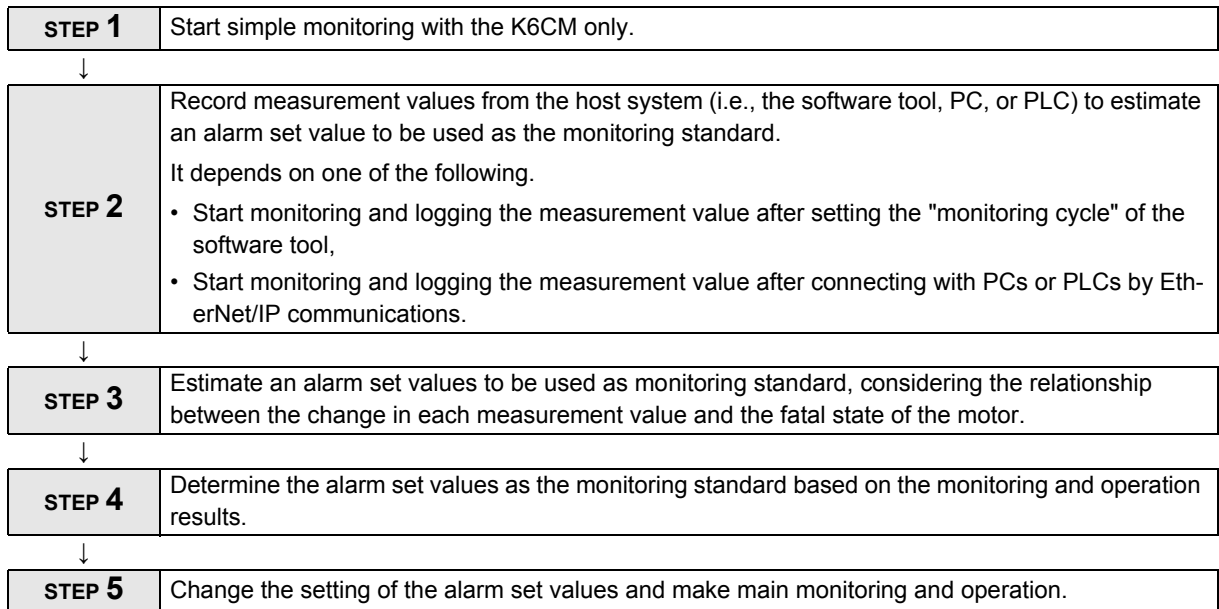

Section 7 describes simple monitoring with the K6CM devices only and monitoring using software tool.

Section 8 describes monitoring using PCs or PLCs with EtherNet/IP communications.

7-2 Motor Monitoring Using the K6CM devices

This section describes how to monitor with the K6CM devices.

7-2-1 Start measurement

- 1 Turn ON the power of the K6CM device. Depending on the "Trigger mode" and "Trigger type" set in advance in the parameter, the state of the K6CM device while power is ON will differ as follows.

Trigger mode	State of the K6CM device while power is ON	Status of the K6CM device		
		Numeric display LCD on the front	"MON" of the state display	Measuring and monitoring
Free run (while power is ON)		Measurement value displayed	Lit.	Executed
External trigger	When condition is not met	"- - -" displayed	Not lit.	Not executed
	When condition is met	Measurement value displayed	Lit.	Executed
Internal trigger	When condition is not met	"- - -" displayed	Not lit.	Not executed
	When condition is met	Measurement value displayed	Lit.	Executed

- Note 1. When an input exceeds the input range, 7 segments will blink.
2. "- - -" is displayed even when monitoring conditions are met until the measurement value is calculated from the time of power ON.

Measurement start and end conditions are as follows.

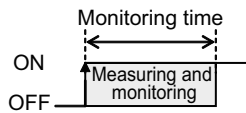
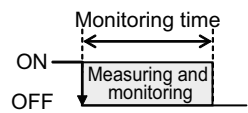
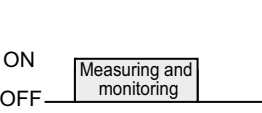
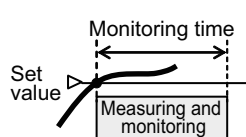
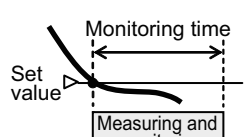
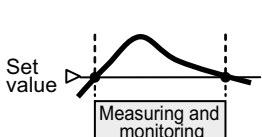
Trigger mode	Start condition of measuring and monitoring	Trigger type			
		Rising edge	Falling edge	Level	
Free run (while power is ON)	All times after turning ON the power of the K6CM device	Always measuring			
External trigger	Depends on the status of the external input				
		• Start condition	When external input changes from OFF to ON	When external input changes from ON to OFF	While the external input is in the ON state
		• End condition	After the monitoring time has elapsed	After the monitoring time has elapsed	The external input is OFF
Internal trigger	Depends on the relationship between the measurement value and the set value (trigger level)				
		• Start condition	When the measurement value exceeds the set value (trigger level)	When the measurement value falls below the set value (trigger level)	While the measurement value exceeds the set value (trigger level)
		• End condition	After the monitoring time has elapsed	After the monitoring time has elapsed	Note : For the insulation resistance, this is while present value falls below the set value.

- 2** When the trigger mode is "Free run (while power is ON)", measuring and monitoring will be started.

Measurement value is displayed on the numeric display LCD on the front of the device. At the same time, "MON" of the state display on the front of the device gets lit.

- When the trigger mode is "external trigger", operate the external input.
- When the trigger mode is "internal trigger", wait until the state of the measurement value becomes the start condition of measuring and monitoring.

- 3** When measuring and monitoring are started after the power is turned ON, the numeric display LCD in the front of the device switches from "- - - -" to the measurement value display. At the same time, "MON" of the state display on the front of the device gets lit.

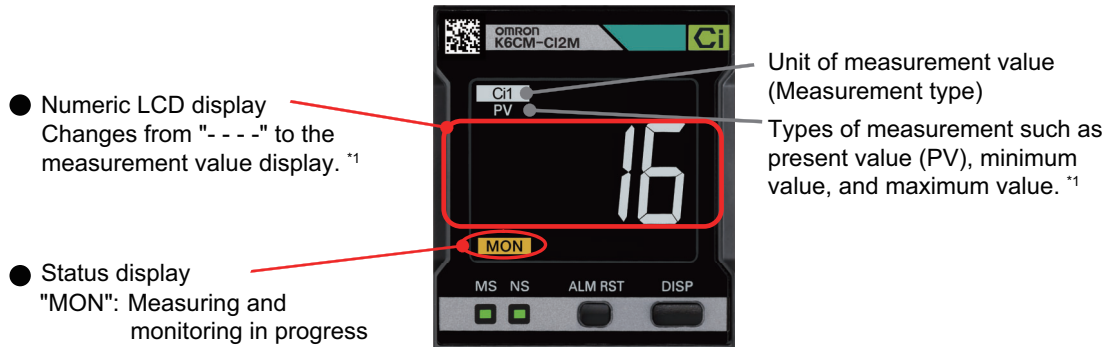

*1. In the factory default, "PV" is lit as the type of measurement such as present value, minimum value, and maximum value. The numerical display shows "present value". When "Display value type" is set to "Minimum value" or "Maximum value" with the software tool or message communications, "MAX" or "MIN" is lit as "Each type of present value (PV), minimum value, maximum value of measurement value", and the numerical display shows "Minimum value" or "Maximum value".

7-2-2 Monitoring Type Switching

- 1 Switch the monitoring category by pressing the [DISP] key on the front of the device. Each time you press the [DISP] key, the unit of the measurement value (monitoring category) changes.

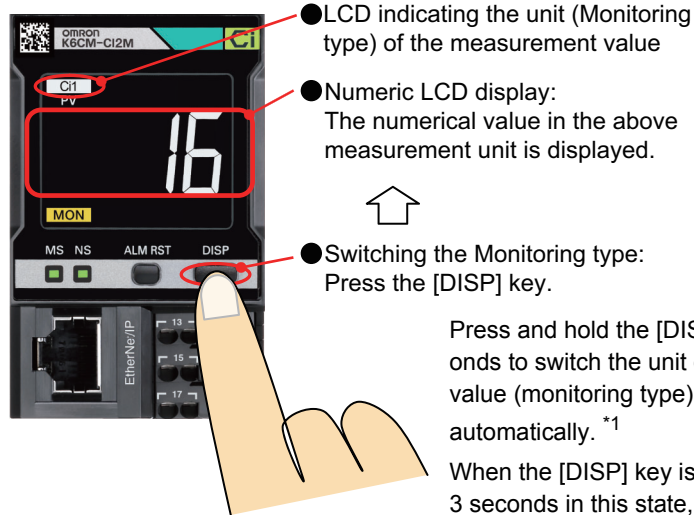

*1. Display auto switching mode can be used in Eip cpu version 1.20 or later.

Monitor Type	LCD indicating the unit of measurement value	Monitoring category
Comprehensive current diagnosis type	"Ci1" ←	Degradation level 1
	↓	
	"Ci2"	Degradation level 2
Vibration & temperature type	↓	
	"A" ←	Current
	↓	
	"G" ←	Acceleration
Insulation resistance type	↓	
	"mm/s"	Velocity
	↓	
	"T" ←	Motor temperature
Insulation resistance type	↓	
	"ΔT" ←	Temperature gap (i.e., the difference from the room temperature of the motor temperature)
	↓	
Insulation resistance type	"MΩ" ←	Insulation resistance
	↓	
	"mA" ←	Leakage current

7-2-3 Monitoring method

When monitoring with the K6CM devices, it can be monitored by the following method.

- Front alarm bar
- Transistor output

Monitor with the Front Alarm Bar

When monitoring with front alarm bar, the following monitoring is available.

Front alarm bar	Status display	Status	Meaning	
Not lit.	Not lit.	Measuring and monitoring Not yet	When using the trigger function (external trigger or internal trigger), measuring and monitoring are not started yet after the power is turned ON.	
Green	"MON" lit	Comprehensive alarm: normal	All measurement values are in normal condition.	At the end of measuring and monitoring, the display of the front alarm bar is retained (only when using the trigger function).
Yellow		Comprehensive alarm: Warning	There is no "critical" in the measurement value, There is "warning" even if at least one state.	
Red		Comprehensive alarm: Critical	There is "critical" in even one measurement value.	
Not lit.	"ERR" lit	When the self-diagnosis error occurs	Self diagnostic error is occurring.	

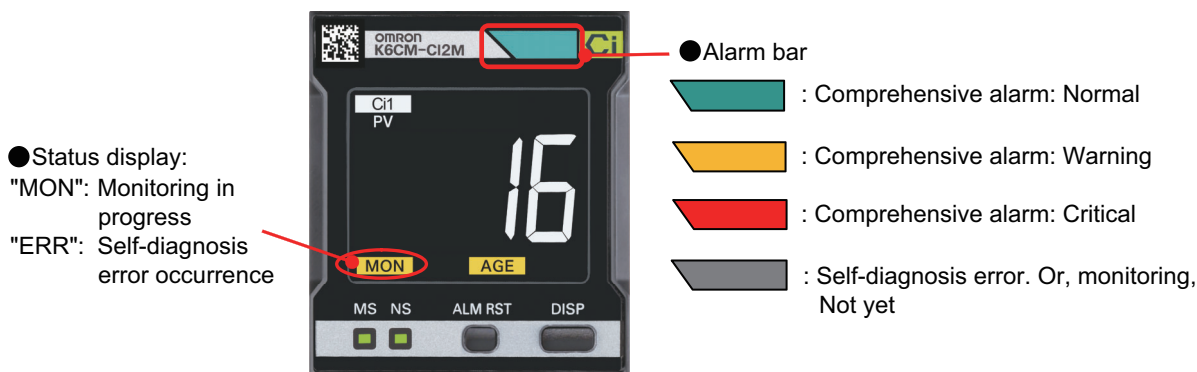

Monitor with the Transistor Outputs

When monitoring with the transistor outputs, the following monitoring is available.

Transistor Output 1	Transistor Output 2	Transistor Output 3	Status display	Status	Meaning	
OFF*1	OFF*1	ON	Not lit.*2	Monitoring Not yet	In the case of a trigger, monitoring is not started yet after the power is turned ON.	
ON*1	ON*1	ON	"MON"	Comprehensive alarm: normal	All measurement values are in normal condition.	At the end of monitoring, the state of transistor outputs 1 and 2 are retained (only when using the trigger function). "MON" will go out at this time.
OFF*1	ON*1	ON		Comprehensive alarm: Warning	There is no "critical" in the measurement value, There is "warning" even if at least one state.	
OFF*1	OFF*1	ON		Comprehensive alarm: Critical	There is "critical" in even one measurement value.	
OFF	OFF	OFF	"ERR"	When the self-diagnosis error occurs	Self diagnostic error is occurring.	

*1. This is the output result when "Transistor output method" is set to "Normally Close". By default, it is set to "Normally Close". By setting it to "Normally Open" with the software tool or message communications, ON/OFF can be reversed.

*2. When the trigger mode is "Free run", "MON" lights up.

● Status display:
 "MON": Monitoring in progress
 "ERR": Self-diagnosis error occurrence

Terminal	Meaning	Operation
Transistor Output 1 (+)	Warning output of comprehensive alarm. Transistor output method can be set to Normally Close or Normally Open.	In the case that the transistor type is Normally Close, ON: Comprehensive alarm is normal OFF: Comprehensive alarm is warning or critical In the case that the transistor type is Normally open, ON: Comprehensive alarm is warning or critical OFF: Comprehensive alarm is normal (* 3)
Transistor Output 1 (-)		
Transistor Output 2 (+)	Critical output of comprehensive alarm. Transistor output method can be set to Normally Close or Normally Open.	In the case that the transistor type is Normally Close, ON: Comprehensive alarm is normal OFF: Comprehensive alarm is warning or critical In the case that the transistor type is Normally open, ON: Comprehensive alarm is warning or critical OFF: Comprehensive alarm is normal (* 3)
Transistor Output 2 (-)		
Transistor Output 3 (+)	Self-diagnosis error output. Transistor output method is Normally Close, and can not be changed.	In the following cases, ON When self-diagnosis error does not occur In the following cases, OFF When self-diagnosis error occurs
Transistor Output 3 (-)		

*3. In either of the following cases, the transistor output turns OFF regardless of the transistor output method.

- Monitoring is not performed (only when using the trigger function)
- Self-diagnosis error occurrence

In addition, transistor output state (ON/OFF) is held at the end of monitoring (only when using the trigger function)

7-2-4 Monitoring Completed

When the trigger mode is "external trigger" or "internal trigger", when the termination condition of monitoring is satisfied, the measurement value of the numerical display LCD on the front of the K6CM is retained. Also, the status at the end of monitoring is retained for the alarm bar and transistor outputs 1 and 2.

At this time, "MON" in the status display on the front of the K6CM goes out.

7-3 Motor Monitoring Using Software Tools

This section describes how to monitor a motor using the software tools.

7-3-1 Monitoring Procedure with Motor Condition Monitoring Tool

It depends on the following procedure.

- 1 Click the  [Monitoring setting] Button and set "Monitoring cycle".
- 2 In the upper right corner of the screen, select [Monitoring by motor category] or [Monitoring by monitoring category] from the pulldown list.
- 3 Monitoring is performed on the [Monitoring by motor category] screen or [Monitoring by monitoring category] screen.



Precautions for Correct Use

In order to monitor the K6CM with the software tool, the communications service of the SYSMAC Gateway communications driver between the computer and the K6CM must be in the start status.

The status of SYSMAC Gateway's communications service can be checked on the SYSMAC Gateway Console screen.

The SYSMAC Gateway Console screen is activated by clicking [Device setting] on the startup screen or by clicking the [SYSMAC Gateway Console] Button on the monitoring screen.

7-3-2 Set the Monitoring Cycle

Click the  [Monitoring setting] Button.

Set Monitoring cycle on the following screen.

The settable range is 5 to 99999 seconds. The default value is 600 seconds (10 minutes).

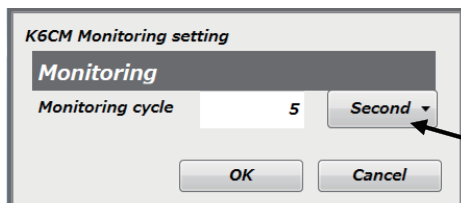

Using this pull down list allows you to change the unit of monitoring cycle. Selectable units are seconds, minutes, hours, and days.



Version Information

With software tool version 1.2.0.0 or later, the unit of monitoring cycle can be set.

7-3-3 Start Monitoring

Click the  [Start monitoring] Button.

Monitoring with the software tool is started.

There are a method of monitoring by motor (K6CM device group) and a method of monitoring by monitoring category.

Monitoring by motor (K6CM device group)

When monitoring by motor (K6CM device group), confirm the detailed information in the following order.

- Monitor screen by motor

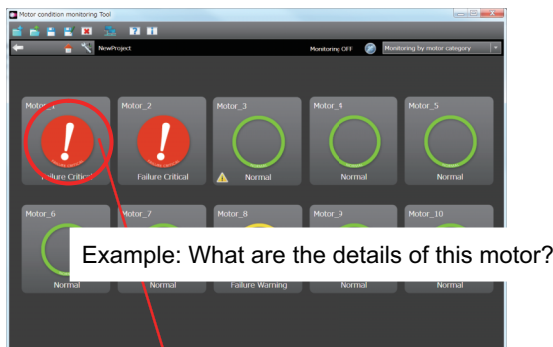

- Detailed status screen by motor (bar display)

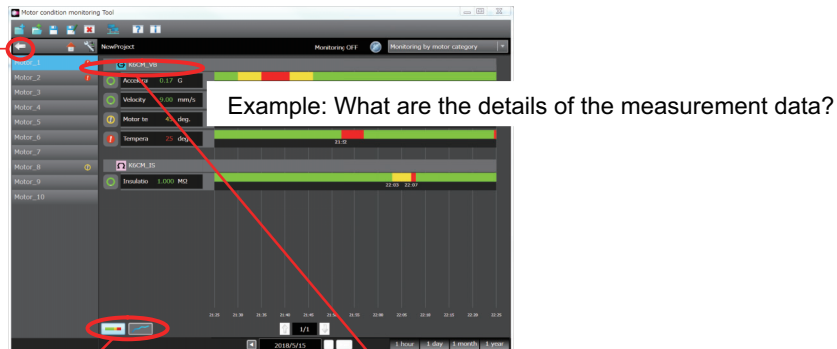

- Detailed data screen by motor category



The time series period can be switched to 1 hour / 1 day / 1 month / 1 year.

If a period of more than 1 day is selected and displayed, data may be thinned out and displayed.

Monitoring by monitoring category

When monitoring by monitoring category, confirm the detailed information in the following order.

● Monitoring screen by monitoring category



● Detailed status screen by monitoring category

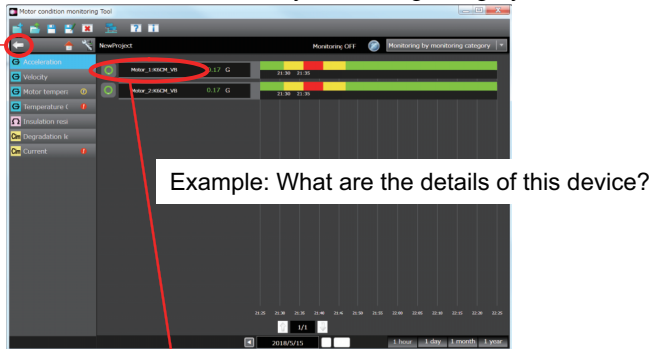

● Detailed data screen by monitoring category



7-3-4 Saving Log Files

The log file is saved in the following cases.

- When to press the [Save Project] Button to save the project
 - Every hour during monitoring
 - When to complete monitoring
 - When to select "Save log file and project file" at the end of the software tool
- * Project files are also saved at the same time.

7-3-5 Graph Vertical Axis Scale Setting

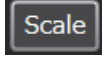
Click the  Button on each graph display screen.

Make the settings on the following screen. The vertical axis scale can be set for each measurement value of each K6CM.

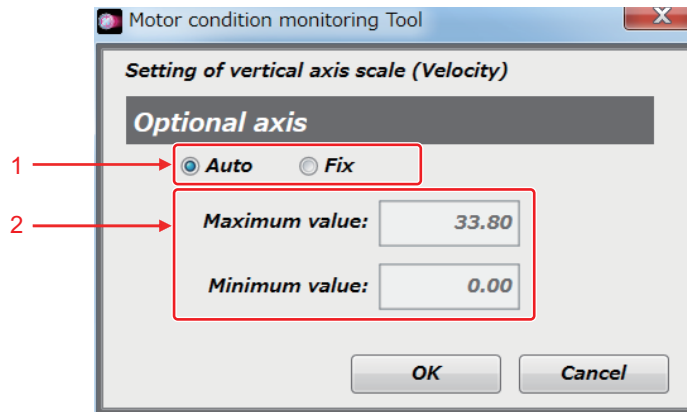

No.	Name	Description
1	Auto or Fix select Button	Auto: The vertical axis scale of the graph changes automatically. 0 to 1.3 times (^{*1}) of the larger of the measurement value or alarm value (Warning/Critical) Fix: The vertical axis scale of the graph is the value entered in the Max./min. value column.
2	Max./min. value column	When "Fix" is selected, enter the scale maximum value and minimum value. The maximum value must be greater than 10 digits (^{*2}) than the minimum value.

*1. When the measurement value is the insulation resistance value, it is fixed from 0 to 1.000 MΩ.

*2. The "digit" represents the resolution. For example, if the resolution of the measurement value is in increments of 1, the maximum value must be greater than the minimum value by 10 or more. If the resolution of the measurement value is 0.1 increments, the maximum value must be at least 1.0 greater than the minimum value.



Version Information

With software tool version 1.2.0.0 or later, the vertical axis scale can be set.

In earlier versions, the vertical axis scale of the graph changes automatically.

7-3-6 Graph Time Axis Movement

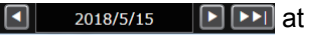
You can move the graph to be displayed in the time axis direction in section  at the bottom of the graph display screen.

The operation of each button and display column is as follows.

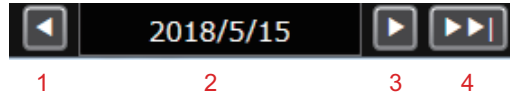

No.	Name	Description
1	Back Button	When you click this button, the graph of the half-page new date and time is displayed rather than the graph being displayed. The time axis movement width becomes half of the displayed graph range.
2	Display of graph display year date and time	Displays the year, month, day of the right end of the graph being displayed.
3	Refresh Button	When you click this button, the graph of the half-page new date and time is displayed rather than the displayed graph. The time axis movement width becomes half of the displayed graph range.
4	Refresh Button	Click this button to display the graph of the latest date and time. If the latest graph is displayed, the button operation will be invalid.



Version Information

With software tool version 1.2.0.0 or later, the graph time axis movement is available.

8

Monitoring and Setting Using the EtherNet/IP Devices

K6CM devices can also be monitored using EtherNet/IP compatible devices. This section describes how to monitor using the EtherNet/IP.

8-1 Overview	8-2
8-1-1 What is Monitoring Using EtherNet/IP?	8-2
8-1-2 EtherNet/IP Communications Specifications	8-4
8-2 Monitoring Using the Tag Data Link	8-5
8-2-1 Connection setting	8-5
8-2-2 Data to be Tag Data Link Target in the K6CM Device	8-9
8-3 Monitoring and Setting Using the CIP Message Communications and Examples of Communications Instructions	8-12
8-3-1 Datatype List of Variables	8-12
8-3-2 Services Supported by Objects in K6CM	8-12
8-3-3 Monitor Object (Class ID: 370 hex)	8-13
8-3-4 Setting Object (Class ID: 371 hex)	8-18
8-3-5 Identity Object (Class ID: 01 hex)	8-24
8-3-6 TCP/IP Interface Object (Class ID: F5 hex)	8-26
8-3-7 Examples of CIP Message Communications Instruction	8-28
8-4 Sample Program for the NJ/NX-series	8-30
8-4-1 Sample Program Overview	8-30
8-4-2 Sample Program Processing Flow and Function Block Specifications	8-33
8-4-3 Sample Program Execution Procedures	8-39
8-4-4 Sample Program Code Descriptions	8-40

8-1 Overview

8-1-1 What is Monitoring Using EtherNet/IP?

The K6CM device can communicate with a PLC that supports EtherNet/IP or commercially available PC software.

EtherNet/IP has the following two types of communications methods.

Communications method	Outline	For the K6CM devices	
		Monitoring	Settings
Tag data link	Multiple data such as measurement values can be monitored without using a communications program. For data that can be monitored, refer to "8-2-2 Data to be Tag Data Link Target in the K6CM Device on page 8-9".	Supported	Not supported
CIP message communications	Individual data such as measurement values can be read and written by using communications program. It can also be used during tag data link.	Supported	Supported

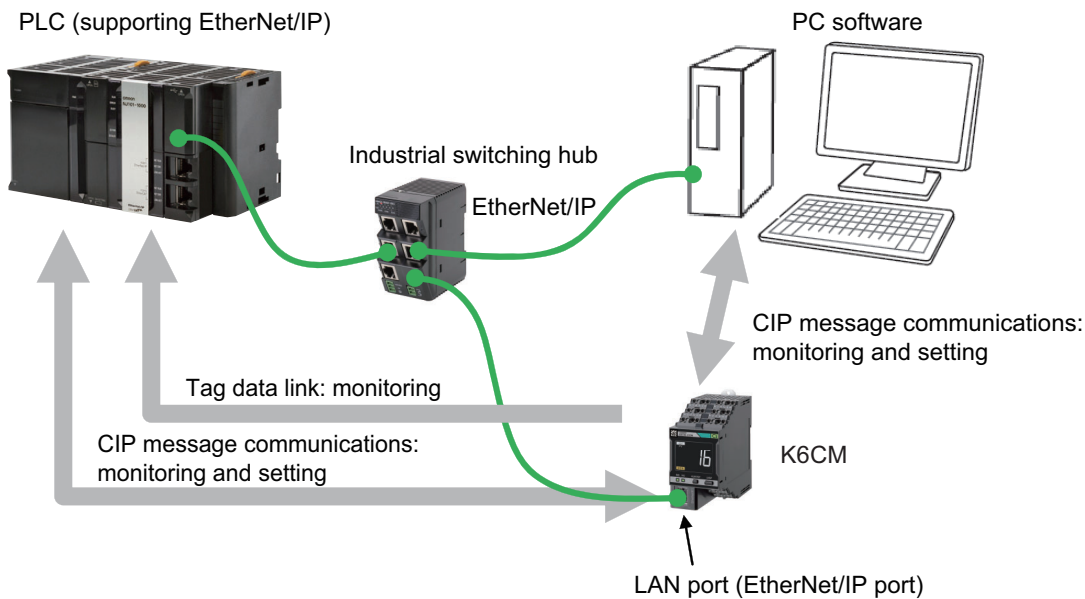

If the K6CM device was manufactured before April 30, 2019, a tag data link timeout may occur in the network system including the node configured for multicast communications. Use a switching hub with multicast filtering function to prevent multicast packets from reaching the K6CM devices.

The date of manufacturing can be checked by the lot number. The lot number is indicated on the label of the individual box.

How to read the lot number on the label.

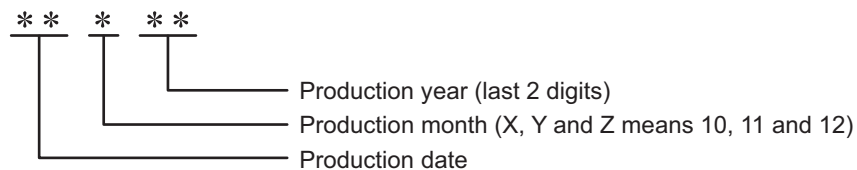

You can check if the product was manufactured before April 30, 2019 with the Eip cpu version.

April 30, 2019 or before: version 1.11

May 1, 2019 or after: version 1.12

You can check the Eip cpu version by reading it using the software tool or EtherNet/IP communications.

For other checking methods, contact your OMRON representative.

Tag Data Link

Multiple data such as measurement values of the K6CM devices are periodically sent to the specified area of the PLC.

- PLC-side input tag set
The PLC assigns I/O memory address or variables to the input tag set. The data size is fixed to 44 bytes (the internal data size of the K6CM).
- K6CM-side output tag set
The K6CM device assigns the instance ID of the internal data to be tagged data link. The data size is fixed at 44 bytes.

● Configuration tool

When configuring with OMRON controllers, the following setting tools for the tag data link should be used.

Device	Configuration tool
CS/CJ-series	Network Configurator
NJ/NX-series	Network Configurator or Sysmac Studio

CIP Message Communications

A CIP client such as the NJ/NX-series issues any CIP command in the Explicit message to the K6CM devices. This allows you to read and write all the data of the K6CM device.

● Communications Instructions

When sending a CIP command with Explicit messages from OMRON PLCs or Controllers, use the following communications Instruction.

Device	Communications Instructions
CS/CJ-series	Explicit message send commands (2810 hex) for CIP routing are issued by CMND instructions
NJ/NX-series	CIPSend (Send Explicit Message Class 3) instruction Or CIPUCMMSend (Send Explicit Message UCMM) instruction

8-1-2 EtherNet/IP Communications Specifications

Item		Specifications	
Tag data link	Class1	Supported.	
	Connection resource	1	
	Number of connected nodes	1	
	Number of tag sets	1	
	Packet interval (RPI)	250 ms to 10000 ms (default: 250 ms)	
	Timeout value	Multiples of RPI (4 times, 8 times, 16 times, ... , and 512 times)	
	Connection type	Point To Point Connection (fixed)	
	Communications Specifications	Type Port number	UDP 2222
Explicit Message	Class 3	Supported.	
	UCMM	Supported.	
	Connection resource	2 (Class 3 server)	
	Number of clients that can communicate at one time with UCMM	2	
	Communications Specifications	Type Port number	TCP 44818
	Conformance	EtherNet/IP conformance test	Conforms to CT17

8-2 Monitoring Using the Tag Data Link

8-2-1 Connection setting

Setting items		Setting contents
Originator device (PLC)	Input tag set	Specify the tag set on the PLC side of 44 bytes. *1
	Connection type	Specify "Point to Point connection".
Target device (K6CM device)	Output tag set	Instance ID: 100, size is fixed to 44 bytes.
Packet interval (RPI)		250 ms to 10000 ms (default: 250 ms)
Timeout value		Multiples of RPI (4 times, 8 times, 16 times, ..., 512 times)

*1. Create tag set of PLC side with size of 44 bytes.



Precautions for Correct Use

If I/O memory addresses are specified for the communications areas, the information in the communications areas will be cleared when the operating mode of the PLC changes unless addresses in the Area, which are maintained, are specified.

The connection setting method of "Using the CS/CJ-series" and "Using the NJ/NX-series" is shown below. For detailed setting procedure, refer to *A-9 Tag Data Link Connection Setting Procedures* on page A-26.

- Using the CS/CJ-series

For detailed information on the Network Configurator, refer to the following manual.
CS/CJ Series EtherNet/IP Units Operation Manual (Cat. No.W465)

1 Install and start

- Install Network Configurator.
- Start Network Configurator.
- Download the K6CM EDS file from our I-Web and install it on the Network Configurator. Register the CIP revision corresponding to the EIP version on the side label of the K6CM device.

EIP version	CIP revision	
	Major revision	Revision on the Hardware list
Ver. 1.0	1	Rev 1
Ver. 1.1	2	Rev 2
Ver. 1.2	3	Rev 3

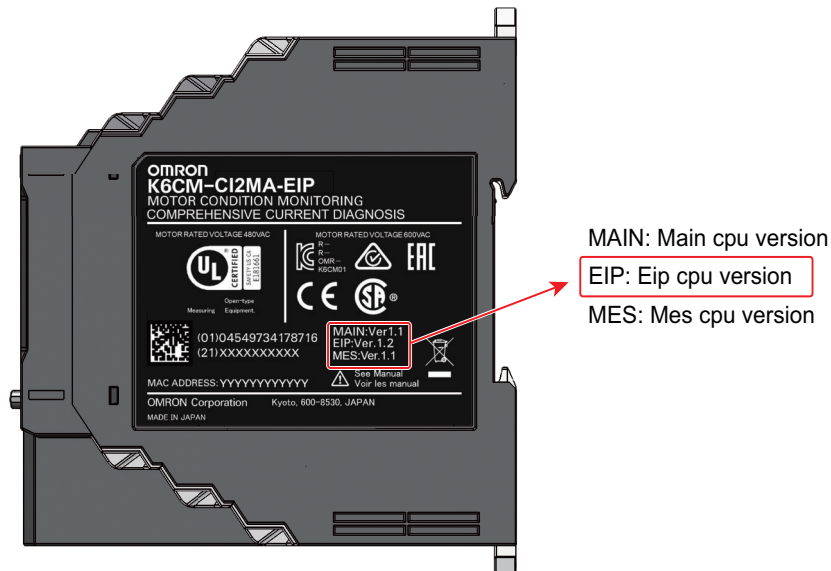

2 Configuration

- Register PLC and K6CM devices in the network configuration and set the IP address.
- Configure settings to add a connection between devices (Make a connection).

Note Things to check beforehand:

- Which memory area (I/O memory or variables) in the PLC should be used for the tag data link.
- The size of the internal data (parameter) of the K6CM is 44 bytes for all models.
 - 2)-1 Drag a K6CM to the PLC and register it.
 - 2)-2 Click the [Edit Tag Sets] Button to create input tags with the above sizes.
 - 2)-3 Register the input tag as it is as input tag set.
 - 2)-4 Select the input tag set created in 2) -3 above from the pull-down list.
 - 2)-5 Register the connection.

Connection assignment dialog to K6CM

Select the 44-byte tag set you created

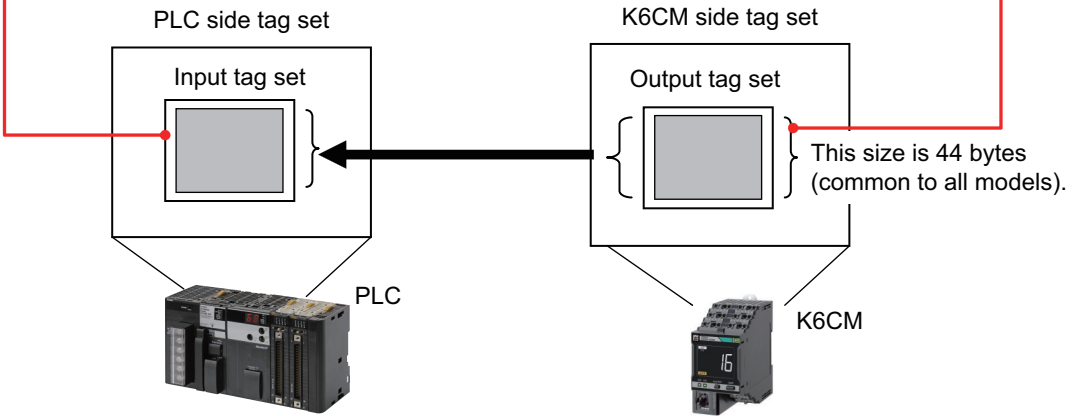
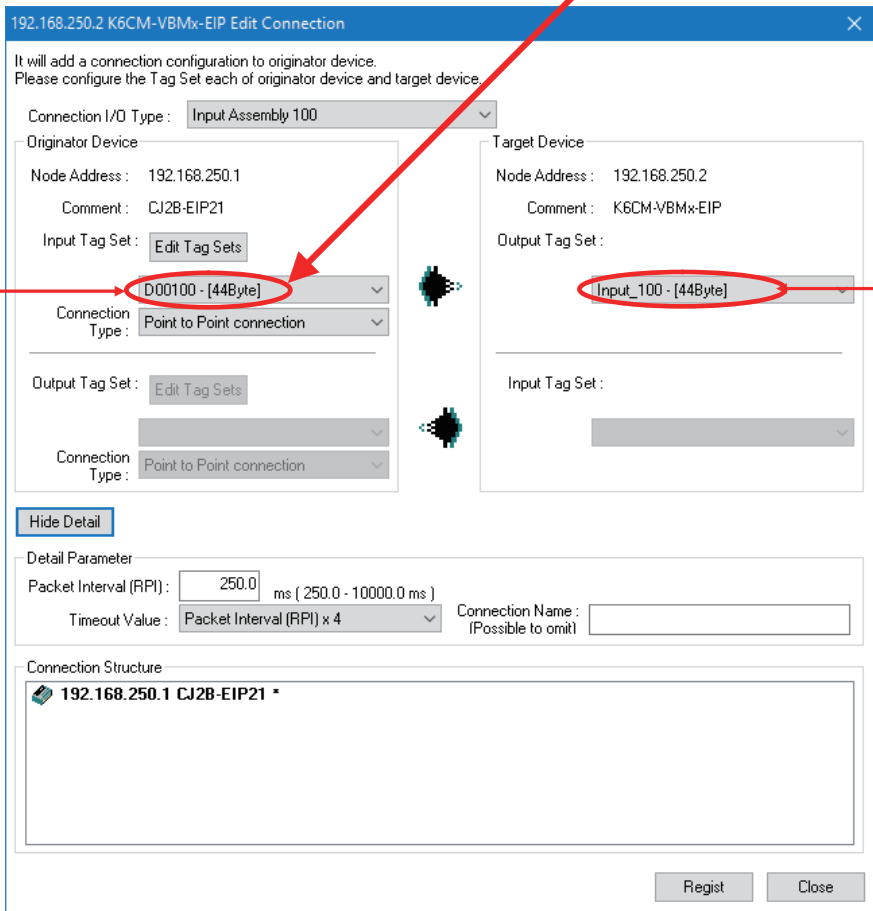

Create a tag that matches the size of the internal data of type K6CM 44 bytes (common to all models), and sets it as the input tag set as it is.

Leave the output tag set name "Input_100 - [44 Bytes]" displayed.

- 3** Download the connections that were set to the PLC. Tag data link communications are automatically started.
- 4** Confirm each LED of the PLC and the K6CM devices, and status information in the [Device Monitor] Dialog Box of the Network Configurator.

- Using the NJ/NX-series

For detailed information on the Sysmac Studio, refer to the following manual. *NJ/NX-series CPU Unit Built-in EtherNet/IP Port User's Manual* (Cat. No. W506)

- 1** Select [EtherNet/IP connection settings] from the [Tools] menu.
- 2** Right-click on the target device list in the tool box on the displayed Tab page and select the [Display EDS Library] menu.
- 3** Click the [Install] Button and import the EDS file of each K6CM device in the [EDS Library] Dialog Box.
- 4** Click  [Add device] Button in [Toolbox] and select the K6CM device in the [Built-in EtherNet/IP Port Settings Connection] Tab page.
- 5** Select the K6CM that has been added from the pull-down list in the [Target Device] column in "▼Connection" list in the Connection Tab Page of PLC side (i.e., originator side).
- 6** In the [Target Variable] column, press the [Ctrl] and [Space] keys at the same time and the available identification numbers are displayed on the pull down list, so select the identification number to use.

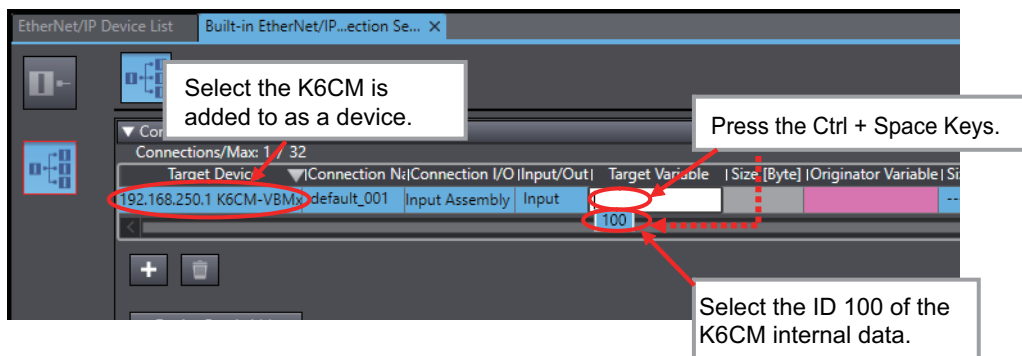

When you select an identification number, the size is automatically entered synchronously.

- 7** In the [Originator Variable] column, select the global variable of the NJ/NX-series CPU Unit. (Beforehand, it is necessary to register global variables whose network publish attribute is "Input" or "Output" in the global variable table.)

8-2-2 Data to be Tag Data Link Target in the K6CM Device

Identification Number and Size of Internal Data to be Tag Data Link

The identification number (the instance ID of the Assembly object) and the size of internal data (Assembly object) to be tag data link target in the K6CM device are as follows.

Identification number (Instance ID of Assembly object)	Size	Direction of data
100	44 bytes common to all models	Target (K6CM type) → Originator (such as PLC)

List of Internal Data to be Tag Data Link

The tag data link target data in the K6CM device is shown below.

For each K6CM device, it is as follows.

For detailed information on each data, refer to *A-6 Internal Data of K6CM Devices* on page A-14.

In both cases, it is possible to read from the K6CM device to the originator such as PLC.

All data is one word.

Word	Model	Comprehensive current diagnosis type	Vibration & temperature type	Insulation resistance type
		K6CM-CI2M	K6CM-VBM	K6CM-ISM
+0		Mes cpu version		
+1		Main cpu version		
+2		Eip cpu version		
+3		Main body status *1		
+4		Running Time		
+5		Number of triggers		
+6		Current status *2	Acceleration status *2	Insulation resistance status *2
+7		Current pv	Velocity pv	Insulation resistance pv
+8		Current min.	Acceleration min.	Insulation resistance min.
+9		Current max.	Acceleration max.	Insulation resistance max.
+10		Degradation level 1 status *2	Velocity status *2	I0r status *2
+11		Degradation level 1 pv	Velocity pv	I0r pv
+12		Degradation level 1 min.	Velocity min.	I0r min.
+13		Degradation level 1 max.	Velocity max.	I0r max.
+14		Degradation level 2 status *2	Motor temperature status *2	I0c status
+15		Degradation level 2 pv	Motor temperature pv	I0c pv
+16		Degradation level 2 min.	Motor temperature min.	
+17		Degradation level 2 max.	Motor temperature max.	
+18			Temperature gap status *2	
+19			Temperature gap pv	
+20			Temperature gap min.	
+21			Temperature gap max.	

*1. Main body status

The Main body status is handled as 2-byte data consisting of bit data in the table.

Example: Tr1 to Tr3 are "ON" and the measurement state is "During monitoring".

The 15th, 14th, 13th and 9th bits are all "1", so it is "1110 0010 0000 0000" in binary notation and "200" in hexadecimal notation. In the log file (CSV) of the Motor condition monitoring Tool, the Main body status is in hexadecimal notation.

Bit position	Status	Bit contents	
		0	1
00	Mes cpu error	Not occurred	Occurrence
01	Mes cpu data flash error	Not occurred	Occurrence
02	Main cpu error	Not occurred	Occurrence
03	Main cpu data flash error	Not occurred	Occurrence
04	Reserved area		
05	Reserved area		
06	Reserved area		
07	Reserved area		
08	Running Time status	Unreached	Reached
09	Monitoring condition	Monitoring is stopped	Monitoring
10	Reserved area		
11	Reserved area		
12	Trigger input	OFF	ON
13	Tr1 (transistor 1output state)	OFF	ON
14	Tr2 (transistor 2output state)	OFF	ON
15	Tr3 (transistor 3output state)	OFF	ON



Precautions for Correct Use

If the trigger function is used, when reading the measurement value with the tag data link, be sure to read it when the "Monitoring condition" bit (bit 09) of the Main body status is 1 (ON).

If reading is performed when the "Measurement state" bit is 0 (OFF), there is a possibility that the value before monitoring (i.e., 0) or the value held after monitoring is being read.

*2. Measurement status (common form of measurement values)

The measurement status is handled as 2-byte data consisting of bit data in the table.

Example: The individual alarm result (Warning) is "ON".

The 12th bit is "1", so it is "0001 0000 0000 0000" in binary notation and "1000" in hexadecimal notation.

In the log file (CSV) of the Motor condition monitoring tool, the Main body status is in hexadecimal notation.

Bit position	Status	Bit contents	
		0	1
00	Present value unmeasured state	Measured	Standby
01	Present value input error	Not occurred	Occurrence
02	Reserved area		
03	Reserved area		
04	Maximum value unmeasured state	Measured	Standby
05	Maximum value input error	Not occurred	Occurrence
06	Reserved area		
07	Reserved area		
08	Minimum value unmeasured state	Measured	Standby
09	Minimum value input error	Not occurred	Occurrence
10	Reserved area		
11	Reserved area		
12	Individual alarm result (Warning)	OFF	ON
13	Individual alarm result (Critical)	OFF	ON
14	Reserved area		
15	Reserved area		



Precautions for Correct Use

If the trigger mode is "Free run (no trigger)", read the data when "Present value not measured" bit (bit 00) of the measurement status is 0.

There is a possibility that the value before monitoring (i.e., 0) is being read.

8-3 Monitoring and Setting Using the CIP Message Communications and Examples of Communications Instructions

This section shows the contents of monitoring and setting using the CIP message communications and examples of communications instructions.

8-3-1 Datatype List of Variables

This section describes the data types of variables used in the CIP message communications.

Data type	Description
USINT	Unsigned 1 byte BIN
UINT	Unsigned 1 word BIN
UDINT	Unsigned 2 words BIN
BOOL	1 bit
SHORT_STRING	Data size (1 byte) + 1 byte character string
STRING	Data size (2 bytes) + 1 byte character string
WORD	1 word hex
DWORD	2 words hex

8-3-2 Services Supported by Objects in K6CM

The services supported by the objects in K6CM device are as follows.

Object name	Class ID	Contents
Monitor object	370 hex	Reading the measurement values and other present values (PV) of the K6CM.
Setting object	371 hex	Writing and reading the alarm setting values and other setting values of the K6CM.
Identity object	01 hex	Reading the identification information of the K6CM. Reading and resetting the state of the built-in EtherNet/IP port.
TCP/IP Interface object	F5 hex	Writing and reading of TCP/IP settings of the K6CM.

8-3-3 Monitor Object (Class ID: 370 hex)

This object reads the measurement value of K6CM device and other present values (PV).

Service Codes

Service code	Service name	Description	Supported services	
			Classes	Instances
01 hex	Get_Attributes_All	Reads the values of all attributes.	Not supported.	Supported.
0E hex	Get_Attribute_Single	Reads the value of the specified attribute.	Not supported.	Supported.

The data size is 44 bytes for Get_Attributes_All.

Class ID

Specify 370 hex.

Instance ID

Specify 01 hex.

Attribute ID

● Common to K6CM

Attribute ID	Parameter name	Description	Attribute	Data	
				Data type	Default value
64 hex	Mes cpu version	Measurement part version	Read	UINT	Product specific
65 hex	Main cpu version	Main part version	Read	UINT	Product specific
66 hex	Eip cpu version	EtherNet/IP part version	Read	UINT	Product specific
67 hex	Main body status	Displays the Main body status For details, refer to "Main body status". *1	Read	WORD	Depends on the condition.
68 hex	Running Time	Coefficient indicating lifetime of the K6CM device based on the product of operation time and internal temperature. 0000 to 0064 hex	Read	UINT	Depends on the condition.
69 hex	Number of triggers	Displays the total number of integration times of the trigger. Increase the number of triggers by +1 every 100 iterations of starting measuring and monitoring. 0 to 65535	Read	UINT	Depends on the condition.

69 hex or more: It depends on the K6CM model. Refer to the following and subsequent sections.

*1. Main body status

Bit position	Status	Bit contents	
		0	1
0	Mes cpu error	Not occurred	Occurrence
1	Mes cpu data flash error	Not occurred	Occurrence
2	Main cpu error	Not occurred	Occurrence
3	Main cpu data flash error	Not occurred	Occurrence
4	Reserved area		
5	Reserved area		
6	Reserved area		
7	Reserved area		
8	Running Time status	Unreached	Reached
9	Monitoring condition	Monitoring stopped	During monitoring
10	Reserved area		
11	Reserved area		
12	Trigger input	OFF	ON
13	Tr1 (transistor 1 output state)	OFF	ON
14	Tr2 (transistor 2 output state)	OFF	ON
15	Tr3 (transistor 3 output state)	OFF	ON



Precautions for Correct Use

If the trigger function is used, when reading the measurement value with the tag data link, be sure to read it when the "Monitoring condition" bit (bit 09) of the Main body status is 1 (ON).

If reading is performed when the "Measurement state" bit is 0 (OFF), there is a possibility that the value before monitoring (i.e., 0) or the value held after monitoring is being read.

● Comprehensive current diagnosis type (K6CM-CI2M)

Attribute ID	Parameter name	Description	Attribute	Data	
				Data type	Default value
6A hex	Current status	Displays the measurement status. For details, refer to "Measurement status (common form of measurement value)". *1	Read	UINT	Depends on the condition.
6B hex	Current pv	Measurement value of current pv	Read	UINT	* 2
6C hex	Current min.	Measurement value of current min.	Read	UINT	* 2
6D hex	Current max.	Measurement value of current max.	Read	UINT	* 2
6E hex	Degradation level 1 status	Displays the monitoring condition of degradation level 1. For details, refer to "Measurement status (common form of measurement value)". *1	Read	UINT	Depends on the condition.
6F hex	Degradation level 1 pv	Measurement value of degradation level 1 pv	Read	UINT	* 2
70 hex	Degradation level 1 min.	Measurement value of degradation level 1 min.	Read	UINT	* 2
71 hex	Degradation level 1 max.	Measurement value of degradation level 1 max.	Read	UINT	* 2
72 hex	Degradation level 2 status	Displays the monitoring condition of degradation level 2.	Read	UINT	Depends on the condition.
73 hex	Degradation level 2 pv	Measurement value of degradation level 2 pv	Read	UINT	* 2
74 hex	Degradation level 2 min.	Measurement value of degradation level 2 min.	Read	UINT	* 2
75 hex	Degradation level 2 max.	Measurement value of degradation level 2 max.	Read	UINT	* 2
76 hex	Reserved area	Reserved area	Read	UINT	0000 hex
77 hex	Reserved area	Reserved area	Read	UINT	0000 hex
78 hex	Reserved area	Reserved area	Read	UINT	0000 hex
79 hex	Reserved area	Reserved area	Read	UINT	0000 hex

*1. Measurement status (common form of measurement value)

Bit position	Status	Bit content	
		0	1
0	Present value unmeasured state	Measured	Standby
1	Present value input error	Not occurred	Occurrence
2	Reserved area		
3	Reserved area		
4	Maximum value unmeasured state	Measured	Standby
5	Maximum value input error	Not occurred	Occurrence
6	Reserved area		
7	Reserved area		
8	Minimum value unmeasured state	Measured	Standby
9	Minimum value input error	Not occurred	Occurrence
10	Reserved area		
11	Reserved area		
12	Individual alarm result (Warning)	OFF	ON
13	Individual alarm result (Critical)	OFF	ON
14	Reserved area		
15	Reserved area		

*2. Depends on measurement value.



Precautions for Correct Use

If the trigger mode is "Free run (no trigger)", read the data when "Present value not measured" bit (bit 00) of the measurement status is 0.

There is a possibility that the value before monitoring (i.e., 0) is being read.

● Vibration & temperature type (K6CM-VBM)

Attribute ID	Parameter name	Description	Attribute	Data	
				Data type	Default value
6A hex	Acceleration status	Displays the measurement status. For details, refer to "Measurement status (common form of measurement value)". *1	Read	UINT	Depends on the condition.
6B hex	Acceleration pv	Measurement value of acceleration pv	Read	UINT	* 2
6C hex	Acceleration min.	Measurement value of acceleration min.	Read	UINT	* 2
6D hex	Acceleration max.	Measurement value of acceleration max.	Read	UINT	* 2
6E hex	Velocity status	Displays the measurement status. For details, refer to "Measurement status (common form of measurement value)". *1	Read	UINT	Depends on the condition.
6F hex	Velocity pv	Measurement value of velocity pv	Read	UINT	* 2
70 hex	Velocity min.	Measurement value of velocity min.	Read	UINT	* 2
71 hex	Velocity max.	Measurement value of velocity max.	Read	UINT	* 2
72 hex	Motor temperature status	Displays the measurement status. For details, refer to "Measurement status (common form of measurement value)". *1	Read	UINT	Depends on the condition.
73 hex	Motor temperature pv	Measurement value of motor temperature pv	Read	UINT	* 2
74 hex	Motor temperature min.	Measurement value of motor temperature min.	Read	UINT	* 2
75 hex	Motor temperature max.	Measurement value of motor temperature max.	Read	UINT	* 2
76 hex	Temperature gap status	Displays the measurement status. For details, refer to "Measurement status (common form of measurement value)". *1	Read	UINT	Depends on the condition.
77 hex	Temperature gap pv	Measurement value of temperature gap pv	Read	UINT	* 2
78 hex	Temperature gap min.	Measurement value of temperature gap min.	Read	UINT	* 2
79 hex	Temperature gap max.	Measurement value of temperature gap max.	Read	UINT	* 2

*1. Measurement status (common form of measurement value)

Bit position	Status	Bit content	
		0	1
0	Present value unmeasured state	Measured	Standby
1	Present value input error	Not occurred	Occurrence
2	Reserved area		
3	Reserved area		
4	Maximum value unmeasured state	Measured	Standby
5	Maximum value input error	Not occurred	Occurrence
6	Reserved area		
7	Reserved area		
8	Minimum value unmeasured state	Measured	Standby
9	Minimum value input error	Not occurred	Occurrence
10	Reserved area		
11	Reserved area		
12	Individual alarm result (Warning)	OFF	ON
13	Individual alarm result (Critical)	OFF	ON
14	Reserved area		
15	Reserved area		

*2. Depends on measurement value.

● Insulation resistance type (K6CM-ISM)

Attribute ID	Parameter name	Description	Attribute	Data	
				Data type	Default value
6A hex	Insulation resistance status	Displays the measurement status. For details, refer to "Measurement status (common form of measurement value)". *1	Read	UINT	Depends on the condition.
6B hex	Insulation resistance pv	Measurement value of insulation resistance pv	Read	UINT	* 2
6C hex	Insulation resistance min.	Measurement value of insulation resistance min.	Read	UINT	* 2
6D hex	Insulation resistance max.	Measurement value of insulation resistance max.	Read	UINT	* 2
6E hex	I0r status	Displays the measurement status. For details, refer to "Measurement status (common form of measurement value)". *1	Read	UINT	Depends on the condition.
6F hex	I0r pv	Measurement value of I0r pv	Read	UINT	* 2
70 hex	I0r min.	Measurement value of I0r min.	Read	UINT	* 2
71 hex	I0r max.	Measurement value of I0r max.	Read	UINT	* 2
72 hex	I0c status	Displays the measurement status. For details, refer to "Measurement status (common form of measurement value)". *1	Read	UINT	Depends on the condition.
73 hex	I0c pv	Measurement value of I0c pv	Read	UINT	* 2
74 hex	Reserved area	Reserved area	Read	UINT	0000 hex
75 hex	Reserved area	Reserved area	Read	UINT	0000 hex
76 hex	Reserved area	Reserved area	Read	UINT	0000 hex
77 hex	Reserved area	Reserved area	Read	UINT	0000 hex
78 hex	Reserved area	Reserved area	Read	UINT	0000 hex
79 hex	Reserved area	Reserved area	Read	UINT	0000 hex

*1. Measurement status (common form of measurement value)

Bit position	Status	Bit content	
		0	1
0	Present value unmeasured state	Measured	Standby
1	Present value input error	Not occurred	Occurrence
2	Reserved area		
3	Reserved area		
4	Maximum value unmeasured state	Measured	Standby
5	Maximum value input error	Not occurred	Occurrence
6	Reserved area		
7	Reserved area		
8	Minimum value unmeasured state	Measured	Standby
9	Minimum value input error	Not occurred	Occurrence
10	Reserved area		
11	Reserved area		
12	Individual alarm result (Warning)	OFF	ON
13	Individual alarm result (Critical)	OFF	ON
14	Reserved area		
15	Reserved area		

*2. Depends on measurement value.

8-3-4 Setting Object (Class ID: 371 hex)

This object sets up the K6CM device itself and sets up measurement and alarm.

Service Code

Service code	Service name	Description	Supported services	
			Classes	Instances
02 hex	Set_Attributes_All	Write values to all attributes.* ¹	Not supported.	Supported.
10 hex	Set_Attribute_Single	Write the value of the specified attribute.	Not supported.	Supported.
01 hex	Get_Attributes_All	Reads the values of all attributes.	Not supported.	Supported.* ²
0E hex	Get_Attribute_Single	Reads the value of the specified attribute.	Not supported.	Supported.

*1. The attributes to be written are attribute IDs 64 to 78 hex. Be sure to set "0" to the attribute IDs: 64 hex and 65 hex. When you perform various resets, set with Set_Attribute_Single. Set the functions implemented by the version upgrade of attribute ID A0 hex or later by Set_Attribute_Single.

*2. Attribute IDs 64 to 78 hex are read.

Functions implemented by upgrading such as A0 hex of attribute ID can not be read by Get_Attributes_All, but can be read by Get_Attribute_Single.

The data size is 42 bytes for Get_Attributes_All.

Class ID

Specify 371 hex.

Instance ID

Specify 01 hex.

Attribute ID

● Common to K6CM

Attribute ID	Parameter name	Description	Attribute	Data	
				Data type	Default value
64 hex	Software reset	Restarts the K6CM device. It is used to validate the setting after changing the setting value.* ¹ Rising from 0 to 1: Execute (software reset)	Write	UINT	0000 hex
65 hex	Max./min. reset	Initializes the Max./min. value. OFF to ON: Execute (initialize max. and min. value)	Write	UINT	0000 hex
66 hex	Display value type	Sets which measurement value is displayed in the 7 segment display on the front of the K6CM device. 0: PV (Present value) 1: MIN 2: MAX	Write	UINT	0000 hex

Attribute ID	Parameter name	Description	Attribute	Data	
				Data type	Default value
67 hex	Trigger mode	Selects the trigger mode. 0: Free run 1: External trigger 2: Internal trigger	Write	UINT	0000 hex
68 hex	Trigger type	Set the trigger measurement start condition. Setting is not required when the trigger mode is "Free run". 0: Rising edge 1: Falling edge 2: Level	Write	UINT	0000 hex
69 hex	Trigger level	For "Internal trigger", set the measurement value to start trigger measurement. Setting is not required when the trigger mode is "Free run" or "External trigger". Note : Unit and decimal point position follow measurement values. (Refer to A-6 Internal Data of K6CM Devices on page A-14.)	Write	UINT	0000 hex
6A hex	Monitoring time	Sets the monitoring time. 1 to 6000 (unit: 0.1 seconds) (0001 to 1770 hex)	Write	UINT	0001 hex (1) (Unit: 0.1 seconds)
6B hex	Alarm latch	Sets enable/disable of alarm latch function. 0: Disable (no latch) 1: Enable (with latch)	Write	UINT	0001 hex
6C hex	Use Running Time	Sets the usage or nonuse of K6CM remaining capacity function. 0: OFF (not used) 1: ON (use)	Write	UINT	0000 hex
6D hex	Moving average times	Every time the measurement value is sampled, the data of the past n times including the sampling data of that time is averaged.*2 0: OFF 1: 2 times 2: 4 times 3: 8 times 4: 16 times 5: 32 times	Write	UINT	Comprehensive current diagnosis type: 0003 hex Vibration & temperature type, Insulation resistance type: 0000 hex
A0 hex	Transistor output method*3	Select transistor output method. 0: Normally Close 1: Normally Open	Write	UINT	0000 hex
A1 hex	Monitoring delay time*4	Set the delay time from the trigger input to the start of measurement. 0.0 to 6000 (unit: 0.1 seconds) (0000 to 1770 hex)	Write	UINT	0000 hex

*1. If you execute the software reset after writing to the attribute ID 65 to 78 hex or A0 to A4 hex, wait for about 1 second, considering the time until these setting values are saved, and then execute the software reset.

*2. If this attribute is set when using K6CM-CI2M, the value is set for both attribute ID A2 hex (current moving average times) and attribute ID A3 hex (degradation level 1 moving average times) at the same time.

*3. Transistor output method is a function implemented by version upgrade.

Eip cpu version: Implemented in the K6CM device with version 1.10 or higher. The Eip cpu version can be confirmed by the following method.

- Confirm the description of the side label of the K6CM device
- Confirmation the read data using the software tool or message communications

*4. The monitoring delay time is a function implemented by version upgrade.

Eip cpu version: Implemented in the K6CM device with version 1.20 or higher. The Eip cpu version can be confirmed by the method described in *3.

● Comprehensive current diagnosis type (K6CM-CI2M)

Attribute ID	Parameter name	Description	Attribute	Data	
				Data type	Default value
6E hex	Current range	Sets the current range. 0: 5 A 1: 25 A 2: 100 A 3: 200 A 4: 400 A 5: 600 A	Write	UINT	0003 hex
6F hex	Reserved area	Reserved area	Write	UINT	0000 hex
70 hex	Reserved area	Reserved area	Write	UINT	0000 hex
71 hex	Current failure warning	Sets the current failure warning threshold. 0 to 9999 (Unit in the 5 A range: 0.01 A) (Unit in other ranges: 0.1 A) (0000 to 270F hex)	Write	UINT	07D0 hex (2000)
72 hex	Current failure critical	Sets the current failure critical threshold. 0 to 9999 (Unit in the 5 A range: 0.01 A) (Unit in other ranges: 0.1 A) (0000 to 270F hex)	Write	UINT	07D0 hex (2000)
73 hex	Degradation level 1 failure warning	Sets the degradation level 1 failure warning threshold. 0 to 9999 (0000 to 270F hex)	Write	UINT	001E hex (30)
74 hex	Degradation level 1 failure critical	Sets the degradation level 1 failure critical threshold. 0 to 9999 (0000 to 270F hex)	Write	UINT	0032 hex (50)
75 hex	Degradation level 2 failure warning	Sets the degradation level 2 failure warning threshold. 0 to 9999 (0000 to 270F hex)	Write	UINT	0014 hex (20)
76 hex	Degradation level 2 failure critical	Sets the degradation level 2 failure critical threshold. 0 to 9999 (0000 to 270F hex)	Write	UINT	0032 hex (50)
77 hex	Reserved area	Reserved area	Write	UINT	0000 hex

Attribute ID	Parameter name	Description	Attribute	Data	
				Data type	Default value
78 hex	Reserved area	Reserved area	Write	UINT	0000 hex
A2 hex	Current moving average times	Sets the current moving average times. 0: OFF 1: 2 times 2: 4 times 3: 8 times 4: 16 times 5: 32 times	Write	UINT	0000 hex
A3 hex	Degradation level 1 moving average times	Sets the degradation level 1 moving average times. 0: OFF 1: 2 times 2: 4 times 3: 8 times 4: 16 times 5: 32 times	Write	UINT	0003 hex
A4 hex	Degradation level 2 moving average times	Sets the degradation level 2 moving average times. 0: OFF 1: 2 times 2: 4 times 3: 8 times 4: 16 times 5: 32 times	Write	UINT	0000 hex

● Vibration & temperature type (K6CM-VBM)

Attribute ID	Parameter name	Description	Attribute	Data	
				Data type	Default value
6E hex	Temperature unit	Sets the temperature unit. 0: °C 1: °F	Write	UINT	0000 hex
6F hex	Reserved area	Reserved area	Write	UINT	0000 hex
70 hex	Reserved area	Reserved area	Write	UINT	0000 hex
71 hex	Acceleration failure warning	Sets the acceleration failure warning threshold. 0 to 9999 (Unit: 0.01 G) (0000 to 270F hex)	Write	UINT	0032 hex (50)
72 hex	Acceleration failure critical	Sets the acceleration failure critical threshold. 0 to 9999 (Unit: 0.01 G) (0000 to 270F hex)	Write	UINT	0064 hex (100)
73 hex	Velocity failure warning	Sets the velocity failure warning threshold. 0 to 9999 (Unit: 0.01 mm/s) (0000 to 270F hex)	Write	UINT	0FA0 hex (4000)
74 hex	Velocity failure critical	Sets the velocity failure critical threshold. 0 to 9999 (Unit: 0.01 mm/s) (0000 to 270F hex)	Write	UINT	1194 hex (4500)
75 hex	Motor temperature failure warning	Sets the motor temperature failure warning threshold. 0 to 9999 (Unit: °C) (0000 to 270F hex)	Write	UINT	0050 hex (80)
76 hex	Motor temperature failure critical	Sets the motor temperature failure critical threshold. 0 to 9999 (Unit: °C) (0000 to 270F hex)	Write	UINT	0050 hex (80)
77 hex	Temperature gap failure warning	Sets the temperature gap failure warning threshold. 0 to 9999 (Unit: °C) (0000 to 270F hex)	Write	UINT	0050 hex (80)
78 hex	Temperature gap failure critical	Sets the temperature gap failure critical threshold. 0 to 9999 (Unit: °C) (0000 to 270F hex)	Write	UINT	0050 hex (80)

● Insulation resistance type (K6CM-ISM)

Attribute ID	Parameter name	Description	Attribute	Data	
				Data type	Default value
6E hex	Circuit topology	Sets the applied circuit. 0: Three-phase three-wire system, S-phase grounding 1: Three-phase four-wire system, N-phase grounding, delta connection load	Write	UINT	0000 hex
6F hex	Using inverter	Sets the presence or absence of the inverter. 0: OFF (No inverter) 1: ON (with inverter)	Write	UINT	0000 hex
70 hex	Inverter special measurement	Sets the inverter special measurement. 0: OFF 1: ON Special calculation to do when inverter frequency and commercial frequency are close. Note : Using inverter = "with inverter" only valid For how to use this function, refer to the <i>Wiring Diagram of the Insulation Resistance Type (K6CM-IS)</i> on page 5-27 in <i>5-6 I/O wiring</i> on page 5-25.	Write	UINT	0000 hex
71 hex	Insulation resistance failure warning	Sets the Insulation resistance failure warning threshold. 0 to 9999 (unit: 0.001 MΩ) (0000 to 270F hex)	Write	UINT	0320 hex (800)
72 hex	Insulation resistance failure critical	Sets the Insulation resistance failure critical threshold. 0 to 9999 (unit: 0.001 MΩ) (0000 to 270F hex)	Write	UINT	0190 hex (400)
73 hex	Reserved area	Reserved area	Write	UINT	0000 hex
74 hex	Reserved area	Reserved area	Write	UINT	0000 hex
75 hex	Reserved area	Reserved area	Write	UINT	0000 hex
76 hex	Reserved area	Reserved area	Write	UINT	0000 hex
77 hex	Reserved area	Reserved area	Write	UINT	0000 hex
78 hex	Reserved area	Reserved area	Write	UINT	0000 hex

8-3-5 Identity Object (Class ID: 01 hex)

This object reads the identification information of the K6CM, reads the state of the built-in EtherNet/IP port, and resets the K6CM.

Service Codes

Service code	Service name	Description	Supported services	
			Classes	Instances
01 hex	Get_Attributes_All	Reads the values of all attributes. *1	Supported*1.	Supported.
0E hex	Get_Attribute_Single	Reads the value of the specified attribute.	Supported.	Supported.
05 hex	Reset	Resets the K6CM. This parameter is used to reset the K6CM when you change the parameter settings and want to apply them.	Not supported.	Supported.

*1. The following data is obtained by Get_Attributes_All.

Parameter name	Data	
	Data type	Value
Revision	UINT	0001 hex
Reserved area	UINT	0001 hex
Reserved area	UINT	0000 hex
Reserved area	UINT	0000 hex

For Get_Attributes_All, the data size is 8 bytes for the class and 28 bytes for the instance.

Class ID

Specify 01 hex.

Instance ID

Specify the following data according to the target.

Class: 00 hex

Instance: 01 hex

Attribute ID

The attribute ID specifies the information to read.

● Class Attribute ID

The class attribute ID specifies the attribute of the object class.

Attribute ID	Parameter name	Description	Attribute	Data	
				Data type	Default value
01 hex	Revision	Revision of the object	Read	UINT	0001 hex

● Instance Attribute ID

The instance attribute ID specifies the per-instance attribute.

Attribute ID	Parameter name	Description	Attribute	Data	
				Data type	Default value
01 hex	Vendor ID	Vendor ID	Read	UINT	002F hex (Fixed value)
02 hex	Device Type	Device type	Read	UINT	0303 hex (Fixed value)
03 hex	Product Code	Product code	Read	UINT	For details, refer to "Product Codes". *1
04 hex	Revision	Device revision Example: For Revision 1.01	Read	Struct of	- - -
	Major Revision	Major Revision = 1	Read	USINT	Product specific
	Minor Revision	Minor revision = 1	Read	USINT	Product specific
05 hex	Status	Status of the built-in EtherNet/IP port For details, refer to "Status of the EtherNet/IP Port". *2	Read	WORD	- - -
06 hex	Serial Number	Serial number	Read	UDINT	Product specific (Serial number)
07 hex	Product Name	Product name	Read	SHORT_STRING	Product specific For details, refer to "Product Codes". *1

*1. Product Codes

Model name	Product Code	Product name (number of characters (1 byte) + character string)
K6CM-VBMx-EIP	1FC hex (508)	0D 4B 36 43 4D 2D 56 42 4D 78 2D 45 49 50
K6CM-ISMx-EIP	1FD hex (509)	0D 4B 36 43 4D 2D 49 53 4D 78 2D 45 49 50
K6CM-CI2Mx-EIP	1FF hex (511)	0E 4B 36 43 4D 2D 43 49 32 4D 78 2D 45 49 50

The number of characters (0D hex) is added to the beginning of K6CM-VBM and K6CM-ISM.

The number of characters (0E hex) is added to the beginning of K6CM-CI2M.

*2. Status of the EtherNet/IP Port

Bit	Name	Description
0	Owned	Indicates when the built-in EtherNet/IP port has an open connection as the target of a tag data link.
1	Reserved area	Always FALSE.
2	Configured	Tag data link settings exist. 0: Disable (no latch) 1: Enable (with latch)
3	Reserved area	Always FALSE.
4 to 7	Extended Device Status Vendor specific setting area	Indicates the status of the built-in EtherNet/IP port. 0: Not used 1: Not used 2: One or more I/O connection failures 3: I/O connection is not established 4: Not used 5: Serious defect occurred (MS Criticality) 6: One or more I/O connections are established and one or more are in the RUN state 7: One or more I/O connections are established and all are idle 8 to 15: Unused
8	Minor Recoverable Fault Vendor specific setting area	Always FALSE.
9	Minor Unrecoverable Fault Vendor specific setting area	Always FALSE.

Bit	Name	Description
10	Major Recoverable Fault Vendor specific setting area	When the MS indicator matches conditions of the flashing red: True
11	Major Unrecoverable Fault Vendor specific setting area	When the MS indicator matches conditions of the flashing red: True
12 to 15	Reserved area	Always FALSE.

8-3-6 TCP/IP Interface Object (Class ID: F5 hex)

This object is used to read and write settings such as the IP address, subnet mask, and default gateway.

Service Codes

Service code	Service name	Description	Supported services	
			Classes	Instances
01 hex	Get_Attributes_All	Reads the values of all attributes.	Not supported.	Supported.
0E hex	Get_Attribute_Single	Reads the value of the specified attribute.	Supported.	Supported.
10 hex	Set_Attribute_Single	Writes the value to the specified attribute.	Not supported.	Supported.

The data size is 96 bytes (by default) for Get_Attributes_All.

Class ID

Specify F5 hex.

Instance ID

Specify 01 hex.

Attribute ID

The attribute ID specifies the information to read.

● Class Attribute ID

The class attribute ID specifies the attribute of the object class.

Attribute ID	Parameter name	Description	Attribute	Data	
				Data type	Default value
01 hex	Revision	Revision of the object	Read	UINT	0004 hex

● Instance Attribute ID

The instance attribute ID specifies the per-instance attribute.

Attribute ID	Parameter name	Description	Attribute	Data	
				Data type	Default value
01 hex	Interface Configuration Status	Indicates the IP address settings status of the interface.	Read	DWORD	Bits 0 to 3: Interface Configuration Status: 0 = IP address is not set. (This includes when BOOTP is starting.) 1 = IP address is set. Bit 5: A state in which the IP address setting is changed in Interface Configuration Pending: 1 = State in which the IP address setting has been changed and the setting change is not reflected yet (waiting for Reset) Bits 4, Bits 6 to 31: Reserved area (always FALSE).
02 hex	Configuration Capability	Indicates a Setup that can be set to the built-in interface.	Read	DWORD	Bit 0: BOOTP Client: Always TRUE. Bit 1: DNS Client: Always FALSE. Bit 2: DHCP Client: Always FALSE. Bit 3: DHCP-DNS Update: Always FALSE. Bit 4: Configuration Settable: Always TRUE. Bit 5: Hardware Configurable: Always FALSE. Bit 6: Interface Configuration Change Requires Reset: Always TRUE. Bit 7: ACD Capable: Always FALSE. Bits 8 to 31: Reserved area (always FALSE).
03 hex	Configuration Control	Sets the method used to set the IP address when the interface starts.	Write	DWORD	00000000 hex: Static IP address. 00000001 hex: Set by BOOTP.
04 hex	Physical Link Object	The path to the link object in the physical layer	Read	Struct of	-
	Path size	The path size (WORD size).		UINT	0002 hex (Fixed)
	Path	The path to the link object in the physical layer (static).		Padded EPATH	20F6 2401 hex (Fixed)
05 hex	Interface Configuration	The built-in EtherNet/IP port settings.	Write	Struct of	-
	IP Address	IP address.		UDINT	192.168.250.10 (C0A8FA0A hex)
	Network Mask	Subnet mask.		UDINT	255.255.255.0 (FFFFFF00 hex)
	Gateway Address	The default gateway.		UDINT	0.0.0.0 (00000000 hex)
	Name Server	The primary name server.		UDINT	0.0.0.0 (00000000 hex)
	Name Server2	The secondary name server.		UDINT	0.0.0.0 (00000000 hex)
	Domain Name	The domain name.		STRING	0.0.0.0 (00000000 hex)
06 hex	Host Name	The host name (reserved).	Write	STRING	Always 0000 hex.
07 hex	Reserved area		*1	(6 bytes)	Always 0 hex.
08 hex	Reserved area		*1	(1 byte)	Always 1 hex.
09 hex	Reserved area		*1	(8 bytes)	Always 0 hex.
0A hex	Reserved area		*1	(1 byte)	Always 0 hex.
0B hex	Reserved area		*1	(35 bytes)	Always 0 hex.
0C hex	Reserved area		*1	(1 byte)	Always 0 hex.
0D hex	Encapsulation Inactivity Timeout	Encapsulation session timeout time	Write	UINT	0001 to 0E10 hex: 1 to 3600 s (0: prohibited) Default: 0078 hex (120 s)

*1. It is unsupported. Therefore the fixed value is read only when reading with Get_Attributes_All.

8-3-7 Examples of CIP Message Communications Instruction

The following is an example of reading the measurement value of the K6CM using the CIP message communications instruction of the NJ/NX-series Controller.

The CIPUCMMSend (Send Explicit Message UCMM) instruction is used a CIP message communications instruction.

Send the following CIP message.

- Service code: 16#0E (Get_Attribute_Single: read the value of the specified attribute)
- Class ID: 370 hex
- Instance ID: 01 hex
- Attribute ID: 6F hex (degradation level 1 pv)

The CIPUCMMSend instruction sends the command data "ServiceDat" as a UCMM message corresponding to the service specified by the "ServiceCode".

The destination is specified by the route path "RoutePath". The request path is specified by "RqPath".

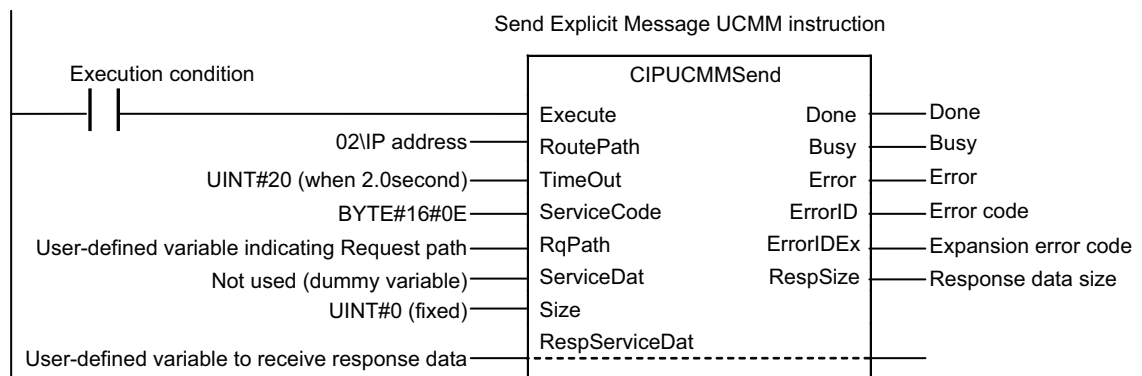

Set the following value to the input variable of the above communications instruction.

Input variable of the communications instruction	Specification	Value to pass to input variable	Meaning
RoutePath	Route path specification	02\IPaddress	"02" specifies the output from the NJ-series built-in EtherNet/IP port or the NX-series ibuilt-in EtherNet/IP port 1. The IP address specifies the IP address of Comprehensive current diagnosis type (K6CM-CI2M).
TimeOut	Timeout time specification	UINT#20	Timeout time is specified. The integer "20" specifies 2.0 s as the timeout time. It is 0.1s unit.
ServiceCode	Service code	BYTE#16#0E	0EHex specifies "Service_Attribute_Single" as a service code which reads the value of the specified attribute.

Input variable of the communications instruction	Specification	Value to pass to input variable	Meaning
RqPath	Request path specification	Specified by user variable indicating the Request path	Specify a user-defined variable. Use the data type "_sREQUEST_PATH" corresponding to the input variable "RqPath". You can use any variable name. Specify the following. Class ID, Instance ID, Attribute ID Example) Degradation level 1 pv: Specify the following. <ul style="list-style-type: none"> • ClassID: = 370 hex (meaning "K6CM monitor object") • InstanceID: = 01 hex (fixed) • IsAttributeID: = TRUE (meaning to use an attribute ID) AttributeID: = 6 FHex (meaning degradation level 1 pv)
ServiceDat	Data to send	Not used (dummy variable)	Since the service code is "read", specify a Dummy variable (any data type).
Size	Number of elements to send	UINT#0	Since the service code is "read", specify integer 0 (fixed).
RespService-Dat	Response data specification	Specified by user variable r variable to receive response data	Specify a user-defined variable. Use the data type "ARRAY [0..10] OF BYTE" corresponding to the input/output variable "RespServiceDat". You can use any variable name.

8-4 Sample Program for the NJ/NX-series

This section describes the motor monitoring procedure using K6CM devices and NJ/NX-series.Controller.

8-4-1 Sample Program Overview

The following processing can be executed using the sample program described here.

- Obtains measurement data of up to 100 K6CM devices with one PLC (NJ/NX series)
- Outputs the obtained measurement data as a CSV file to the SD Memory Card mounted on the PLC

The output CSV file name is determined from the date of data obtainment according to the internal clock of the PLC.

(Example: file name: K6CM_20171208-1520.CSV in the case of 15:20 on December 8, 2017)

The following are the parameters that can be set in this sample program, what to prepare, the network configuration example, and the output CSV file specifications.

Parameters that can be set in this sample program

Parameters	Initial value	Remarks
Number of data collection devices [Units]	20	Set according to the number of K6CM devices to be used. Up to 100 Units can be set.
Communications retry count [times]	1	Change as necessary. Setting the number of retries is effective for communications failure due to irregular external noise. However, since wait time occurs correspondingly, the setting of the data collection cycle shown below will be affected.
Data collection cycle [sec]	30	If there is a K6CM device that does not respond to the communications, the following wait time will occur at maximum. Therefore, it is necessary to set it to a value larger than the expected maximum waiting time. Maximum waiting time [sec] = (CIP timeout time × 4) × (1 + communications retry count) × number of cycles + CSV output time CIP timeout time: 1 s (initial value) CSV output time: about 3 s Number of cycles: An integer obtained by dividing the number of data collection devices by the number of parallel connection (initial value: 10) (The decimal point is rounded up.) Example: calculation with initial value Maximum waiting time = (1 × 4) × (1 + 1) × (20 ÷ 10) + 4 = 20 s -> The data collection cycle requires 20 s or more with a margin

What to Prepar and Network Configuration Example

● What to Prepare

- K6CM devices (Any model, up to 100 Units in total can be connected.)
- Switching hub (SW hub)
- STP cable (for Ethernet communications)

● **K6CM Device Collected Data**

• K6CM-CI2Mx

Common to K6CM all models			Specific to the K6CM type												
IP address	Running Time	Number of Triggers	Current status	Current pv	Current min.	Current max.	Degradation level 1 status	Degradation level 1 pv	Degradation level 1 min.	Degradation level 1 max.	Degradation level 2 status	Degradation level 2 pv	Degradation level 2 min.	Degradation level 2 max.	->

Specific to the K6CM type						
->	Current failure warning	Current failure critical	Degradation level 1 failure warning	Degradation level 1 failure critical	Degradation level 2 failure warning	Degradation level 2 failure critical

• K6CM-VBMx

Common to K6CM all models			Specific to the K6CM type												
IP address	Running Time	Number of Triggers	Acceleration status	Acceleration pv	Acceleration min.	Acceleration max.	Velocity status	Velocity pv	Velocity min.	Velocity max.	Motor temperature status	Motor temperature pv	Motor temperature min.	Motor temperature max.	->

Specific to the K6CM type													
->	Temperature gap status	Temperature gap pv	Temperature gap min.	Temperature gap max.	Acceleration failure warning	Acceleration failure critical	Velocity failure warning	Velocity failure critical	Motor temperature failure warning	Motor temperature failure critical	Temperature gap failure warning	Temperature gap failure critical	Temperature gap failure critical

• K6CM-ISMx

Common to K6CM all models			Specific to the K6CM type											
IP address	Running Time	Number of Triggers	Insulation resistance status	Insulation resistance pv	Insulation resistance min.	Insulation resistance max.	I0r status	I0r pv	I0r min.	I0r max.	I0c status	I0c pv	Insulation resistance failure warning	Insulation resistance failure critical

8-4-2 Sample Program Processing Flow and Function Block Specifications

This section describes the processing flow of the sample program and the specification of the function block.

Sample Program Processing Flow

Set the following initial information in the first cycle after start up.

- Connection destination IP address
- Number of connected devices
- Number of parallel connection
- number of retries
- Data collection cycle

Initialize the effective device status (bEnable) according to the number of connected devices.

Initialize the data collection target device (iSelectableUNIT).

The operation after the initial setting is as shown in the flow chart.

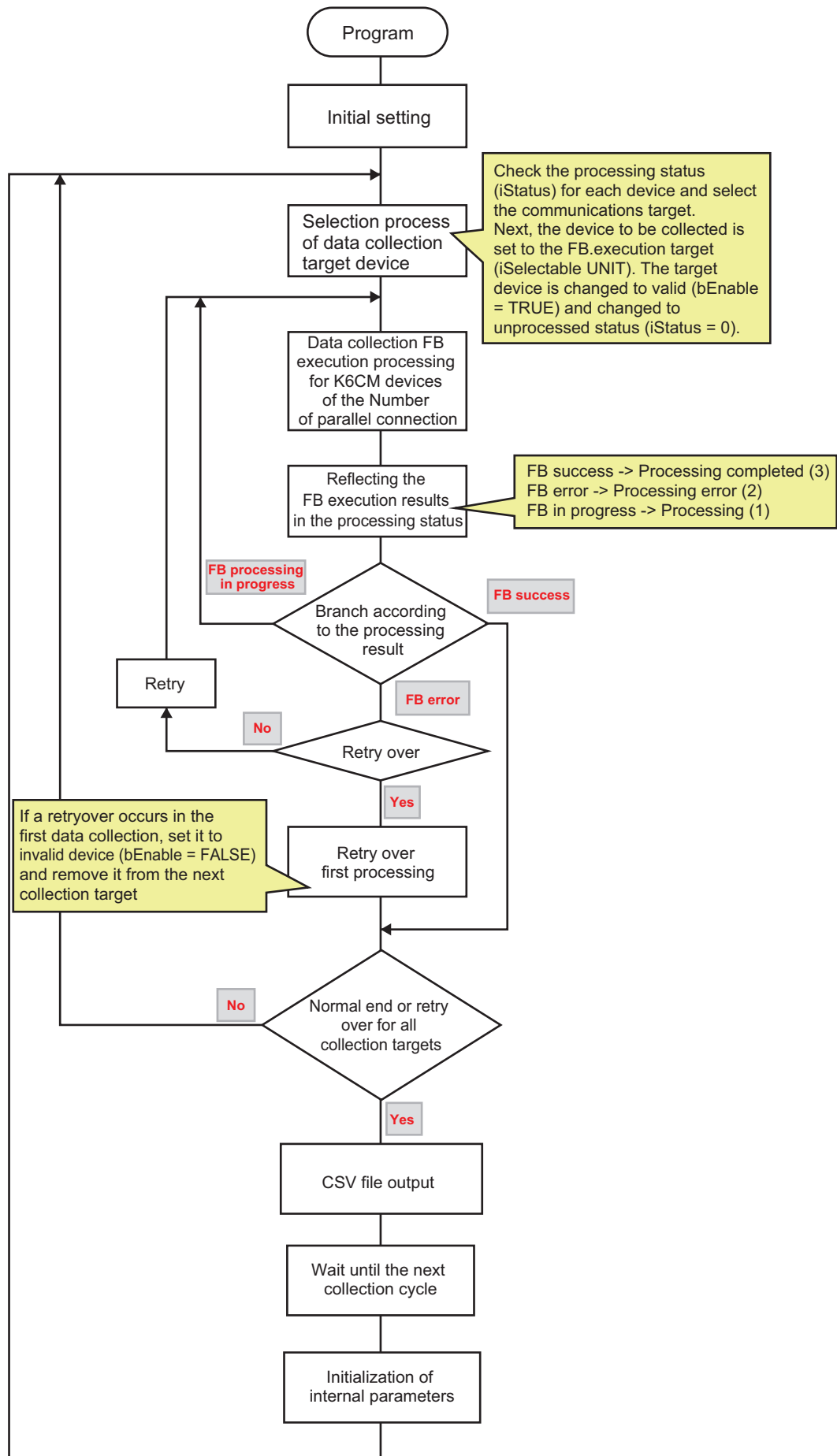

The variables defined in the sample program are as follows.

(These are the main variables except instance related and work related variables etc. Refer to the actual sample program for details.)

Variable name	Variable data type	Description
sIPAddress	ARRAY[0..99] OF STRING[256]	Connection destination IP Addresses 100 settings
iNumOfUnits	UINT	Number of connected devices (setting)
iNumOfParallel	UINT	Number of parallel connection (setting)
iRetryValue	UINT	Number of retries setting
tOutputCycle	TIME	Data output cycle (setting)
bCollecting	BOOL	During the collection of K6CM devices data
bOutput	BOOL	During output to the CSV file
iSelectableUNIT	ARRAY[0..9] OF UINT	FB execution target device No.
bExecute	ARRAY[0..9] OF BOOL	FB execution command
bDone	ARRAY[0..9] OF BOOL	FB completion state
bBusy	ARRAY[0..9] OF BOOL	FB processing in progress
bError	ARRAY[0..9] OF BOOL	FB error condition
wErrID	ARRAY[0..99] OF WORD	Device error code
bEnable	ARRAY[0..99] OF BOOL	Device enabled state (True: valid, False: invalid)
iStatus	ARRAY[0..99] OF UINT	Device processing state * 1
iRetryCnt	ARRAY[0..99] OF UINT	Device retry count
iProCode	ARRAY[0..99] OF UINT	Device type (1: VBM, 2: ISM, 3: CI2M)
stRespServiceDat	ARRAY[0..99] OF K6CM_ReadData	Device reception data

- *1. Device processing state
- 0 : Unprocessed
 - 1 : Processing (FB running)
 - 2 : Error (FB error occurred)
 - 3 : Collection completed (FB successful completion)
 - 4 : Retry over (missing measurement)

Function Block Specifications

This FB reads data from the K6CM device whose IP address is specified in the input data, using the CIPUCMMSend command by rising of the Execute.

* Do not restart the FB by the Execute while FB is executing. Communications processing is initialized.

Instruction	Name	Graphic expression	ST expression
K6CM_Read	Read K6CM Devices Data		<pre>K6CM_Read_instance(Execute, IPAddress, TimeOut, Done, Busy, Error, ErrorID, ErrorIDEx, ProductCode, RespServiceDat);</pre>

Variable name:	Input/output	Data type	Description
Execute	IN	BOOL	Execution

Variable name:	Input/output	Data type	Description
IPAddress	IN	STRING[256]	Connection destination IP Address
TimeOut	IN	UINT	CIP command timeout (x0.1 second)
Done	OUT	BOOL	Successful completion
Busy	OUT	BOOL	Executing
Error	OUT	BOOL	Error end
ErrorID	OUT	WORD	Error code *1
ErrorIDEx	OUT	DWORD	Expansion error code *2
ProductCode	OUT	UINT	Product code *3
RespServiceDat	OUT	K6CM_ReadData	Response data

*1. The response code of the CIP command request (CIPUCMMSend instruction) is returned to the error code.

*2. When the value of "ErrorID" is WORD#16#1C00 (i.e., Explicit error), CIP message error code is stored in "ErrorIDEx". For details of "ErrorIDEx", refer to "A-10 Expansion Error Code of the CIP Message Communications on page A-48".

*3. Product code: The following values are returned according to the model

K6CM-CI2M: 3

K6CM-VBM: 1

K6CM-ISM: 2

Others: 0

Response data of the function block is a structure with the following members.

Name	Data type	Comment
K6CM_ReadData	STRUCT	
dtDataTime	DATE_AND_TIME	Data obtainment time
stIdentity	Identity	Identity Object
stMonCom	MonCom	Monitor object (Common)
stMonVBM	MonVBM	Monitor object (VBM)
stMonISM	MonISM	Monitor object (ISM)
stMonCIM	MonCIM	Monitor object (CIM)
stSetCom	SetCom	Setting object (Common)
stSetVBM	SetVBM	Setting object (VBM)
stSetISM	SetISM	Setting object (ISM)
stSetCIM	SetCIM	Setting object (CIM)
Identity	STRUCT	Identity Object
iVendorID	UINT	Vendor ID
iDeviceType	UINT	Device type
iProductCode	UINT	Product code
isMajorRevision	USINT	Major revision
isMinorRevision	USINT	Minor revision
wStatus	WORD	EtherNet/IP status
idSerialNo	UDINT	Serial number
sProductName	STRING[256]	Model name
MonCom	STRUCT	Monitor object (Common)
sMeasVer	STRING[256]	Mes cpu version
sMainVer	STRING[256]	Main cpu version
sEIPVer	STRING[256]	Eip cpu version
wStatus	WORD	Main body status
iRunningTime	UINT	Running Time
iTriggerCnt	UINT	Number of Triggers
MonVBM	STRUCT	Monitor object (VBM)
wAccStatus	WORD	Acceleration status
rAccValue	REAL	Acceleration pv

Name	Data type	Comment
rAccMin	REAL	Acceleration min.
rAccMax	REAL	Acceleration max.
wVelStatus	WORD	Velocity status
rVelValue	REAL	Velocity pv
rVelMin	REAL	Velocity min.
rVelMax	REAL	Velocity max.
wMotorTempStatus	WORD	Motor temperature status
iMotorTempValue	UINT	Motor temperature pv
iMotorTempMin	UINT	Motor temperature min.
iMotorTempMax	UINT	Motor temperature max.
wDiffTempStatus	WORD	Temperature gap status
iDiffTempValue	UINT	Temperature gap pv
iDiffTempMin	UINT	Temperature gap min.
iDiffTempMax	UINT	Temperature gap max.
MonISM	STRUCT	Monitor object (ISM)
wInsRegistStatus	WORD	Insulation resistance status
rInsRegistValue	REAL	Insulation resistance pv
rInsRegistMin	REAL	Insulation resistance min.
rInsRegistMax	REAL	Insulation resistance max.
wIorStatus	WORD	I0r status
rIorValue	REAL	I0r pv
rIorMin	REAL	I0r min.
rIorMax	REAL	I0r max.
wIocStatus	WORD	I0c status
rIocValue	REAL	I0c pv
MonCIM	STRUCT	Monitor object (CIM)
wCurrentStatus	WORD	Current status
rCurrentValue	REAL	Current pv
rCurrentMin	REAL	Current min.
rCurrentMax	REAL	Current max.
wDegradation1Status	WORD	Degradation level 1 status
iDegradation1Value	UINT	Degradation level 1 pv
iDegradation1Min	UINT	Degradation level 1 min.
iDegradation1Max	UINT	Degradation level 1 max.
wDegradation2Status	WORD	Degradation level 2 status
iDegradation2Value	UINT	Degradation level 2 pv
iDegradation2Min	UINT	Degradation level 2 min.
iDegradation2Max	UINT	Degradation level 2 max.
SetCom	STRUCT	Setting object (Common)
iSoftReset	UINT	Software reset
iMaxMinReset	UINT	Max./min. reset
iDispValType	UINT	Display value type
iTriggerMode	UINT	Trigger mode
iTriggerType	UINT	Trigger type
iTriggerLevel	UINT	Trigger level
rMonitoringTime	REAL	Monitoring time
iAlarmLatch	UINT	Alarm latch
iUseRunningTime	UINT	Use Running Time
iMovingAveTimes	UINT	Moving average times
iTrOutputMethod	UINT	Transistor output method
rMonitoringDelayTime	REAL	Monitoring delay time

Name	Data type	Comment
SetVBM	STRUCT	Setting object (VBM)
iTempUnit	UINT	Temperature unit
rAccAlarm_Warning	REAL	Acceleration failure warning
rAccAlarm_Critical	REAL	Acceleration failure critical
rVelAlarm_Warning	REAL	Velocity failure warning
rVelAlarm_Critical	REAL	Velocity failure critical
iMotorTempAlarm_Warning	UINT	Motor temperature failure warning
iMotorTempAlarm_Critical	UINT	Motor temperature failure critical
iDiffTempAlarm_Warning	UINT	Temperature gap failure warning
iDiffTempAlarm_Critical	UINT	Temperature gap failure critical
SetISM	STRUCT	Setting object (ISM)
iApplicableCircuit	UINT	Circuit topology
iUsingInverter	UINT	Using inverter
iInverterSpecialMeas	UINT	Inverter special measurement
rInsRegistAlarm_Warning	REAL	Insulation resistance failure warning
rInsRegistAlarm_Critical	REAL	Insulation resistance failure critical
SetCIM	STRUCT	Setting object (CIM)
iCurrentRange	UINT	Current range
iCurrMovingAveTimes	UINT	Current moving average times
iDeg1MovingAveTimes	UINT	Degradation level 1 moving average times
iDeg2MovingAveTimes	UINT	Degradation level 2 moving average times
rCurrentAlarm_Warning	REAL	Current failure warning
rCurrentAlarm_Critical	REAL	Current failure critical
iDegradation1Alarm_Warning	UINT	Degradation level 1 failure warning
iDegradation1Alarm_Critical	UINT	Degradation level 1 failure critical
iDegradation2Alarm_Warning	UINT	Degradation level 2 failure warning
iDegradation2Alarm_Critical	UINT	Degradation level 2 failure critical
dummy	STRUCT	Dummy variable
sDummy	STRING[256]	Dummy variable
tTime	TIME	Dummy variable

8-4-3 Sample Program Execution Procedures

The following is the procedure to execute the sample program.

1 IP Address Settings of Devices

The setting method depends on the device. Set as follows:

K6CM: Set it with the start navigation of the software tool (Motor condition monitoring tool).

Refer to 4-3-2 *IP Address Setting of the K6CM Devices* on page 4-26

- PLC:
- If you have not imported the project file in the Sysmac Studio, set it with [Connect to Device] on the start page of the Sysmac Studio.
(Refer to the Sysmac Studio Version1 Operation Manual (Cat. No.W504) section 6-2-8)
 - If you have imported the project file in the Sysmac Studio, set it with [Communications Setup] of the Sysmac Studio.
(Refer to the Sysmac Studio Version1 Operation Manual (Cat. No.W504) section 6-2-2)

PC: Set it from the Control Panel. Refer to 4-2-2 *Uninstallation Procedures* on page 4-23.

2 Network configuration

Configure each device referring to the network configuration example described in 8-4-1 *Sample Program Overview* on page 8-30.

3 Importing the Sysmac Studio Project File

To import the sample program project file, perform one of the following:

- (1) Double-click the project file (.smc2, .csm2, etc.).

The Sysmac Studio starts and it is imported automatically.

- (2) Select [Import] in the start page of the Sysmac Studio and specify the project file.

After importing the file, perform the device settings according to the PLC model to be used as necessary.

Device settings can be performed from [Controller] | [Change Device] in the Sysmac Studio.

4 Setting of the PLC clock

Go online to the PLC, and then set the PLC clock with [Controller Clock] of the Sysmac Studio.
(Refer to the Sysmac Studio Version1 Operation Manual (Cat. No.W504) section 8-2)

5 Parameter Settings of the Sample Program

Set the following parameters as shown in the "Sample Program Code Descriptions".

Number of data collection devices: Number of K6CM devices to be used

Data collection cycle: cycle for collecting data from K6CM devices

Connection destination IP address: IP address of the K6CM device to be connected

6 Going Online to the PLC

Select [Online] from [Controller] in the Sysmac Studio.

(Confirm that the PC and PLC are connected in advance.)

7 Changing to PROGRAM mode

Select [PROGRAM Mode] from [Controller] | [Mode] in the Sysmac Studio.

Check the contents of the caution window and select [Yes].

- 8** Download the sample program to PLC
Select [Transfer to Controller] from [Controller] in the Sysmac Studio.
Select [Execute] in the content confirmation window.
Select [Yes] in the execution confirmation window.

- 9** Changing to RUN mode
Select [RUN Mode] from [Controller] | [Mode] in the Sysmac Studio.
Check the contents of the caution window and select [Yes].

With the above operation, the sample program will be executed and data collection will be started.

The measured data of the K6CM devices will be output as a CSV file to the SD Memory Card mounted to the PLC.

(Note: To prevent measured data corruption, change to Program mode before you remove the SD Memory Card.)

8-4-4 Sample Program Code Descriptions

This section shows the code descriptions of the sample program.

According to your system, set the parameter and the IP address that are described at the beginning of this program.

The subsequent codes are not required to edit unless there is special use.

● K6CM Sample Program Code Descriptions

```

1 // K6CM Sample Program
2
3 // Initialization
4 IF ( P_First_Run = TRUE ) THEN
5
6     INumOfUnits := UINT#20; // the number of data collection units (up to 100)
7     IRetryValue := UINT#1; // retry times for communications error
8     IOutputCycle := T#30s; // data collection cycle time (should be over 20 sec)
9
10    INumOfParallel := UINT#10; // the unit number of parallel connection (up to 10)
11    ICIPTimeOut := UINT#10; // CIP timeout (x 0.1 sec)
12
13    sIPAddress[UINT#0] := '192.168.250.101'; // connected IP address (up to 100 units)
14    sIPAddress[UINT#1] := '192.168.250.102'; // handled sequentially from top
15    sIPAddress[UINT#2] := '192.168.250.103'; // as only the amount set by INumOfUnits
16    sIPAddress[UINT#3] := '192.168.250.104';
17    sIPAddress[UINT#4] := '192.168.250.105';
18    sIPAddress[UINT#5] := '192.168.250.106';
19    sIPAddress[UINT#6] := '192.168.250.107';
20    sIPAddress[UINT#7] := '192.168.250.108';
21    sIPAddress[UINT#8] := '192.168.250.109';
22    sIPAddress[UINT#9] := '192.168.250.110';
23    sIPAddress[UINT#10] := '192.168.250.111';
24    sIPAddress[UINT#11] := '192.168.250.112';
25    sIPAddress[UINT#12] := '192.168.250.113';
26    sIPAddress[UINT#13] := '192.168.250.114';
27    sIPAddress[UINT#14] := '192.168.250.115';
28    sIPAddress[UINT#15] := '192.168.250.116';
29    sIPAddress[UINT#16] := '192.168.250.117';
30    sIPAddress[UINT#17] := '192.168.250.118';
31    sIPAddress[UINT#18] := '192.168.250.119';
32    sIPAddress[UINT#19] := '192.168.250.120';
33    sIPAddress[UINT#20] := '192.168.250.121';
34    sIPAddress[UINT#21] := '192.168.250.122';
35    sIPAddress[UINT#22] := '192.168.250.123';
36    sIPAddress[UINT#23] := '192.168.250.124';
37    sIPAddress[UINT#24] := '192.168.250.125';
38    sIPAddress[UINT#25] := '192.168.250.126';
39    sIPAddress[UINT#26] := '192.168.250.127';
40    sIPAddress[UINT#27] := '192.168.250.128';
41    sIPAddress[UINT#28] := '192.168.250.129';
42    sIPAddress[UINT#29] := '192.168.250.130';
43    sIPAddress[UINT#30] := '192.168.250.131';
44    sIPAddress[UINT#31] := '192.168.250.132';
45    sIPAddress[UINT#32] := '192.168.250.133';
46    sIPAddress[UINT#33] := '192.168.250.134';
47    sIPAddress[UINT#34] := '192.168.250.135';
48    sIPAddress[UINT#35] := '192.168.250.136';
49    sIPAddress[UINT#36] := '192.168.250.137';
50    sIPAddress[UINT#37] := '192.168.250.138';
51    sIPAddress[UINT#38] := '192.168.250.139';
52    sIPAddress[UINT#39] := '192.168.250.140';
53    sIPAddress[UINT#40] := '192.168.250.141';
54    sIPAddress[UINT#41] := '192.168.250.142';
55    sIPAddress[UINT#42] := '192.168.250.143';
56    sIPAddress[UINT#43] := '192.168.250.144';
57    sIPAddress[UINT#44] := '192.168.250.145';
58    sIPAddress[UINT#45] := '192.168.250.146';
59    sIPAddress[UINT#46] := '192.168.250.147';
60    sIPAddress[UINT#47] := '192.168.250.148';
61    sIPAddress[UINT#48] := '192.168.250.149';
62    sIPAddress[UINT#49] := '192.168.250.150';
63    sIPAddress[UINT#50] := '192.168.250.151';
64    sIPAddress[UINT#51] := '192.168.250.152';
65    sIPAddress[UINT#52] := '192.168.250.153';
66    sIPAddress[UINT#53] := '192.168.250.154';
67    sIPAddress[UINT#54] := '192.168.250.155';
68    sIPAddress[UINT#55] := '192.168.250.156';
69    sIPAddress[UINT#56] := '192.168.250.157';
70    sIPAddress[UINT#57] := '192.168.250.158';
71    sIPAddress[UINT#58] := '192.168.250.159';
72    sIPAddress[UINT#59] := '192.168.250.160';
73    sIPAddress[UINT#60] := '192.168.250.161';
74    sIPAddress[UINT#61] := '192.168.250.162';
75    sIPAddress[UINT#62] := '192.168.250.163';
76    sIPAddress[UINT#63] := '192.168.250.164';
77    sIPAddress[UINT#64] := '192.168.250.165';
78    sIPAddress[UINT#65] := '192.168.250.166';
79    sIPAddress[UINT#66] := '192.168.250.167';
80    sIPAddress[UINT#67] := '192.168.250.168';
81    sIPAddress[UINT#68] := '192.168.250.169';
82    sIPAddress[UINT#69] := '192.168.250.170';
83    sIPAddress[UINT#70] := '192.168.250.171';
84    sIPAddress[UINT#71] := '192.168.250.172';
85    sIPAddress[UINT#72] := '192.168.250.173';
86    sIPAddress[UINT#73] := '192.168.250.174';
87    sIPAddress[UINT#74] := '192.168.250.175';
88    sIPAddress[UINT#75] := '192.168.250.176';
89    sIPAddress[UINT#76] := '192.168.250.177';
90    sIPAddress[UINT#77] := '192.168.250.178';
91    sIPAddress[UINT#78] := '192.168.250.179';
92    sIPAddress[UINT#79] := '192.168.250.180';
93    sIPAddress[UINT#80] := '192.168.250.181';
94    sIPAddress[UINT#81] := '192.168.250.182';
95    sIPAddress[UINT#82] := '192.168.250.183';
96    sIPAddress[UINT#83] := '192.168.250.184';
97    sIPAddress[UINT#84] := '192.168.250.185';
98    sIPAddress[UINT#85] := '192.168.250.186';
99    sIPAddress[UINT#86] := '192.168.250.187';
100   sIPAddress[UINT#87] := '192.168.250.188';
101   sIPAddress[UINT#88] := '192.168.250.189';
102   sIPAddress[UINT#89] := '192.168.250.190';
103   sIPAddress[UINT#90] := '192.168.250.191';
104   sIPAddress[UINT#91] := '192.168.250.192';
105   sIPAddress[UINT#92] := '192.168.250.193';
106   sIPAddress[UINT#93] := '192.168.250.194';
107   sIPAddress[UINT#94] := '192.168.250.195';
108   sIPAddress[UINT#95] := '192.168.250.196';
109   sIPAddress[UINT#96] := '192.168.250.197';
110   sIPAddress[UINT#97] := '192.168.250.198';
111   sIPAddress[UINT#98] := '192.168.250.199';
112   sIPAddress[UINT#99] := '192.168.250.200';
113
114   // set enable status (for the number of data collection units)
115   Clear(bEnable);
116   FOR IWk1 := UINT#0 TO INumOfUnits - UINT#1 BY UINT#1 DO
117     bEnable[Wk1] := TRUE;
118   END_FOR;
119
120   // set the first cycle flag
121   bTimeMess := FALSE;
122   bFirstOutput := TRUE;
123   bFirstOutputDone := FALSE;
124   bOutput := FALSE;

```

[Initial setting] INumOfUnits
 Sets the number of K6CM devices to be used (up to 100 can be set).
 If it is set more than the number to be used, wait time will be generated at initial setting, so set it according to the actual number to be used.

[Initial setting] IRetryValue
 Sets the number of retries at communications error between the PLC and the K6CM devices. (Initial value: 1)

In the initial state, it is set to 0. Therefore, the collected data of the device that caused the communications error is treated as unmeasured, so communications are not retried. This makes it possible to prioritize the data collection cycle.
 On the other hand, if you increase the number of retries, communications will be retried on basis of the set number of times even if communications error occurs. This makes it possible to prioritize the data collection of the device. However, the data collection cycle should also be longer because the waiting time becomes longer.

[Initial setting] IOutputCycle
 Sets the data collection cycle. (Initial value: 30 s)

If the number of retries or the CIP timeout value is increased from the initial value and a communications error occurs in that state, the waiting time will be longer. As a result, the data collection processing may not be completed within the data collection cycle.
 Calculate the maximum waiting time using the following calculation formula and then set a data collection cycle larger than the calculation result.
 Maximum waiting time [sec] = (CIP timeout time × 4) × (1 + communications retry count) × number of cycles + CSV output time
 * The number of cycles is an integer (the decimal point is rounded up) obtained by dividing the number of data collection devices by the number of parallel connection.
 Example: calculation with initial value
 Maximum waiting time = (1 × 4) × (1 + 1) × (20 + 10) + 4 = 20 s → The data collection cycle requires 10 s or more with a margin

[Initial setting] INumOfParallel
 Sets the number of K6CM devices to be connected (i.e., communicate) with the PLC at one time. (Initial value: 10)

In this program, it is assumed that the number of connections at one time is 10 or less, and it is not normally necessary to change from the initial value, but if you incorporate this program into another program, change it as necessary.
 In that case, note that the maximum number of clients that PLC can communicate at one time is 32.
 In the K6CM-dedicated FB (K6CM_Read), a total of three communications processes are executed one by one for a K6CM device, so the number of clients per K6CM device is one.

[Initial setting] ICIPTimeOut
 Sets the timeout value of the CIP communications command issued by the CIP-dedicated FB.
 (Initial value: 10)

Normally, there is no problem with the initial value. However, the value to be set varies depending on the user system, so change it as necessary.

[Initial setting] sIPAddress
 Set the IP address of K6CM devices to be used in advance. Set in order from the top of the program for the number to be used.

Example: Using three devices of 192.168.250.121 to 192.168.250.123
 sIPAddress [UINT # 0] := '192.168.250.121';
 sIPAddress [UINT # 1] := '192.168.250.122';
 sIPAddress [UINT # 2] := '192.168.250.123';
 sIPAddress [UINT # 3] := '192.168.250.104'; ← No need to change IP address after this
 sIPAddress [UINT # 4] := '192.168.250.105'; ← (however, setting is required below)
 * Set the number of collecting devices on line number106 to "3".
 → INumOfUnits := UINT # 3; // number of collected devices

```

125     bOutputAgain := FALSE;
126     bInitUnitConf := TRUE;
127     bTimeUp := FALSE;
128     bCollecting := FALSE;
129 END_IF;
130
131 IF ( bInitUnitConf = TRUE ) THEN
132 // get current time and date --> make CSV file name (K6CM_YYYYMMDD-hhmm.CSV)
133 dtStartTime := GetTime();
134 dtToDateStruct(dtStartTime, stStartTime);
135 sFileName := CONCAT('K6CM_', USINT_TO_STRING(stStartTime.Year));
136 sWkStr := CONCAT('0', USINT_TO_STRING(stStartTime.Month));
137 sFileName := CONCAT(sFileName, RIGHT(sWkStr, 2));
138 sWkStr := CONCAT('0', USINT_TO_STRING(stStartTime.Day));
139 sFileName := CONCAT(sFileName, RIGHT(sWkStr, 2), '-');
140 sWkStr := CONCAT('0', USINT_TO_STRING(stStartTime.Hour));
141 sFileName := CONCAT(sFileName, RIGHT(sWkStr, 2));
142 sWkStr := CONCAT('0', USINT_TO_STRING(stStartTime.Min));
143 sFileName := CONCAT(sFileName, RIGHT(sWkStr, 2), '.CSV');
144 END_IF;
145
146 insF_TRIG_FirstOut( Ck := bFirstOutput, Q => bFirstOutput_pls );
147 IF bFirstOutput_pls = TRUE THEN
148     bFirstOutputDone := TRUE;
149 END_IF;
150
151 // generate time up signal every data cycle time
152 IF ( P_First_Run = FALSE ) AND ( bTimeUp = FALSE ) THEN
153     bTimeMeas := TRUE;
154 END_IF;
155 IF ( P_First_Run = FALSE ) AND ( bTimeMeas = FALSE ) THEN
156     bInitUnitConf := FALSE;
157 END_IF;
158
159 insTON(
160     In := bTimeMeas,
161     PT := tOutputCycle, // data collection cycle time
162     Q => bTimeUp );
163
164 // down the flag of collecting during time up of data collection
165 IF ( bTimeUp = TRUE ) THEN
166 // Devices carried over to the next cycle during FB processing or retry are treated as retry over
167 FOR iWk1 := iUNIT#0 TO iNumOfUnits - iUNIT#1 BY iUNIT#1 DO
168     IF iStatus[ iWk1 ] = iUNIT#1 OR iStatus[ iWk1 ] = iUNIT#2 THEN
169         iStatus[ iWk1 ] := iUNIT#4;
170         IF iProCode[ iWk1 ] = iUNIT#0 THEN // regard it as an invalid device if its product code has not been acquired
171             bEnable[ iWk1 ] := FALSE;
172         END_IF;
173     ELSE
174         iStatus[ iWk1 ] := iUNIT#0;
175     END_IF;
176 END_FOR;
177
178     bCollecting := FALSE;
179     bTimeMeas := FALSE;
180 END_IF;
181
182 // raise the flag of collecting during measuring of time up ( bTimeMeas --> TRUE )
183 insR_TRIG( Ck := bTimeMeas, Q => bTimeMeas_pls );
184 IF ( bTimeMeas_pls = TRUE ) THEN
185     Clear(bExecute);
186     Clear(wErrID);
187     Clear(iSelectableUNIT);
188     Clear(iRetryCnt);
189     Clear(stRespServiceDat);
190     bCollecting := TRUE;
191     bOutput := FALSE;
192 END_IF;
193
194 // status handling of data collection
195 IF ( bCollecting = FALSE ) THEN
196
197 // off the K6CM FB except during data collection
198 FOR iWk1 := iUNIT#0 TO iNumOfParallel - iUNIT#1 BY iUNIT#1 DO
199     bExecute[ iWk1 ] := FALSE;
200 END_FOR;
201
202 ELSE
203
204 // K6CM FB execution setting 1 ( initialize index of execution target unit )
205 FOR iWk1 := iUNIT#0 TO iNumOfParallel - iUNIT#1 BY iUNIT#1 DO
206     IF ( iSelectableUNIT[ iWk1 ] < iWk1 ) THEN
207         iSelectableUNIT[ iWk1 ] := iWk1; // set initial value if initial status
208     END_IF;
209 END_FOR;
210
211 // K6CM FB execution setting 2 ( update index of next execution unit )
212 FOR iWk1 := iUNIT#0 TO iNumOfParallel - iUNIT#1 BY iUNIT#1 DO
213
214 // fix the status if invalid node
215 IF ( bEnable[ iSelectableUNIT[ iWk1 ] ] = FALSE ) THEN
216     iStatus[ iSelectableUNIT[ iWk1 ] ] := iUNIT#4;
217     bExecute[ iWk1 ] := FALSE;
218 END_IF;
219
220 // retry at abnormal completion with flag handled ( return temporary to untreated status )
221 IF ( iStatus[ iSelectableUNIT[ iWk1 ] ] = iUNIT#2 ) THEN
222     IF ( bExecute[ iWk1 ] = FALSE ) AND ( bEnable[ iWk1 ] = TRUE ) THEN
223         iStatus[ iSelectableUNIT[ iWk1 ] ] := iUNIT#0;
224     END_IF;
225 END_IF;
226
227 // search next untreated unit if successful completion or retry-over
228 IF ( iStatus[ iSelectableUNIT[ iWk1 ] ] = iUNIT#3 OR iStatus[ iSelectableUNIT[ iWk1 ] ] = iUNIT#4 ) THEN
229     IF ( bExecute[ iWk1 ] = FALSE ) THEN
230 // search next untreated unit
231 FOR iWk2 := iUNIT#0 TO iNumOfUnits - iUNIT#1 BY iUNIT#1 DO
232     IF ( iStatus[ iWk2 ] = iUNIT#0 AND bEnable[ iWk2 ] = TRUE ) THEN // search condition: untreated and not being treated on other session
233         FOR iWk3 := iUNIT#0 TO iNumOfParallel - iUNIT#1 BY iUNIT#1 DO
234             IF ( iSelectableUNIT[ iWk3 ] = iWk2 ) THEN
235                 EXIT;
236             END_IF;
237         END_FOR;
238         IF ( iWk3 = iNumOfParallel ) THEN
239             iSelectableUNIT[ iWk1 ] := iWk2;
240             EXIT;
241         END_IF;
242     END_FOR;
243 END_IF;
244 END_IF;
245
246 // when abnormal completion with flag unhandled
247 IF ( iStatus[ iSelectableUNIT[ iWk1 ] ] = iUNIT#2 ) THEN

```

During the data collection cycle (tOutputCycle, set bTimeMeas (i.e., data collection in progress) to TRUE during time up measurement. Once the data collection cycle has passed, set the time-up measurement in progress to FALSE once and set the time-up measurement to TRUE again during the data collection cycle.

When time-up measurement in progress bTimeMeas is TRUE, set the data collection in progress flag bTimeMeas_pls to TRUE. When the time-up measurement in progress flag is TRUE, set the bCollecting during data collection to TRUE.

When data collection in progress bCollecting is TRUE, set the FB execution command bExecute to TRUE according to the device processing state iStatus. (The data collection status is held for each device)

Device processing state

0: Indicates that the data collection target is unprocessed.
 If it is an unprocessed and valid state (bEnable = TRUE), the FB execution instruction is set to TRUE.

1: Indicates that data is being collected during processing.

2: Indicates that an error occurred in error data collection. Set the FB execution command to FALSE, add the number of retry times, and retry communications (once return the device processing state to 0).

3: Indicates that completion data collection is completed. Set the FB execution command to FALSE and search for the next unprocessed device.

4: Indicates that the upper limit of the retryover communications retry count has been reached. Search for the next unprocessed device.

```

248] IF ( bExecute[ iWk1 ] = TRUE ) THEN
249]   // off the execute flag temporarily
250]   bExecute[ iWk1 ] := FALSE;
251]   IF ( iRetryCnt[ iSelectableUNIT[ iWk1 ] ] >= iRetryValue ) THEN // when retry over
252]     IF ( iUnitConf = TRUE ) THEN
253]       bEnable[ iSelectableUNIT[ iWk1 ] ] := FALSE; // disable the node if retry over at the first collectio
254]     END_IF;
255]     iStatus[ iSelectableUNIT[ iWk1 ] ] := UINT#4;
256]   ELSE
257]     iRetryCnt[ iSelectableUNIT[ iWk1 ] ] := iRetryCnt[ iSelectableUNIT[ iWk1 ] ] + UINT#1; // add count of retry
258]   END_IF;
259] END_IF;
260] // when successful completion with flag unhandled
261] IF ( iStatus[ iSelectableUNIT[ iWk1 ] ] = UINT#3 ) THEN
262]   IF ( bExecute[ iWk1 ] = TRUE ) THEN
263]     // off the execute flag temporarily
264]     bExecute[ iWk1 ] := FALSE;
265]     // if product code is not applicable units, remove it as object of execution
266]     IF ( iUnitConf = TRUE ) THEN
267]       IF ( iProCode[ iSelectableUNIT[ iWk1 ] ] = UINT#0 ) THEN
268]         bEnable[ iSelectableUNIT[ iWk1 ] ] := FALSE;
269]       END_IF;
270]     END_IF;
271]   END_IF;
272] END_IF;
273] END_IF;
274]
275] END_FOR;
276]
277] // setting of bExecute
278] FOR iWk1 := UINT#0 TO iNumOfParallel - UINT#1 BY UINT#1 DO
279]   // raise the flag of FB execution if untreated and effective status
280]   IF ( iStatus[ iSelectableUNIT[ iWk1 ] ] = UINT#0 AND bEnable[ iSelectableUNIT[ iWk1 ] ] = TRUE ) THEN
281]     IF ( bExecute[ iWk1 ] = FALSE ) THEN
282]       bExecute[ iWk1 ] := TRUE;
283]     END_IF;
284]   END_IF;
285] END_FOR;
286]
287] // finish data collecting (= begin CSV making) if all units are successful completion or retry over
288] FOR iWk1 := UINT#0 TO iNumOfUnits - UINT#1 BY UINT#1 DO
289]   IF ( bEnable[ iWk1 ] = TRUE ) AND ( iStatus[ iWk1 ] <= UINT#2 ) THEN
290]     EXIT;
291]   END_IF;
292] END_FOR;
293] IF ( iWk1 = iNumOfUnits ) THEN
294]   bCollecting := FALSE;
295] END_IF;
296]
297] END_IF;
298]
299] // K6CM data collection FB execution
300] FOR iWk1 := UINT#0 TO iNumOfParallel - UINT#1 BY UINT#1 DO
301]
302]   insK6CM_Read[ iWk1 ](
303]     Execute := bExecute[ iWk1 ],
304]     IPAddress := sIPAddress[ iSelectableUNIT[ iWk1 ] ],
305]     Timeout := iCIPTimeOut,
306]     Done => bDone[ iWk1 ],
307]     Busy => bBusy[ iWk1 ],
308]     Error => bError[ iWk1 ],
309]     ErrorID := wErrID[ iSelectableUNIT[ iWk1 ] ],
310]     ErrorIDEx => dwErrIDEx[ iSelectableUNIT[ iWk1 ] ],
311]     ProductCode => iProCodeWk,
312]     RespServiceDat => stRespServiceDat[ iSelectableUNIT[ iWk1 ] ] );
313]
314]   // status setting along result of FB execution
315]   // executing
316]   IF ( bBusy[ iWk1 ] = TRUE ) THEN
317]     iStatus[ iSelectableUNIT[ iWk1 ] ] := UINT#1;
318]   END_IF;
319]   // successful completion
320]   IF ( bDone[ iWk1 ] = TRUE ) THEN
321]     iStatus[ iSelectableUNIT[ iWk1 ] ] := UINT#3;
322]     IF ( iUnitConf = TRUE ) THEN
323]       iProCode[ iSelectableUNIT[ iWk1 ] ] := iProCodeWk;
324]     END_IF;
325]   END_IF;
326]   // abnormal completion
327]   IF ( bError[ iWk1 ] = TRUE ) THEN
328]     iStatus[ iSelectableUNIT[ iWk1 ] ] := UINT#2;
329]   END_IF;
330] END_FOR;
331]
332] // data collection complete of all units -> raise the flag of CSV output
333] insF_TRIG( Ck := bCollecting, Q => bCollecting_pls );
334] IF ( bCollecting_pls = TRUE ) THEN
335]   bOutput := TRUE;
336]   iOutputSeq := UINT#0;
337] END_IF;
338]
339] // output the data headers to CSV
340] IF ( bOutput = TRUE ) AND ( iUnitConf = FALSE ) THEN
341]   CASE iOutputSeq OF
342]
343]     // instance initialization
344]     UINT#0:
345]       insFileOpen( Execute := FALSE );
346]       insFilePuts( Execute := FALSE );
347]       insFileClose( Execute := FALSE );
348]       IF bCollecting = FALSE THEN
349]         iOutputSeq := UINT#1;
350]       END_IF;
351]

```

In accordance with the above status processing result, the K6CM-dedicated FB is called for each device.
The collected data is stored in stRespServiceDat.

From here on, it is CSV file output processing.

For the subsequent codes, refer to the actual sample program.

9

Monitoring and Setting Using the Modbus TCP Devices

K6CM can also be monitored or set using Modbus TCP compatible devices. This section describes how to monitor using the Modbus TCP.

9-1	Outline	9-2
9-2	Function Codes	9-3
9-2-1	Function Code List	9-3
9-2-2	03 hex: Reading of Multiple Registers	9-3
9-2-3	06 hex: Operation Command	9-5
9-2-4	10 hex: Writing of Multiple Registers	9-6
9-2-5	Exception Code List	9-7
9-3	Register Address Lists	9-8
9-3-1	Monitoring Information	9-8
9-3-2	Setting Information	9-12
9-3-3	Product Information	9-18
9-3-4	IP Address	9-18
9-3-5	Operation Command	9-19
9-3-6	Modbus TCP Connection Timeout Time	9-19

9-1 Outline

This section provides an overview of how to monitor the K6CM using the Modbus TCP.

Modbus TCP is a communications protocol that uses TCP/IP to communicate with host devices such as PLCs.

This communications protocol allows host devices with a TCP/IP socket interface to read and write the internal data of the K6CM.

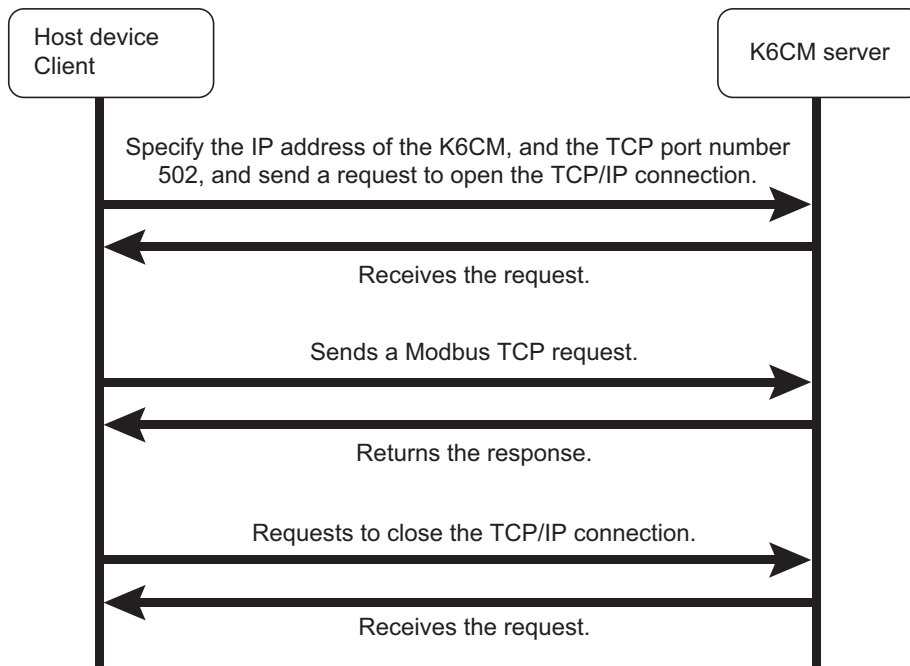
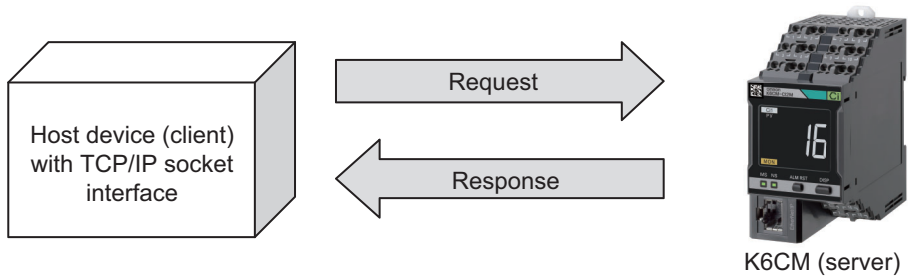

Note The socket is an interface for using TCP directly from the user program. The host device specifies the IP address of K6CM and TCP port number of 502 (01F6 hex) and opens the socket in Active. After that, it sends Modbus TCP request and reads and writes the internal data of the K6CM.

In addition, Modbus TCP can be connected to up to two clients simultaneously.

9-2 Function Codes

This section describes function codes that can be used with Modbus TCP.

9-2-1 Function Code List

The function codes that can be used are as follows.

Function code	Name	Usages
03 hex	Reading of multiple registers	Used to read the monitor information, setting information, production information, IP address, etc.
06 hex	Operation command	Used to instruct Software reset and Max./min. reset.
10 hex	Writing of multiple registers	Used to set the IP address, K6CM initial setting, etc.

9-2-2 03 hex: Reading of Multiple Registers

This function can read the contents of multiple registers starting from the specified address.

Frame Configurations

The frame configurations of Modbus TCP are as follows.

● Request

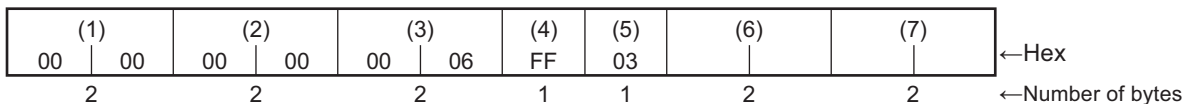

- (1): Transaction ID Specify any value. For example, 0000 hex is used in this explanation.
- (2): Protocol ID Specify 0000 hex.
- (3): Number of bytes transferred Specify the total number of bytes of (4) and the successor. In the above case, it is from (4) to (7), so it is 0006 hex.
- (4): Unit ID Specify FF hex.
- (5): Function code Specify 03 hex (Reading of multiple registers).
- (6): Start address Specify the address to start reading.
Refer to 9-3 Register Address Lists on page 9-8.
- (7): Number of words to read Specify the number of words of the register to be read. The maximum value is 26 (001A hex).

● Normal Response

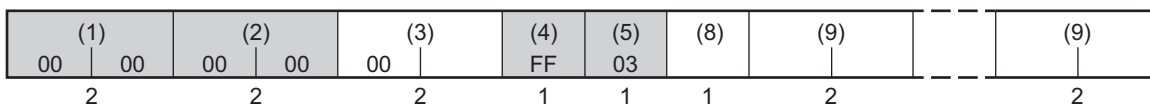

● Error Response

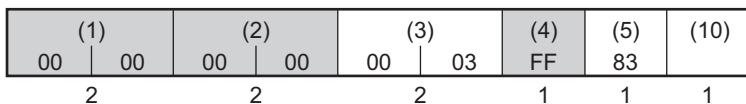

- (3): Number of bytes transferred The total number of bytes of (4) and the successor is set.
- (8): Byte count The total number of bytes of (9) is set.
- (9): Register contents Register contents from the start address to the number of read words are set.
- (10): Exception code Error information is set. Refer to 9-2-5 Exception Code List on page 9-7.

Note 1. For the other elements (the elements shaded in the above figure), the value specified in the request is set.
 2. The function code of (5) at error response is 83 hex.

Example: Reading the Main Body Status

● Request

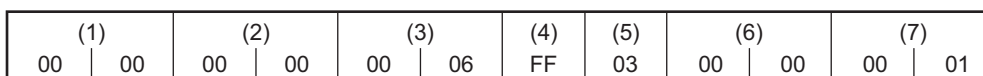

- (6): Start address Specify the address of the main body status.
- (7): Number of words to read The entire Main body status is 1 word (2 bytes), so specify 0001 hex.

● Normal Response

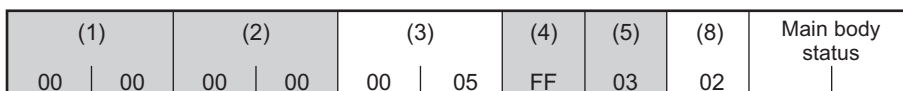

- (3): Number of bytes transferred The total number of bytes of (4) and the successor are 5, so 0005 hex is set.
- (8): Byte count The Main body status is 2 bytes, so 02 hex is set.

Note For the other elements (the elements shaded in the above figure), the value specified in the request is set.

9-2-3 06 hex: Operation Command

This command executes Software reset and Max./min. reset.

Frame Configurations

The frame configurations of Modbus TCP are as follows.

● Request

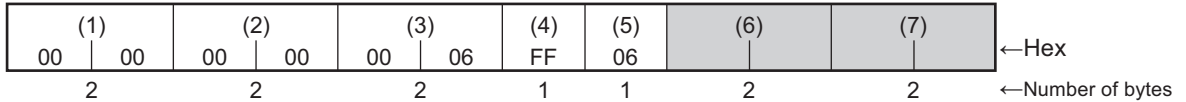

- (1): Transaction ID Specify any value. For example, 0000 hex is used in this explanation.
- (2): Protocol ID Specify 0000 hex.
- (3): Number of bytes transferred Specify the total number of bytes of (4) and the successor. In the above case, it is from (4) to (7), so it is 0006 hex.
- (4): Unit ID Specify FF hex.
- (5): Function code Specify 06 hex (Operation command).
- (6): Start address Specify D000 hex (Software reset) or D001 hex (Max./min. reset).
- (7): Number of words to read Specify 0001 hex (common for Software reset and Max./min. reset).

● Normal Response

It is the same as the request.

● Error Response

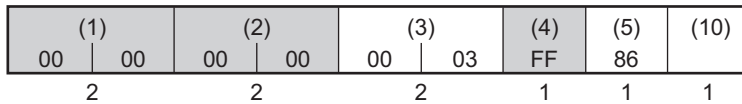

- (3): Number of bytes transferred The total number of bytes of (4) and the successor is set.
- (5): Function code 86 hex is set.
- (10): Exception code Error information is set. Refer to 9-2-5 *Exception Code List* on page 9-7.

Note For the other elements (the elements shaded in the above figure), the value specified in the request is set.

9-2-4 10 hex: Writing of Multiple Registers

This function can write data to multiple registers with the specified address as the start address.

Frame Configurations

The frame configurations of Modbus TCP are as follows.

● Request

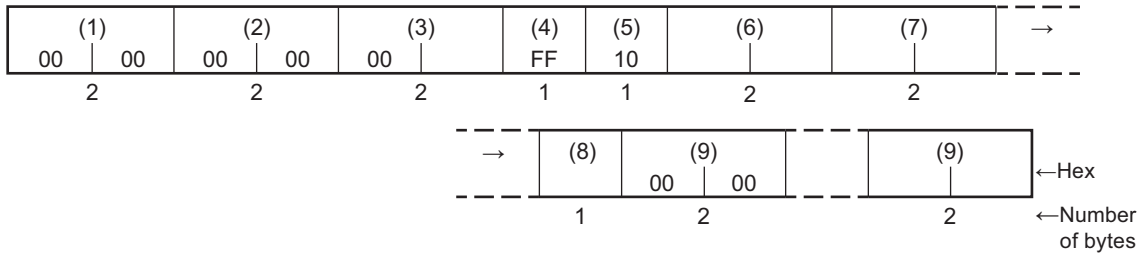

- (1): Transaction ID Specify any value. For example, 0000 hex is used in this explanation.
- (2): Protocol ID Specify 0000 hex.
- (3): Number of bytes transferred Specify the total number of bytes of (4) and the successor.
- (4): Unit ID Specify FF hex.
- (5): Function code 10 hex (Writing of multiple registers) is specified.
- (6): Start address Specify the address to start writing.
- (7): Number of words to read Specify the number of words of the register to be write. The maximum value is 24 (0018 hex). Refer to 9-3 Register Address Lists on page 9-8.
- (8): Byte count Specify the total number of bytes of (9).
- (9): Data Register contents from the start address to the number of write words are set.

● Normal Response

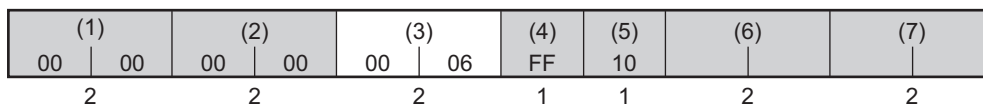

● Error Response

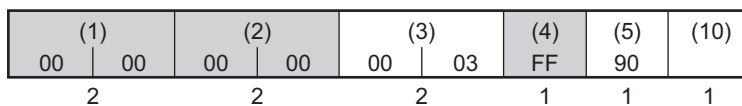

- (3): Number of bytes transferred The total number of bytes of (4) and the successor is set.
- (10): Exception code Error information is set. Refer to 9-2-5 Exception Code List on page 9-7.

Note 1. The elements shaded in the above figures are set to the value specified in the request.

2. The function code of (5) at error response is 90 hex.

Example: Change IP Address

● Request

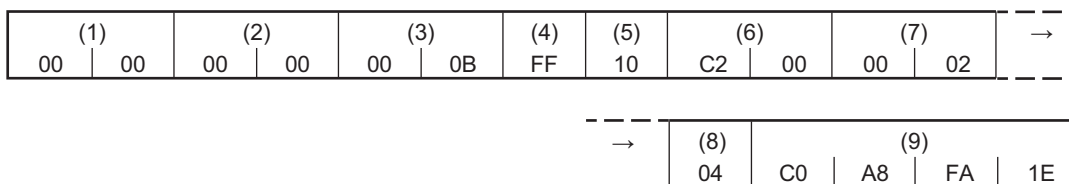

- (1): Transaction ID Specify any value. For example, 0000 hex is used in this explanation.
- (2): Protocol ID Specify 0000 hex.
- (3): Number of bytes transferred The total number of bytes of (4) and the successor are 11, so specify 000B hex.
- (4): Unit ID Specify FF hex.
- (5): Function code 10 hex (Writing of multiple registers) is specified.
- (6): Start address Specify the register address of the IP address.
- (7): Number of words to read The IP address is 2 words (4 bytes), so specify 0002 hex.
- (8): Byte count The total number of bytes of (9) is 4 bytes, so specify 04 hex.
- (9): Data Specify 192.168.250.10 (C0 A8 FA 0A hex) as the IP address.

● Normal Response

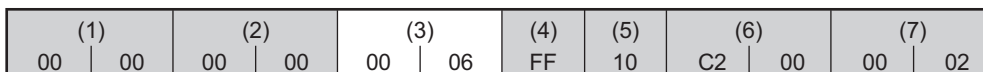

- (3): Number of bytes transferred The total number of bytes of (4) and the successor are 6, so 0006 hex is set.

Note For the other elements (the elements shaded in the above figure), the value specified in the request is set.

9-2-5 Exception Code List

The following is the exception codes when an error response occurs. Confirm this content and review the request.

Exception code	Types of error	Function
01 hex	Illegal function codes	In the case of an unsupported function code.
02 hex	Illegal data address	When an address that cannot be read or written is included.
03 hex	Illegal data value	When data that cannot be written, such as data that is outside the setting range, is included.
04 hex	Failure in associated device	This is the state in which normal execution cannot be performed. <ul style="list-style-type: none"> When K6CM is an error state. When an operation command and writing of multiple registers cannot be performed. Refer to 9-3 <i>Register Address Lists</i> on page 9-8 for details.

9-3 Register Address Lists

Registers that can be read and written using Modbus TCP are as follows.

Offset address (hexadecimal)	Contents (communications area)	R/W
0000 to 0015 hex	Monitoring information	R
A000 to A017 hex	Setting information	R/W
C000 to C019 hex	Product information	R
C200 to C207 hex	IP address	R/W
D000 to D001 hex	Operation command	W
F300 hex	Modbus TCP connection timeout time	R/W

9-3-1 Monitoring Information

● Common to K6CM

Address	Parameter name	Description	Number of bytes	R/W*1
0000 hex	Mes cpu version	Measurement part version	2	R
0001 hex	Main cpu version	Main part version	2	R
0002 hex	Eip cpu version	EtherNet/IP part version	2	R
0003 hex	Main body status	Refer to "Main body status" in 8-3-3 <i>Monitor Object (Class ID: 370 hex)</i> on page 8-13.	2	R
0004 hex	Running Time	Coefficient indicating lifetime of the K6CM device based on the product of operation time and internal temperature. 0000 to 0064 hex	2	R
0005 hex	Number of Triggers	Displays the total number of integration times of the trigger. Increase the number of triggers by +1 every 100 iterations of starting measuring and monitoring. 0 to 65535	2	R

*1. R: Read using Reading of multiple registers (03 hex).

● **Comprehensive current diagnosis type (K6CM-CI2M)**

Address	Parameter name	Description	Number of bytes	R/W*1
0006 hex	Current status	Refer to "Measurement status" in 8-3-3 Monitor Object (Class ID: 370 hex) on page 8-13.	2	R
0007 hex	Current pv	Measurement value of current pv	2	R
0008 hex	Current min.	Measurement value of current min.	2	R
0009 hex	Current max.	Measurement value of current max.	2	R
000A hex	Degradation level 1 status	Refer to <i>Comprehensive current diagnosis type (K6CM-CI2M)</i> on page 8-15 under 8-3-3 Monitor Object (Class ID: 370 hex) on page 8-13.	2	R
000B hex	Degradation level 1 pv	Measurement value of degradation level 1 pv	2	R
000C hex	Degradation level 1 min.	Measurement value of degradation level 1 min.	2	R
000D hex	Degradation level 1 max.	Measurement value of degradation level 1 max.	2	R
000E hex	Degradation level 2 status	Refer to <i>Comprehensive current diagnosis type (K6CM-CI2M)</i> on page 8-15 under 8-3-3 Monitor Object (Class ID: 370 hex) on page 8-13.	2	R
000F hex	Degradation level 2 pv	Measurement value of degradation level 2 pv	2	R
0010 hex	Degradation level 2 min.	Measurement value of degradation level 2 min.	2	R
0011 hex	Degradation level 2 max.	Measurement value of degradation level 2 max.	2	R
0012 to 0015 hex	Reserved area	Reserved area	2	R

*1. R: Read using Reading of multiple registers (03 hex).

● **Vibration & temperature type (K6CM-VBM)**

Address	Parameter name	Description	Number of bytes	R/W*1
0006 hex	Acceleration status	Refer to <i>Vibration & temperature type (K6CM-VBM)</i> on page 8-16 under <i>8-3-3 Monitor Object (Class ID: 370 hex)</i> on page 8-13.	2	R
0007 hex	Acceleration pv	Measurement value of acceleration pv	2	R
0008 hex	Acceleration min.	Measurement value of acceleration min.	2	R
0009 hex	Acceleration max.	Measurement value of acceleration max.	2	R
000A hex	Velocity status	Refer to <i>Vibration & temperature type (K6CM-VBM)</i> on page 8-16 under <i>8-3-3 Monitor Object (Class ID: 370 hex)</i> on page 8-13.	2	R
000B hex	Velocity pv	Measurement value of velocity pv	2	R
000C hex	Velocity min.	Measurement value of velocity min.	2	R
000D hex	Velocity max.	Measurement value of velocity max.	2	R
000E hex	Motor temperature status	Refer to <i>Vibration & temperature type (K6CM-VBM)</i> on page 8-16 under <i>8-3-3 Monitor Object (Class ID: 370 hex)</i> on page 8-13.	2	R
000F hex	Motor temperature pv	Measurement value of motor temperature pv	2	R
0010 hex	Motor temperature min.	Measurement value of motor temperature min.	2	R
0011 hex	Motor temperature max.	Measurement value of motor temperature max.	2	R
0012 hex	Temperature gap status	Refer to <i>Vibration & temperature type (K6CM-VBM)</i> on page 8-16 under <i>8-3-3 Monitor Object (Class ID: 370 hex)</i> on page 8-13.	2	R
0013 hex	Temperature gap pv	Measurement value of temperature gap pv	2	R
0014 hex	Temperature gap min.	Measurement value of temperature gap min.	2	R
0015 hex	Temperature gap max.	Measurement value of temperature gap max.	2	R

*1. R: Read using Reading of multiple registers (03 hex).

● Insulation resistance type (K6CM-ISM)

Address	Parameter name	Description	Number of bytes	R/W*1
0006 hex	Insulation resistance status	Refer to <i>Insulation resistance type (K6CM-ISM)</i> on page 8-17 under <i>8-3-3 Monitor Object (Class ID: 370 hex)</i> on page 8-13.	2	R
0007 hex	Insulation resistance pv	Measurement value of insulation resistance pv	2	R
0008 hex	Insulation resistance min.	Measurement value of insulation resistance min.	2	R
0009 hex	Insulation resistance max.	Measurement value of insulation resistance max.	2	R
000A hex	I0r status	Refer to <i>Insulation resistance type (K6CM-ISM)</i> on page 8-17 under <i>8-3-3 Monitor Object (Class ID: 370 hex)</i> on page 8-13.	2	R
000B hex	I0r pv	Measurement value of I0r pv	2	R
000C hex	I0r min.	Measurement value of I0r min.	2	R
000D hex	I0r max.	Measurement value of I0r max.	2	R
000E hex	I0c status	Refer to <i>Insulation resistance type (K6CM-ISM)</i> on page 8-17 under <i>8-3-3 Monitor Object (Class ID: 370 hex)</i> on page 8-13.	2	R
000F hex	I0c pv	Measurement value of I0c pv	2	R
0010 to 0015 hex	Reserved area	Reserved area	2	R

*1. R: Read using Reading of multiple registers (03 hex).

9-3-2 Setting Information

● Comprehensive current diagnosis type (K6CM-CI2M)

Address	Parameter name	Description	Number of bytes	R/W ^{*1}	Initial value
A000 hex	Display value type	Sets which measurement value is displayed in the 7 segment display on the front of the K6CM device. 0: PV (Present value) 1: MIN 2: MAX	2	R/W	0000 hex
A001 hex	Trigger mode	Selects the trigger mode. 0: Free run 1: External trigger 2: Internal trigger	2	R/W	0000 hex
A002 hex	Trigger type	Set the trigger measurement start condition. Setting is not required when the trigger mode is "Free run". 0: Rising edge 1: Falling edge 2: Level	2	R/W	0000 hex
A003 hex	Trigger level	For "Internal trigger", set the measurement value to start trigger measurement. Setting is not required when the trigger mode is "Free run" or "External trigger". Note : Unit and decimal point position follow measurement values. (Refer to A-6 <i>Internal Data of K6CM Devices</i> on page A-14.)	2	R/W	0000 hex
A004 hex	Monitoring time	Sets the monitoring time. 1 to 6000 (unit: 0.1 seconds) (0001 to 1770 hex)	2	R/W	0001 hex
A005 hex	Alarm latch	Sets enable/disable of alarm latch function. 0: Disable (no latch) 1: Enable (with latch)	2	R/W	0001 hex
A006 hex	Use Running Time	Set the function to detect the life of the K6CM device. 0: OFF (not used) 1: ON (use)	2	R/W	0000 hex
A007 hex	Moving average times	Every time the measurement value is sampled, the data of the past n times including the sampling data of that time is averaged. 0: OFF 1: 2 times 2: 4 times 3: 8 times 4: 16 times 5: 32 times	2	R/W	0003 hex

Address	Parameter name	Description	Number of bytes	R/W*1	Initial value
A008 hex	Current range	Sets the current range. 0: 5 A 1: 25 A 2: 100 A 3: 200 A 4: 400 A 5: 600 A	2	R/W	0003 hex
A009 hex	Reserved area	Reserved area	2	R/W	0000 hex
A00A hex	Reserved area	Reserved area	2	R/W	0000 hex
A00B hex	Current failure warning	Sets the current failure warning threshold. 0 to 9999 (Unit in the 5 A range: 0.01 A) (Unit in other ranges: 0.1 A) (0000 to 270F hex)	2	R/W	07D0 hex (2000)
A00C hex	Current failure critical	Sets the current failure critical threshold. 0 to 9999 (Unit in the 5 A range: 0.01 A) (Unit in other ranges: 0.1 A) (0000 to 270F hex)	2	R/W	07D0 hex (2000)
A00D hex	Degradation level 1 failure warning	Sets the degradation level 1 failure warning threshold. 0 to 9999 (0000 to 270F hex)	2	R/W	001E hex (30)
A00E hex	Degradation level 1 failure critical	Sets the degradation level 1 failure critical threshold. 0 to 9999 (0000 to 270F hex)	2	R/W	0032 hex (50)
A00F hex	Degradation level 2 failure warning	Sets the degradation level 2 failure warning threshold. 0 to 9999 (0000 to 270F hex)	2	R/W	0014 hex (20)
A010 hex	Degradation level 2 failure critical	Sets the degradation level 2 failure critical threshold. 0 to 9999 (0000 to 270F hex)	2	R/W	0032 hex (50)
A011 to A012 hex	Reserved area	Reserved area	2	R/W	0000 hex
A013 hex	Transistor output method	Select transistor output method. 0: Normally Close 1: Normally Open	2	R/W	0000 hex
A014 hex	Monitoring delay time	Set the delay time from the trigger input to the start of measurement. 0.0 to 6000 (unit: 0.1 seconds) (0000 to 1770 hex)	2	R/W	0000 hex

Address	Parameter name	Description	Number of bytes	R/W ^{*1}	Initial value
A015 hex	Current moving average times	Set the current moving average times. 0: OFF 1: 2 times 2: 4 times 3: 8 times 4: 16 times 5: 32 times	2	R/W	0000 hex
A016 hex	Degradation level 1 moving average times	Set the degradation level 1 moving average times. 0: OFF 1: 2 times 2: 4 times 3: 8 times 4: 16 times 5: 32 times	2	R/W	0003 hex
A017 hex	Degradation level 2 moving average times	Set the degradation level 2 moving average times. 0: OFF 1: 2 times 2: 4 times 3: 8 times 4: 16 times 5: 32 times	2	R/W	0000 hex

*1. R: Read using Reading of multiple registers (03 hex).

W: Write using writing of multiple registers (10 hex).

● Vibration & temperature type (K6CM-VBM)

Address	Parameter name	Description	Number of bytes	R/W ^{*1}	Initial value
A000 hex	Display value type	Sets which measurement value is displayed in the 7 segment display on the front of the K6CM device. 0: PV (Present value) 1: MIN 2: MAX	2	R/W	0000 hex
A001 hex	Trigger mode	Selects the trigger mode. 0: Free run 1: External trigger 2: Internal trigger	2	R/W	0000 hex
A002 hex	Trigger type	Set the trigger measurement start condition. Setting is not required when the trigger mode is "Free run". 0: Rising edge 1: Falling edge 2: Level	2	R/W	0000 hex
A003 hex	Trigger level	For "Internal trigger", set the measurement value to start trigger measurement. Setting is not required when the trigger mode is "Free run" or "External trigger". Note : Unit and decimal point position follow measurement values. (Refer to A-6 <i>Internal Data of K6CM Devices</i> on page A-14.)	2	R/W	0000 hex

Address	Parameter name	Description	Number of bytes	R/W*1	Initial value
A004 hex	Monitoring time	Sets the monitoring time. 1 to 6000 (unit: 0.1 seconds) (0001 to 1770 hex)	2	R/W	0001 hex (1)
A005 hex	Alarm latch	Sets enable/disable of alarm latch function. 0: Disable (no latch) 1: Enable (with latch)	2	R/W	0001 hex
A006 hex	Use Running Time	Sets the usage or nonuse of K6CM remaining capacity function. 0: OFF (not used) 1: ON (use)	2	R/W	0000 hex
A007 hex	Moving average times	Every time the measurement value is sampled, the data of the past n times including the sampling data of that time is averaged. 0: OFF 1: 2 times 2: 4 times 3: 8 times 4: 16 times 5: 32 times	2	R/W	0000 hex
A008 hex	Temperature unit	Sets the temperature unit. 0: °C 1: °F	2	R/W	0000 hex
A009 hex	Reserved area	Reserved area	2	R/W	0000 hex
A00A hex	Reserved area	Reserved area	2	R/W	0000 hex
A00B hex	Acceleration failure warning	Sets the acceleration failure warning threshold. 0 to 9999 (Unit: 0.01 G) (0000 to 270F hex)	2	R/W	0032 hex (50)
A00C hex	Acceleration alarm critical	Sets the acceleration failure critical threshold. 0 to 9999 (Unit: 0.01 G) (0000 to 270F hex)	2	R/W	0064 hex (100)
A00D hex	Velocity failure warning	Sets the velocity failure warning threshold. 0 to 9999 (unit: 0.01 mm/s) (0000 to 270F hex)	2	R/W	0FA0 hex (4000)
A00E hex	Velocity failure critical	Sets the velocity failure critical threshold. 0 to 9999 (unit: 0.01 mm/s) (0000 to 270F hex)	2	R/W	1194 hex (4500)
A00F hex	Motor temperature failure warning	Sets the motor temperature failure warning threshold. 0 to 9999 (unit: °C) (0000 to 270F hex)	2	R/W	0050 hex (80)
A010 hex	Motor temperature failure critical	Sets the motor temperature failure critical threshold. 0 to 9999 (unit: °C) (0000 to 270F hex)	2	R/W	0050 hex (80)

Address	Parameter name	Description	Number of bytes	R/W ^{*1}	Initial value
A011 hex	Temperature gap failure warning	Sets the temperature gap failure warning threshold. 0 to 9999 (unit: °C) (0000 to 270F hex)	2	R/W	0050 hex (80)
A012 hex	Temperature gap failure critical	Sets the temperature gap failure critical threshold. 0 to 9999 (unit: °C) (0000 to 270F hex)	2	R/W	0050 hex (80)
A013 hex	Transistor output method	Select transistor output method. 0: Normally Close 1: Normally Open	2	R/W	0000 hex
A014 hex	Monitoring delay time	Set the delay time from the trigger input to the start of measurement. 0.0 to 6000 (unit: 0.1 seconds) (0000 to 1770 hex)	2	R/W	0000 hex
A015 to A017 hex	Reserved area	Reserved area	2	R/W	0000 hex

*1. R: Read using Reading of multiple registers (03 hex).

W: Write using writing of multiple registers (10 hex).

● Insulation resistance type (K6CM-ISM)

Address	Parameter name	Description	Number of bytes	R/W ^{*1}	Initial value
A000 hex	Display value type	Sets which measurement value is displayed in the 7 segment display on the front of the K6CM device. 0: PV (Present value) 1: MIN 2: MAX	2	R/W	0000 hex
A001 hex	Trigger mode	Selects the trigger mode. 0: Free run 1: External trigger 2: Internal trigger	2	R/W	0000 hex
A002 hex	Trigger type	Set the trigger measurement start condition. Setting is not required when the trigger mode is "Free run". 0: Rising edge 1: Falling edge 2: Level	2	R/W	0000 hex
A003 hex	Trigger level	For "Internal trigger", set the measurement value to start trigger measurement. Setting is not required when the trigger mode is "Free run" or "External trigger". Note : Unit and decimal point position follow measurement values. (Refer to A-6 <i>Internal Data of K6CM Devices</i> on page A-14.)	2	R/W	0000 hex
A004 hex	Monitoring time	Sets the monitoring time. 1 to 6000 (unit: 0.1 seconds) (0001 to 1770 hex)	2	R/W	0001 hex (1)
A005 hex	Alarm latch	Sets enable/disable of alarm latch function. 0: Disable (no latch) 1: Enable (with latch)	2	R/W	0001 hex

Address	Parameter name	Description	Number of bytes	R/W*1	Initial value
A006 hex	Use Running Time	Sets the usage or nonuse of K6CM remaining capacity function. 0: OFF (not used) 1: ON (use)	2	R/W	0000 hex
A007 hex	Moving average times	Every time the measurement value is sampled, the data of the past n times including the sampling data of that time is averaged. 0: OFF 1: 2 times 2: 4 times 3: 8 times 4: 16 times 5: 32 times	2	R/W	0000 hex
A008 hex	Circuit topology	Sets the applied circuit. 0: Three-phase three-wire system, S-phase grounding 1: Three-phase four-wire system, N-phase grounding, delta connection load	2	R/W	0000 hex
A009 hex	Using inverter	Sets the presence or absence of the inverter. 0: OFF (No inverter) 1: ON (with inverter)	2	R/W	0000 hex
A00A hex	Inverter special measurement	Sets the Inverter Special measurement. 0: OFF 1: ON Special calculation to do when inverter frequency and commercial frequency are close. Note : Using inverter = "with inverter" only valid For how to use this function, refer to the <i>Wiring Diagram of the Insulation Resistance Type (K6CM-IS)</i> on page 5-27 in 5-6 I/O wiring on page 5-25.	2	R/W	0000 hex
A00B hex	Insulation resistance failure warning	Sets the insulation resistance failure warning threshold. 0 to 9999 (Unit: 0.001 MΩ) (0000 to 270F hex)	2	R/W	0320 hex (800)
A00C hex	Insulation resistance failure critical	Sets the insulation resistance failure critical threshold. 0 to 9999 (Unit: 0.001 MΩ) (0000 to 270F hex)	2	R/W	0190 hex (400)
A00D to A012 hex	Reserved area	Reserved area	2	R/W	0000 hex
A013 hex	Transistor output method	Select transistor output method. 0: Normally Close 1: Normally Open	2	R/W	0000 hex
A014 hex	Monitoring delay time	Set the delay time from the trigger input to the start of measurement. 0.0 to 6000 (unit: 0.1 seconds) (0000 to 1770 hex)	2	R/W	0000 hex
A015 to A017 hex	Reserved area	Reserved area	2	R/W	0000 hex

*1. R: Read using Reading of multiple registers (03 hex).
W: Write using writing of multiple registers (10 hex).

9-3-3 Product Information

Address	Data name	Data Range	Number of bytes	R/W ^{*1}
C000 hex	Vendor ID	002F hex	2	R
C001 hex	Device type	0303 hex	2	R
C002 hex	Product code	*2	2	R
C003 hex	Device major revision	*3	2	R
C004 hex	Device minor revision	*3	2	R
C005 hex	Serial number	Product specific	4	R
C007 hex	MAC address	00 00 0A ** ** ** hex	4	R
C00A hex	Product name	*4	32	R

*1. R: Read using Reading of multiple registers (03 hex).

*2. Product code

Product code	Model
01FF hex	K6CM-CI2M□-EIP
01FC hex	K6CM-VBM□-EIP
01FD hex	K6CM-ISM□-EIP

*3. The device revision is as follows.

Example: In the case of version 1.23

Major: 0001 hex

Minor: 0023 hex

*4. Product name is in ASCII notation.

Example: 4B 36 43 4D...hex (K6CM...)

If the name is in less than 32 characters, all the succeeding areas become 00 hex.

9-3-4 IP Address

Address	Data name	Data Range	Number of bytes	R/W ^{*1}
C200 hex	IP address	Example: C0 A8 FA 0A hex (192.168.250.10)	4	R/W
C202 hex	Subnet mask	Default value: FF FF FF 00 hex (255.255.255.0)	4	R/W
C204 hex	The default gateway	Default value: 00 00 00 00 hex (0.0.0.0)	4	R/W
C206 hex	IP address setting method	0 hex: Fixed 1 hex: BOOTP 2 hex: BOOTP one-shot	4	R/W

*1. R: Read using Reading of multiple registers (03 hex).

W: Write using Writing of multiple registers (10 hex).

9-3-5 Operation Command

Address	Data name	Data Range	Number of bytes	R/W ^{*1}
D000 hex	Software reset	0001 hex: Execute	2	W
D001 hex	Max./min. reset	0001 hex: Execute	2	W

*1. W: Write using an operation command (06 hex).

9-3-6 Modbus TCP Connection Timeout Time

Address	Data name	Data Range	Number of bytes	R/W ^{*1}
F300 hex	Modbus TCP connection timeout time	0 to 3600, initial value = 10 (unit: second) (0: Timeout disabled)	2	R/W

*1. R: Read using Reading of multiple registers (03 hex).
W: Write using Writing of multiple registers (10 hex).

10

Trouble shooting

This section describes troubleshooting when using the K6CM devices.

10-1 K6CM Devices	10-2
10-2 Using the Software tool	10-4
10-3 Using the Ethernet communications	10-6

10-1 K6CM Devices

This section shows how to troubleshoot the K6CM devices.

If the K6CM device does not operate properly, check the items below as required before repair is requested. If it still does not work properly, return it through our sales department.

	Problems	Cause	Possible correction	Reference
Measurement values are not displayed.	7-segments display of measurement value are blinking.	The measurement value is over the input range.	Check the connected sensor.	1-3 <i>List of Models</i> on page 1-7
			Make sure that it is properly installed and wired	Section 5 Installation and Wiring
	"- - - -" is displayed.	In the case of a trigger (external trigger or internal trigger), "- - - -" is displayed until the trigger condition is satisfied (while monitoring is not yet done) after the power is turned ON.	Wait until the trigger condition is satisfied, or change the trigger mode at all times (without trigger).	3-2-4 <i>Trigger Mode</i> on page 3-5
			The sensor is not properly connected and installed.	<ul style="list-style-type: none"> When K6CM device is vibration & temperature type, confirm that the pre-amplifier is correctly connected. When K6CM device is Insulation resistance type, confirm that special ZCT is connected correctly. Also, confirm whether the specified voltage is input.
	"8 8 8 8" is blinking displayed.	The K6CM device may be damaged.	Contact our sales or distributor.	---
	MS indicator blinking red.	The sensor is not properly connected and installed.	<ul style="list-style-type: none"> When K6CM device is vibration & temperature type, confirm that the pre-amplifier is correctly connected. When K6CM device is Insulation resistance type, confirm that special ZCT is connected correctly. Also, confirm whether the specified voltage is input. 	Section 5 Installation and Wiring
One of the following conditions: Mes cpu error, Main CPU error, Present value input error, Maximum value input error, Minimum value input error			<ul style="list-style-type: none"> Turn ON the power of K6CM device again. If it still occurs, contact our sales or distributor.	---
The measurement value is displayed, but the MS flashes in red and the main CPU error in the Main body status is ON.	MS indicator is lit red.	The K6CM device or the sensor may be damaged.	Contact our sales or distributor.	---
		The hardware for running time function in the K6CM device may be faulty.	Contact our sales or distributor.	---
		Ambient temperature of the K6CM device exceeds the operating ambient temperature.	Use within the operating ambient temperature range.	---

Problems		Cause	Possible correction	Reference
The measurement value displayed is incorrect.	The measurement value is fixed and does not change.	In the case of a trigger (external trigger or internal trigger), the measurement value just before the end is held and displayed after monitoring is completed.	Turn ON the power again or change the trigger mode at all times (without trigger).	3-2-4 <i>Trigger Mode</i> on page 3-5
		(Insulation resistance type only) Even if the insulation resistance value exceeds 1 MΩ, 1 MΩ is displayed.	No problem.	A-1 <i>Specifications</i> on page A-2
	The measurement value is the higher limit or the lower limit value.	Sensor installation and wiring is incorrect.	Check the installation and wiring.	Section 5 <i>Installation and Wiring</i>
		(Comprehensive current diagnosis type only) The current cannot be measured correctly using a special CT.	<ul style="list-style-type: none"> Confirm the rating of CT and use the CT in the rating. Set the current range according to CT. 	A-1 <i>Specifications</i> on page A-2 6-2-2 <i>Setting Parameters</i> on page 6-23
		(Insulation resistance type only) The measured target circuit does not match the K6CM setting.	Correctly set the setting value of the Circuit topology, the Using inverter, and the Inverter special measurement.	6-2-2 <i>Setting Parameters</i> on page 6-23
Transistor output 1, 2	Transistor output 1 or 2 does not return during monitoring despite the measurement value that comprehensive alarm should be normal.	Alarm latch is set to "enable"	Press the [ALM RST] key on the front of the K6CM device to release the alarm latch. Alternatively, change the alarm latch to "disable (no latch)".	3-3-3 <i>Relationship Between Alarm and Display/Output</i> on page 3-14
	The transistor output does not match the state of the warning alarm and the critical alarm.	In the case of a trigger (external trigger or internal trigger), transistor outputs 1 and 2 are turned OFF even when monitoring is not performed after power is turned ON.	If the trigger condition is satisfied and the measurement is started, this condition will be resolved.	3-2-4 <i>Trigger Mode</i> on page 3-5
Transistor output 3	Transistor output 3 is OFF. Status display: "ERR"	<ul style="list-style-type: none"> Self diagnostic error is occurring. One of the following: Mes cpu error, measurement data flash Criticality, Main CPU error, main CPU data flash error, or input section error	<ul style="list-style-type: none"> Turn ON the power of K6CM device again. When K6CM device is vibration & temperature type, confirm that the pre-amplifier is correctly connected. When K6CM device is Insulation resistance type, confirm that special ZCT is connected correctly. If it still occurs, contact our sales or distributor.	---
An alarm appears when download setting information.		Attempted to set K6CM-CI2M in a software tool version earlier than 1.3.0.0.	Make the settings in a software tool version that is 1.3.0.0 or later.	A-7 <i>Setting Values</i> on page A-15

10-2 Using the Software tool

This section shows troubleshooting when using the software tool.

Problems	Cause	Possible correction	Reference
Monitoring is impossible with the K6CM from the software tool	The IP address of the computer is automatically acquired or fixedly set to a segment different from the IP address of the K6CM device.	Set the IP address of the computer to IP address of same segment as the K6CM device.	4-3 <i>IP Address Setting</i> on page 4-24
	The IP address setting of the K6CM on the project (It can be confirmed by [SYSMAC Gateway Console] Button) is different from the actual IP address	<ol style="list-style-type: none"> 1. Click [Delete Device] to delete the device that you registered erroneously. 2. Click Add device and add the device with the IP address that is actually connected. 	6-1-4 <i>Buttons on Device Setting</i> on page 6-13 6-2-3 <i>Add a Device to an Existing Project</i> on page 6-24
	The communications driver SYSMAC Gateway between the computer and the K6CM is stopped	<ol style="list-style-type: none"> 1. Click [Device setting] on the startup screen or click the [SYSMAC Gateway Console] Button on the monitoring screen to launch the SYSMAC Gateway Console screen. 2. Click the Start button in the Communications Service field. 	4-3-2 <i>IP Address Setting of the K6CM Devices</i> on page 4-26
	The network port setting of SYSMAC Gateway communications driver can not select the LAN card or IP address used for communications.	<ol style="list-style-type: none"> 1. Click [Device setting] on the startup screen or click the [SYSMAC Gateway Console] Button on the monitoring screen to launch the SYSMAC Gateway Console screen. 2. In the [Network Port] field, select the LAN card and IP address to use. 	4-3-2 <i>IP Address Setting of the K6CM Devices</i> on page 4-26
	Network port setting of SYSMAC Gateway communications driver, the IP address used for communications is AutoIP address (169.254.xxx.xxx).	Set the IP address of the network port setting of the SYSMAC Gateway communications driver to an IP address other than AutoIP.	4-3-2 <i>IP Address Setting of the K6CM Devices</i> on page 4-26
	[Start monitoring] Button is not clicked	Click the [Start monitoring] Button.	7-3-1 <i>Monitoring Procedure with Motor Condition Monitoring Tool</i> on page 7-9
The measurement value is displayed, but the value at a certain time is fixed and does not change	When using the trigger function (external trigger or internal trigger), the measurement value just before the end is held and displayed after monitoring is completed.	Measure the trigger condition and start measurement.	3-2-4 <i>Trigger Mode</i> on page 3-5
Accidentally forcing to end (e.g., turning off the PC power) during monitoring	----	<p>You can restore the logs from the backup until just before the forced termination.</p> <p>A confirmation message will be displayed asking if you want to use the backup data at the next project launch, so use it as necessary.</p>	----
The line graph is not displayed correctly.	<p>The software tool obtains the clock information from the PC.</p> <p>If the time information of the PC is incorrect, the dedicated tool records the measurement value with an incorrect date and time, so it cannot display the correct graph.</p>	Move the log file obtained with the wrong date and time to a different location and reopen the project file.	----

Problems	Cause	Possible correction	Reference
When you open the project file, "Failed to read the graph file." is displayed.	The log file is opened in another application.	Close the log file opened by another application and reopen the project file.	----
	The memory capacity of the PC is insufficient.	Move the log file to a different location and reopen the project file.	----
	The log file is damaged.	Move the suspected corruption log file to another location and reopen the project file.	----
The message "The available memory capacity becomes insufficient. The operation may be delayed." is displayed.	The memory capacity of the PC is insufficient.	Move the log file to a different location and reopen the project file.	----

10-3 Using the Ethernet communications

This section shows troubleshooting when using the EtherNet/IP.

● EtherNet/IP

Problems	Cause	Possible correction	Reference	
EtherNet/IP communications can not be executed when using BOOTP mode.	MS indicator blinking green.	IP address has not been acquired from the BOOTP server	Check the connection between BOOTP server and the K6CM devices. If you do not have a BOOTP server, press the [ALM RST] key and the [DISP] key at the same time for five seconds or more to initialize all settings of the K6CM device.	----
EtherNet/IP communications are not possible.	NS indicator is lit red.	The IP address of the built-in EtherNet/IP port is also used as the IP address of another node.	Change the IP address setting to avoid duplication.	
	NS indicator is not lit.	An Ethernet link OFF was detected.	Check the connection between the switching hub and the K6CM devices to see if the following items are normal. <ul style="list-style-type: none"> • Whether the Ethernet cable is broken, loose, or disconnected • Power state of the switching hub • Communications settings of the switching hub 	
A timeout occurred in a tag data link.	NS indicator blinking red.	Communications with the originator device timed out.	Make sure the following items are normal on the communications route. <ul style="list-style-type: none"> • Whether the Ethernet cable is broken, loose, or disconnected • Power supply state and operation state of the originator • Power state of switching hub • State of noise 	

● Modbus TCP

Problems	Cause	Possible correction	Reference	
Modbus TCP communications can not be executed when using BOOTP mode.	MS indicator blinking green.	IP address has not been acquired from the BOOTP server	Check the connection between BOOTP server and the K6CM devices. If you do not have a BOOTP server, press the [ALM RST] key and the [DISP] key at the same time for five seconds or more to initialize all settings of the K6CM device.	----



Appendices

A-1 Specifications	A-2
A-2 Measurement values by Each Monitor Type	A-3
A-3 K6CM Common Specifications	A-4
A-4 K6CM device Individual Specifications	A-8
A-5 Individual Specifications of the Dedicated Sensor	A-10
A-6 Internal Data of K6CM Devices	A-14
A-7 Setting Values	A-15
A-8 Present Values	A-21
A-9 Tag Data Link Connection Setting Procedures	A-26
A-9-1 Using the CS/CJ-series	A-26
A-9-2 Using the NJ/NX-series	A-38
A-10 Expansion Error Code of the CIP Message Communications	A-48
A-10-1 General Status	A-48
A-10-2 Additional Status When General Status Is 01 hex	A-50
A-11 Version Compatibility	A-51
A-11-1 Version Upgrades of the K6CM Series	A-51
A-11-2 Support Correspondence between the K6CM Device and Motor Condition Monitoring Tool	A-51
A-11-3 Motor Condition Monitoring Tool Version Compatibility	A-52
A-11-4 BOOTP Server Connection Error State LED Lighting Differences	A-52

A-1 Specifications

This section shows the common specifications and the individual specifications of the K6CM, and the specifications of the used sensors.

List of Models

● Comprehensive Current Diagnosis Type

	Model	Specifications such as power supply voltage
k6CM device	K6CM-CIMA-EIP	100 to 240 VAC
	K6CM-CIMD-EIP	24 V AC/DC
	K6CM-CI2MA-EIP	100 to 240 VAC
	K6CM-CI2MD-EIP	24 V AC/DC
Sensor (special CT)	K6CM-CICB005	Rated primary current: 5 A, rated voltage: 480 VAC
	K6CM-CICB025	Rated primary current: 25 A, rated voltage: 480 VAC
	K6CM-CICB100	Rated primary current: 100 A, rated voltage: 480 VAC
	K6CM-CICB200	Rated primary current: 200 A, rated voltage: 480 VAC
	K6CM-CICB400	Rated primary current: 400 A, rated voltage: 480 VAC
	K6CM-CICB600	Rated primary current: 600 A, rated voltage: 480 VAC

● Vibration & Temperature Type

	Model	Specifications such as power supply voltage
k6CM device	K6CM-VBMA-EIP	100 to 240 VAC
	K6CM-VBMD-EIP	24 V AC/DC
Sensor (sensor head and pre-amplifier)*1	K6CM-VBS1	Mounting: M6 screw

*1. The sensor head and the pre-amplifier are calibrated and inspected as a set at the factory shipment. Be sure to use them with the combination shipped.

● Insulation Resistance Type

	Model	Specifications such as power supply voltage
k6CM device	K6CM-ISMA-EIP	100 to 240 VAC
	K6CM-ISMD-EIP	24 V AC/DC
Sensor (special ZCT (IRT)) *1	K6CM-ISZBI52	Rated voltage: 200 to 480 VAC through hole diameter 52 mm

*1. ZCT (IRT) stands for Zero Current Transformer (Insulation Resistance Transformer).

A-2 Measurement values by Each Monitor Type

The measurement value, measurement range, and alarm monitoring of K6CM for each monitor type are shown in the following table.

Monitor type	Model	Measurement value	Measurement range	Alarm monitoring
Comprehensive current diagnosis type 2	K6CM-CI2	Degradation level 1 *1	0 to 999	Two levels of warning failure and critical failure are available for each measurement value.
		Degradation level 2 *1	0 to 999	
		Current	20 to 100% of each CT rating *2	
Vibration & temperature type	K6CM-VB	Acceleration*3	0.00 to 9.99 G	Two levels of warning failure and critical failure are available for each measurement value.
		Velocity *3	0.00 to 45.00 mm/s	
		Motor temperature	0 to 80°C	
		Temperature gap (i.e., difference between motor temperature and room temperature) *4	0 to 80°C	
Insulation resistance type	K6CM-IS	Insulation resistance *5	0.000 to 1.000 MΩ	Two levels of warning failure and critical failure are available for each measurement value.
		leakage current (i.e., I _{0r} , I _{0c}) *6	0.00 to 200.0 mA	Not available.

- *1. The lower the degradation level, the more normal the state of the motor. However, when the inverter is used, even if the motor is normal, the current waveform may be changed by the inverter. Therefore the deviation from the ideal sine wave may become large.
The recommended frequency range is 20 to 80 Hz when measuring the level of degradation. The degradation tendency of the motor appears less likely at frequencies higher than 80 Hz.
Even if within the range of recommended frequency, You may not be able to monitor the abnormality of the motor or load. Refer to *3-4-1 Comprehensive Current Diagnosis Type (K6CM-CI2)* on page 3-19 under *3-4 Guide for Setting Alarm* on page 3-19 for details.
- *2. One CT for detecting the current flowing in the motor must be used for each motor.
Use the following formula when you calculate the current value from the motor capacity.
$$\text{Current value of motor (A)} = \frac{\text{Motor capacity (kW)} \times 1000}{\text{Motor voltage (V)} \times \sqrt{3} \times \text{power factor (0.9)} \times \text{efficiency (0.8)}}$$
- *3. Measuring the magnitude of vibration of things are displacement, velocity, and acceleration. Displacement indicates how far it moved. The velocity shows how fast it moves, and the acceleration shows how fast it has reached that velocity. In the K6CM-VBM, velocity and acceleration can be measured.
- *4. The motor temperature is measured with the sensor head, and the room temperature is measured by the temperature sensor inside the pre-amplifier.
- *5. The insulation resistance type has a different measurement method from the insulation resistance meter (in particular, the voltage applied to the insulation resistance part and the measurement sensor). Therefore, depending on the measurement environment, the insulation resistance value measured with the insulation resistance type may be different from that with the insulation resistance meter.
- *6. The leakage current (I₀) can be classified into the following two types.
 - Capacitance leakage current (I_{0c}) generated through the capacitance between the noise filter or motor and the ground,
 - Resistance leakage current (I_{0r}) which causes electric shock and fire, caused by deterioration of wiring and the device,
 The K6CM-IS measures insulation resistance by separating and extracting I_{0r} from measured I₀. The relationship between I_{0c} and I_{0r} is shown below.

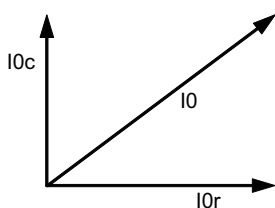

I₀: Leakage current
 I_{0r}: Leakage current component due to insulation resistance deterioration in I₀
 I_{0c}: Leakage current component due to ground capacitance in I₀

The K6CM-ISM monitors alarms according to the insulation resistance value. The measurement value of I_{0r} can also be confirmed, but alarm monitoring cannot be performed. (I_{0r} and insulation resistance are proportional. Therefore, alarm monitoring is based on insulation resistance.) There is no indication on the front of the K6CM device for I_{0c} (leakage current due to capacitance). It can be read by the software tool or by message communications.

A-3 K6CM Common Specifications

Function Specifications

Item		Specifications
Target motor		Three-phase induction motor *1 (possible for current on secondary side of inverter) However, depending on how the inverter is used, changes may not be confirmed by measurement. For the Insulation resistance type (K6CM-IS), refer to the <i>Wiring Diagram of the Insulation Resistance Type (K6CM-IS)</i> on page 5-27 in <i>5-6 I/O wiring</i> on page 5-25.
Input	Measurement value	It depends on the model of the K6CM device. Refer to "Measurement values for each K6CM device "
	Sampling cycle	It depends on measurement value. Refer to <i>A-4 K6CM device Individual Specifications</i> on page A-8
	Moving averaging of measurement values	Every time sampling is performed, it is possible to average past n times of data including that sampling data. Either n = 1, 2, 4, 8, 16, or 32 Moving averaging of measurement value
Trigger mode		Specify the start condition of monitoring. External trigger, internal trigger, or no trigger (always available) can be selected. Refer to <i>3-2 Measurement System</i> on page 3-3
Start and end of monitoring	In case of Free run (no trigger)	Monitoring during power ON
	In case of external trigger	One of the following <ul style="list-style-type: none"> • Start the monitoring when the external contact changes from OFF to ON, and end the monitoring when the monitoring time has elapsed. • Start the monitoring when the external contact changes from ON to OFF, and end the monitoring when the monitoring time has elapsed. • Monitoring while external input is ON
	In case of internal trigger	One of the following <ul style="list-style-type: none"> • Start the monitoring when the measurement value exceeds the set value (trigger level), and end the monitoring, when the monitoring time has elapsed. • Start the monitoring when the measurement value falls below the set value (trigger level), and end the monitoring, when the monitoring time has elapsed. • Monitoring while the set value (trigger level) is exceeded.
Number of Triggers		It is a function to simply estimate the life of the motor from the number of triggers since the start of measurement. The trigger count can not be reset. Total of external trigger and internal trigger: 0 to 6,553,500 times. The number of triggers is updated every hour. Therefore, if the power is turned OFF before 1 hour elapses, the trigger count can not be recorded correctly. When it reaches 6,553,500 times, it will not be counted any more.
Monitoring delay time		The monitoring delay is a function to delay the start of monitoring, and is used to wait for the measurement values to stabilize. The monitoring delay operates when the trigger mode is the external trigger or the internal trigger, and monitoring starts once the monitoring delay time has elapsed after the trigger start.
Alarm setting	By measurement value	It depends on K6CM device type. Refer to <i>6-2-1 Settings for Each Monitor Type of K6CM devices</i> on page 6-19. Critical level and Warning level can be set for each upper limit or lower limit (different depending on measurement value) of measurement value.
Alarm hysteresis		10% width of threshold setting value (fixed)
Alarm latch		Depending on the setting, you can specify None / Yes. If yes, the alarm condition (alarm bar, both transistor outputs 1 and 2) is latched. Can be released by the front [ALM RST] key (cancellation by communications is impossible).
Monitoring method	Individual alarm by measurement value	Compare the measurement value with the alarm set value (Critical level and Warning level) and output an alarm (Critical, Warning).
	Comprehensive alarm as K6CM device	When multiple alarms (Critical, Warning) occur, they are output by OR logic*2 with priority of Critical > Warning.

Item		Specifications
Output	Output form	Transistor output (normally closed)
	Functions	The following 3 outputs <ul style="list-style-type: none"> • Transistor output 1: Comprehensive alarm (Warning) output (Output type*3 can be set to Normally Open or Normally Close) • Transistor output 2: Comprehensive alarm (Critical) output (Output type *3 can be set to Normally Open or Normally Close) • Transistor output 3: Self diagnostic error output*4 (Normally Close fixed. Self-diagnosis error occurrence: OFF, self-diagnosis error not occurred: ON)
	Output rating	Contact configuration: NPN open collector Rated voltage: 24 VDC Maximum current: 50 mA
EtherNet/IP	Connected device	Software tool, or EtherNet/IP compatible equipment such as PC, PLC
	Communications type	<ul style="list-style-type: none"> • CIP message communication: reception of CIP command • Tag data link: Output only
Modbus TCP	Connected device	Modbus TCP compatible equipment such as PC, PLC
	Communications type	Message communication

- *1. Motors other than three-phase induction motors (e.g., synchronous motor, single phase motor, servo motor, stepping motor) are excluded.
- *2. Judgment of comprehensive alarm as a device:
 - Comprehensive alarm threshold setting (Warning) setting: A state in which "Critical" does not exist in the measurement value and "Warning" exists even in even one.
 - Threshold (Critical) setting for comprehensive alarm: A state in which at least one of the measurement values has "Critical".
- *3. Each transistor output 1 and 2 can not be set differently.
- *4. A self-diagnosis error occurs due to any one of the following reasons: Refer to *Section 10 Trouble shooting* when confirming self-diagnosis error.
 - Mes cpu error
 - Mes cpu data flash error
 - Main cpu error
 - Main cpu data flash error
 - Input unit error

Ratings

Item	Specifications
Power supply voltage	K6CM-□□MA: 100 to 240 VAC, 50/60 Hz (Alternating current) K6CM-□□MD: 24 VAC, 50/60 Hz, 24 VDC (Both direct and alternating current)
Allowable operating voltage range	85% to 110% of the rated power supply voltage
Power supply frequency range	45 to 65 Hz
Power consumption	K6CM-CI2 24 VAC/24 VDC: 3.2 VA/1.7W max. 100 to 240 VAC: 6.1 VA max. K6CM-VB 24 VAC/24 VDC: 3.8 VA/2.1W max. 100 to 240 VAC: 7.1 VA max. K6CM-IS 24 VAC/24 VDC: 3.7 VA/2.0W max. 100 to 240 VAC: 6.2 VA max.
Startup time at power ON	10 s or less Note : This is the time from power-ON until the monitoring start or "- - -" is displayed. After that, the measurement value is displayed after the sampling time has elapsed.
LCD display	7 segment digital display and single light display Character height 14 mm

Item	Specifications
Indicators	MS: red / green, NS: red / green, alarm bar: green / yellow / red
External trigger input	No-voltage contact and open collector are possible. Short circuit: Residual voltage 1.5 V or less Open: Leakage current 0.1 mA or less Short circuit current: approx. 7 mA Minimum trigger time: 0.1 s
Transistor output	Contact configuration: NPN open collector Rated voltage: 24 VDC (maximum voltage: DC 26.4 V) Maximum current: 50 mA Leakage current: 0.1 mA max. Residual voltage: 1.5 V max.
Ambient operating temperature	-10 to 55 °C (with no condensation or freezing)
humidity	25 to 85% (with no condensation)
Storage ambient temperature	-20 to 65 °C (with no condensation or freezing)
Storage humidity	25 to 85% (with no condensation)
Altitude	2,000 m max.
Recommended fuse (input)	UL R/C, CSA Component Acceptance, FIH250V2A, NIPPON SEISEN CABLE LTD
Insulation resistance	20 MΩ min. Between all external terminals and the case Between all power supply terminals and all other terminals Between all sensor connection terminals and trigger input terminal + output terminal + LAN port + all FG terminals
Dielectric strength	2,000 VAC for 1 minute Between all external terminals and the case Between all power supply terminals and all other terminals Between all sensor connection terminals and trigger input terminal + output terminal + LAN port + all FG terminals
Vibration resistance	Frequency: 10 to 55 Hz, 0.35-mm single amplitude, acceleration 50 m/s ² 10 sweeps of 5 min each in X,Y, and Z directions
Shock resistance	100 m/s ² , 3 times each in X, Y, and Z axes, 6 directions
Degree of protection	IP20
Warranty period	1 year
Terminal type	Push-In Plus
Exterior color	Black (Munsell N 1.5)
Applicable standards	Compliance standard: EN 61010-2-030 Installation environment: overvoltage category II, measurement category II (CAT II CT input, ZCT (IRT) input), pollution degree 2 (according to EN 61010-030) EMC: EN 61326 - 1 (EMI: Class A EMS: Industrial Location) Acceleration: ± 0.1 G, velocity: ± 2.25 mm/s, temperature: ± 6°C, insulation resistance: ± 35% rdg, current: ± 10% F. S. Safety standards: UL 61010-2-030 (Listing), Korean Radio Law, RCM
Mounting	DIN Rail mounting, or screw mounting
Weight	Approx. 200 g

Communications Specifications

● EtherNet/IP

Item		Specifications
Supported services		Tag data links (target), and CIP message communications (server) of the EtherNet/IP BOOTP client
Physical layer		100 BASE-TX
Transmission specifications	Baud rate	100 Mbps
	Transmission media	STP Category 5, or higher STP: Shielded twisted-pair cable
	Transmission distance	100 m max. (distance between hub and node)
Tag data links	Number of connections	1
	Packet interval (RPI)	250 ms to 10,000 ms
	Timeout value	RPI multiple (x 4, x 8, x 16, x 32, x 64, x 128, x 256, x 512)
	Data size	Input: 44 byte
	Connection Type	Point-to-point connection: (fixed)
Explicit message communications	Class 3	Number of connections that can communicate at one time: 2 max.
	UCMM	Number of clients that can communicate at one time: 2 max.

● Modbus TCP

Item		Specifications
Supported services		Modbus TCP (server)
Physical layer		100 BASE-TX
Transmission specifications	Baud rate	100 Mbps
	Transmission media	STP Category 5, or higher STP: Shielded twisted-pair cable
	Transmission distance	100 m max. (distance between hub and node)
Number of clients that can communicate at one time		2 max

● IP address (factory settings)

Item		Values
Factory setting value	IP Address	192 . 168 . 250 . 10
	Subnet mask	255 . 255 . 255 . 0
	Default gateway	0 . 0 . 0 . 0
	IP address setting method	Fixed IP address

A-4 K6CM device Individual Specifications

Models List

Model	Monitor type	Power supply voltage
K6CM-CI2MA-EIP	Comprehensive current diagnosis type 2	100 to 240 VAC
K6CM-CI2MD-EIP		24 VAC/VDC
K6CM-VBMA-EIP	Vibration & temperature type	100 to 240 VAC
K6CM-VBMD-EIP		24 VAC/VDC
K6CM-ISMA-EIP	Insulation resistance type	100 to 240 VAC
K6CM-ISMD-EIP		24 VAC/VDC

K6CM-CI2 Comprehensive Current Diagnosis Type 2

Item		Specifications	
Comprehensive current diagnosis	Rated input voltage	480 VAC (special CT)	
	Rated input current	5, 25, 100, 200, 400, and 600 A (primary current of the special CT)	
	Degradation level	Recommended frequency (*1)	20 to 80 Hz
		Display numerical unit	None (degradation level)
		Measurement range	0 to 999
		Resolution	1
		Sampling period	5 s
	Overcurrent	Rated frequency	20 to 80 Hz
		Display numerical unit	A
		Measurement range	1.00 to 5.00 A (at 5 A rating)
			5.0 to 25.0 A (at 25 A rating)
			20.0 to 100.0 A (at 100 A rating)
			40.0 to 200.0 A (at 200 A rating)
			80.0 to 400.0 A (at 400 A rating)
120.0 to 600.0 A (at 600 A rating)			
Resolution	0.01 A (at 5 A rated) 0.1 A (at 25, 100, 200 and 400 A rated) 0.2 A (at 600 A rated)		
Sampling period	5 s		
Accuracy	±0.5% FS ±1 digit (at 10 to 30 ° C, not including CT variation)		
Applicable motor type	Three-phase induction motor (Rated voltage: 480 V max.)		
Applicable motor capacities (*2)	1.5 to 300 kW (400 V)		
	0.75 to 150 kW (200 V)		

*1. The degradation tendency of the motor hardly appears when the inverter is used at frequencies higher than 80 Hz.

*2. Current value can be calculated from the motor capacity. Refer to A-5 Individual Specifications of the Dedicated Sensor on page A-10.

K6CM-VB Vibration & Temperature Type

Item		Specifications	
Vibration	Detection direction (*1)		Z direction (one axis)
	Acceleration	Detection frequency	1 to 10 kHz
		Measurement range	0.05 to 9.99 G
		Absolute accuracy	±3 dBrdg ±2 digit (at 25 °C) when using K6CM-VBS1
		Repeat accuracy	±0.2 dB
		Display numerical unit	G
		Display resolution	0.01 G
		Sampling Period	50 ms
	Velocity	Detection frequency	10 Hz to 1 kHz
		Measurement range	0.90 to 45.00 mm/s
		Display numerical unit	mm/s
		Display resolution	0.01 mm/s
Sampling Period		0.5 s	
Temperature	Allowable range (Motor surface)		-10 to +85°C
	Measurement range (Motor surface)		0 to 80°C (32 to 176°F)
	Ambient temperature range		-10 to +55°C
	Display numerical unit		°C, °F
	Display resolution		1°C (1°F)
	Absolute accuracy	Motor temperature	±3°C ± 2digit (±6°F±2digit) (*2)
		Temperature gap	±6°C ± 2digit (±12°F±2digit) (*2)
	Temperature gap		0.5 s
Applicable motor type		Three-phase induction motor (Rated voltage: 600 VAC max.)	
Applicable motor capacities		No limit	

*1. Refer to 5-2-3 *Installation of the Vibration & Temperature sensor* on page 5-7.

*2. Except when an adhesive attachment is used.

K6CM-IS Insulation Resistance Type

Item		Specifications	
Insulation resistance	Insulation resistance	Display numerical unit	MΩ
		Measurement range	0.000 to 1.000 MΩ
		Display resolution	0.001 MΩ
	Leak current (Both I0r and Ioc)	Display numerical unit	mA
		Measurement range	0.0 to 200.0 mA
		Display resolution	0.1 mA
	Accuracy		±35% rdg ± 2 digits (when insulation resistance is 0.2 MΩ or less), when using a motor of 200 V/7.5 kW or less ±35% rdg ± 2 digits (when insulation resistance is 0.4 MΩ or less), when using a motor of 400 V/7.5 kW or less
	Wiring length of power line to special ZCT (IRT) and motor		40m max.
	Sampling period		Normal mode: 10 s Inverter special measurement mode: 60 s
	Circuit topologys		1) Three-phase 3 wire, S-phase: ground 2) Three-phase four-wire, N-phase: grounding, load side: delta connection
	Line penetrable to special ZCT (IRT)		Power lines
	Rated input voltage		200 to 480 VAC (50/60 Hz)
	Operating Input Voltage		170 to 528 VAC (45 to 65 Hz)
	Applicable motor		Three-phase induction motor (Rated voltage: 480 V max.)
	Applicable motor capacities		0.75 to 7.5 kW

A-5 Individual Specifications of the Dedicated Sensor

Special Current Transformer (CT)

● Models

Model	Rated primary current	Rated secondary current	Connected K6CM device
K6CM-CICB005	5 A	Dedicated output	Comprehensive current diagnosis type (K6CM-CI2M)
K6CM-CICB050	25 A		
K6CM-CICB100	100 A		
K6CM-CICB200	200 A		
K6CM-CICB400	400 A		
K6CM-CICB600	600 A		

Note A special CT is provided with a connecting cable.

● Ratings and Specifications

Item	Model	K6CM -CICB005	K6CM -CICB025	K6CM -CICB100	K6CM -CICB200	K6CM -CICB400	K6CM -CICB600
Primary-side rated current		5 A	25 A	100 A	200 A	400 A	600A
Rated voltage		480 VAC					
Secondary winding		3000 turns				6000 turns	9000 turns
Insulation resistance		Between output terminal and case: 50 MΩ min.					
Dielectric strength		Between output terminal and case: 2,300 V, 1 min					
Protective element		7.5 V clamp element					
Permissible attachment/removal frequency		100 times					
Attachable wire diameter *1		7.9 mm dia. max.	9.5 mm dia. max.	14.5 mm dia. max.	24.0 mm dia. max.	35.5 mm dia. max.	
Operating temperature / humidity range		-20 to +60°C, 85% max. (with no condensation)					
Storage temperature / humidity range		-30 to +65°C, 85% max. (with no condensation)					
Provided cable length		2.9 m					
Terminal type for the provided cable		K6CM device side: Ferrule terminal CT side: Round terminal					

*1. When using a flat wire, be sure to refer to the external dimensions drawing of the CT before selection. Use a special CT with a larger diameter. However, use it within the range of rated current of CT.

The frequency characteristics of the CT are as follows.

K6CM-CICB005

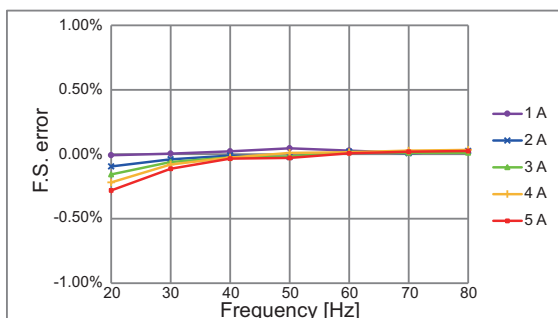

K6CM-CICB025

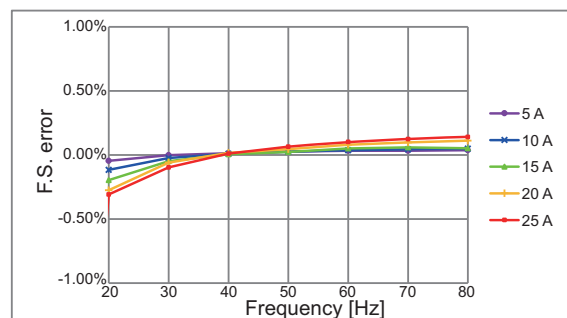

K6CM-CICB100

K6CM-CICB200

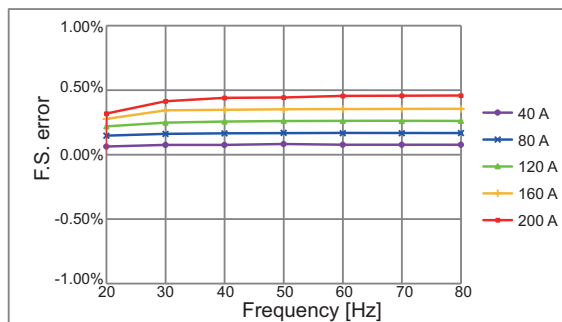
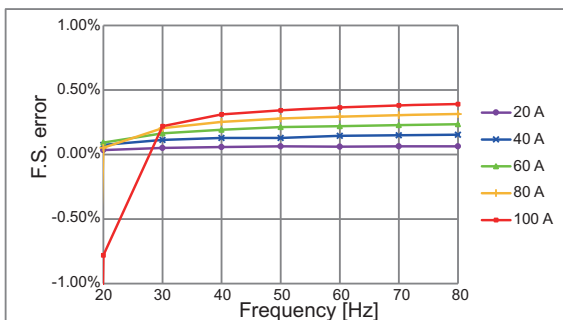

K6CM-CICB400

K6CM-CICB600

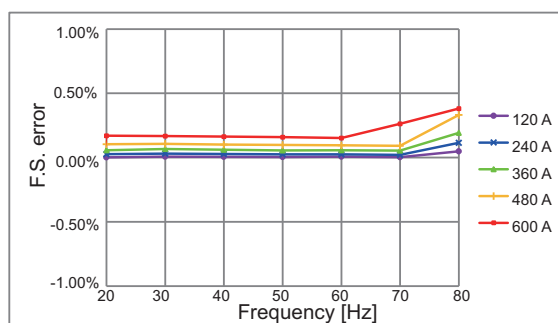
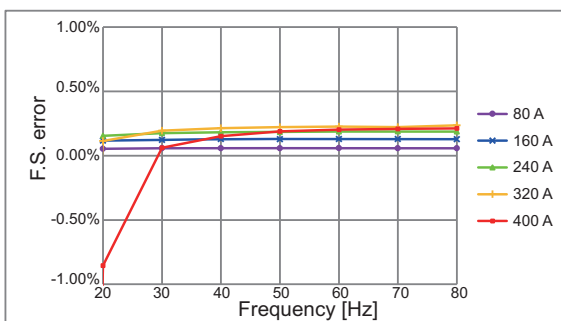

Vibration & Temperature Sensor

● Rating/Performance

Model	Screw diameter	Connected K6CM device
K6CM-VBS1	M6	Vibration & temperature type (K6CM-VBM)

Note Vibration and temperature sensor consists of sensor head and pre-amplifier. The K6CM-VBS1 is provided with a magnet for positioning of the vibration & temperature sensor.

● Rating/Performance

Power supply voltage		Supplied from K6CM-VBM (Direct current)
Sensor head	Max. acceleration	10 G
Ambient operating temperature		Pre-amplifier: -10 to +55°C (with no condensation or icing) Sensor head: -10 to +80°C (with no condensation or icing)
Storage temperature		Pre-amplifier: -20 to +65°C (with no condensation or icing) Sensor head: -20 to +90°C (with no condensation or icing)
Ambient operating humidity		25% to 85% RH (with no condensation)
Storage humidity		25% to 85% RH (with no condensation)
Altitude		2,000 m max.
Case color		Pre-amplifier: Black Sensor head: Silver
Case material		Pre-amplifier: PC UL94-V0 Sensor head: ADC12 and ZDC2 (the threaded part is S45C)
Weight		Pre-amplifier: Approx. 210 g (including cable) Sensor head: Approx. 40 g (including cable)
Mounting		Pre-amplifier: DIN rail mounting, Screw mounting Sensor head: Screw mounting Between pre-amplifier and sensor head: Connector connection
Wire length		Between pre-amplifier and sensor head: 2.9 m (cannot be extended) Between pre-amplifier and K6CM device: 1 m (can be extended up to a maximum length of 100 m)
Recommended cable between pre-amplifier and K6CM device		2464C BIOS-CL3-2402P-B (manufactured by Bando Densen Co., Ltd.)
Measurement range		Measurement range is described in the K6CM Individual Specifications.
Applicable standards	Conforming standards	EN61010-2-030 Installation environment: Pollution degree 2, overvoltage category II, measurement category II
	EMC	EN61326-1 (EMI: Class A EMS: Industrial Location)
	Safety standards	UL61010-2-030 (listing) Korean Radio Waves Act, RCM
Insulation resistance		20 MΩ min.
Dielectric strength		500 VAC for one minute
Vibration resistance	Pre-amplifier	Vibration frequency 10 to 55 Hz, slice amplitude 0.35 mm in each of X, Y, Z directions 5 minute × 10 sweeps
	Sensor head	Vibration frequency 10 to 55 Hz, slice amplitude 0.35 mm in each of X, Y, Z directions 5 minute × 10 sweeps
Shock resistance	Pre-amplifier	100 m/s ² , 3 times each in 6 directions along 3 axes
	Sensor head	100 m/s ² , 3 times each in 6 directions along 3 axes
Degree of protection	Pre-amplifier	IP20 (excluding the sensor-side cable)
	Sensor head	Conforming to IP67G
Indicators		Pre-amplifier PWR: Green, ERR: Red, COM: Yellow

Insulation Resistance Sensor (Special ZCT (IRT))

● List of Models

Model	Construction	Rated path current	Rated voltage	Through hole dia (mm)	Connected K6CM device
K6CM-ISZBI52	Split type	300 A	200 to 480 VAC	52 dia	Vibration & temperature type (K6CM-ISM)

Note A cable for connection is provided with the ZCT (IRT).

● Ratings and Specifications

Item	Model	K6CM-ISZBI52
Construction		Indoor split type
Rated current		300 A (When using the ground wire to penetrate)
Diameter of through holes		52 mm dia.
Circuit topology		Three-phase 3 wire, S-phase: ground Three-phase four-wire, N-phase: grounding, load side: delta connection
Power supply voltage		Supplied from K6CM-ISM , DC 10 V (Direct current)
Rated voltage:		200 to 480 VAC, 50/60 Hz, three-phase
Voltage input terminal		3-terminal lead wire L = 1 m
Output terminal		4-terminal lead wire L = 1 m
Cable length		Voltage input: 1 m (can be extended up to 100 m) Between ZCT (IRT) and K6CM device: 1 m (can be extended to 100 m)
Recommended cable		Voltage input: STO/TC(CE) # 18×3C (manufactured by Chugoku Electric Wire & Cable Co., Ltd.) Between ZCT(IRT) and K6CM device: 2464C-S-CL3-2402P-B (manufactured by Bando Densen Co., Ltd.)
Insulation resistance		Mounting bracket - Secondary winding: 100 MΩ min.
Dielectric strength		Mounting bracket - Secondary winding: 2.2 kV 1 min
Ambient operating temperature		-10 to 55°C (with no condensation or icing)
Storage temperature		-20 to 65°C (with no condensation or icing)
Ambient operating humidity		25 to 85% RH
Degree of protection		IP67 (IEC 60529)
Altitude		2,000 m max.
Applicable standards		Conforming standards: EN61010-2-030 Installation environment: Pollution degree 2, overvoltage category II, measurement category II EMC: EN61326-1 (EMI: Class A EMS: Industrial Location) Safety standards: UL61010-2-030 (Recognition) + CSA C22.2 No. 61010-2-030 Korean Radio Waves Act, RCM
Adaptive fuse		1 A, 480 V, UL Listed, CSA Certified
Installation environment		Overvoltage category II, Measurement category II (CAT II, ZCT (IRT) input), Pollution Degree 2 (EN 61010-1)
Weight		Approx. 2.3 kg (including cables)

A-6 Internal Data of K6CM Devices

This section describes the overview of the internal data of the K6CM devices.

The K6CM device has setting values and present values (i.e., measurement value and alarm results) as internal data.

You can write or read these setting values and present values (PV) in the following way.

Method	Internal data of K6CM		Reference
	Setting value	Present value	
Motor condition monitoring Tool (Software tool)	Writable, readable (Note. depending on the item)	Readable (Note. depending on the item)	<i>Section 6 How to Use the Motor condition monitoring Tool</i> <i>7-3 Motor Monitoring Using Software Tools on page 7-9</i>
CIP message communications	Writable, readable	Readable	<i>8-3 Monitoring and Setting Using the CIP Message Communications Instructions on page 8-12</i>
Tag data link	Can not write	Readable	<i>8-2 Monitoring Using the Tag Data Link on page 8-5</i>
Modbus TCP message communications	Writable, readable	Readable	<i>Section 9 Monitoring and Setting Using the Modbus TCP Devices</i>

For details of internal data, refer to *A-7 Setting Values* on page A-15 and *A-8 Present Values* on page A-21 below.

A-7 Setting Values

In this section, the setting values in the internal data of the K6CM devices are classified according to K6CM common and monitor type, and are shown in a list.



Precautions for Correct Use

In order to validate the setting value, it is necessary to turn the power supply ON again or perform a software reset after changing the set value.

The alarm threshold settings are performed by integer values (e.g., 0 to 9999) regardless of the measurement range. Therefore, confirm the measurement range and units in the table shown below, and then set the alarm threshold.

● Alarm Setting Values (threshold value)

Comprehensive Current Diagnosis Type 2 (K6CM-CI2M)

Data name	Description	Writing method (Yes: supported, No: supported)			
		Software tool	CIP message communications / Modbus TCP message communications	Tag data link	Remarks
Degradation level 1 or 2, Upper limit critical and warning threshold	0 to 9999 *1	Yes	Yes	No	
Current, Upper limit critical and warning threshold	0 to 9999 Unit: Current range = 0: 0.01 A Current range = 1 to 5: 0.1 A	Yes	Yes	No	

*1. When this is set with Motor condition monitoring Tool of a version earlier than 1.2.0.0, an alarm is generated because the degradation level 2 threshold value is set as 0. When using K6CM-CI2M, use a supported tool version. Degradation level 2 is not supported by K6CM-CIM.

Vibration & temperature Type (K6CM-VBM)

Data name	Description	Writing method (Yes: supported, No: supported)			
		Software tool	CIP message communications / Modbus TCP message communications	Tag data link	Remarks
Acceleration, Upper limit critical and warning threshold	0 to 9999 (unit: 0.01 G)	Yes	Yes	No	
Velocity, Upper limit critical and warning threshold	0 to 9999 (unit: 0.01 mm/s)	Yes	Yes	No	
Motor temperature, Upper limit critical and warning threshold	0 to 9999 (unit: °C)	Yes	Yes	No	
Temperature gap, Upper limit critical and warning threshold	0 to 9999 (unit: °C)	Yes	Yes	No	

Insulation Resistance Type (K6CM-ISM)

Data name	Description	Writing method (Yes: supported, No: supported)			
		Software tool	CIP message communications / Modbus TCP message communications	Tag data link	Remarks
Insulation resistance, Lower limit critical and warning threshold	0 to 9999 (Unit: 0.001 MΩ)	Yes	Yes	No	

● Other Setting Values

Common to the K6CM Devices

Data name	Description	Writing method (Yes: supported, No: supported)			
		Software tool	CIP message communications / Modbus TCP message communications	Tag data link	Remarks
K6CM IP address	Sets the IP address of the K6CM. The initial value is "192.168.250.10" (common to models)	Yes	Yes	No	
Software reset	Restarts the K6CM device. It is used to validate the setting after changing the setting value. Rising from 0 to 1: Execute (software reset)	Yes (Software reset button)	Yes	No	
Max./min. reset	Initializes the Max./min. value. OFF to ON: Execute (initialize max. and min. value)	Yes (Reset the Max./min. value button)	Yes	No	
Display value type	Sets which measurement value is displayed in the 7 segment display of the K6CM. 0: PV 1: MIN 2: MAX To see which measurement value is displayed, you can check with the monitoring category display on the K6CM. "PV": present value, "MIN": minimum value, "MAX": maximum value	Yes	Yes	No	
Trigger mode	Selects either internal trigger, external trigger, free run (no trigger). 0: Free run 1: External trigger 2: Internal trigger	Yes	Yes	No	
Trigger type	For internal trigger or external trigger, select either rising, falling, or level. 0: Rising 1: Falling edge 2: Level • For internal trigger: Rise: When the measurement value exceeds the set value (trigger level) Falling edge: When the measurement value falls below the set value (trigger level) Level: During the measurement value exceeds the setting value (*1) • For external trigger: Rise: When external input changes from OFF to ON Falling edge: When external input changes from ON to OFF Level: External input is in the ON state	Yes	Yes	No	

*1. In the case of "Insulation resistance" for the lower limit alarm, it oppositely means "lower" than the setting value.

Data name	Description	Writing method (Yes: supported, No: supported)			
		Software tool	CIP message communications / Modbus TCP message communications	Tag data link	Remarks
Trigger level	<p>Sets the trigger level when the trigger mode is "internal trigger". Set value: Set in each measurement range.</p> <p>Note : Unit and decimal point position follow measurement values. For each K6CM, set the trigger level for the following monitoring category.</p> <ul style="list-style-type: none"> • Comprehensive current diagnosis type: current • Vibration & temperature type: Acceleration • Insulation resistance type: Insulation resistance 	Yes	Yes	No	
Monitoring time	<p>In the case of an internal trigger or an external trigger, set the time to continue monitoring when the trigger type rises or falls. Setting value: 0.1 to 600.0 seconds. It is common in case of internal trigger and external trigger.</p>	Yes	Yes	No	
Alarm latch	<p>Sets enable /disable of alarm latch function. 0: Disable (no latch) 1: Enable (with latch)</p>	Yes	Yes	No	
Use Running Time	<p>Sets the usage or nonuse of K6CM remaining capacity function. 0: OFF (not used) 1: ON (use)</p>	Yes	Yes	No	
Moving average times	<p>Every time the measurement value is sampled, the data of the past n times including the sampling data of that time is averaged. 0: OFF 1: 2 times 2: 4 times 3: 8 times 4: 16 times 5: 32 times</p>	Yes	Yes	No	
Transistor output method	<p>Select transistor output method. 0: Normally Close 1: Normally Open</p>	Yes	Yes	No	Supported in Eip cpu version 1.1 (CIP Revision 2) or later
Monitoring delay time	<p>Set the delay time from the trigger input to the start of measurement. Set value: 0.0 to 600.0 seconds.</p>	Yes	Yes	No	Supported in Eip cpu version 1.2 (CIP Revision 3) or later

Comprehensive Current Diagnosis Type 2 (K6CM-CI2M)

Data name	Description	Writing method (Yes: supported, No: supported)			
		Software tool	CIP message communications / Modbus TCP message communications	Tag data link	Remarks
Current range	Sets the current range. 0: 5 A 1: 25 A 2: 100 A 3: 200 A 4: 400 A 5: 600 A	Yes	Yes	No	
Current moving average times	Set the current moving average times. 0: OFF 1: 2 times 2: 4 times 3: 8 times 4: 16 times 5: 32 times	Yes	Yes	No	Supported in Eip cpu version 1.2 (CIP Revision 3) or later
Degradation level 1 moving average times	Set the degradation level 1 moving average times. 0: OFF 1: 2 times 2: 4 times 3: 8 times 4: 16 times 5: 32 times	Yes	Yes	No	Supported in Eip cpu version 1.2 (CIP Revision 3) or later
Degradation level 2 moving average times	Set the degradation level 2 moving average times. 0: OFF 1: 2 times 2: 4 times 3: 8 times 4: 16 times 5: 32 times	Yes	Yes	No	Supported in Eip cpu version 1.2 (CIP Revision 3) or later

Note When the previous moving average times is set, it is also set for the degradation level 1 moving average times and current moving average times.

Vibration & temperature Type (K6CM-VBM)

Data name	Description	Writing method (Yes: supported, No: supported)			
		Software tool	CIP message communications / Modbus TCP message communications	Tag data link	Remarks
Temperature unit	Sets the temperature unit. 0: °C 1: °F	Yes	Yes	No	

Note If you change from "°C" to "°F", a temperature alarm may be generated depending on the setting of the alarm setpoint. When you have changed the setting of the temperature unit, also change the alarm setpoints of the motor temperature and temperature gap to the set value according to the temperature unit.

Insulation Resistance Type (K6CM-ISM)

Data name	Description	Writing method (Yes: supported, No: supported)			
		Software tool	CIP message communications / Modbus TCP message communications	Tag data link	Remarks
Circuit topology	Sets the Circuit topology. 0: Three-phase three-wire system, S-phase grounding 1: Three-phase four-wire system, N-phase grounding, delta connection load	Yes	Yes	No	
Using inverter	Sets the presence or absence of the inverter. 0: OFF (No inverter) 1: ON (with inverter) (For 3 phase 4 wires N phase ground load side delta connection, use with no inverter. If you have an inverter you can not do the correct measurement.)	Yes	Yes	Nos	
Inverter special measurement	Sets the Inverter Special measurement. 0: OFF 1: ON Special calculation to do when inverter frequency and commercial frequency are close. For how to use this function, refer to the <i>Wiring Diagram of the Insulation Resistance Type (K6CM-IS)</i> on page 5-27 in <i>5-6 I/O wiring</i> on page 5-25. Note : With or without inverter = "with inverter" only valid	Yes	Yes	No	

A-8 Present Values

In this section, the present values in the internal data of the K6CM devices are classified according to K6CM common and monitor type, and are shown in a list.

- Measurement Value

Comprehensive Current Diagnosis Type 2 (K6CM-CI2M)

Data name	Description	Reading method (Yes: supported, No: supported)				
		K6CM device	Software tool	CIP message communications / Modbus TCP message communications	Tag data link	Remarks
Degradation level 1 / Degradation level 2 (Present, MIN., MAX.)*1	Degradation level of motor calculated by measuring current including harmonic components. Indicator of comprehensive current diagnosis. 0 to 999 (K6CM display)	Yes	Yes	Yes	Yes	
Current (Present, Min., Max.)	Current range = 0: 0.00 to 5.00 A Current range = 1: 0.0 to 25.0 A Current range = 2: 0.0 to 100.0 A Current range = 3: 0.0 to 200.0 A Current range = 4: 0.0 to 400.0 A Current range = 5: 0.0 to 600.0 A	Yes	Yes	Yes	Yes	
Degradation level 1 / Degradation level 2 status*1	Bit00: Present value unmeasured state Bit01: Present value input error Bit04: Maximum value unmeasured state Bit05: MAX value input error	No	Yes	Yes	Yes	
Current status	Bit08: Minimum value unmeasured state Bit09: MIN value input error Bit12: Individual alarm result (Warning) Bit13: Individual alarm result (Critical)	No	Yes	Yes	Yes	

*1. Degradation level 2 is not supported by K6CM-CIM.

Vibration & temperature Type (K6CM-VBM)

Data name	Description	Reading method (Yes: supported, No: supported)				
		K6CM device	Software tool	CIP message communications / Modbus TCP message communications	Tag data link	Remarks
Acceleration (PV, Min., Max.)	0.00 to 9.99 G (K6CM display)	Yes	Yes	Yes	Yes	
Velocity (PV, Min., Max.)	0.00 to 45.00 mm/s (K6CM display)	Yes	Yes	Yes	Yes	
Motor temperature (PV, Min., Max.)	0 to 80°C (32 to 176°F) (K6CM display)	Yes	Yes	Yes	Yes	
Temperature gap (Difference from the room temperature of Motor temperature)(PV, Min., Max.)	0 to 80°C (32 to 176°F) (K6CM display)	Yes	Yes	Yes	Yes	
Acceleration status	Bit00: Present value unmeasured state Bit01: Present value input error	No	Yes	Yes	Yes	
Velocity status	Bit04: Maximum value unmeasured state	No	Yes	Yes	Yes	
Motor temperature status	Bit05: Maximum value input error Bit08: Minimum value unmeasured state	No	Yes	Yes	Yes	
Temperature gap status	Bit09: Minimum value input error Bit12: Individual alarm result (Warning) Bit13: Individual alarm result (Critical)	No	Yes	Yes	Yes	

Insulation Resistance Type (K6CM-ISM)

Data name	Description	Reading method (Yes: supported, No: supported)				
		K6CM device	Software tool	CIP message communications / Modbus TCP message communications	Tag data link	Remarks
Insulation resistance (Present, Min., Max.)	0.000 to 1.000 MΩ (K6CM display)	Yes	Yes	Yes	Yes	
Leakage current I _{0r} (Present, Min., Max.)	0.0 to 200.0 mA (K6CM display)	Yes	Yes	Yes	Yes	
Leakage current-loc (Present)	0.0 to 200.0 mA (communications)	No	Yes	Yes	Yes	
Insulation resistance status	Bit00: Present value unmeasured state Bit01: Present value input error Bit04: Maximum value unmeasured state Bit05: Maximum value input error Bit08: Minimum value unmeasured state Bit09: Minimum value input error Bit12: Individual alarm result (Warning) Bit13: Individual alarm result (Critical)	No	Yes	Yes	Yes	

Common to the K6CM Devices

Data name	Description	Reading method (Yes: supported, No: supported)				
		K6CM device	Software tool	CIP message communications / Modbus TCP message communications	Tag data link	Remarks
Mes cpu version	Measurement part version	No	Yes	Yes	Yes	
Main cpu version	Main part version	No	Yes	Yes	Yes	
Eip cpu version	EtherNet/IP version	No	Yes	Yes	Yes	
Main body status	During monitoring, transistor output 1, 2, 3 state, external trigger input state, etc. It consists of the following contents.	No	Yes	Yes	Yes	
Monitoring condition	The state measured and monitored by K6CM. "MON" on the LCD display lights up. In the case of an internal trigger or an external trigger, it is monitored by a trigger. In case that the Trigger Mode is "Free run (no trigger)", it is always monitored with power ON. 1: Monitoring 0: Monitoring stopped	Yes ("MON")	Yes	Yes (part of Main body status)	Yes (part of Main body status)	
Running Time status	Turns ON when running time reaches 100%. Accumulates the product of operation time and internal temperature, and detects abnormality when design life reaches. 1: Reached (running time reaches 100%) 0: Not reached (running time has not reached 100%)	Yes (according to "AGE" indication)	Yes	Yes (part of Main body status)	Yes (part of Main body status)	
Trigger input	State of external trigger input 1: ON 0: OFF	No	Yes	Yes (part of Main body status)	Yes (part of Main body status)	
Tr1 (transistor 1 output state)	State of transistor 1 of K6CM 1: ON 0: OFF	No	Yes	Yes (part of Main body status)	Yes (part of Main body status)	
Tr2 (transistor 2 output state)	State of transistor 2 of K6CM 1: ON 0: OFF	No	Yes	Yes (part of Main body status)	Yes (part of Main body status)	
Tr3 (transistor 3 output state)	State of transistor 3 of K6CM 1: ON 0: OFF	No	Yes	Yes (part of Main body status)	Yes (part of Main body status)	
Running Time	Coefficient indicating lifetime of the K6CM device based on the product of operation time and internal temperature. It increases from 0% in 10% increments. 0000 to 0064 hex (0 to 100)	No	Yes	Yes	Yes	
Number of triggers	Total number of integration times of external trigger or internal trigger. Make +1 every 100 iterations. 0 to 65535	No	Yes	Yes	Yes	

A

● Alarm Results

Common to the K6CM Devices

Data name	Description	Reading method (Yes: supported, No: supported)				
		K6CM device	Software tool	CIP message communications / Modbus TCP message communications	Tag data link	Remarks
Comprehensive alarm (Warning)	In K6CM, there is no "Critical" in the measurement value, and even one of them has "Warning". Transistor output, alarm bar (yellow) is reflected	Yes (Alarm bar, and transistor output)	Yes	Yes (Main body status)	Yes (Main body status)	
Comprehensive alarm (Critical)	Within K6CM, there is "Critical" even if at least one measurement value. Transistor output, reflected on alarm bar (red)	Yes (Alarm bar, and transistor output)	Yes	Yes (Main body status)	Yes (Main body status)	

Comprehensive Current Diagnosis Type 2 (K6CM-CI2M)

Data name	Description	Reading method (Yes: supported, No: supported)				
		K6CM device	Software tool	CIP message communications / Modbus TCP message communications	Tag data link	Remarks
Degradation level 1, Degradation level 2, High alarm (Critical and Warning) *1	ON, OFF	No	Yes	Yes	Yes	
Current, High alarm (Critical and Warning)	ON, OFF	No	Yes	Yes	Yes	

*1. Degradation level 2 is not supported by K6CM-CIM.

Vibration & temperature Type (K6CM-VBM)

Data name	Description	Reading method (Yes: supported, No: supported)				
		K6CM device	Software tool	CIP message communications / Modbus TCP message communications	Tag data link	Remarks
Acceleration, High alarm (Critical and Warning)	ON, OFF	No	Yes	Yes	Yes	
Velocity, High alarm (Critical and Warning)	ON, OFF	No	Yes	Yes	Yes	
Motor temperature, High alarm (Critical and Warning)	ON, OFF	No	Yes	Yes	Yes	
Temperaturegap, High alarm (Critical and Warning)	ON, OFF	No	Yes	Yes	Yes	

Insulation Resistance Type (K6CM-ISM)

Data name	Description	Reading method (Yes: supported, No: supported)				
		K6CM device	Software tool	CIP message communications / Modbus TCP message communications	Tag data link	Remarks
Insulation resistance, Low alarm (Critical and Warning)	ON, OFF	No	Yes	Yes	Yes	

A-9 Tag Data Link Connection Setting Procedures

A-9-1 Using the CS/CJ-series

You can set tag data link settings using the Network Configurator for EtherNet/IP.

When using the CS/CJ-series PLC as an originator, use the Network Configurator for EtherNet/IP supporting the model and version of the CPU Unit. Refer to the CS/CJ Series EtherNet/IP Units Operation Manual (Cat. No.W465) for the setting status of the setting tool.

The setting method when the CS/CJ-series PLC is an originator is as follows.

1 Starting the Network Configurator for EtherNet/IP

To start the Network configurator, select [All Programs] | [OMRON] | [Sysmac Studio] | [Network Configurator for EtherNetIP] | [Network Configurator] from the Windows Start Menu.

The Main Window consists of a Hardware List and a Network Configuration Pane, as shown in the following diagram.

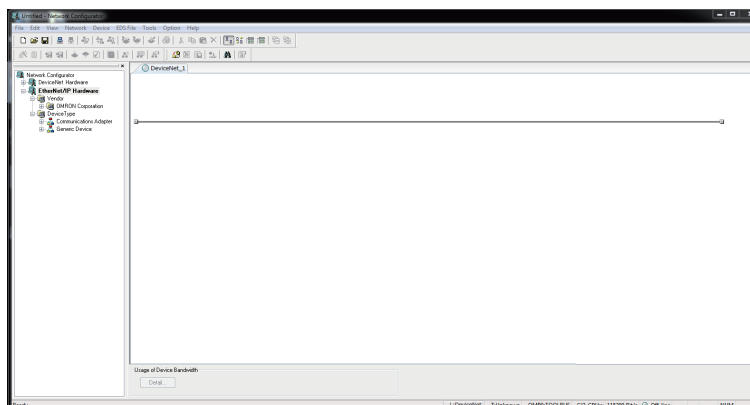

2 Starting the EtherNet/IP network setting screen

Select [File] | [Create New (N)] | [EtherNet/IP] from the menu bar.

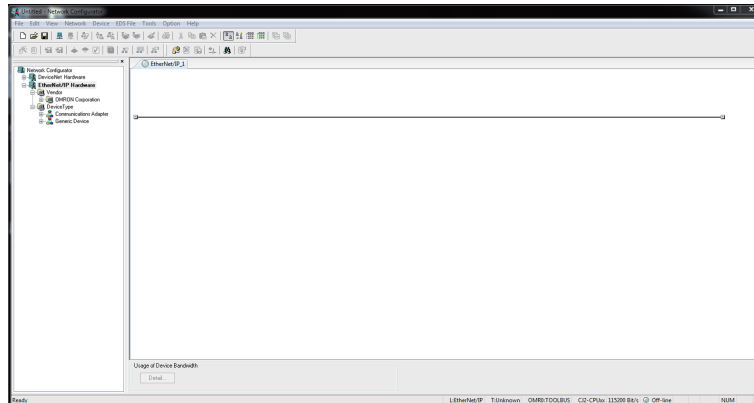

3 Installing EDS Files

To configure K6CM as an EtherNet/IP tag data link communications target, install the EDS file containing the configuration information of the K6CM in the Network Configurator. Once this installation is done, this operation is unnecessary from the next setting.

This operation is unnecessary with Network Configurator Ver.3.69a or later because the file comes pre-installed.

If you are using an earlier version, install using the EDS file which is stored on the CD bundled with the K6CM device. EDS files can also be downloaded from our I-Web.

Register the CIP revision corresponding to the EIP version on the side label of the K6CM device.

EIP version	CIP revision	
	Major revision	Revision on the Hardware list
Ver.1.0	1	Rev1
Ver.1.1	2	Rev2
Ver.1.2	3	Rev3

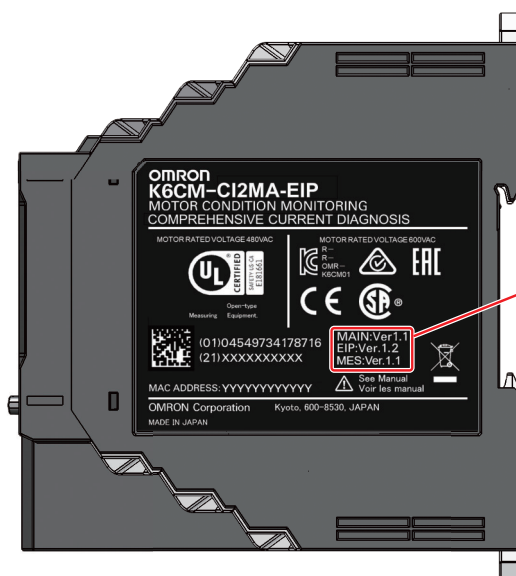

MAIN: Main cpu version

EIP: Eip cpu version

MES: Mes cpu version

Select [EDS File] | [Install (I) ...] on the menu bar.

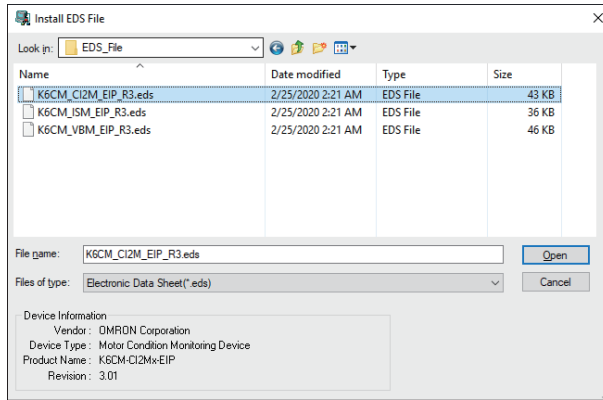

After selecting the following EDS file, click [Open] and install it.

Model name of the K6CM	EDS file name
K6CM-CI2M	K6CM_CI2M_EIP_R3.eds
K6CM-VBM	K6CM_VBM_EIP_R3.eds
K6CM-ISM	K6CM_ISM_EIP_R3.eds

At this time, an icon confirmation message will be displayed. Click [Yes].

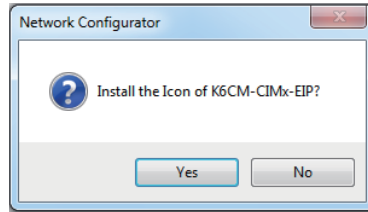

After selecting the following ICON file, click [Open] and install it.

Model name of the K6CM	ICON file name
K6CM-CI2M	128x128.ico
K6CM-VBM	
K6CM-ISM	

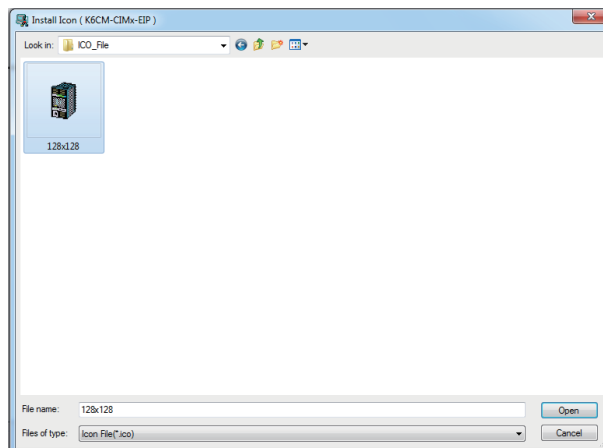

When the installation is completed, the device is added to the hardware list.

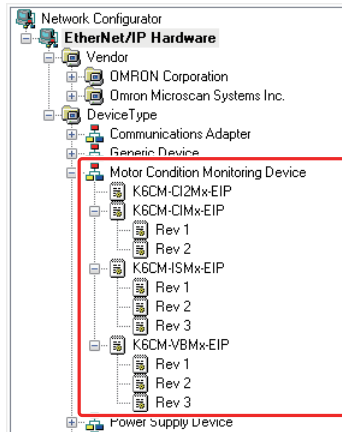

4 Registering devices

(1) Device registration to the network configuration

Register the EtherNet/IP devices which participate in the tag data links in the Network Configuration Window.

From the hardware list, you can register a PLC as an originator device and K6CM devices, by dragging and dropping each device at a time, or by selecting and double-clicking it.

As an example, register a CJ1W-EIP21 (Rev 3) in the "Communications Adapter" category as an originator device and register a K6CM-CI2M as a target device.

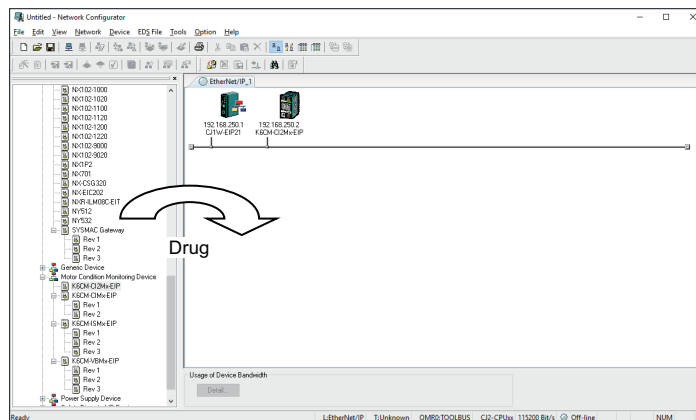

Note Select the same model as the device you use and register it.

The device names and major CIP revisions (Rev □) are displayed in the hardware list.
 The device name and the major CIP revision of the CS/CJ-series CPU Unit are as follows.

Device name in hardware list	Unit version	CIP revision	
		Major revision	Revision name in hardware list
CJ2B-EIP21	Unit version.2.0 and 2.1	2	Rev2
	Unit version.3.0	3	Rev3
CJ2M-EIP21	Unit version.2.0 and 2.1	2	None
CJ1W-EIP21	Unit version.1.0	1	Rev1
	Unit version.2.0 and 2.1	2	Rev2
	Unit version.3.0	3	Rev3
CS1W-EIP21	Unit version.1.0	1	Rev1
	Unit version.2.0 and 2.1	2	Rev2
	Unit version.3.0	3	Rev3
CJ1W-EIP21 (CJ2)*1	Unit version.2.0 and 2.1	2	Rev2
	Unit version.3.0	3	Rev3

*1.This shows the case where the CJ1W-EIP21 Unit is mounted on the CJ2 CPU Unit.

(2) Device Node Address (IP Address) Setting

Set the node address (IP address) of the device to be used.

In the Network Configuration Window, click the device you want to change the node address (IP address), right click and select [Change Node Address...].

Enter the node address (IP address) of the device to be used actually, and click [OK].

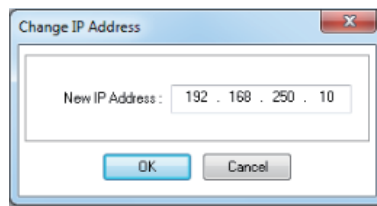

5 EtherNet/IP Connection Settings

(1) Create Tag sets and Tags

Create tag sets and those members tags necessary for connection for the registered EtherNet/IP Unit. For tags, you can set the I/O memory address or network symbols used by the control program (CJ2H-CPU6□-EIP21 and CJ2M-CPU3□ only).



Additional Information

The setting contents depend on the originator device connecting the K6CM series.

For detailed settings, refer to the manual of the originator device.

- "SYSMAC CS/CJ Series EtherNet/IP Units Operation Manual (Cat. No.W465)"



Additional Information

Tag set names and tag names can also be created in advance using the CX-Programmer. When creating in advance, make them the same names as the tags to be created with the NetworkConfigurator. You can also use them as symbol variables of PLC by sharing them with CX-Programmer by importing from or exporting to a file the tag set names and tag names of PLC edited with Network Configurator.

For detailed settings, refer to the manual of the originator.

(1)-1 Tag Editing

Select the device (e.g., CJ1W-EIP21) for editing the tag set and the tag.

Then right-click it and select [Parameter (P)] | [Edit (E) ...] or double-click it.

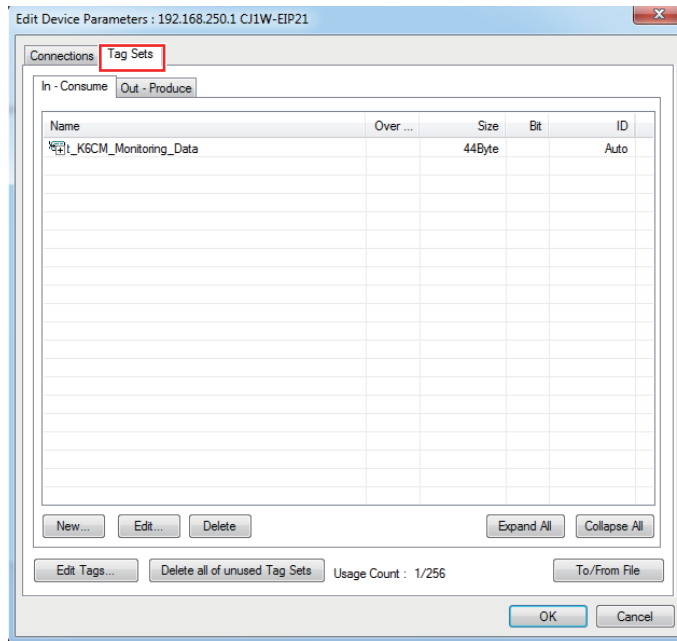

Click the Tag Sets Tab at in the Edit Device Parameters Dialog Box.

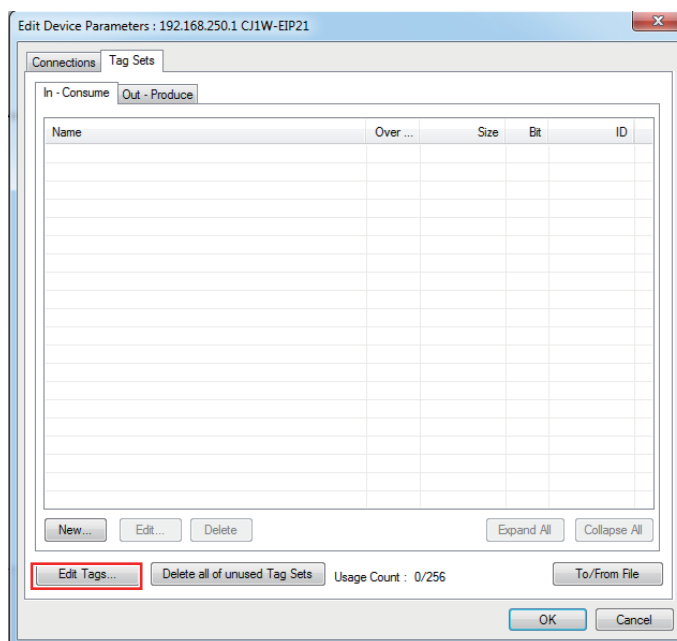



Additional Information

If you have created network symbols, tag set names and tag names in advance with the CX-Programmer and have the exported file (.CSV), click [To/From File] at the lower right, select [Import from File...]. By doing so, you can omit the following "(1) -1 Tag editing" and "(1) -2 Editing tag set" below.

Click [Edit Tag (T) ...] in the Edit Device Parameters Dialog Box to edit tag sets.

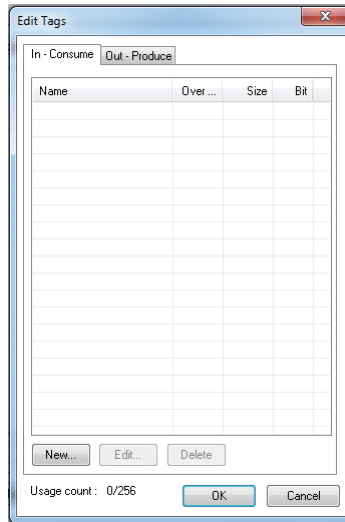

To enter tags, there are tabs for Input (Consume) and Output (Produce), but set only the Input (Consume) tab when connecting the K6CM series. Select the [In - Consume] Tab and click [New (N) ...], the Edit Tags Dialog Box will be displayed.

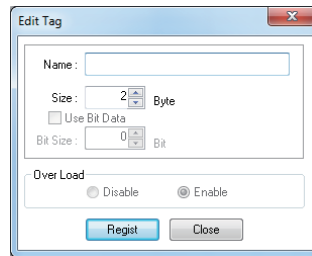

Enter the tag name and its size (44 bytes), and click [Register (R)].

As a "tag name", enter the character string for the CPU Unit's I/O memory address or a network symbol (e.g., 100, W100, D0, Input_signal).

Addresses in the following I/O memory areas can be set.

CPU Unit's data area		Address (Text to input in Name Field.)
CIO Area		0000~6143
Holding Area		H000~H511
Work Area		W000~W511
DM Area		D00000~D32767
EM Area	Bank 0 hex	E0_00000~E0_32767

	Bank 18 hex	E18_00000~E18_32767



Additional Information

Here, create a symbol that matches the name of the I/O memory address used in the PLC or the name of the network symbol (input).

(1)-2 Editing tag set

To enter tags, there are tabs for Input (Consume) and Output (Produce), but set only the Input (Consume) tab when connecting the K6CM series.

For editing tag set, click [New (N) ...] in the following Edit Tag Set Dialog Box.

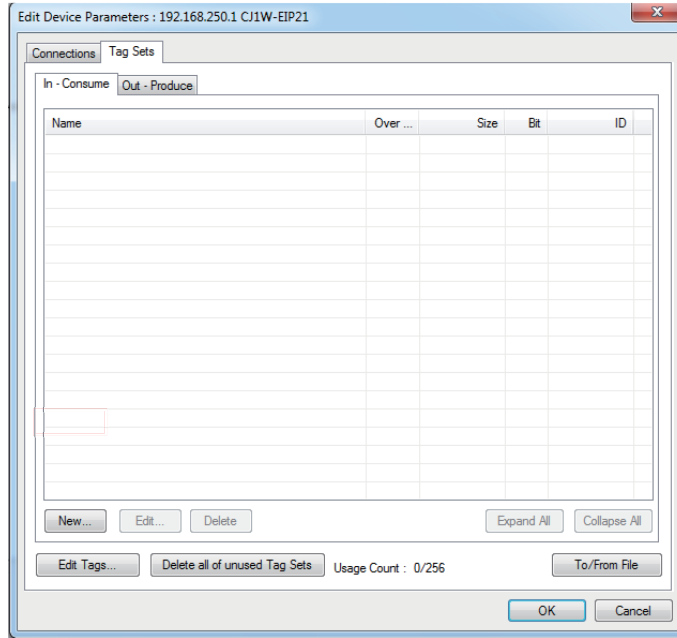

The Edit Tag Set Dialog Box is displayed.

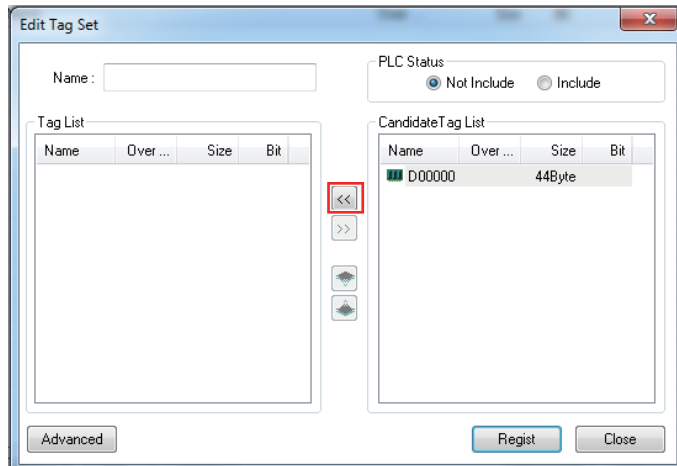

Enter the tag set name, select from the candidate tag list the tag to be a member, and add it by clicking the (add tag) << Button at the center or by double-clicking it.

After adding a member, you can register tag set by clicking [Register (R)].

In this example, we set "t_K6CM_Monitoring_Data" as the tag set name.



Additional Information

If you add a tag without specifying a tag set name and click [Register (R)], the tag name at the top of the tag list is automatically entered as the tag set name.

Continue to edit tag sets. Click [Close (C)] to end tag set editing .and return to the Edit Tag Set Dialog Box.

The registered tag set is displayed.

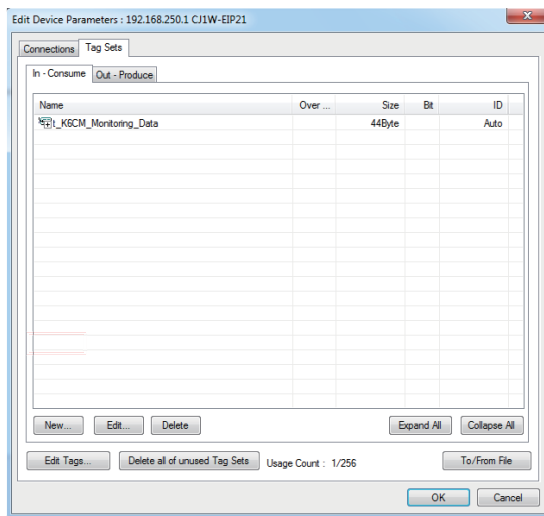

(2) EtherNet/IP Connection Settings

Set communications parameters for tag data link communications.

Select the [Connections] Tab in the Edit Device Parameters Dialog Box,

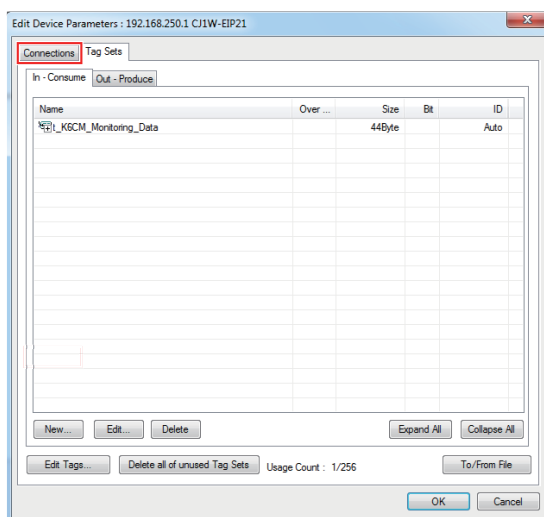

The Connection Edit is displayed in the Edit Device Parameters Dialog Box.

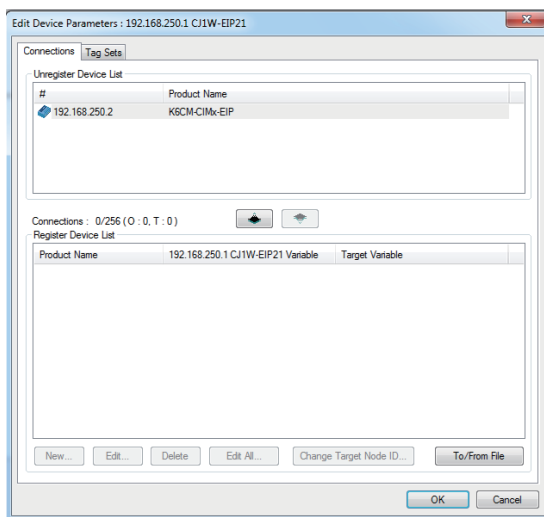

Select the K6CM series, and then click the middle  (Add device) Button to register the connection in the tag data link.

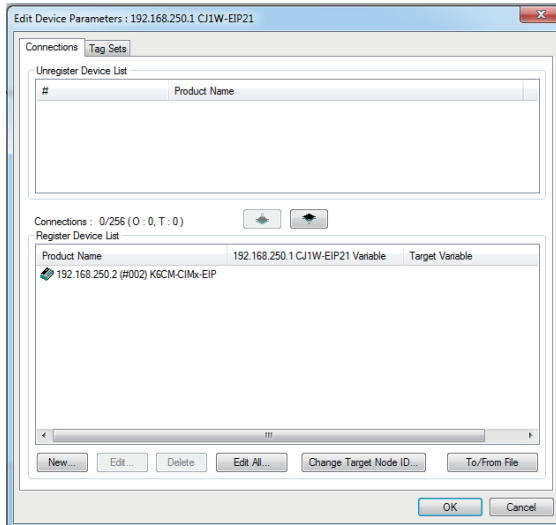

Select the K6CM series displayed in the registered device list, click [New (N) ...] or double-click the device, the Connection Allocation Dialog Box will be displayed.

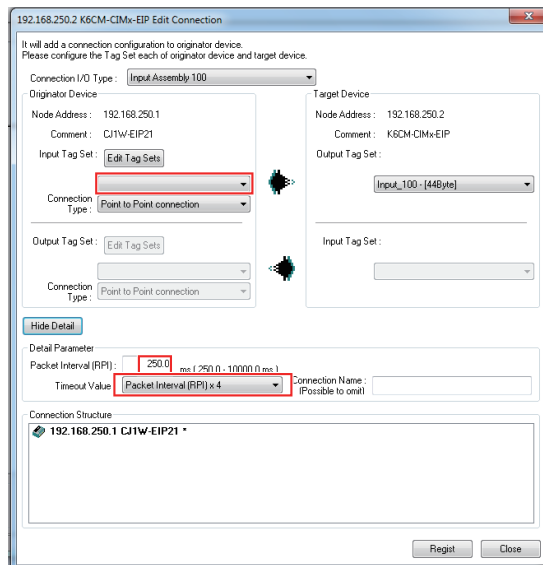

The default values of each parameter are displayed, and then set the following items.

- **Input tag set**
Select the tag set name edited in "(1) -2. Editing tag set" from the drop down list and set it.
- **Packet Interval (RPI)**
From the setting range of K6CM (250 ms to 10000 ms), set the data send interval from K6CM according to the system.
- **Timeout Value**
Select the timeout value at the occurrence of a communications error from the pull down list and set it. The value can be set by multiple of packet interval (RPI). (4 times, 8 times, 16 times, ..., 512 times)



Additional Information

If detailed parameters (i.e., packet interval (RPI), timeout value) are not displayed, it can be displayed by clicking [Detail View].

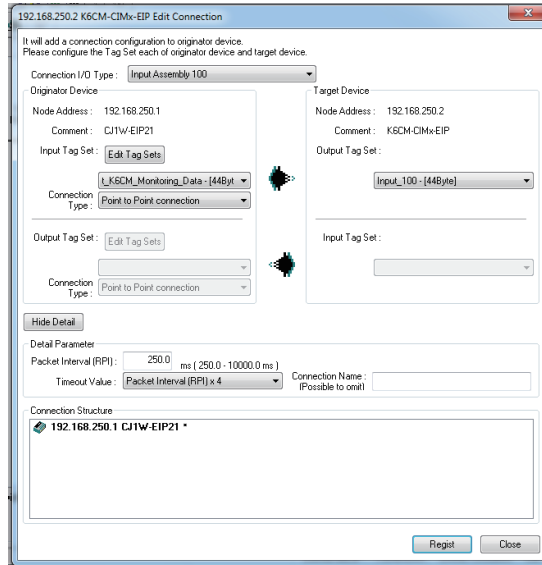

Click [Register] after connection allocations, then connection allocations are completed. Click [Close] and return from the Connection Allocation Dialog Box.

When the setting is completed, it is displayed as follows.

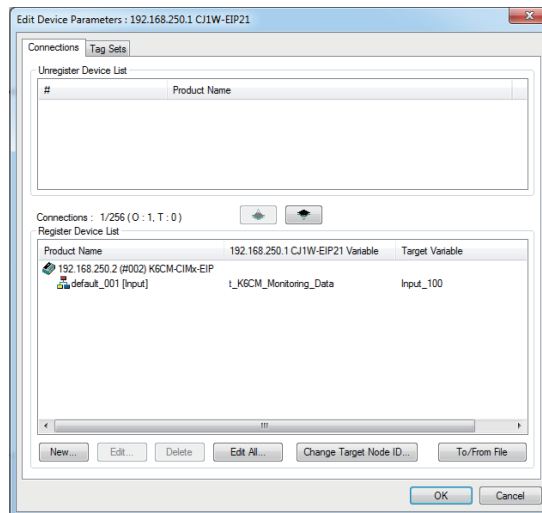

Setting is completed by clicking [OK] at the lower right.

6 Downloading settings

Connect online to the originator device and download the configuration settings.

(The EtherNet/IP tag data link communications setting of the K6CM series is fixed, so you do not need to download it to the K6CM.)

(1) Online

Select the communications interface to use from [Option (O)] | [Select Interface (I)] on the menu bar. (This operation is unnecessary if interface is not changed after interface setting.)

Then, select [Network (N)] | [Connection (C) ...] on the menu bar or click  (Online button) to go online to the EtherNet/IP network.

After online, select the originator device (PLC) to download, right click it and select [Parameter (P)] | [Download (D)] and download it.



Additional Information

For details on online and download operations, refer to the manual of the originator device.

For detailed settings, refer to the manual of the originator device.

- "SYSMAC CS/CJ Series EtherNet/IP Units Operation Manual (Cat. No.W465)"

A-9-2 Using the NJ/NX-series

With the Sysmac Studio Ver. 1.10 or higher, tag data link (EtherNet/IP connection) setting is possible when using NJ/NX-series PLC as a tag data link originator.

● Creating Network Variables (Input)

Create Input area in the PLC to receive Input data from K6CM devices.

The setting method for the NJ/NX-series PLC is shown below.

1 Starting the SysmacStudio

Start the SysmacStudio in one of the following ways.

- Double-click the shortcut icon of [Sysmac Studio] on the desktop.



- To start the Sysmac Studio, select [All Programs] | [OMRON] | [Sysmac Studio] | [Sysmac Studio] from the Windows Start Menu.

2 Creating Project File

Click [New Project] in the upper left in the start page.

To edit an existing project file, click [Open Project] and select the saved project.



Enter the project name, author, and comment in the [Project Properties Dialog] Box, select the device category, the device (PLC model) to use and its version, and then click the [Create] Button. (Only the project name is required.)

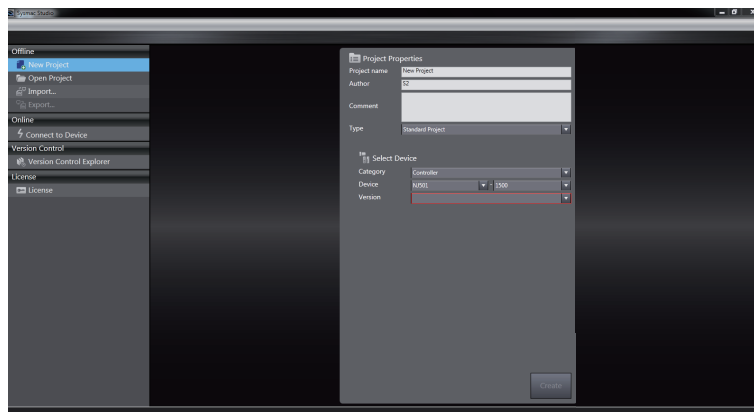

When you finish setting [Project Properties], the following screen will be displayed.

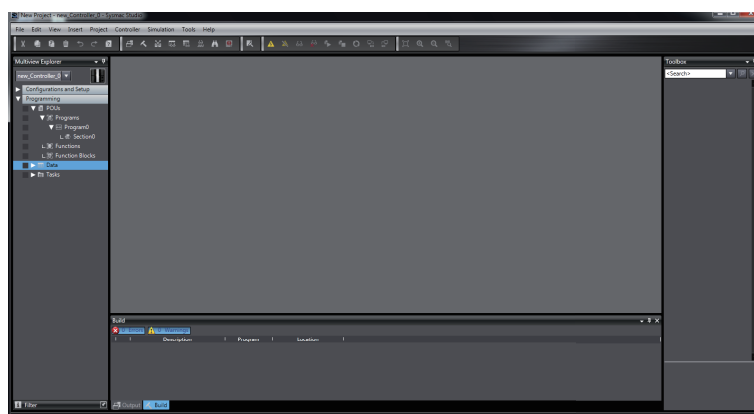

3 Creating Network Variables (Input)

Create network variables to be the input area in the PLC.

The K6CM device sends 44 bytes as Input data, therefore the network variable must be created as a structure variable or an array variable.

This section shows how to create structure variables. (For array variables, the following "(1) data type registration" are unnecessary.)

(1) Registering Data Type

Create a structure type as a basis by the following procedure to create a structure type network variable (44 bytes) for receiving K6CM's Input data.

(1)-1 Opening the Data Types Tab Page

Double-click [Data Type] under [Programming] | [Data] in the Multiview Explorer, or right-click [Data Type] and select [Edit] from the menu.

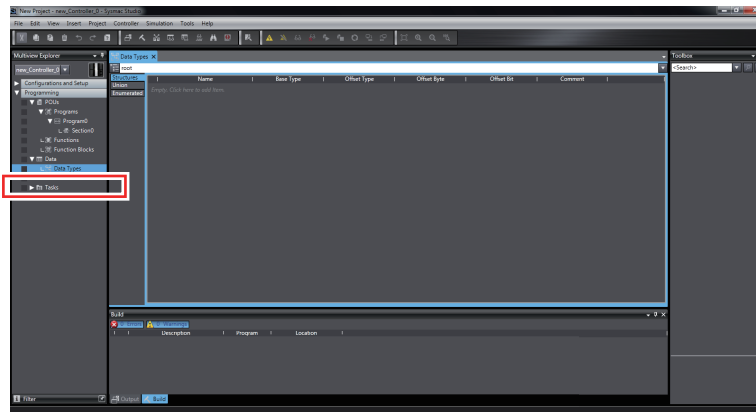

(1)-2 Registrating structure Type

Click the [Structures] Side Tab in the Data Type Editor, and then the Structure Data Type Editor is displayed.

In the Data Type Editor, press the [Insert] key or right-click and select [Create New Data Type (N)], and enter a structure name. As an example, we set "t_K6CM_CIM" here. An error is displayed because there is no structure member registration at this time.

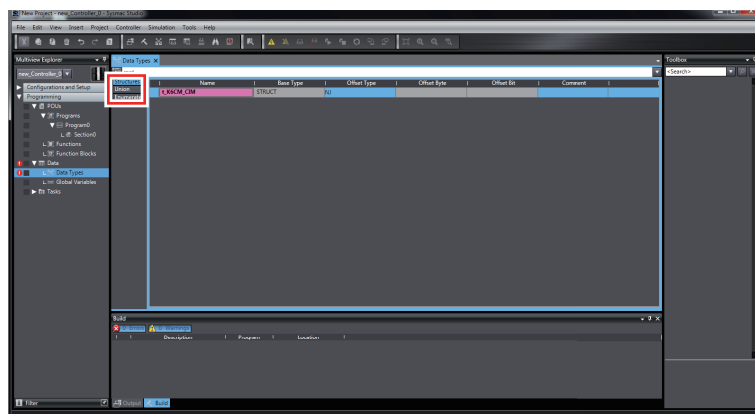

(1)-3 Adding structure Members

Right-click the structure data type you just created and select [Create New Member(M)] from the menu. Register members and data types to match data received from the K6CM device.

The registered Pane will be as follows. Data that are not defined as tag data link are registered as reserved area. The total size is 44 bytes. The member name can be changed as appropriate.

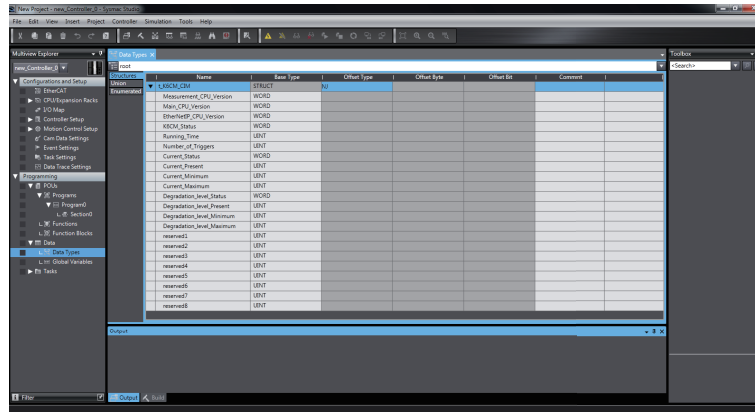

(2) Network Variables (Input) Definition

(2)-1 Opening the Global Variable Tab Page

Double-click Global Variables under [Programming] | [Data] in the Multiview Explorer, or right-click [Global Variables] and select [Edit] from the menu.

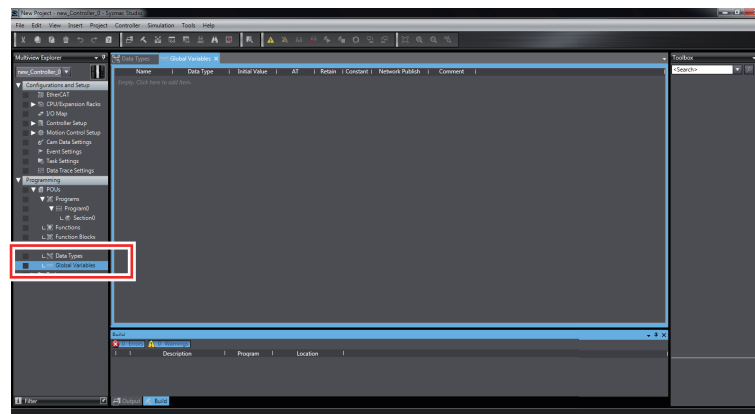

(2)-2 Registering Network Variables (Input)

In the global variable table, press the [Insert] key or right-click and select [Create New (N)], and enter a variable name. Next, change [Data Type] to the structure type name created in "(1) Registering Data Type", and change the Network Publish attribute to [Input] from the pull down list. In this example, the name of the network variable (input) is set to "K6CM_CIM_Monitor_Data" and the data type is set to "t_K6CM_CIM" created in "(1) Registering Data Type".

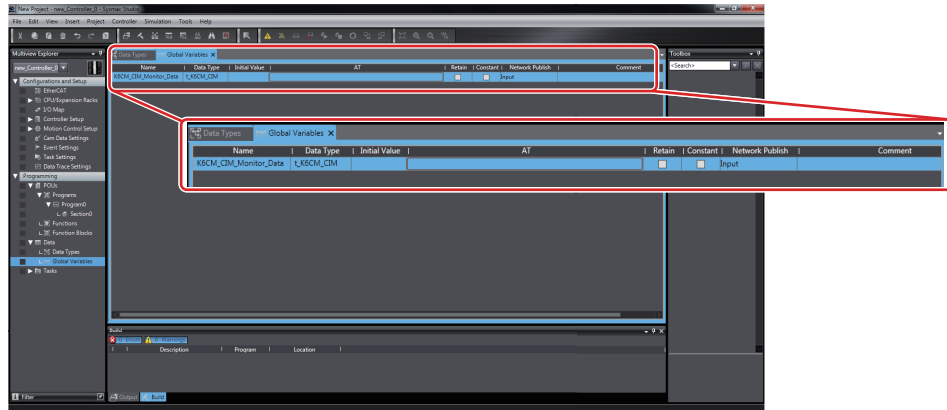

Associate the network variables created here with the tags used in the EtherNet/IP connection settings described below.



Additional Information

To process the input data as an array variable instead of a structure variable, create a 44-byte network variable with an array of UINT as [Data Type] in the following example.

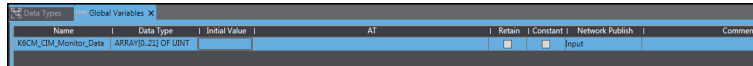

4 EtherNet/IP Connection Settings

After creating the network variables (input), perform setting the EtherNet/IP connection for EtherNet/IP tag data link communications.

(1) Opening the EtherNet/IP Device List Tab Page

Select [EtherNet/IP Connection Settings(N)] from the [Tools(T)] from the menu bar.

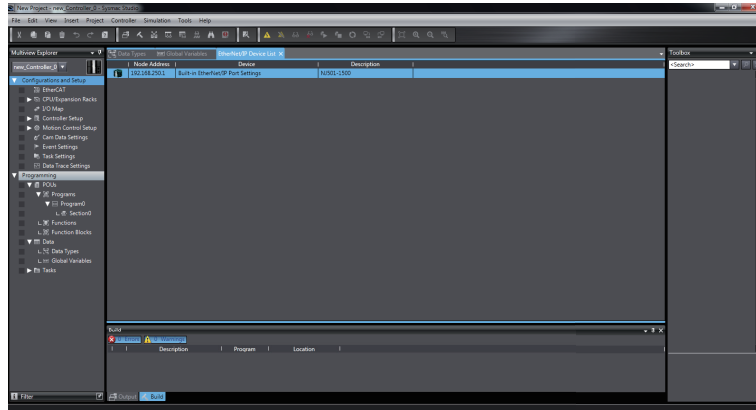

(2) Opening the EtherNet/IP Connection Settings (Tag Set Display)

Select the EtherNet/IP originator device and double-click it, or right-click the originator device and select [Edit (E)]. If you use the built-in EtherNet/IP port, only the built-in EtherNet port is displayed as an originator device. In that case select it, highlight it and then operate it.

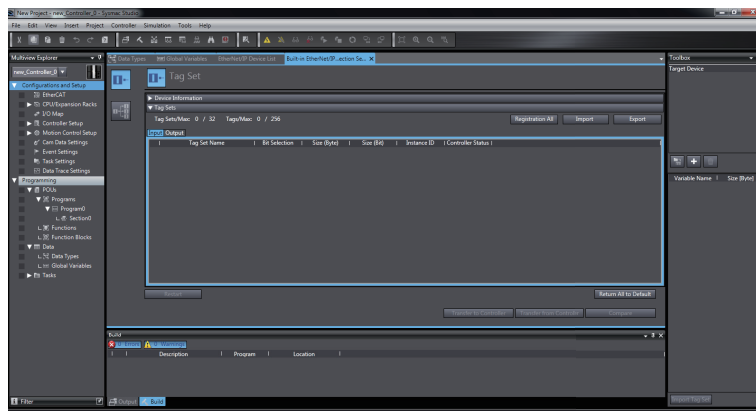

(3) Registering the K6CM Devices to the Network

Make the following settings so that the K6CM device operates as a target.

(3)-1 Installing EDS Files

To configure K6CM as an EtherNet/IP tag data link communications target, install the EDS file containing the configuration information of the K6CM in the SysmacStudio. Once this installation is done, this operation is unnecessary from the next setting.

This operation is unnecessary because it is preinstalled if you use the SysmacStudio Ver.1.40 or higher. If you are using an earlier version, install it using the EDS file stored on the CD shipped with the K6CM device.

Right-click anywhere in the [Target Device] List in the Toolbox on the right of the Ether-Net/IP Connection Setting Tab Page and select [Display EDS Library] from the menu.

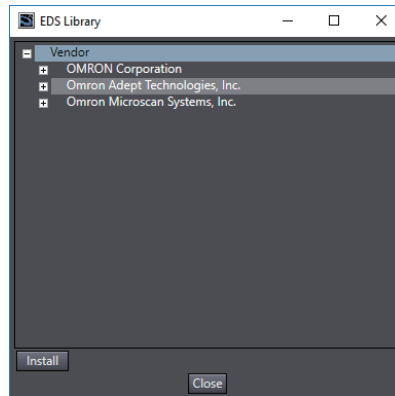

Click the [Install] Button at the bottom left, select the following EDS file, click [Open] and install it.

Model name of the K6CM	EDS file name
K6CM-CI2M	K6CM_CI2M_EIP_R3.eds
K6CM-VBM	K6CM_VBM_EIP_R3.eds
K6CM-ISM	K6CM_ISM_EIP_R3.eds

When installation is completed, the category "Motor Condition Monitoring Device" and the registered K6CM devices are displayed under the tree of the OMRON Corporation in the EDS Library Dialog Box.

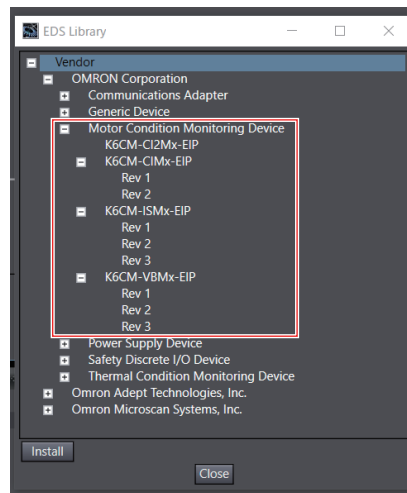

(3)-2 Adding K6CM Devices to the Network

Click the **+** (Add Target Device) Button in the [Toolbox] on the right of the EtherNet/IP Connection Setting Tab Page.

As in the example below, enter the node address (i.e. IP address) and select the model and revision from the pull down list.

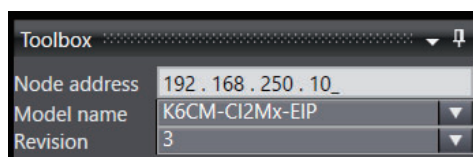

Click the [Add] Button at the bottom of the toolbox. The K6CM device will be added as a target device.

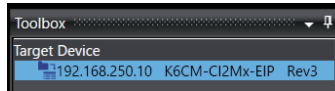

(4) Tag Set Editing

Map the K6CM Input data to the memory area of the PLC using the EtherNet/IP tag data link by associating the network variable (input) of the PLC with the tag used in the network. As a method of editing the tag set, there is a method of registering all tag sets, and a method of individual registering by right-clicking and selecting Create New Tag Set. Here, the method of registering is described.

(4)-1 Open Tag Set Registration Setting Dialog Box

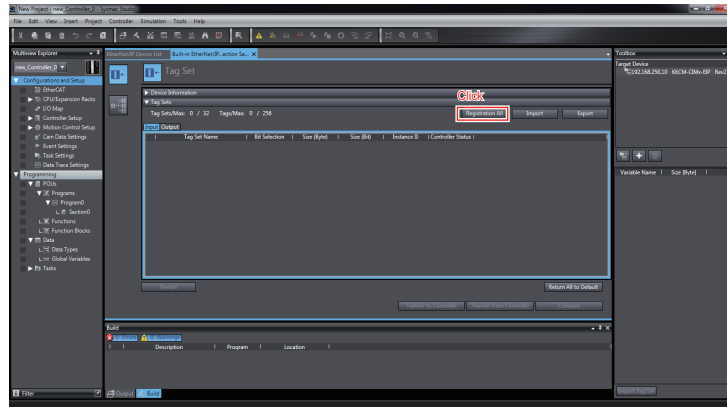

Click the [Registration All] Button in the Tag Set Pane, a list of network-published global variables will be displayed. In this example, "K6CM_CIM_Monitor_Data" which was registered as a network variable (input) is displayed.

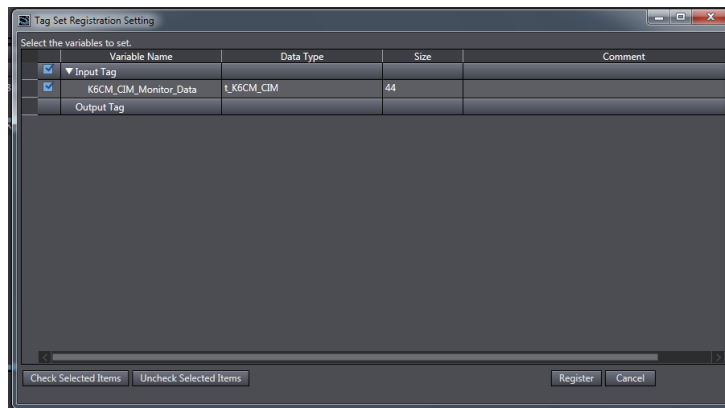

(4)-2 Registering All Tag Sets

Check the check box of the network variable to be used as the input tag among the network-published variables and click the [Register] Button, and then the specified tag is displayed in the tag set Pane.

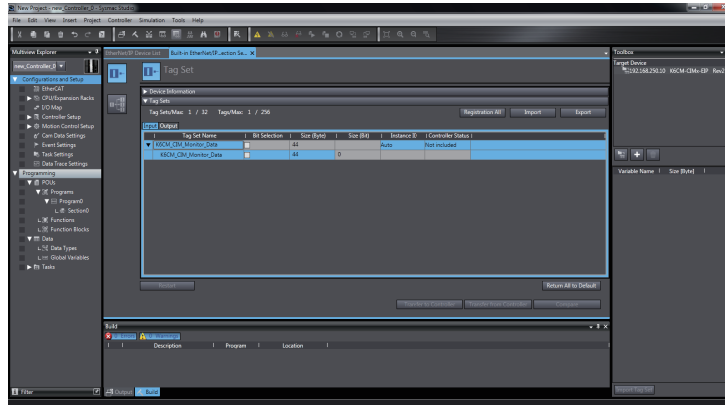

If you perform the registering all tag set, the tag set and the tag are displayed as the same name.

The tag set names displayed can be used as connection settings. (Use these tag set names, when configuring EtherNet/IP connections using the Network Configurator.)

You can change the tag set names as required.

Also, the tag name displayed under the tag set name must match the variable name registered as a network variable (input).



Additional Information

If you create connection settings using the Network Configurator, you can share the tag set names and tag names of the PLC you edit here with the Network Configurator.

(5) Opening the EtherNet/IP Connection Settings (Connection Display)

Click the Connection Button at the upper left of the EtherNet/IP Connection Settings (Tag Set Display) to display the Connection.

(6) Target Devices Registration to the Connection Settings of the Originator

Register the K6CM devices to the connection settings of the originator device (PLC).

Right click and select [Create New (A)] or click the **+** (New) Button in the EtherNet/IP Connection Setting Tab Page, Then select the K6CM from the pull-down list as the target device. (This operation can also be performed by double clicking the K6CM in the [Target Device] Pane of the Toolbox.)

Target Device	Connection Name	Connection I/O Type	Input/Output	Target Variable	Size [Byte]	Originator Variable	Size [Byte]	Connection Type	RPI [ms]	Timeout Value
192.168.250.10 K6CM-C6ZMx-EP Rev 3	defRIP_001	Input/Assembly	Input					Point to Point connection	50.0	RPI x 4

Next, when setting [Target Variable], if you press [Ctrl] + [Space] key at the same time, the selectable ID number is displayed, so select the ID number to use.

For [Originator Variable], select the tag set created in "(4) Editing tag set" from the pull down list and set it.

In [RPI (ms)], from the setting range of the K6CM device (250 ms to 10,000 ms), set the data send interval from the K6CM device according to the system. Select the [Timeout Value] from the pull-down list and set it.

The timeout time when a communication error occurs can be calculated as follows.

Timeout time = RPI (ms) × multiple of RPI set by timeout value (4 times, 8 times, 16 times, ..., 512 times)

This completes the tag data link setting. Go online to the originator device (PLC) and download the EtherNet/IP tag data link settings to the PLC by clicking [Transfer to Controller] Button.

(The EtherNet/IP tag data link communications setting of the K6CM series is fixed, so you do not need to download it to the K6CM.)

A

A-10 Expansion Error Code of the CIP Message Communications

This section describes the expansion error code when an explicit error occurs in the CIP message communications command.

The format of the expansion error code is as follows.

Value: 16#XXYYZZZZ

Data type: DWORD

(XX: General Status, YY: Additional Status size (unit: WORD), ZZZZ: Additional Status)

However, ZZZZ of Additional Status is enabled only when XX of General Status is 01 (hex). In other cases, size YY is 00 and ZZZZ of Additional Status does not exist.

A-10-1 General Status

General Status (hex)	Status Name	Description of Status
00	Success	Service was successfully performed by the object specified.
01	Connection failure	A connection related service failed along the connection path.
02	Resource unavailable	Resources needed for the object to perform the requested service were unavailable.
03	Invalid parameter value	See Status Code 20 hex, which is the preferred value to use for this condition.
04	Path segment error	The path segment identifier or the segment syntax was not understood by the processing node. Path processing shall stop when a path segment error is encountered.
05	Path destination unknown	The path is referencing an object class, instance or structure element that is not known or is not contained in the processing node. Path processing shall stop when a path destination unknown error is encountered.
06	Partial transfer	Only part of the expected data was transferred.
07	Connection lost	The messaging connection was lost.
08	Service not supported	The requested service was not implemented or was not defined for this Object Class/Instance.
09	Invalid attribute value	Invalid attribute data detected.
0A	Attribute list error	An attribute in the Get_Attribute_List or Set_Attribute_List response has a non-zero status.
0B	Already in requested mode/state	The object is already in the mode/state being requested by the service.
0C	Object state conflict	The object cannot perform the requested service in its current mode/state.
0D	Object already exists	The requested instance of object to be created already exists.
0E	Attribute not settable	A request to modify a non-modifiable attribute was received.
0F	Privilege violation	A permission/privilege check failed.
10	Device state conflict	The device's current mode/state prohibits the execution of the requested service.
11	Reply data too large	The data to be transmitted in the response buffer is larger than the allocated response buffer.
12	Fragmentation of a primitive value	The service specified an operation that is going to fragment a primitive data value, i.e. half a REAL data type.

General Status (hex)	Status Name	Description of Status
13	Not enough data	The service did not supply enough data to perform the specified operation.
14	Attribute not supported	The attribute specified in the request is not supported.
15	Too much data	The service supplied more data than was expected.
16	Object does not exist	The object specified does not exist in the device.
17	Service fragmentation sequence not in progress	The fragmentation sequence for this service is not currently active for this data.
18	No stored attribute data	The attribute data of this object was not saved prior to the requested service.
19	Store operation failure	The attribute data of this object was not saved due to a failure during the attempt.
1A	Routing failure (request packet too large)	The service request packet was too large for transmission on a network in the path to the destination. The routing device was forced to abort the service.
1B	Routing failure (response packet too large)	The service response packet was too large for transmission on a network in the path from the destination. The routing device was forced to abort the service.
1C	Missing attribute list entry data	The service did not supply an attribute in a list of attributes that was needed by the service to perform the requested behavior.
1D	Invalid attribute value list	The service is returning the list of attributes supplied with status information for those attributes that were invalid.
1E	Embedded service error	An embedded service resulted in an error.
20	Invalid parameter	A parameter associated with the request was invalid. This code is used when a parameter does not meet the requirements of this specification and/or the requirements defined in an Application Object Specification.
21	Write-once value or medium already written	An attempt was made to write to a write-once medium (e.g. WORM drive, PROM) that has already been written, or to modify a value that cannot be changed once established.
22	Invalid Reply Received	An invalid reply is received (e.g. reply service code does not match the request service code, or reply message is shorter than the minimum expected reply size). This status code can serve for other causes of invalid replies.
23-24		Reserved by CIP for future extensions.
25	Key Failure in path	The Key Segment that was included as the first segment in the path does not match the destination module. The object specific status shall indicate which part of the key check failed.
26	Path Size Invalid	The size of the path which was sent with the Service Request is either not large enough to allow the Request to be routed to an object or too much routing data was included.
27	Unexpected attribute in list	An attempt was made to set an attribute that is not able to be set at this time.
28	Invalid Member ID	The Member ID specified in the request does not exist in the specified Class/Instance/Attribute.
29	Member not settable	A request to modify a non-modifiable member was received.
2B-CF		Reserved by CIP for future extensions.
D0-FF	Reserved for Object Class and service errors	This range of error codes is to be used to indicate Object Class specific errors. Use of this range should only be performed when none of the Error Codes presented in this table accurately reflect the error that was encountered. The Additional Code field can be used to explain the General Error Code in more detail.

A-10-2 Additional Status When General Status Is 01 hex

General Status (hex)	Additional Status (hex)	Explanation
01	0100	Connection in Use or Duplicate Forward Open.
01	0103	Transport Class and Trigger combination not supported.
01	0106	Ownership Conflict.
01	0107	Connection not found at target application.
01	0108	Invalid Connection Type. Indicates a problem with either the Connection Type or Priority of the Connection.
01	0109	Invalid Connection Size.
01	0110	Device not configured.
01	0111	RPI not supported. May also indicate problem with connection time-out multiplier, or production inhibit time.
01	0113	Connection Manager cannot support any more connections.
01	0114	Either the Vendor Id or the Product Code in the key segment did not match the device.
01	0115	Product Type in the key segment did not match the device.
01	0116	Major or Minor Revision information in the key segment did not match the device.
01	0117	Invalid Connection Point.
01	0118	Invalid Configuration Format.
01	0119	Connection request fails since there is no controlling connection currently open.
01	011A	Target Application cannot support any more connections.
01	011B	RPI is smaller than the Production Inhibit Time.
01	0203	Connection cannot be closed since the connection has timed out.
01	0204	Unconnected Send timed out waiting for a response.
01	0205	Parameter Error in Unconnected Send Service.
01	0206	Message too large for Unconnected message service.
01	0207	Unconnected acknowledge without reply.
01	0301	No buffer memory available.
01	0302	Network Bandwidth not available for data.
01	0303	No Tag filters available.
01	0304	Not Configured to send real-time data.
01	0311	Port specified in Port Segment Not Available.
01	0312	Link Address specified in Port Segment Not Available.
01	0315	Invalid Segment Type or Segment Value in Path.
01	0316	Path and Connection not equal in close.
01	0317	Either Segment not present or Encoded Value in Network Segment is invalid.
01	0318	Link Address to Self Invalid.
01	0319	Resources on Secondary Unavailable.
01	031A	Connection already established.
01	031B	Direct connection already established.
01	031C	Miscellaneous.
01	031D	Redundant connection mismatch.
01	031E	There are no more available reception resources in the sending module.
01	031F	No connection resources exist for target path.
01	0320- 07FF	unused.

A-11 Version Compatibility

This section describes version upgrades of the K6CM series and the support status of Motor condition monitoring Tool.

A-11-1 Version Upgrades of the K6CM Series

The following version upgrades have been performed up until now for the K6CM device.

K6CM device				Additional functions
Monitor Type	Model	Eip cpu version	CIP revision (EDS)	
Comprehensive current diagnosis	K6CM-CI2M*1	1.2	Rev.3	Degradation level 2 measurement function Monitoring delay time settings Individual setting of moving average times Display auto switching mode
		K6CM-CIM	1.1	Rev.2
			1.0	Rev.1
Vibration & temperature	K6CM-VBM	1.2	Rev.3	Monitoring delay time settings Display auto switching mode
		1.1	Rev.2	Transistor output method settings
		1.0	Rev.1	First release
Insulation resistance	K6CM-ISM	1.2	Rev.3	Monitoring delay time settings Display auto switching mode
		1.1	Rev.2	Transistor output method settings
		1.0	Rev.1	First release

*1. Released from Eip cpu version 1.2 as successor to the K6CM-CIM model.

A-11-2 Support Correspondence between the K6CM Device and Motor Condition Monitoring Tool

The supported versions of the K6CM device and the Motor condition monitoring Tool are shown below. Use a supported version combination.

K6CM device		Motor condition monitoring Tool supported version
Eip cpu version	CIP revision (EDS)	
1.2	Rev.3	Ver.1.3.0.0 or later
1.1	Rev.2	Ver.1.1.0.0 or later
1.0	Rev.1	Ver.1.0.0.2 or later

A-11-3 Motor Condition Monitoring Tool Version Compatibility

When you upgrade the version of Motor condition monitoring Tool, the project files created with the old tool version can be used with the new tool version.



Precautions for Correct Use

Do not use project files created with the new tool version with the old tool version. When sharing project folders between PCs, use the same tool version.

A-11-4 BOOTP Server Connection Error State LED Lighting Differences

The state of the BOOTP server connection error state LED differs depending on the Main cpu version.

Indicators		Main cpu version 1.1 and earlier		Main cpu version 1.2 or later	
Symbol	Name	Color	Status	Color	Status
MS	Module status indication (Module Status)	Green	Lit.	Green	Flashes at 1-s intervals.
NS	Network status indication (Network Status)	Red	Flashes at 1-s intervals.	---	Not lit.



Index



Index

A		L	
Add a Device to an Existing Project	6-24	Log file	4-5
AGE	2-4	M	
Alarm bar display	2-3	maximum value and minimum value	3-13
alarm latch	3-14	Modbus TCP	9-2
Alarm Setting Values (threshold value)	A-15	MON	2-4
C		monitor with the front alarm bar	7-6
CIP message communications	8-3, 8-12	monitor with the transistor outputs	7-7
comprehensive alarm	3-13	monitoring cycle	7-9
Comprehensive Current Diagnosis Type	1-4, 1-10, A-8	Monitoring Delay Settings	3-9
Critical	3-13	monitoring type	2-3
CT (current transformer)		Motor condition monitoring Tool	4-2
for Comprehensive Current Diagnosis Type	5-2	N	
D		Network Wiring	5-29
degradation level 1	1-5	Normal	3-13
degradation level 2	1-5	P	
Diagram of Terminal Description	5-24	Parameters setting	6-23
dimensions	5-2	Procedure	1-14
E		Project file	4-4
ERR	2-4	Push-In Plus Terminal Blocks	5-19
Ethernet switches recommended	5-29	S	
EtherNet/IP	8-2	Setting Alarm	3-19
I		Special CT	2-10
I/O wiring	5-25	Special Current Transformer (CT)	A-10
Installation and Connection of Insulation Resistance		Specifications	A-4
Sensor (Special ZCT (IRT))	5-13	System Configuration	1-9
Installation and Connection of Special CT	5-15	T	
Installation of Vibration Sensor Head	5-7	tag data link	8-3, 8-5
Installing	5-5	Trigger mode	3-3, 3-4, 3-5, 7-3
Insulation Resistance Sensor		U	
(Special ZCT (IRT))	2-13, 5-4, A-13	Unit of measurement value	2-3
Insulation Resistance Type	1-6, 1-13, A-9	V	
IP address changing	4-38	Vibration & Temperature Sensor	5-3, 5-16, A-12
IP address initial value	4-28	Vibration & Temperature Type	1-6, 1-12, A-9
K		W	
K6CM-CI2	1-10, A-8	Warning	3-13
K6CM-CICB	A-10		
K6CM-ISM	1-13, A-9		
K6CM-ISZB	A-13		
K6CM-VBM	1-12, A-9		
K6CM-VBS	A-12		

OMRON Corporation Industrial Automation Company
Kyoto, JAPAN

Contact: www.ia.omron.com

Regional Headquarters

OMRON EUROPE B.V.

Wegalaan 67-69, 2132 JD Hoofddorp
The Netherlands
Tel: (31)2356-81-300/Fax: (31)2356-81-388

OMRON ASIA PACIFIC PTE. LTD.

No. 438A Alexandra Road # 05-05/08 (Lobby 2),
Alexandra Technopark,
Singapore 119967
Tel: (65) 6835-3011/Fax: (65) 6835-2711

OMRON ELECTRONICS LLC

2895 Greenspoint Parkway, Suite 200
Hoffman Estates, IL 60169 U.S.A.
Tel: (1) 847-843-7900/Fax: (1) 847-843-7787

OMRON (CHINA) CO., LTD.

Room 2211, Bank of China Tower,
200 Yin Cheng Zhong Road,
PuDong New Area, Shanghai, 200120, China
Tel: (86) 21-5037-2222/Fax: (86) 21-5037-2200

Authorized Distributor:

© OMRON Corporation 2017-2020 All Rights Reserved.
In the interest of product improvement,
specifications are subject to change without notice.

Cat. No. N219-E1-12

0420