

4 Megabit (512K x 8) SuperFlash EEPROM

SST28SF040 / SST28LF040 / SST28VF040



Data Sheet

FEATURES:

- **Single Voltage Read and Write Operations**
 - 5.0V-only for the SST28SF040
 - 3.0-3.6V for the SST28LF040
 - 2.7-3.6V for the SST28VF040
- **Superior Reliability**
 - Endurance: 100,000 Cycles (typical)
 - Greater than 100 years Data Retention
- **Memory Organization: 512K x 8**
- **Sector Erase Capability: 256 bytes per Sector**
- **Low Power Consumption**
 - Active Current: 15 mA (typical) for 5.0V and 10 mA (typical) for 3.0-3.6V/2.7-3.6V
 - Standby Current: 5 μ A (typical)
- **Fast Sector Erase/Byte Program Operation**
 - Byte Program Time: 35 μ s (typical)
 - Sector Erase Time: 2 ms (typical)
 - Complete Memory Rewrite: 20 sec (typical)
- **Fast Read Access Time**
 - 5.0V-only operation: 120 and 150 ns
 - 3.0-3.6V operation: 200 and 250 ns
 - 2.7-3.6V operation: 250 and 300 ns
- **Latched Address and Data**
- **Hardware and Software Data Protection**
 - 7-Read-Cycle-Sequence Software Data Protection
- **End of Write Detection**
 - Toggle Bit
 - Data# Polling
- **TTL I/O Compatibility**
- **JEDEC Standard**
 - Flash EEPROM Pinouts
- **Packages Available**
 - 32-Pin PDIP
 - 32-Pin PLCC
 - 32-Pin TSOP (8mm x 20mm)

PRODUCT DESCRIPTION

The SST28SF040/28LF040/28VF040 are 512K x 8 bit CMOS sector erase, byte program EEPROMs. The SST28SF040/28LF040/28VF040 are manufactured using SST's proprietary, high performance CMOS SuperFlash EEPROM Technology. The split-gate cell design and thick oxide tunneling injector attain better reliability and manufacturability compared with alternative approaches. The SST28SF040/28LF040/28VF040 erase and program with a single power supply. The SST28SF040/28LF040/28VF040 conform to JEDEC standard pinouts for byte wide memories and are compatible with existing industry standard EPROM, and flash EEPROM pinouts.

Featuring high performance programming, the SST28SF040/28LF040/28VF040 typically byte program in 35 μ s. The SST28SF040/28LF040/28VF040 typically sector erase in 2 ms. Both program and erase times can be optimized using interface features such as Toggle bit or Data# Polling to indicate the completion of the write cycle. To protect against an inadvertent write, the SST28SF040/28LF040/28VF040 have on chip hardware and software data protection schemes. Designed, manufactured, and tested for a wide spectrum of applications, the SST28SF040/28LF040/28VF040 are offered with a guaranteed sector endurance of 10^4 or 10^3 cycles. Data retention is rated greater than 100 years.

The SST28SF040/28LF040/28VF040 are best suited for applications that require reprogrammable nonvolatile mass storage of program, configuration, or data memory. For all system applications, the SST28SF040/28LF040/28VF040 significantly improve performance and reliability, while lowering power consumption when compared with floppy diskettes or EPROM approaches. EEPROM technology makes possible convenient and economical updating of codes and control programs on-line. The SST28SF040/28LF040/28VF040 improve flexibility, while lowering the cost of program and configuration storage application.

The functional block diagram shows the functional blocks of the SST28SF040/28LF040/28VF040. Figures 1 and 2 show the pin assignments for the 32 pin TSOP, 32 pin PDIP, and 32 pin PLCC packages. Pin description and operation modes are described in Tables 1 through 4.

Device Operation

Commands are used to initiate the memory operation functions of the device. Commands are written to the device using standard microprocessor write sequences. A command is written by asserting WE# low while keeping CE# low. The address bus is latched on the falling edge of WE# or CE#, whichever occurs last. The data bus is latched on the rising edge of WE# or CE#, whichever occurs first. Note, during the software data protection sequence the addresses are latched on the rising edge of OE# or CE#, whichever occurs first.



4 Megabit SuperFlash EEPROM SST28SF040 / SST28LF040 / SST28VF040

Command Definitions

Table 3 contains a command list and a brief summary of the commands. The following is a detailed description of the operations initiated by each command.

Sector Erase Operation

The Sector Erase operation erases all bytes within a sector and is initiated by a setup command and an execute command. A sector contains 256 bytes. This sector erasability enhances the flexibility and usefulness of the SST28SF040/28LF040/28VF040, since most applications only need to change a small number of bytes or sectors, not the entire chip.

The setup command is performed by writing 20H to the device. The execute command is performed by writing D0H to the device. The Erase operation begins with the rising edge of the WE# or CE#, whichever occurs first and terminates automatically by using an internal timer. The end of Erase can be determined using either Data# Polling, Toggle Bit, or Successive Reads detection methods. See Figure 8 for timing waveforms.

The two-step sequence of a setup command followed by an execute command ensures that only memory contents within the addressed sector are erased and other sectors are not inadvertently erased.

Sector Erase Flowchart Description

Fast and reliable erasing of the memory contents within a sector is accomplished by following the sector erase flowchart as shown in Figure 17. The entire procedure consists of the execution of two commands. The Sector Erase operation will terminate after a maximum of 4 ms. A Reset command can be executed to terminate the Sector Erase operation; however, if the Erase operation is terminated prior to the 4 ms time-out, the sector may not be fully erased. A Sector Erase command can be reissued as many times as necessary to complete the erase operation. The SST28SF040/28LF040/28VF040 cannot be "overerased".

Chip Erase Operation

The Chip Erase operation is initiated by a setup command (30H) and an execute command (30H). The Chip Erase operation allows the entire array of the SST28SF040/28LF040/28VF040 to be erased in one operation, as opposed to 2048 Sector Erase operations. Using the Chip Erase operation will minimize the time to

rewrite the entire memory array. The Chip Erase operation will terminate after a maximum of 20 ms. A Reset command can be executed to terminate the Erase operation; however, if the Chip Erase operation is terminated prior to the 20 ms time-out, the chip may not be completely erased. If an erase error occurs a Chip Erase command can be reissued as many times as necessary to complete the Chip Erase operation. The SST28SF040/28LF040/28VF040 cannot be "overerased". (See Figure 7)

Byte Program Operation

The Byte Program operation is initiated by writing the setup command (10H). Once the program setup is performed, programming is executed by the next WE# pulse. See Figures 4 and 5 for timing waveforms. The address bus is latched on the falling edge of WE# or CE#, whichever occurs last. The data bus is latched on the rising edge of WE# or CE#, whichever occurs first, and begins the Program operation. The Program operation is terminated automatically by an internal timer. See Figure 15 for the programming flowchart.

The two-step sequence of a setup command followed by an execute command ensures that only the addressed byte is programmed and other bytes are not inadvertently programmed.

The Byte Program Flowchart Description

Programming data into the SST28SF040/28LF040/28VF040 is accomplished by following the Byte Program flowchart shown in Figure 15. The Byte Program command sets up the byte for programming. The address bus is latched on the falling edge of WE# or CE#, whichever occurs last. The data bus is latched on the rising edge of WE# or CE#, whichever occurs first and begins the Program operation. The end of program can be detected using either the Data# Polling, Toggle bit, or Successive reads.

Reset Operation

The Reset command is provided as a means to safely abort the Erase or Program command sequences. Following either setup commands (Erase or Program) with a write of FFH will safely abort the operation. Memory contents will not be altered. After the Reset command, the device returns to the Read mode. The Reset command does not enable Software Data Protection. See Figure 6 for timing waveforms.



4 Megabit SuperFlash EEPROM SST28SF040 / SST28LF040 / SST28VF040

Read

The Read operation is initiated by setting CE#, and OE# to logic low and setting WE# to logic high (See Table 2). See Figure 3 for Read memory timing waveform. The Read operation from the host retrieves data from the array. The device remains enabled for Read until another operation mode is accessed. During initial power-up, the device is in the Read mode and is Software Data protected. The device must be unprotected to execute a Write command.

The Read operation of the SST28SF040/28LF040/28VF040 are controlled by OE# and CE# at logic low. When CE # is high, the chip is deselected and only standby power will be consumed. OE# is the output control and is used to gate data from the output pins. The data bus is in high impedance state when CE# or OE# are high.

Read ID operation

The Read ID operation is initiated by writing a single command (90H). A read of address 0000H will output the manufacturer's code (BFH). A read of address 0001H will output the device code (04H). Any other valid command will terminate this operation.

Data Protection

In order to protect the integrity of nonvolatile data storage, the SST28SF040/28LF040/28VF040 provide both hardware and software features to prevent inadvertent writes to the device, for example, during system power-up or power-down. Such provisions are described below.

Hardware Data Protection

The SST28SF040/28LF040/28VF040 are designed with hardware features to prevent inadvertent writes. This is done in the following ways:

1. Write Inhibit Mode: OE# low, CE#, or WE# high will inhibit the Write operation.
2. Noise/Glitch Protection: A WE# pulse width of less than 15 ns will not initiate a write cycle.
3. V_{CC} Power Up/Down Detection: The Write operation is inhibited when V_{CC} is less than 2.5V.
4. After power-up the device is in the Read mode and the device is in the Software Data Protect state.

Software Data Protection (SDP)

The SST28SF040/28LF040/28VF040 have software methods to further prevent inadvertent writes. In order to perform an Erase or Program operation, a two-step command sequence consisting of a set-up command followed by an execute command avoids inadvertent erasing and programming of the device.

The SST28SF040/28LF040/28VF040 will default to Software Data Protection after power up. A sequence of seven consecutive reads at specific addresses will unprotect the device. The address sequence is 1823H, 1820H, 1822H, 0418H, 041BH, 0419H, 041AH. The address bus is latched on the rising edge of OE# or CE#, whichever occurs first. A similar seven read sequence of 1823H, 1820H, 1822H, 0418H, 041BH, 0419H, 040AH will protect the device. Also refer to Figures 9 and 10 for the 7 read cycle sequence Software Data Protection. The I/O pins can be in any state (i.e., high, low, or tristate).

Write Operation Status Detection

The SST28SF040/28LF040/28VF040 provide three means to detect the completion of a write cycle, in order to optimize the system write cycle time. The end of a write cycle (Erase or Program) can be detected by three means: 1) monitoring the Data# Polling bit; 2) monitoring the Toggle bit; or 3) by two successive reads of the same data. These three detection mechanisms are described below.

The actual completion of the nonvolatile Write is asynchronous with the system; therefore, either a Data# Polling or Toggle Bit read may be simultaneous with the completion of the write cycle. If this occurs, the system may possibly get an erroneous result, i.e., valid data may appear to conflict with the DQ used. In order to prevent spurious rejection, if an erroneous result occurs, the software routine should include a loop to read the accessed location an additional two (2) times. If both reads are valid, then the device has completed the write cycle, otherwise the rejection is valid.

Data# Polling (DQ₇)

The SST28SF040/28LF040/28VF040 feature Data# Polling to indicate the Write operation status. During a Write operation, any attempt to read the last byte loaded during the byte-load cycle will receive the complement of the true data on DQ₇. Once the write cycle is completed, DQ₇ will show true data. The device is then ready for the next operation. See Figure 11 for Data# Polling timing waveforms. In order for Data# Polling to function correctly, the byte being polled must be erased prior to programming.



4 Megabit SuperFlash EEPROM SST28SF040 / SST28LF040 / SST28VF040

Toggle Bit (DQ₆)

An alternative means for determining the Write operation status is by monitoring the Toggle Bit, DQ₆. During a Write operation, consecutive attempts to read data from the device will result in DQ₆ toggling between logic 0 (low) and logic 1 (high). When the write cycle is completed, the toggling will stop. The device is then ready for the next operation. See Figure 12 for Toggle Bit timing waveforms.

Successive Reads

An Alternative means for determining an end of a write cycle is by reading the same address for two consecutive data matches.

Product Identification

The Product Identification mode identifies the device as SST28SF040/28LF040/28VF040 and the manufacturer as SST. This mode may be accessed by hardware and software operations. The hardware operation is typically used by an external programmer to identify the correct algorithm for the SST28SF040/28LF040/28VF040. Users may wish to use the software operation to identify the device (i.e., using the device code). For details see Table 2 for the hardware operation and Figure 18 for the software operation. The manufacturer and device codes are the same for both operations.

PRODUCT IDENTIFICATION TABLE

	Byte	Data
Manufacturer's Code	0000 H	BF H
Device Code	0001 H	04 H

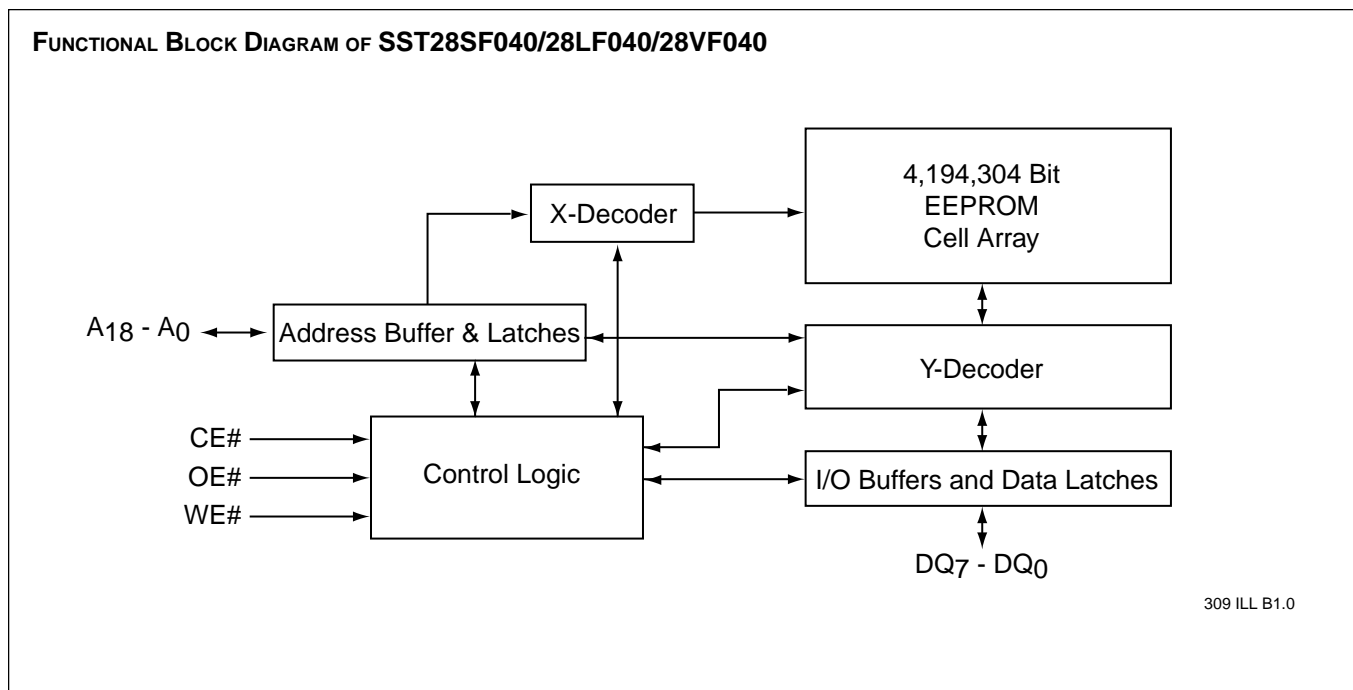



4 Megabit SuperFlash EEPROM SST28SF040 / SST28LF040 / SST28VF040

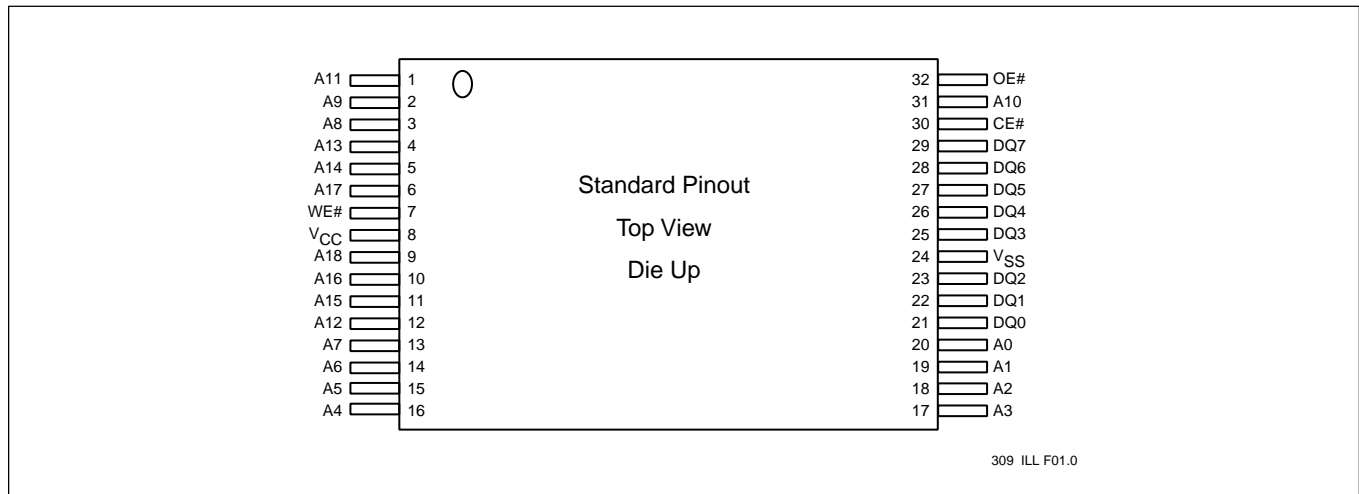

FIGURE 1: STANDARD PIN ASSIGNMENT FOR 32-PIN TSOP PACKAGE

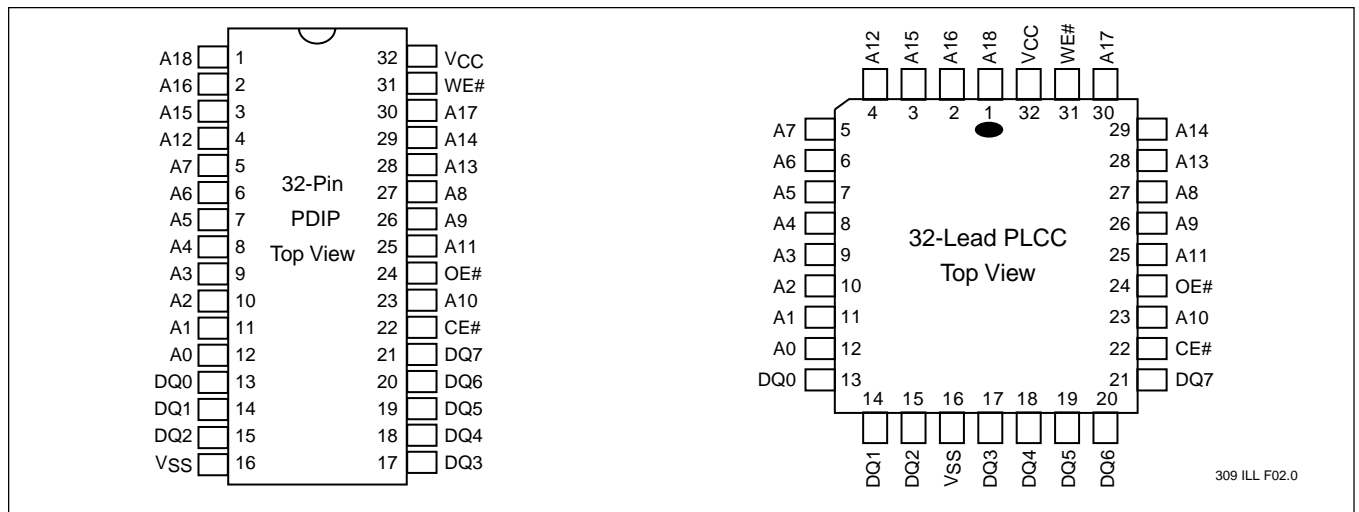

FIGURE 2: PIN ASSIGNMENTS FOR 32-PIN PLASTIC DIP'S AND 32-PIN PLCC'S

TABLE 1: PIN DESCRIPTION

Symbol	Pin Name	Functions
A ₁₈ -A ₈	Row Address Inputs	To provide memory addresses. Row addresses define a sector.
A ₇ -A ₀	Column Address Inputs	Selects the byte within the sector.
DQ ₇ -DQ ₀	Data Input/Output	To output data during read cycles and receive input data during write cycles. Data is internally latched during a write cycle. The outputs are in tri-state when OE#, CE # is high.
CE#	Chip Enable	To activate the device when CE # is low. ⁽¹⁾
OE#	Output Enable	To gate the data output buffers. ⁽¹⁾
WE#	Write Enable	To control the write operations. ⁽¹⁾
V _{cc}	Power Supply	To provide 5-volt supply ($\pm 10\%$) for the SST28SF040, 3.0-3.6V supply for the SST28LF040 and 2.7-3.6V supply for the SST28VF040
V _{ss}	Ground	

Note: ⁽¹⁾ This pin is considered an input for the purposes of the DC Operation Characteristics Table.

309 PGM T1.1



4 Megabit SuperFlash EEPROM SST28SF040 / SST28LF040 / SST28VF040

TABLE 2: OPERATION MODES SELECTION

Mode	CE#	OE#	WE#	DQ	Address
Read	V _{IL}	V _{IL}	V _{IH}	D _{OUT}	A _{IN}
Byte Program	V _{IL}	V _{IH}	V _{IL}	D _{IN}	A _{IN} , See Table 3
Sector Erase	V _{IL}	V _{IH}	V _{IL}	D _{IN}	A _{IN} , See Table 3
Standby	V _{IH}	X	X	High Z	X
Write Inhibit	X	V _{IL}	X	High Z/ D _{OUT}	X
Write Inhibit	X	X	V _{IH}	High Z/ D _{OUT}	X
Software Chip Erase	V _{IL}	V _{IH}	V _{IL}	D _{IN}	See Table 3
Product Identification					
Hardware Mode	V _{IL}	V _{IL}	V _{IH}	Manufacturer Code (BF) Device Code (04)	A ₁₈ -A ₁ =V _{IL} , A ₉ =V _H , A ₀ =V _{IL} A ₁₈ -A ₁ =V _{IL} , A ₉ =V _H , A ₀ =V _{IH}
Software Mode	V _{IL}	V _{IL}	V _{IH}		See Table 3
SDP Enable & Disable Mode	V _{IL}	V _{IL}	V _{IH}		See Table 3
Reset	V _{IL}	V _{IH}	V _{IL}		See Table 3

309 PGM T2.0

TABLE 3: SOFTWARE COMMAND SUMMARY

Command Summary	Required	Setup Command Cycle			Execute Command Cycle			SDP ⁽⁵⁾
	Cycle(s)	Type ⁽¹⁾	Addr ^(2,3)	Data ⁽⁴⁾	Type ⁽¹⁾	Addr ^(2,3)	Data ⁽⁴⁾	
Sector Erase	2	W	X	20H	W	SA	D0H	N
Byte Program	2	W	X	10H	W	PA	PD	N
Chip Erase	2	W	X	30H	W	X	30H	N
Reset	1	W	X	FFH				Y
Read ID	2	W	X	90H	R	(8)	(8)	Y
Software Data Protect	7	R	(6)					
Software Data Unprotect	7	R	(7)					

309 PGM T3.1

Notes:

1. Type definition: W = Write, R = Read, X= don't care
2. Addr (Address) definition: SA = Sector Address = A₁₈ - A₈, sector size = 256 bytes; A₇- A₀ = X for this command.
3. Addr (Address) definition: PA = Program Address = A₁₈ - A₀.
4. Data definition: PD = Program Data, H = number in hex.
5. SDP = Software Data Protect mode using 7 Read Cycle Sequence.
 - a) Y = the operation can be executed with protection enabled
 - b) N = the operation cannot be executed with protection enabled
6. Refer to Figure 10 for the 7 Read Cycle sequence for Software Data Protect.
7. Refer to Figure 9 for the 7 Read Cycle sequence for Software Data Unprotect.
8. Address 0000H retrieves the manufacturer' code of BFH and address 0001H retrieves the device code of 04H.

TABLE 4: MEMORY ARRAY DETAIL

Sector Select	Byte Select
A ₁₈ - A ₈	A ₇ - A ₀

310 PGM T4.0



4 Megabit SuperFlash EEPROM

SST28SF040 / SST28LF040 / SST28VF040

Absolute Maximum Stress Ratings (Applied conditions greater than those listed under “Absolute Maximum Stress Ratings” may cause permanent damage to the device. This is a stress rating only and functional operation of the device at these conditions or conditions greater than those defined in the operational sections of this data sheet is not implied. Exposure to absolute maximum stress rating conditions may affect device reliability.)

Temperature Under Bias	-55°C to +125°C
Storage Temperature	-65°C to +150°C
D. C. Voltage on Any Pin to Ground Potential	-0.5V to V _{CC} + 0.5V
Transient Voltage (<20 ns) on Any Pin to Ground Potential	-1.0V to V _{CC} + 1.0V
Voltage on A ₉ Pin to Ground Potential	-0.5V to 14.0V
Package Power Dissipation Capability (Ta = 25°C)	1.0W
Through Hole Soldering Temperature (10 Seconds)	300°C
Surface Mount Lead Soldering Temperature (3 Seconds)	240°C
Output Short Circuit Current ⁽¹⁾	100 mA

Note: ⁽¹⁾ Outputs shorted for no more than one second. No more than one output shorted at a time.

SST28SF040 OPERATING RANGE

Range	Ambient Temp	V _{CC}
Commercial	0°C to +70°C	5V±10%
Industrial	-40°C to +85°C	5V±10%

AC CONDITIONS OF TEST

Input Rise/Fall Time	10 ns
Output Load	1 TTL Gate and C _L = 100 pF
See Figures 13 and 14	

SST28LF040 OPERATING RANGE

Range	Ambient Temp	V _{CC}
Commercial	0°C to +70°C	3.0 to 3.6V
Industrial	-40°C to +85°C	3.0 to 3.6V

SST28VF040 OPERATING RANGE

Range	Ambient Temp	V _{CC}
Commercial	0°C to +70°C	2.7 to 3.6V
Industrial	-40°C to +85°C	2.7 to 3.6V



4 Megabit SuperFlash EEPROM SST28SF040 / SST28LF040 / SST28VF040

TABLE 5: SST28SF040 DC OPERATING CHARACTERISTICS

Symbol	Parameter	Limits			Test Conditions
		Min	Max	Units	
I _{CC}	Power Supply Current				CE# = OE# = V _{IL} , WE# = V _{IH} , all I/Os open
	Read		25	mA	Address input = V _{IL} /V _{IH} , at f=1/T _{RC} Min. V _{CC} = V _{CC} Max
	Program and Erase		40	mA	CE# = WE# = V _{IL} , OE# = V _{IH} V _{CC} = V _{CC} Max.
ISB1	Standby V _{CC} Current (TTL input)		3	mA	CE# = V _{IH} , V _{CC} = V _{CC} Max.
ISB2	Standby V _{CC} Current (CMOS input)		20	μA	CE# = V _{CC} - 0.3V, V _{CC} = V _{CC} Max
I _{LI}	Input Leakage Current		1	μA	V _{IN} = GND to V _{CC} , V _{CC} = V _{CC} Max.
I _{LO}	Output Leakage Current		10	μA	V _{OUT} = GND to V _{CC} , V _{CC} = V _{CC} Max.
V _{IL}	Input Low Voltage		0.8	V	V _{CC} = V _{CC} Min.
V _{IH}	Input High Voltage	2.0		V	V _{CC} = V _{CC} Max.
V _{OL}	Output Low Voltage		0.4	V	I _{OL} = 2.1 mA, V _{CC} = V _{CC} Min.
V _{OH}	Output High Voltage	2.4		V	I _{OH} = -400 μA, V _{CC} = V _{CC} Min.
V _H	Supervoltage for A ₉	11.6	12.4	V	CE# = OE# = V _{IL} , WE# = V _{IH}
I _H	Supervoltage Current for A ₉		200	μA	CE# = OE# = V _{IL} , WE# = V _{IH} , A ₉ = V _H Max.

309 PGM T5.1

TABLE 6: SST28LF040/28VF040 DC OPERATING CHARACTERISTICS

Symbol	Parameter	Limits			Test Conditions
		Min	Max	Units	
I _{CC}	Power Supply Current				CE# = OE# = V _{IL} , WE# = V _{IH} , all I/Os open
	Read		10	mA	Address input = V _{IL} /V _{IH} , at f=1/T _{RC} Min. V _{CC} = V _{CC} Max
	Program and Erase		25	mA	CE# = WE# = V _{IL} , OE# = V _{IH} V _{CC} = V _{CC} Max.
ISB1	Standby V _{CC} Current (TTL input)		1	mA	CE# = V _{IH} , V _{CC} = V _{CC} Max.
ISB2	Standby V _{CC} Current (CMOS input)		20	μA	CE# = V _{CC} - 0.3V, V _{CC} = V _{CC} Max
I _{LI}	Input Leakage Current		1	μA	V _{IN} = GND to V _{CC} , V _{CC} = V _{CC} Max.
I _{LO}	Output Leakage Current		10	μA	V _{OUT} = GND to V _{CC} , V _{CC} = V _{CC} Max.
V _{IL}	Input Low Voltage		0.8	V	V _{CC} = V _{CC} Min.
V _{IH}	Input High Voltage	2.0		V	V _{CC} = V _{CC} Max.
V _{OL}	Output Low Voltage		0.4	V	I _{OL} = 100 μA, V _{CC} = V _{CC} Min.
V _{OH}	Output High Voltage	2.4		V	I _{OH} = -100 μA, V _{CC} = V _{CC} Min.
V _H	Supervoltage for A ₉	11.6	12.4	V	CE# = OE# = V _{IL} , WE# = V _{IH}
I _H	Supervoltage Current for A ₉		200	μA	CE# = OE# = V _{IL} , WE# = V _{IH} , A ₉ = V _H Max.

309 PGM T6.1



4 Megabit SuperFlash EEPROM

SST28SF040 / SST28LF040 / SST28VF040

TABLE 7: RECOMMENDED SYSTEM POWER-UP TIMINGS

Symbol	Parameter	Minimum	Units
T _{PU-READ} ⁽¹⁾	Power-up to Read Operation	200	μs
T _{PU-WRITE} ⁽¹⁾	Power-up to Write Operation	200	μs

309 PGM T7.1

TABLE 8: CAPACITANCE (T_a = 25 °C, f=1 MHz, other pins open)

Parameter	Description	Test Condition	Maximum
C _{I/O} ⁽¹⁾	I/O Pin Capacitance	V _{I/O} = 0V	12 pF
C _{IN} ⁽¹⁾	Input Capacitance	V _{IN} = 0V	6 pF

309 PGM T8.0

Note: ⁽¹⁾This parameter is measured only for initial qualification and after a design or process change that could affect this parameter.

TABLE 9: RELIABILITY CHARACTERISTICS

Symbol	Parameter	Minimum Specification	Units	Test Method
N _{END}	Endurance	1,000 & 10,000 ⁽²⁾	Cycles	JEDEC Standard A117
T _{DR} ⁽¹⁾	Data Retention	100	Years	JEDEC Standard A103
V _{ZAP_HBM} ⁽¹⁾	ESD Susceptibility Human Body Model	2000	Volts	JEDEC Standard A114
V _{ZAP_MM} ⁽¹⁾	ESD Susceptibility Machine Model	200	Volts	JEDEC Standard A115
I _{LTH} ⁽¹⁾	Latch Up	100	mA	JEDEC Standard 78

309 PGM T9.1

Note: ⁽¹⁾ This parameter is measured only for initial qualification and after a design or process change that could affect this parameter.

⁽²⁾ See Ordering Information for desired type.



4 Megabit SuperFlash EEPROM SST28SF040 / SST28LF040 / SST28VF040

AC CHARACTERISTICS

TABLE 10: SST28SF040 READ CYCLE TIMING PARAMETERS

IEEE Symbol	Industry Symbol	Parameter	SST28SF040-120		SST28SF040-150		Units
			Min	Max	Min	Max	
tAVAV	T _{RC}	Read Cycle Time	120		150		ns
tAVQV	T _{AA}	Address Access Time		120		150	ns
tELQV	T _{CE}	Chip Enable Access Time		120		150	ns
tGLQV	T _{OE}	Output Enable Access Time		50		70	ns
tEHQZ	T _{CLZ} ⁽¹⁾	CE# Low to Active Output	0		0		ns
tGHQZ	T _{OLZ} ⁽¹⁾	OE# Low to Active Output	0		0		ns
tELQX	T _{CHZ} ⁽¹⁾	CE# High to High-Z Output		30		40	ns
tGLQX	T _{OHZ} ⁽¹⁾	OE# High to High-Z Output		30		40	ns
tAXQX	T _{OH} ⁽¹⁾	Output Hold from Address Change	0		0		ns

309 PGM T10.0

TABLE 11: SST28LF040 READ CYCLE TIMING PARAMETERS

IEEE Symbol	Industry Symbol	Parameter	SST28LF040-200		SST28LF040-250		Units
			Min	Max	Min	Max	
tAVAV	T _{RC}	Read Cycle time	200		250		ns
tAVQV	T _{AA}	Address Access Time		200		250	ns
tELQV	T _{CE}	Chip Enable Access Time		200		250	ns
tGLQV	T _{OE}	Output Enable Access Time		120		120	ns
tEHQZ	T _{CLZ} ⁽¹⁾	CE# Low to Active Output	0		0		ns
tGHQZ	T _{OLZ} ⁽¹⁾	OE# Low to Active Output	0		0		ns
tELQX	T _{CHZ} ⁽¹⁾	CE# High to High-Z Output		60		60	ns
tGLQX	T _{OHZ} ⁽¹⁾	OE# High to High-Z Output		60		60	ns
tAXQX	T _{OH} ⁽¹⁾	Output Hold from Address Change	0		0		ns

309 PGM T11.0

TABLE 12: SST28VF040 READ CYCLE TIMING PARAMETERS

IEEE Symbol	Industry Symbol	Parameter	SST28VF040-250		SST28VF040-300		Units
			Min	Max	Min	Max	
tAVAV	T _{RC}	Read Cycle time	250		300		ns
tAVQV	T _{AA}	Address Access Time		250		300	ns
tELQV	T _{CE}	Chip Enable Access Time		250		300	ns
tGLQV	T _{OE}	Output Enable Access Time		120		150	ns
tEHQZ	T _{CLZ} ⁽¹⁾	CE# Low to Active Output	0		0		ns
tGHQZ	T _{OLZ} ⁽¹⁾	OE# Low to Active Output	0		0		ns
tELQX	T _{CHZ} ⁽¹⁾	CE# High to High-Z Output		60		60	ns
tGLQX	T _{OHZ} ⁽¹⁾	OE# High to High-Z Output		60		60	ns
tAXQX	T _{OH} ⁽¹⁾	Output Hold from Address Change	0		0		ns

309 PGM T12.0



4 Megabit SuperFlash EEPROM

SST28SF040 / SST28LF040 / SST28VF040

TABLE 13: SST28SF040 ERASE/PROGRAM CYCLE TIMING PARAMETERS

IEEE Symbol	Industry Symbol	Parameter	Min	Max	Units
tAVA	T _{BP}	Byte Program Cycle Time		40	μs
tWLWH	T _{WP}	Write Pulse Width (WE#)	100		ns
tAVWL	T _{AS}	Address Setup Time	10		ns
tWLAX	T _{AH}	Address Hold Time	50		ns
tELWL	T _{CS}	CE# Setup Time	0		ns
tWHEX	T _{CH}	CE# Hold Time	0		ns
tGHWL	T _{OES}	OE# High Setup Time	10		ns
tWGL	T _{OEH}	OE# High Hold Time	10		ns
tWLEH	T _{CP}	Write Pulse Width (CE#)	100		ns
tDVWH	T _{DS}	Data Setup Time	50		ns
tWHDX	T _{DH}	Data Hold Time	10		ns
tWHWL2	T _{SE}	Sector Erase Cycle Time		4	ms
	T _{RST} ⁽¹⁾	Reset Command Recovery Time		4	μs
tWHWL3	T _{SCE}	Software Chip Erase Cycle Time		20	ms
tEHEL	T _{CPH}	CE# High Pulse Width	50		ns
tWHWL1	T _{WPH}	WE# High Pulse Width	50		ns
	T _{PCP} ⁽¹⁾	Protect Chip Enable Pulse Width	50		ns
	T _{PCH} ⁽¹⁾	Protect Chip Enable High Time	50		ns
	T _{PAS} ⁽¹⁾	Protect Address Setup Time	0		ns
	T _{PAH} ⁽¹⁾	Protect Address Hold Time	50		ns

309 PGM T13.1

Note: ⁽¹⁾This parameter is measured only for initial qualification and after the design or process change that could affect this parameter.



4 Megabit SuperFlash EEPROM SST28SF040 / SST28LF040 / SST28VF040

TABLE 14: SST28LF040/28VF040 ERASE/PROGRAM CYCLE TIMING PARAMETERS

IEEE Symbol	Industry Symbol	Parameter	Min	Max	Units
tAVA	T _{BP}	Byte Program Cycle Time		40	μs
tWLWH	T _{WP}	Write Pulse Width (WE#)	200		ns
tAVWL	T _{AS}	Address Setup Time	10		ns
tWLAX	T _{AH}	Address Hold Time	100		ns
tELWL	T _{CS}	CE# Setup Time	0		ns
tWHEX	T _{CH}	CE# Hold Time	0		ns
tGHWL	T _{OES}	OE# High Setup Time	20		ns
tWGL	T _{OEH}	OE# High Hold Time	20		ns
tWLEH	T _{CP}	Write Pulse Width (CE#)	200		ns
tDVWH	T _{DS}	Data Setup Time	100		ns
tWHDX	T _{DH}	Data Hold Time	20		ns
tWHWL2	T _{SE}	Sector Erase Cycle Time		4	ms
	T _{RST} ⁽¹⁾	Reset Command Recovery Time		4	μs
tWHWL3	T _{SCE}	Software Chip Erase Cycle Time		20	ms
tEHEL	T _{CPH}	CE# High Pulse Width	50		ns
tWHWL1	T _{WPH}	WE# High Pulse Width	50		ns
	T _{PCP} ⁽¹⁾	Protect Chip Enable Pulse Width	20		ns
	T _{PCH} ⁽¹⁾	Protect Chip Enable High Time	20		ns
	T _{PAS} ⁽¹⁾	Protect Address Setup Time	0		ns
	T _{PAH} ⁽¹⁾	Protect Address Hold Time	100		ns

309 PGM T14.0

Note: ⁽¹⁾This parameter is measured only for initial qualification and after the design or process change that could affect this parameter.



4 Megabit SuperFlash EEPROM

SST28SF040 / SST28LF040 / SST28VF040

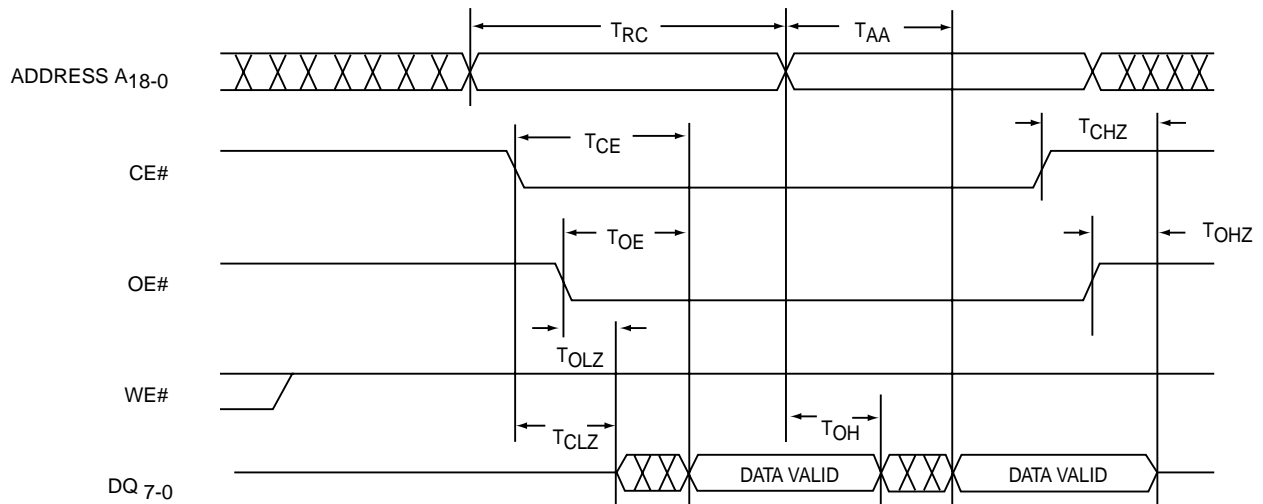

309 ILL F03.0

FIGURE 3: READ CYCLE TIMING DIAGRAM

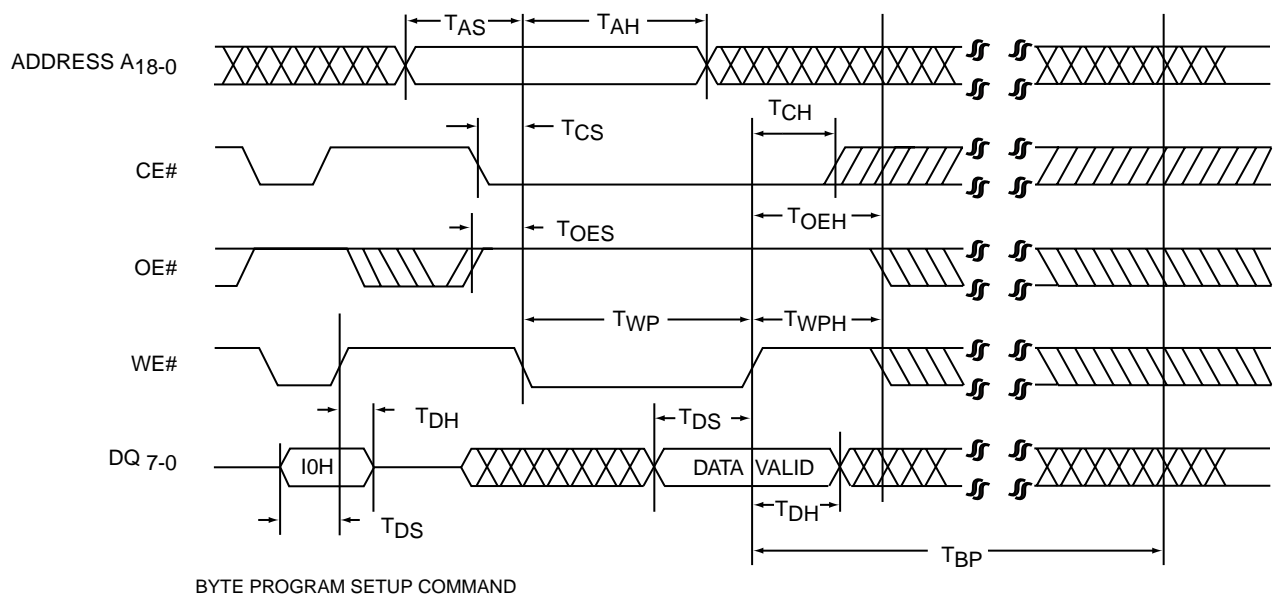

BYTE PROGRAM SETUP COMMAND

309 ILL F04.0

FIGURE 4: WE# CONTROLLED BYTE PROGRAM TIMING DIAGRAM



4 Megabit SuperFlash EEPROM SST28SF040 / SST28LF040 / SST28VF040

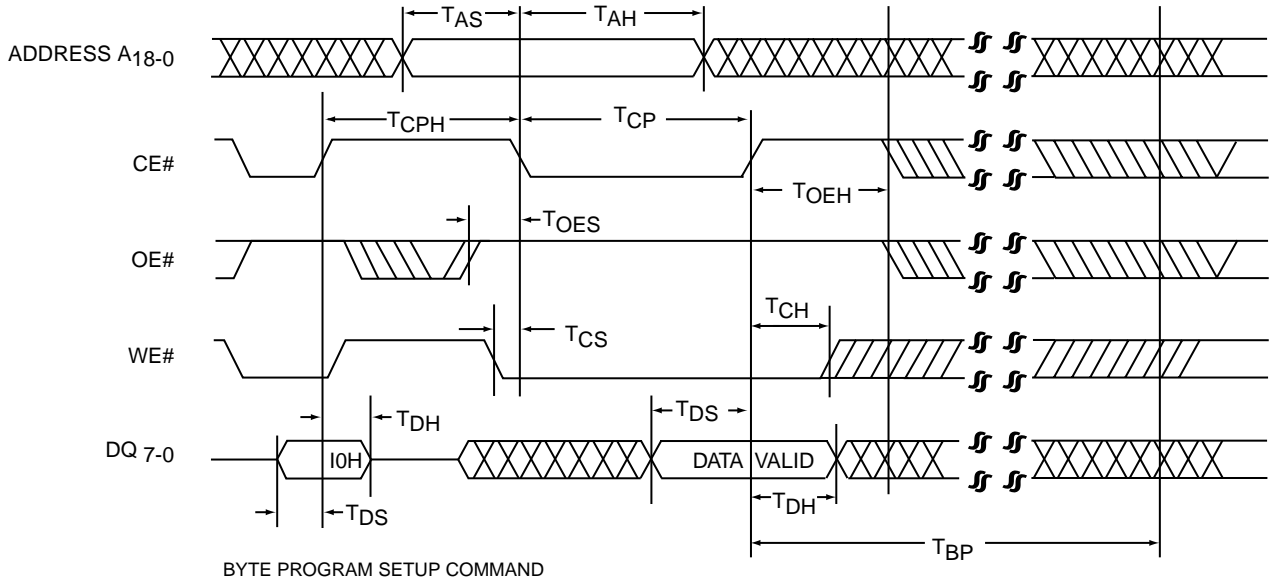

FIGURE 5: CE# CONTROLLED BYTE PROGRAM TIMING DIAGRAM

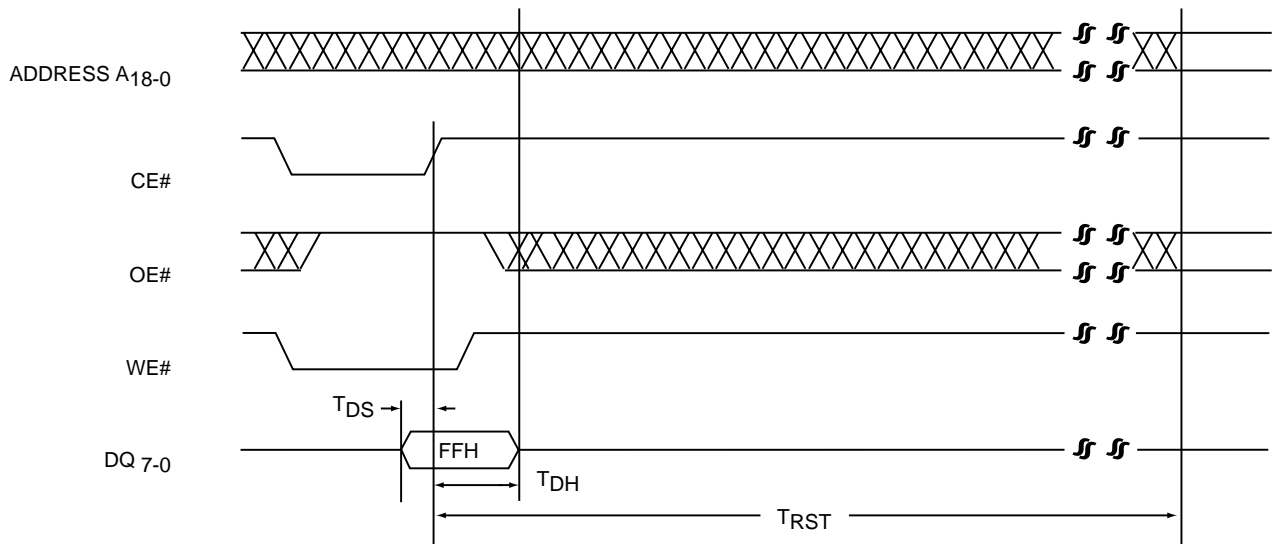
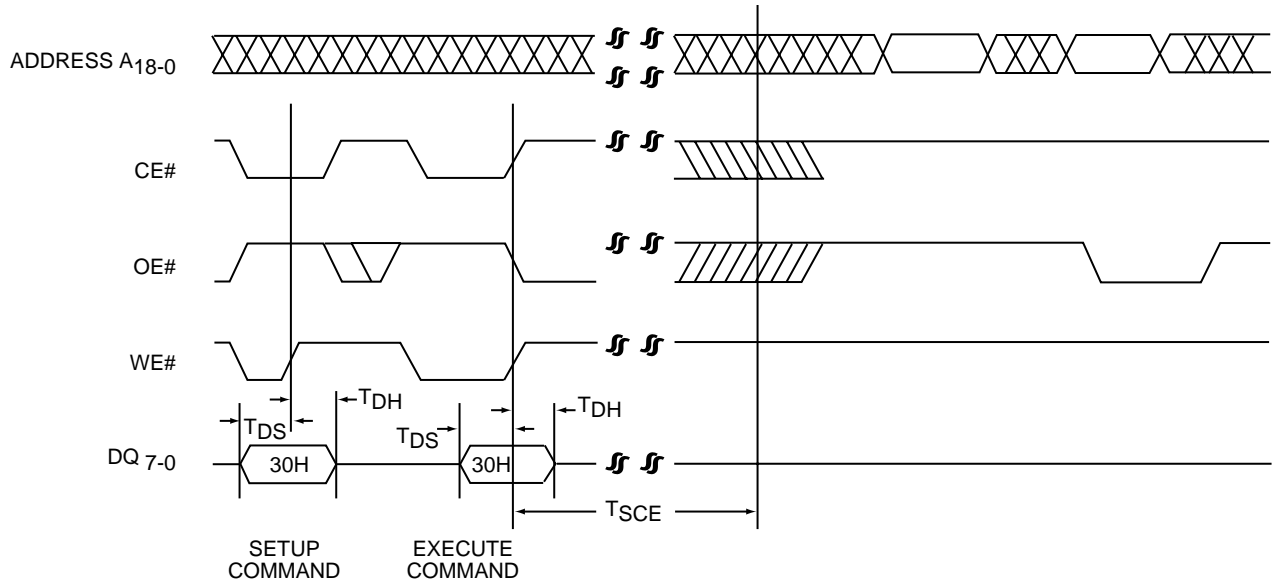

FIGURE 6: RESET COMMAND TIMING DIAGRAM



4 Megabit SuperFlash EEPROM SST28SF040 / SST28LF040 / SST28VF040



309 ILL F07.0

FIGURE 7: CHIP ERASE TIMING DIAGRAM

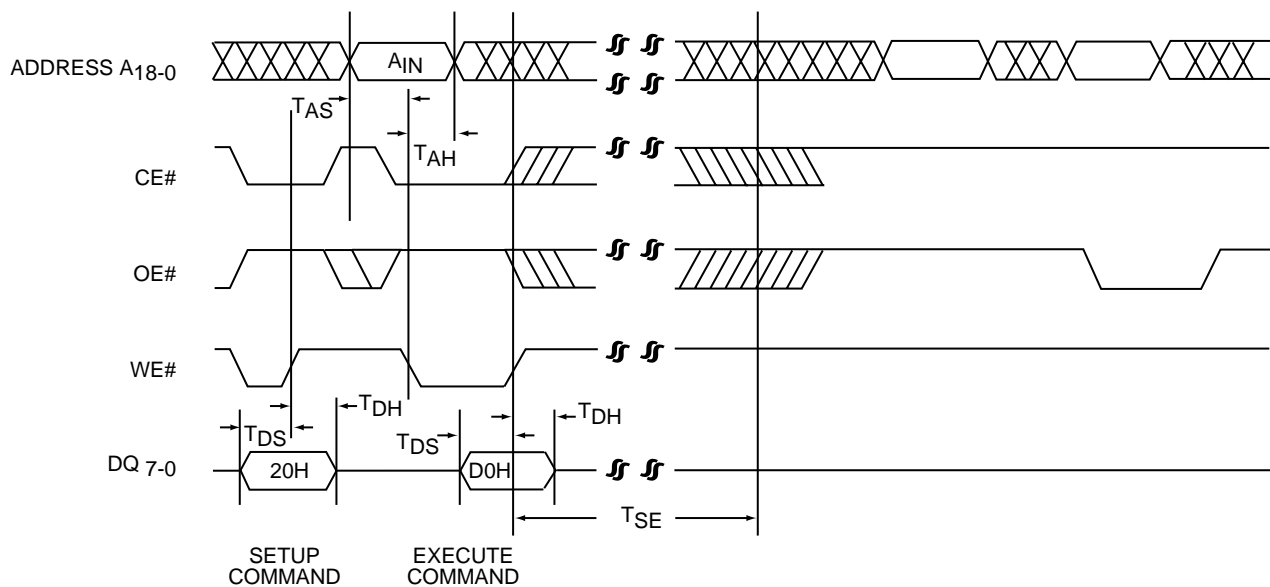

309 ILL F08.0

FIGURE 8: SECTOR ERASE TIMING DIAGRAM



4 Megabit SuperFlash EEPROM SST28SF040 / SST28LF040 / SST28VF040

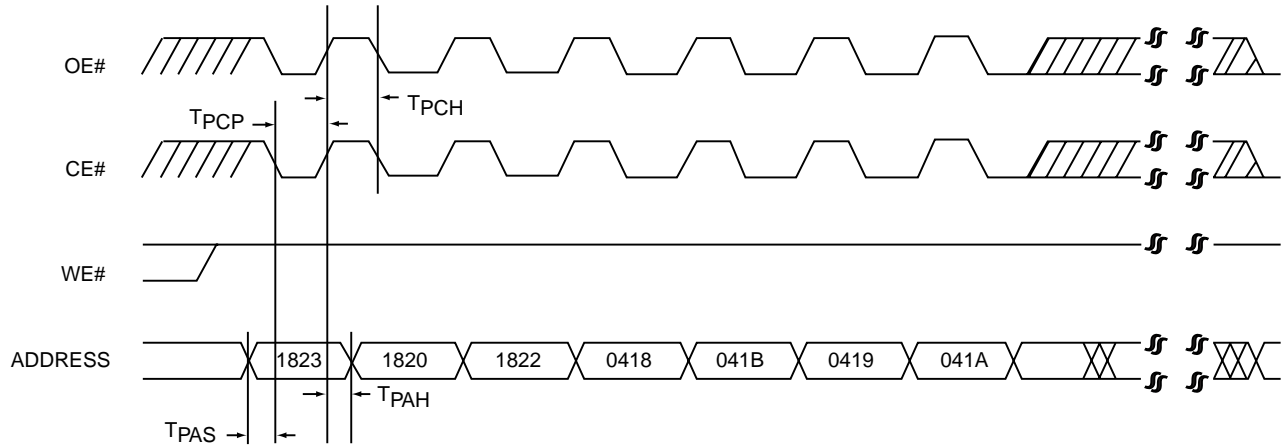

NOTE: A. ADDRESSES ARE LATCHED INTERNALLY ON THE RISING EDGE OF:

1. OE# IF CE# IS KEPT AT LOW ALL TIME.
2. CE# IF OE# IS KEPT AT LOW ALL TIME.
3. THE FIRST PIN TO GO HIGH IF BOTH ARE TOGGLED.

B. ABOVE ADDRESS VALUES ARE IN HEX.

C. ADDRESSES > A12 ARE "DON'T CARE"

309 ILL F09.1

FIGURE 9: SOFTWARE DATA UNPROTECT TIMING DIAGRAM

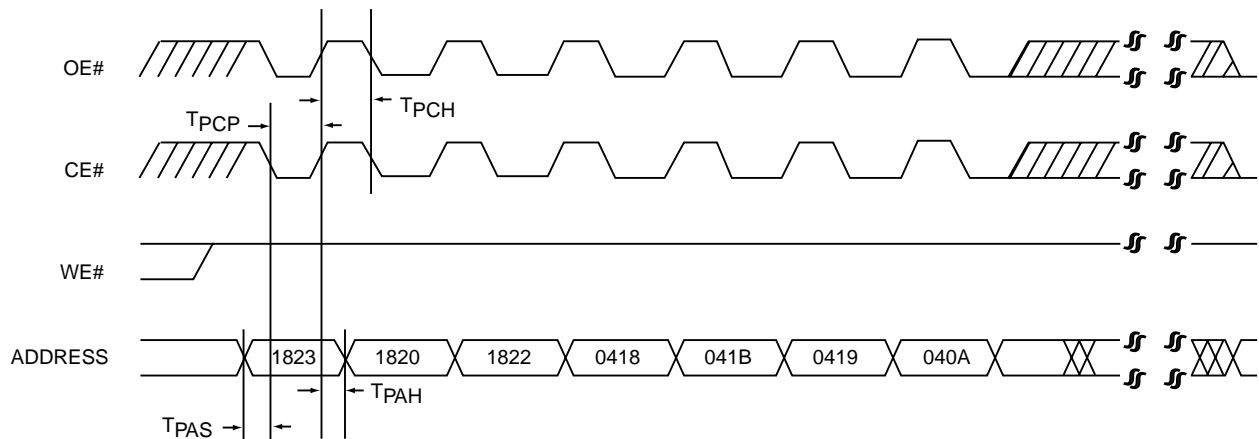

NOTE: A. ADDRESSES ARE LATCHED INTERNALLY ON THE RISING EDGE OF:

1. OE# IF CE# IS KEPT AT LOW ALL TIME.
2. CE# IF OE# IS KEPT AT LOW ALL TIME.
3. THE FIRST PIN TO GO HIGH IF BOTH ARE TOGGLED.

B. ABOVE ADDRESS VALUES ARE IN HEX.

C. ADDRESSES > A12 ARE "DON'T CARE"

309 ILL F10.0

FIGURE 10: SOFTWARE DATA PROTECT TIMING DIAGRAM



4 Megabit SuperFlash EEPROM SST28SF040 / SST28LF040 / SST28VF040

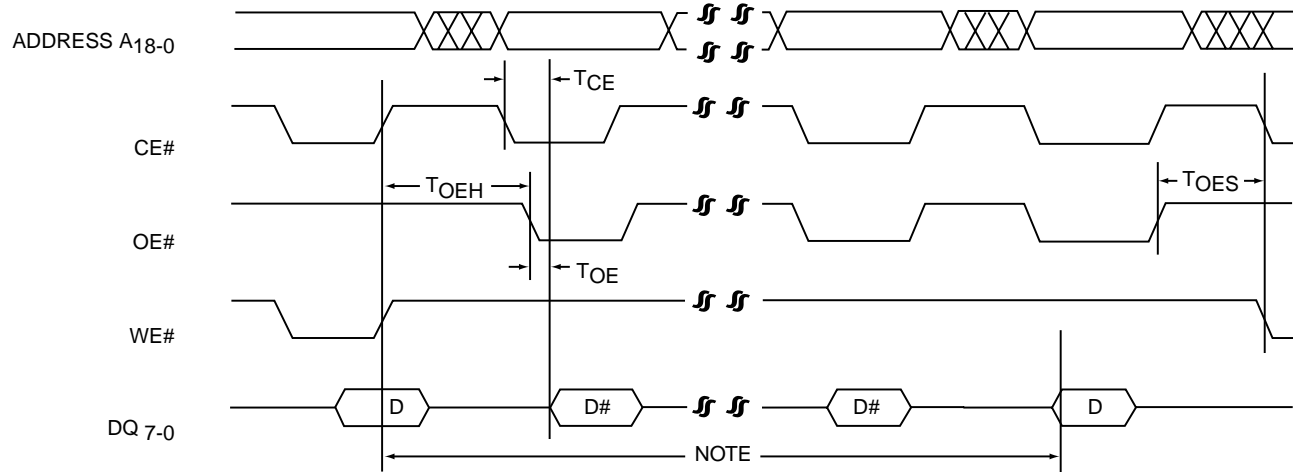

NOTE: THIS TIME INTERVAL SIGNAL CAN BE T_{SE} or T_{BP} DEPENDING UPON THE SELECTED OPERATION MODE.

309 ILL F11.0

FIGURE 11: DATA# POLLING TIMING DIAGRAM

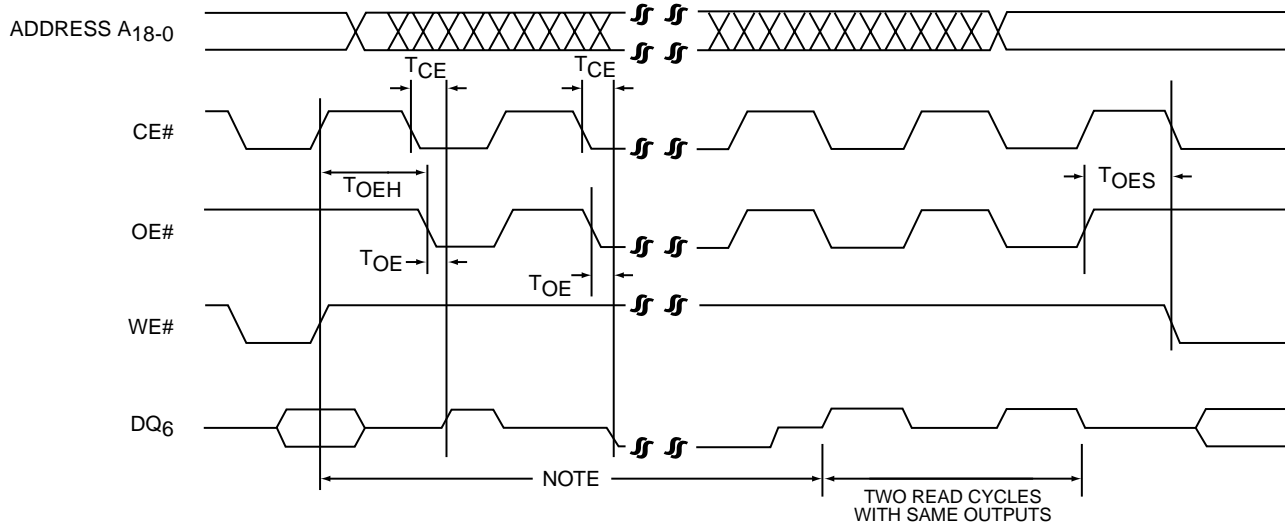

NOTE: THIS TIME INTERVAL SIGNAL CAN BE T_{SE} or T_{BP} DEPENDING UPON THE SELECTED OPERATION MODE.

309 ILL F12.0

FIGURE 12: TOGGLE BIT TIMING DIAGRAM



4 Megabit SuperFlash EEPROM SST28SF040 / SST28LF040 / SST28VF040

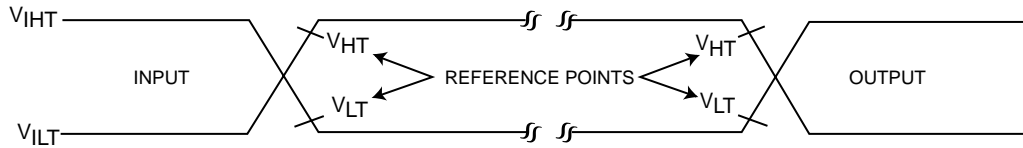

309 ILL F13.1

AC test inputs are driven at V_{IHT} (2.4 V) for a logic "1" and V_{ILT} (0.4 V) for a logic "0".
Measurement reference points for inputs and outputs are at V_{HT} (2.0 V) and V_{LT} (0.8 V)
Input rise and fall times (10% \leftrightarrow 90%) are <10 ns.

Note: V_{HT} - V_{HIGH} Test
 V_{LT} - V_{LOW} Test
 V_{IHT} - V_{INPUT} HIGH Test
 V_{ILT} - V_{INPUT} LOW Test

FIGURE 13: AC INPUT/OUTPUT REFERENCE WAVEFORM

TEST LOAD EXAMPLE

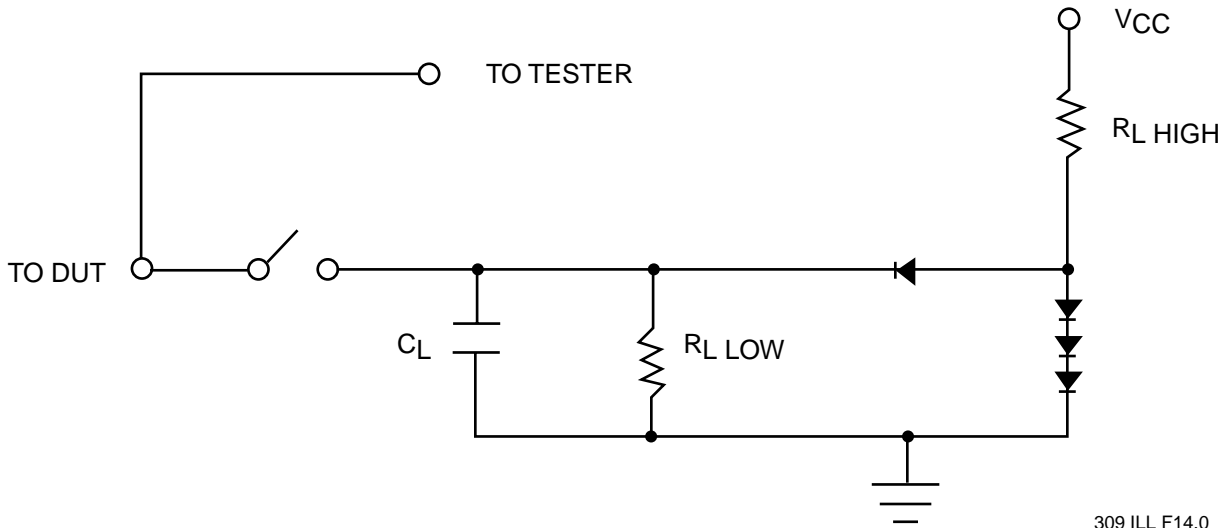

309 ILL F14.0

FIGURE 14: A TEST LOAD EXAMPLE



4 Megabit SuperFlash EEPROM SST28SF040 / SST28LF040 / SST28VF040

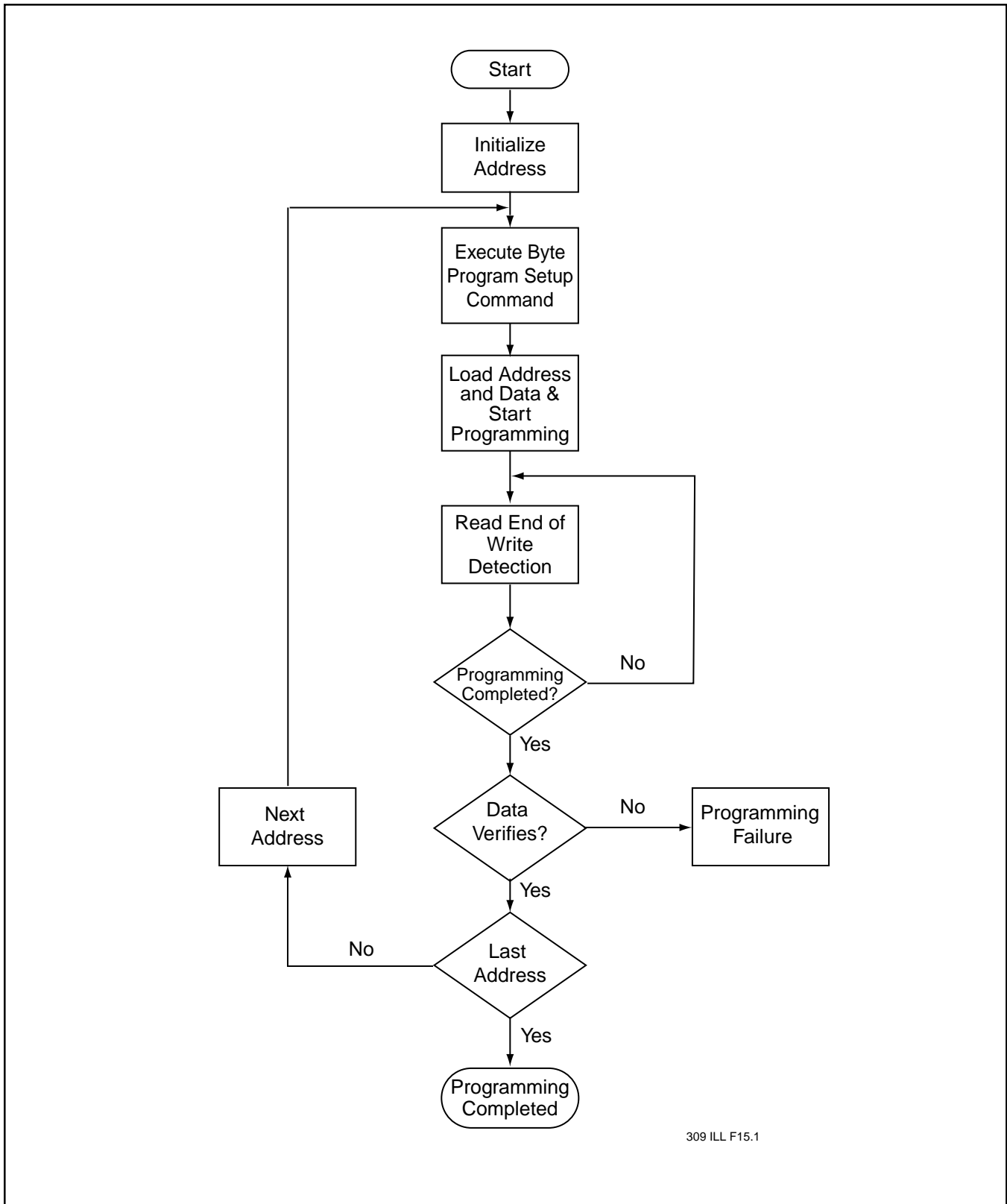

309 ILL F15.1

FIGURE 15: BYTE PROGRAM FLOWCHART

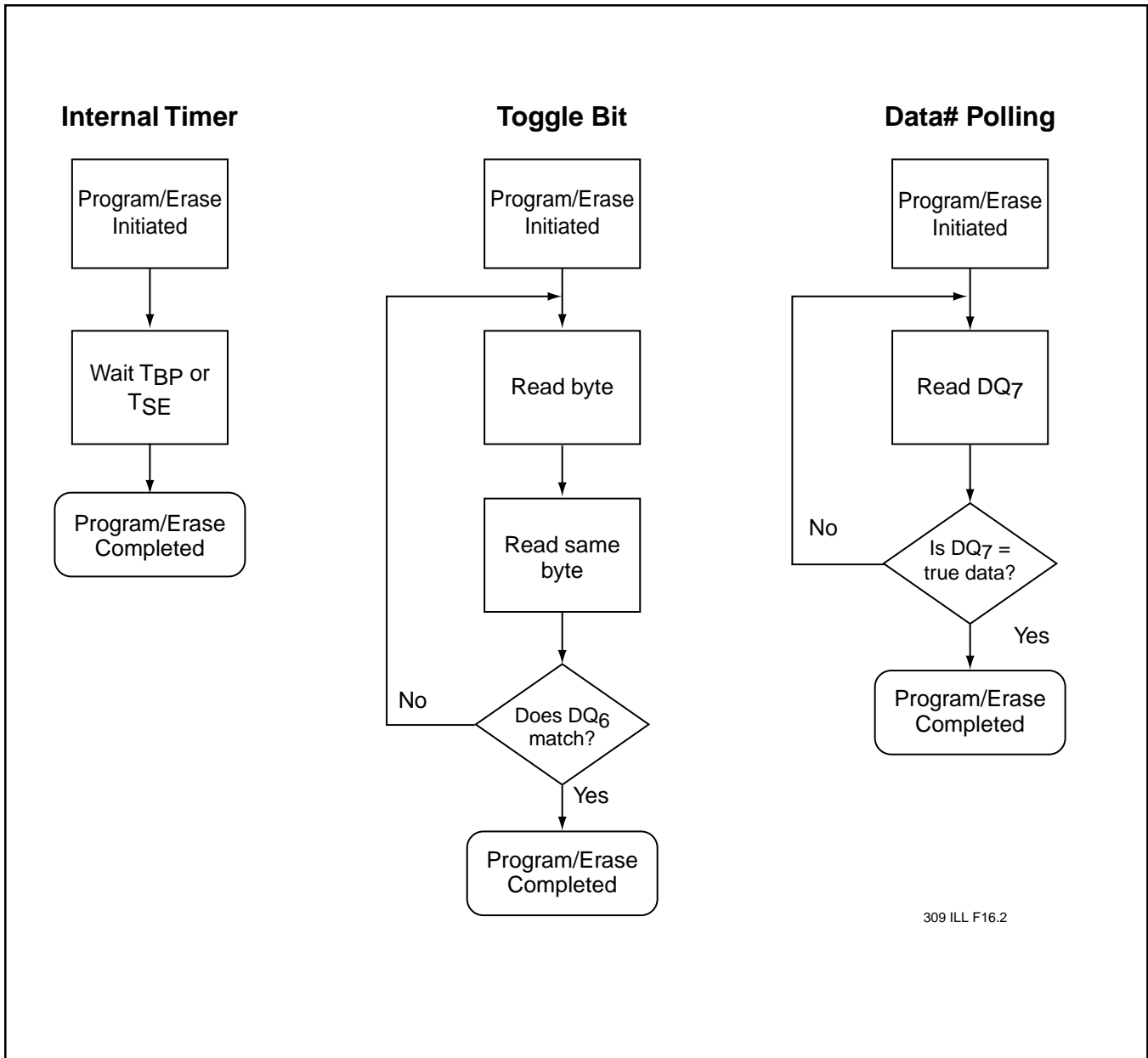
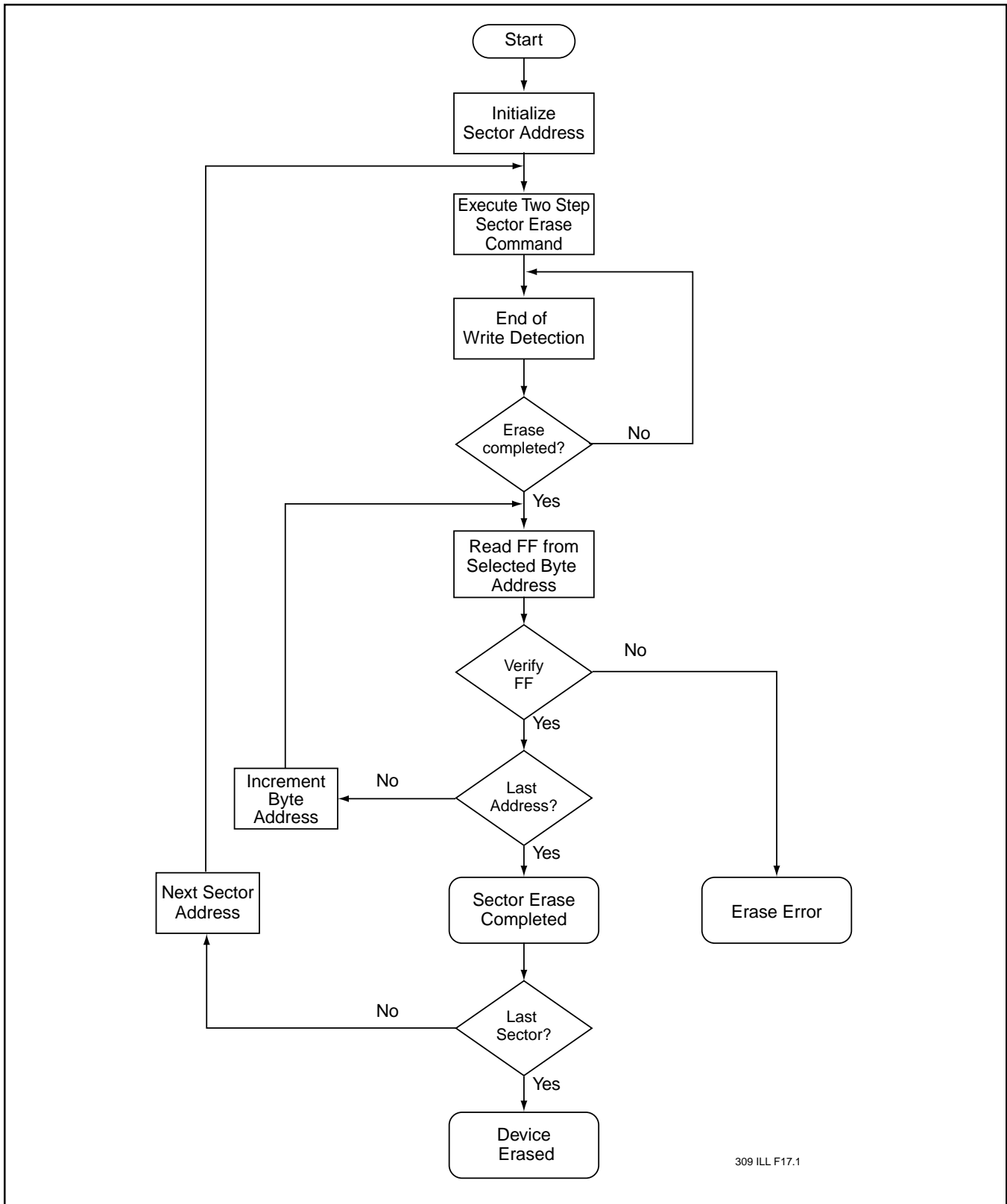
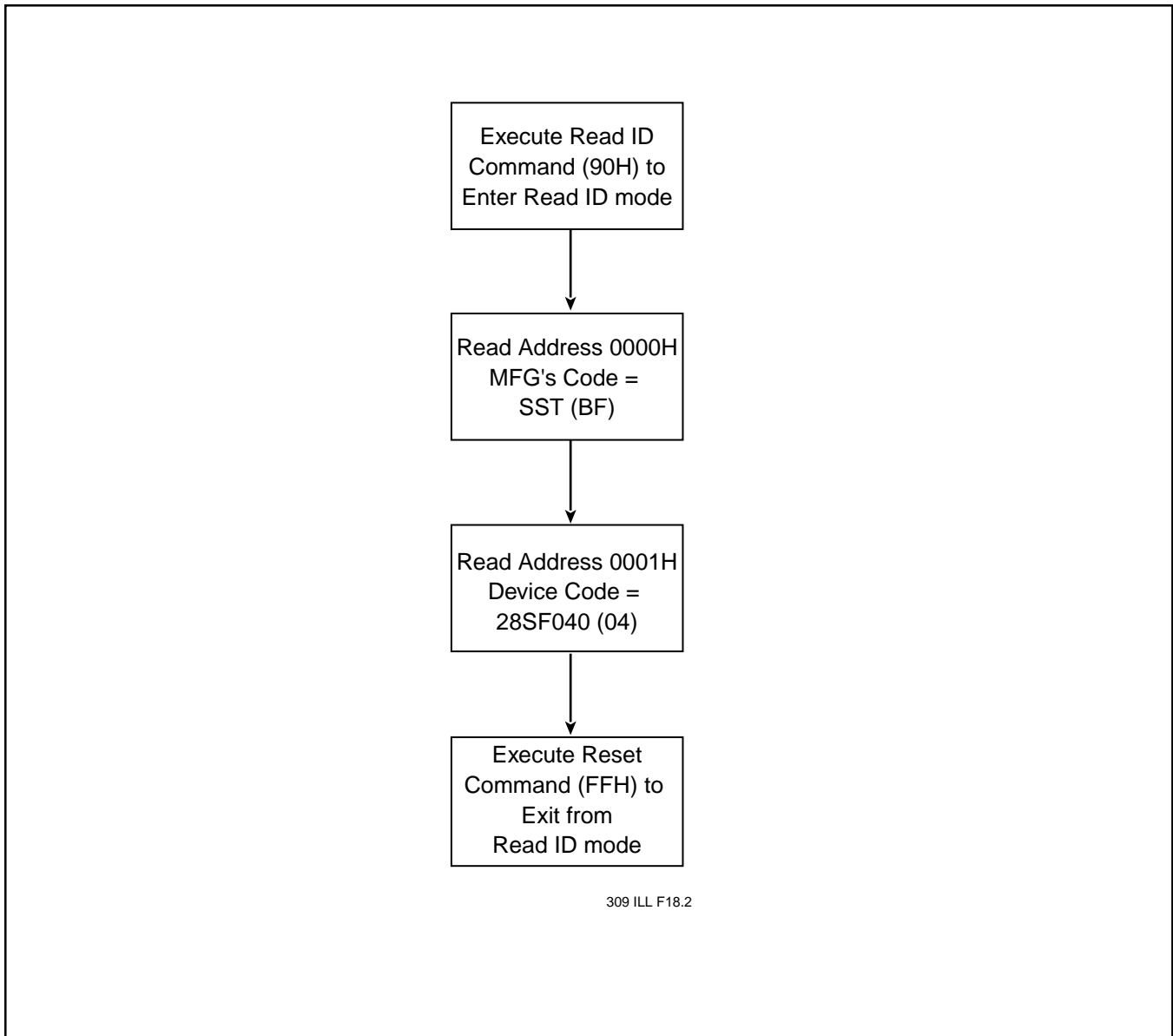

FIGURE 16: WRITE WAIT OPTIONS



309 ILL F17.1

FIGURE 17: SECTOR ERASE FLOWCHART



309 ILL F18.2

FIGURE 18: SOFTWARE PRODUCT ID FLOW



4 Megabit SuperFlash EEPROM SST28SF040 / SST28LF040 / SST28VF040

PRODUCT ORDERING INFORMATION

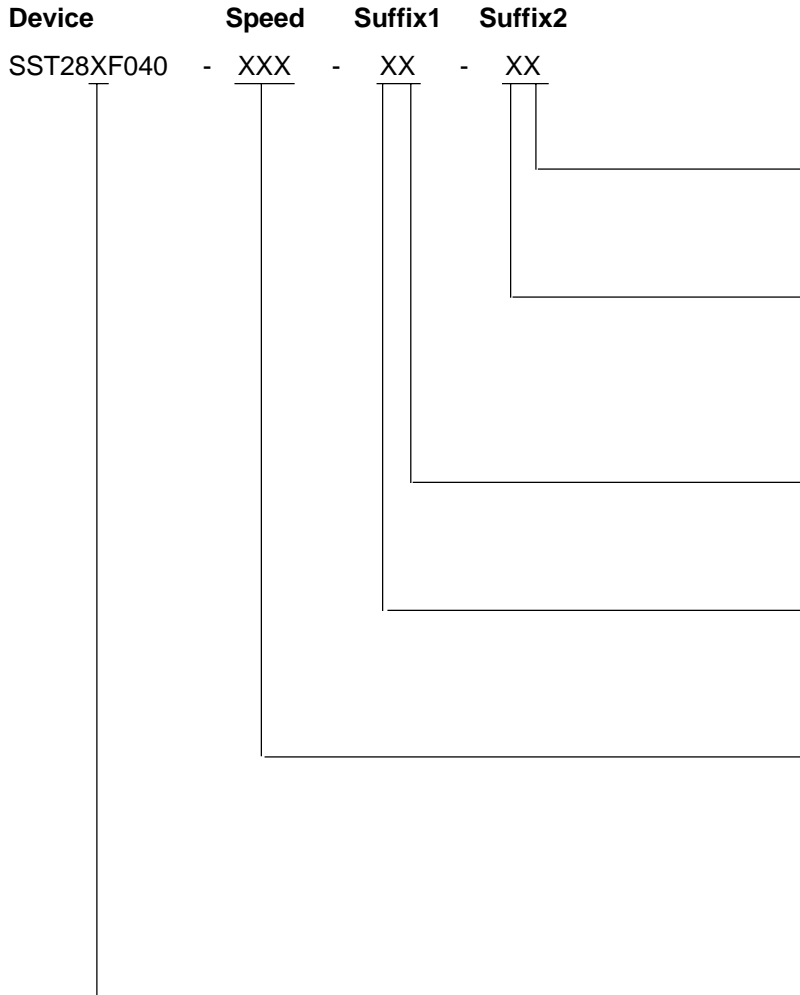

Package Modifier

H = 32 leads
Numeric = Die modifier

Package Type

P = PDIP
N = PLCC
E = TSOP (die up)
U = Unencapsulated die

Operating Temperature

C = Commercial = 0° to 70°C
I = Industrial = -40° to 85°C

Minimum Endurance

3 = 1000 cycles
4 = 10,000 cycles

Read Access Speed

300 = 300 ns
250 = 250 ns
200 = 200 ns
150 = 150 ns
120 = 120 ns

Voltage

S = 5V-only
L = 3.0-3.6V
V = 2.7-3.6V



4 Megabit SuperFlash EEPROM SST28SF040 / SST28LF040 / SST28VF040

SST28SF040 Valid combinations

SST28SF040-120-4C- EH SST28SF040-120-4C- NH
SST28SF040-120-4C- PH
SST28SF040-150-4C- EH SST28SF040-150-4C- NH SST28SF040-150-4C- U2
SST28SF040-150-4C- PH

SST28SF040-120-3C- EH SST28SF040-120-3C- NH
SST28SF040-120-3C- PH
SST28SF040-150-3C- EH SST28SF040-150-3C- NH
SST28SF040-150-3C- PH

SST28SF040-120-4I- EH SST28SF040-120-4I- NH
SST28SF040-150-4I- EH SST28SF040-150-4I- NH

SST28LF040 Valid combinations

SST28LF040-200-4C- EH SST28LF040-200-4C- NH
SST28LF040-200-4C- PH
SST28LF040-250-4C- EH SST28LF040-250-4C- NH
SST28LF040-250-4C- PH SST28LF040-250-4C- U2

SST28LF040-200-3C- EH SST28LF040-200-3C- NH
SST28LF040-200-3C- PH
SST28LF040-250-3C- EH SST28LF040-250-3C- NH
SST28LF040-250-3C- PH SST28LF040-250-3C- U2

SST28LF040-200-4I- EH SST28LF040-200-4I- NH

SST28VF040 Valid combinations

SST28VF040-250-4C- EH SST28VF040-250-4C- NH
SST28VF040-250-4C- PH
SST28VF040-300-4C- EH SST28VF040-300-4C- NH
SST28VF040-300-4C- PH SST28VF040-300-4C- U2

SST28VF040-250-3C- EH SST28VF040-250-3C- NH
SST28VF040-250-3C- PH
SST28VF040-300-3C- EH SST28VF040-300-3C- NH
SST28VF040-300-3C- PH SST28VF040-300-3C- U2

SST28VF040-250-4I- EH SST28VF040-250-4I- NH

Example: Valid combinations are those products in mass production or will be in mass production. Consult your SST sales representative to confirm availability of valid combinations and to determine availability of new combinations.



4 Megabit SuperFlash EEPROM

SST28SF040 / SST28LF040 / SST28VF040

PACKAGING DIAGRAMS

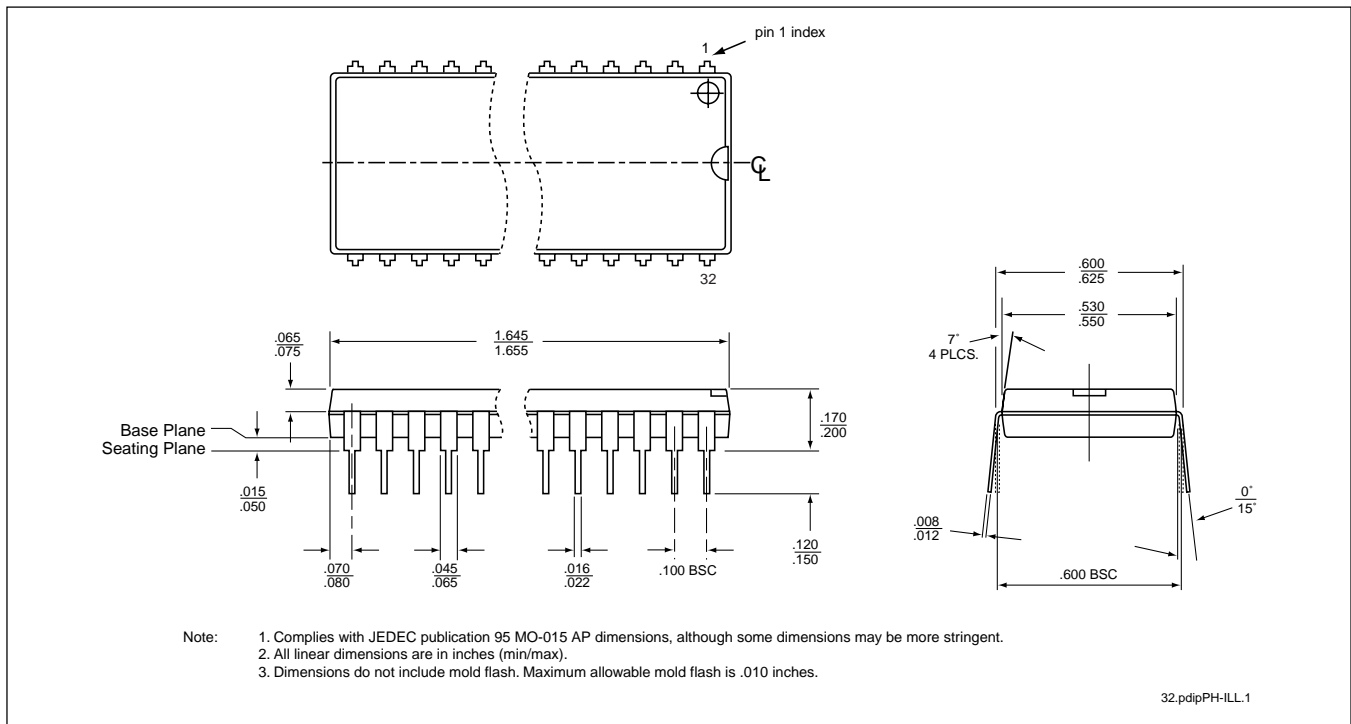

32-LEAD PLASTIC DUAL-IN-LINE PACKAGE (PDIP)

SST PACKAGE CODE: PH

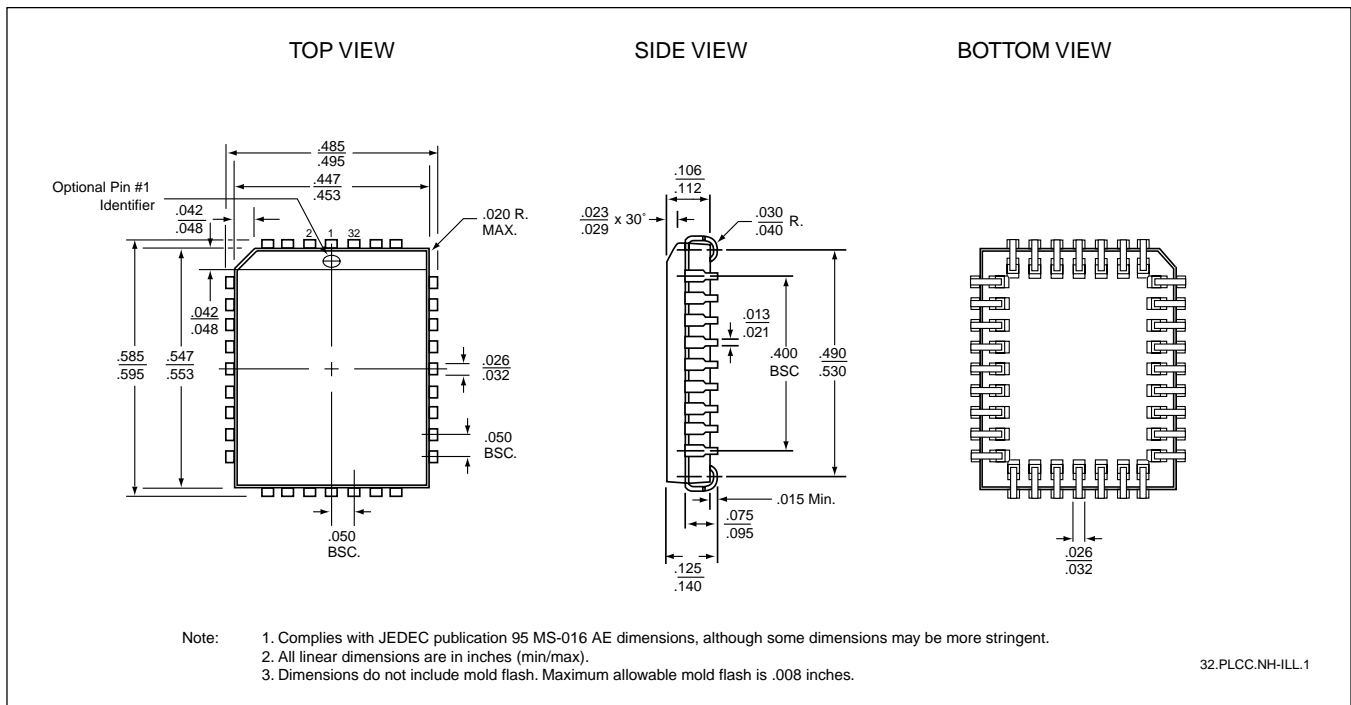

32-LEAD PLASTIC LEAD CHIP CARRIER (PLCC)

SST PACKAGE CODE: NH



4 Megabit SuperFlash EEPROM SST28SF040 / SST28LF040 / SST28VF040

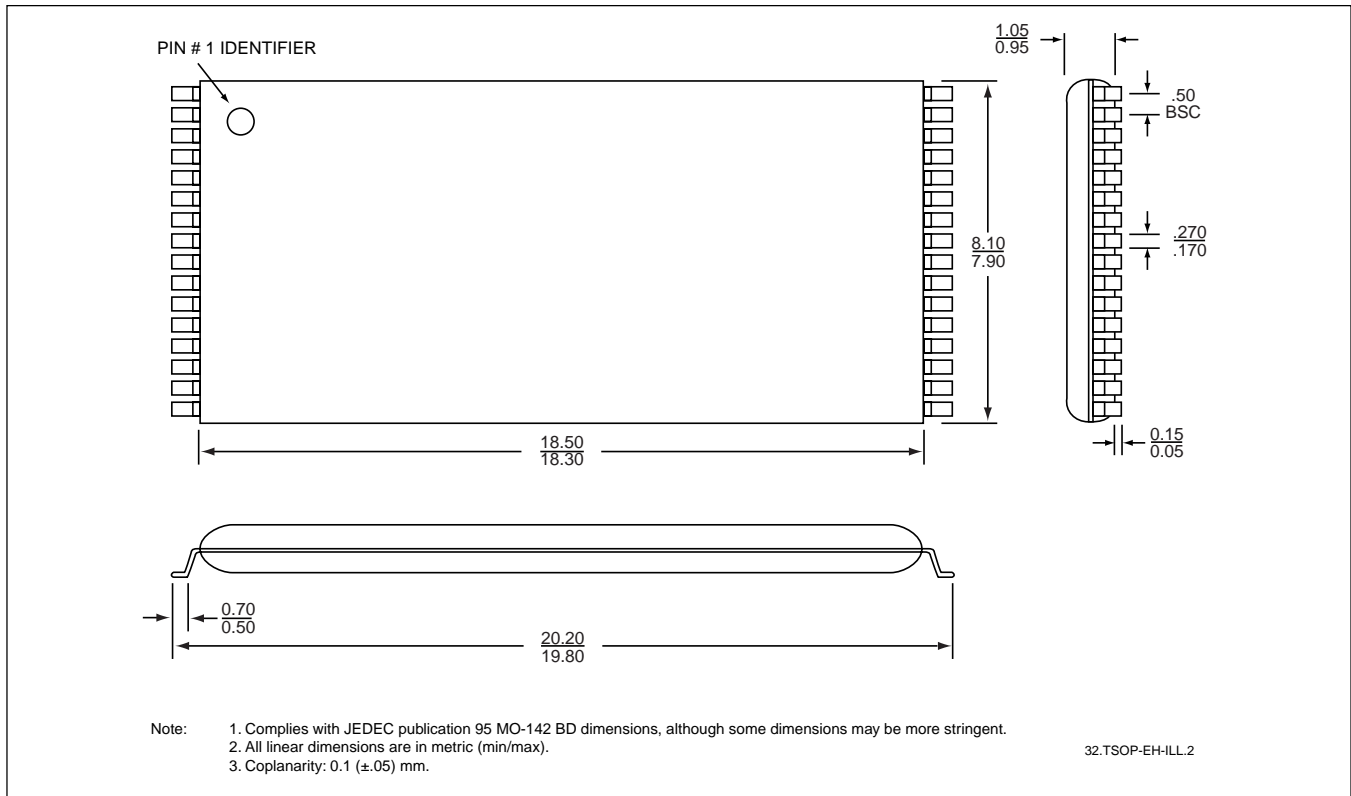

32-LEAD THIN SMALL OUTLINE PACKAGE (TSOP)
SST PACKAGE CODE: EH

4 Megabit SuperFlash EEPROM
SST28SF040 / SST28LF040 / SST28VF040





4 Megabit SuperFlash EEPROM SST28SF040 / SST28LF040 / SST28VF040

SALES OFFICES

SST Area Offices

Customer Service	(408) 523-7754
Northwest USA, Rocky Mtns. & West Canada	(408) 523-7661
Central & Southwest USA	(727) 771-8819
East USA & East Canada	(978) 356-3845
North America - Distribution	(941) 505-8893
Asia Pacific	(408) 523-7762
East Asia	(81) 45-471-1851
Europe	(44) 1932-230555
Northern Europe	(45) 3833-5000

North American Sales Representatives

Alabama M-Squared, Inc. - Huntsville	(205) 830-0498
Arizona QuadRep, Inc.	(602) 839-2102
California	
Costar - Northern	(408) 946-9339
Falcon Sales & Technology - San Marcos	(760) 591-0504
Westar Rep Company, Inc. - Calabasas	(818) 880-0594
Westar Rep Company, Inc. - Irvine	(949) 453-7900
Colorado Lange Sales, Inc.	(303) 795-3600
Florida	
M-Squared, Inc. - Clearwater	(727) 669-2408
M-Squared, Inc. - Coral Springs	(954) 753-5314
M-Squared, Inc. - Longwood	(407) 682-6662
Georgia M-Squared, Inc. - Atlanta	(770) 447-6124
Illinois	
Oasis Sales Corporation - Northern	(847) 640-1850
Rush & West Associates - Southern	(314) 965-3322
Indiana Applied Data Management	(317) 257-8949
Iowa Rush & West Associates	(319) 398-9679
Kansas Rush & West Associates	(913) 764-2700
Maryland Nexus Technology Sales	(301) 663-4159
Massachusetts A/D Sales	(978) 851-5400
Michigan Applied Data Management	(734) 741-9292
Minnesota Cahill, Schmitz & Cahill	(612) 699-0200
Missouri Rush & West Associates	(314) 965-3322
North Carolina	
M-Squared, Inc. - Charlotte	(704) 522-1150
M-Squared, Inc. - Raleigh	(919) 848-4300
New Jersey Nexus Technology Sales	(201) 947-0151
New Mexico QuadRep, Inc.	(505) 332-2417
New York	
Nexus Technology Sales	(516) 843-0100
Reagan/Compar - Endwell	(607) 754-2171
Reagan/Compar - E. Rochester	(716) 218-4370
Ohio	
Applied Data Management - Cincinnati	(513) 579-8108
Applied Data Management - Cleveland	(440) 946-6812
Oregon Thorson Pacific, Inc.	(503) 293-9001
Pennsylvania Nexus Technology Sales	(215) 675-9600
Texas	
Technical Marketing, Inc. - Carrollton	(972) 387-3601
Technical Marketing, Inc. - Houston	(713) 783-4497
Technical Marketing, Inc. - Austin	(512) 343-6976
Utah Lange Sales, Inc.	(801) 487-0843
Washington Thorson Pacific, Inc.	(425) 603-9393
Wisconsin Oasis Sales Corporation	(414) 782-6660
Canada	
Electronics Sales Professionals - Ottawa	(613) 828-6881
Electronics Sales Professionals - Toronto	(905) 856-8448
Electronics Sales Professionals - Montreal	(514) 388-6596
Thorson Pacific, Inc. - B.C.	(604) 294-3999

International Sales Representatives & Distributors

Australia ACD	(61) 3-762 7644
Belgium Memec Benelux	(32) 1540-0080
China/Hong Kong	
Actron Technology Co., Ltd. (HQ) Hong Kong	(852) 2727-3978
Actron Technology Co., Ltd. - Shanghai	(86) 21-6482-8021
Actron Technology Co., Ltd. - Shenzhen	(86) 755-376-2763
Actron Technology Co., Ltd. - Chengdu	(86) 28-553-2896
Actron Technology Co., Ltd. - Beijing	(86) 10-6261-0042
Actron Technology Co., Ltd. - Wuhan	(86) 27-8788-7226
Actron Technology Co., Ltd. - Xian	(86) 29-831-4585
MetaTech Limited (HQ) - Hong Kong	(852) 2421-2379
MetaTech Limited - Beijing	(86) 10-6858-2188
MetaTech Limited - Shanghai	(86) 21-6485-7530
MetaTech Limited - Chengdu	(86) 28-5577-415
MetaTech Limited - Fuzhou	(86) 591-378-1033
MetaTech Limited - Shenzhen	(86) 755-321-9726
Serial System Ltd. - Hong Kong	(852) 2950-0820
Serial System Ltd. - Chengdu	(86) 28-524-0208
Serial System Ltd. - Shanghai	(86) 21-6473-2080
Serial System Ltd. - Shenzhen	(86) 755-212-9076
Denmark C-88 AS	(45) 7010-4888
France	
A2M - Bron	(33) 4 72 37 0414
A2M - Sevres	(33) 1 46 23 7900
Germany	
Endrich Bauelemente	
Vertriebs GMBH - Bramstedt	(49) 4192-897910
Endrich Bauelemente	
Vertriebs GMBH - Nagold	(49) 7452-60070
India	
Team Technology - Bangalore	(91) 80-526-1102
Team Technology - Hyderabad	(91) 40-231130
Team Technology - New Delhi	(91) 11-220-5624
Ireland Curragh Technology	(353) 61 316116
Israel Spectec Electronics	(972) 3-6498404
Italy Carlo Gavazzi Cefra SpA	(39) 2-424-1471
Japan	
Asahi Electronics Co., Ltd. - Tokyo	(81) 3-3350-5418
Asahi Electronics Co., Ltd. - Kitakyushu	(81) 93-511-6471
Microtek, Inc. - Osaka	(81) 6-6263-5080
Microtek, Inc. - Tokyo	(81) 3-5300-5515
Ryoden Trading Co., Ltd. - Osaka	(81) 6-6399-3443
Ryoden Trading Co., Ltd. - Tokyo	(81) 3-5396-6218
Silicon Technology Co., Ltd.	(81) 3-3795-6461
Korea Bigshine Korea Co., Ltd.	(82) 2-832-8881
Malaysia	
MetaTech (M) SDN BHD	(60) 4-658-4276
Serial System SDN BHD	(60) 4-657-0204
Serial System - Kuala Lumpur	(60) 3-737-1243
Netherlands Memec Benelux	(31) 40-265-9399
Singapore	
MetaTech (S) Pte Ltd.	(65) 748-4844
Serial System Ltd. (HQ)	(65) 280-0200
South Africa KH Distributors	(27) 11 845-5011
Spain Tekelec Espana S.A.	(34) 91 371-7768
Switzerland Leading Technologies	(41) 27-721-7440/43
Taiwan, R.O.C.	
GCH-Sun Systems Co., Ltd. (GSS)	(886) 2-2555-0880
PCT Limited	(886) 2-2698-0098
Tonsam Corporation	(886) 2-2651-0011
United Kingdom Ambar Components, Ltd.	(44) 1296-397396

Revised 4-7-99