

# CFP2 1xN Cage Assembly, Heat Sink, Heat Sink Clip, and Connector Cover

## Product Specification S6080C Rev 1.0

Amphenol

*Now you're connected!*

### About Amphenol Commercial Products

Amphenol's commercial connector products are used in a variety of end user applications including networking, telecom, server & computer, storage & HDD, consumer electronics and entertainment, professional audio & Industrial & Military/Aerospace.

### Related Products

#### QSFP+

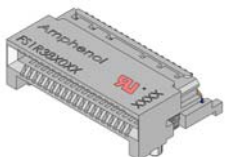

38 POSITION CONNECTOR



THRU THE BEZEL CAGE ASSEMBLY WITH HEAT SINK



1x3 BEHIND THE BEZEL CAGE ASSEMBLY WITH HEAT SINK AND LIGHT PIPES

#### CXP



CAGE AND CONNECTOR ASSEMBLY WITH ROUND PIN HEAT SINK AND ELASTOMER GASKET

Revision Date: May 7, 2013



CFP2 1x1 U98-B121-X00X  
CAGE ASSEMBLY WITH HEAT  
SINK AND CONNECTOR COVER

CFP2 1x2 U98-B221-X00X  
CAGE ASSEMBLY WITH HEAT  
SINK AND CONNECTOR COVER

CFP2 1x1 U98-B111-X0AX  
CAGE ASSEMBLY WITHOUT HEAT  
SINK OR CONNECTOR COVER

CFP2 1x2 U98-B211-X0AX  
CAGE ASSEMBLY WITHOUT HEAT  
SINK OR CONNECTOR COVER

### Overview

This short form Product Specification defines the general use and performance parameters for Amphenol's CFP2 series 1xN cage assembly.

Availability: 1x1 and 1x2 cages with heat sink and heat sink cage

### Usage

The connector system is capable of data rates up to 10 Gbps per channel (up to 10 channels) or 25 Gbps per channel (up to 8 channels) and is intended for external connections (104 positions per port) using active cabling.

### Applications

Intended for use in high speed serial interconnect applications such as:

- Clusters
- Servers
- Storage devices

# Now you're connected!

## About Amphenol Commercial Products

Amphenol's commercial connector products are used in a variety of end user applications including networking, telecom, server & computer, storage & HDD, consumer electronics and entertainment, professional audio & Industrial & Military/Aerospace.

## Related Products

### QSFP+

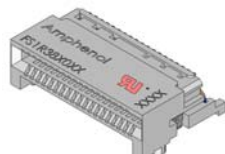

38 POSITION CONNECTOR



THRU THE BEZEL CAGE ASSEMBLY WITH HEAT SINK



1x3 BEHIND THE BEZEL CAGE ASSEMBLY WITH HEAT SINK AND LIGHT PIPES

### CXP



CAGE AND CONNECTOR ASSEMBLY WITH ROUND PIN HEAT SINK AND ELASTOMER GASKET

## General Requirements

RoHS compliant  
Footprint compatible with other industry suppliers  
Press-fit cage and connector combo for minimum 3.00 mm (0.118in) PCB thickness in belly-to-belly application  
Cages are tray packed  
Dust cover for front face is available (bulk packed)  
Proper support for cage is required during insertion into PCB  
Extraction tool required for removing the combo from PCB (consult factory)

## Connector Electrical Characteristics

Operating Voltage: 3.3V  
Operating Current: 1.875A

## Connector Mechanical Characteristics

Insertion Force: 80 N  
Withdrawal Force: 50 N  
Durability: 200 mating cycles

## Material Requirements

Unless otherwise specified, the materials for each component shall be:

- Cage: Copper alloy, matte tin over nickel or nickel only plating
- Heat Sink: Aluminum alloy, anodized or nickel plated
- Heat Sink Clip: Steel alloy
- Connector Cover: Zinc alloy, nickel plated

Temperature rise: Meets the requirement of 30° C ΔT  
Operating and storage temperature: -40° to +85° C

## Process Characteristics

Cage assembly is press-fit to customer PCB  
Connector cover is screw-mounted

## PCB Specifications

Compliant Pin Holes must be drilled and plated through to specific dimensions to prevent damage during placement of cage assembly on the PCB. See table below.

Recommended torque for connector cover mounting screws is 0.90±0.10 in·lb

Now you're connected!

**About Amphenol Commercial Products**

Amphenol's commercial connector products are used in a variety of end user applications including networking, telecom, server & computer, storage & HDD, consumer electronics and entertainment, professional audio & Industrial & Military/Aerospace.

**Related Products**

**QSFP+**

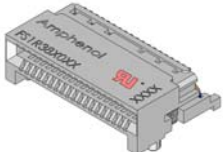

38 POSITION CONNECTOR



THRU THE BEZEL CAGE ASSEMBLY WITH HEAT SINK



1x3 BEHIND THE BEZEL CAGE ASSEMBLY WITH HEAT SINK AND LIGHT PIPES

**CXP**



CAGE AND CONNECTOR ASSEMBLY WITH ROUND PIN HEAT SINK AND ELASTOMER GASKET

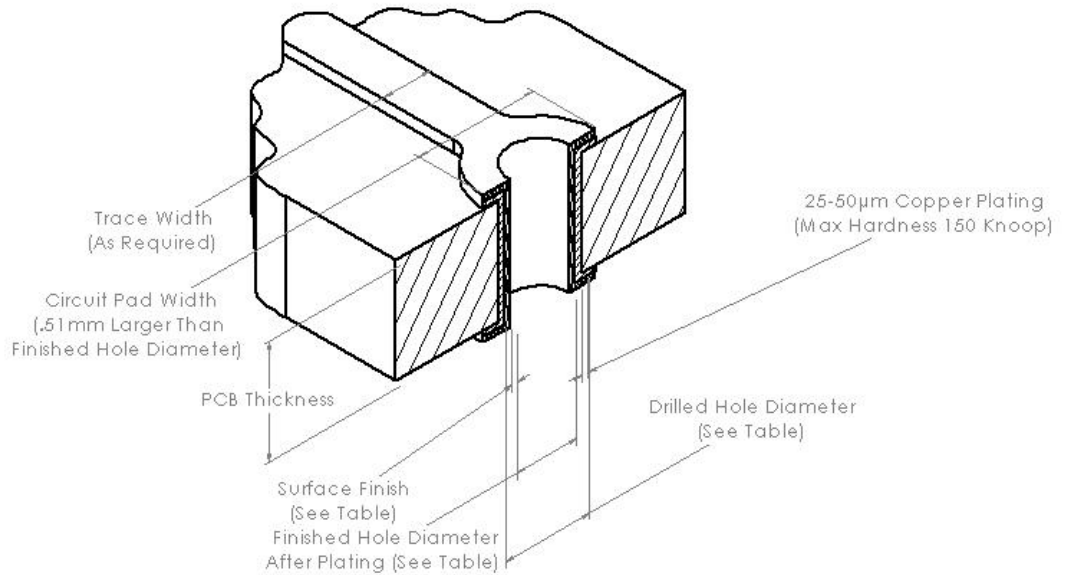

Drawing Not to Scale

Surface Finish	Drilled Hole Diameter	Finished Hole Diameter	Surface Finish Thickness
HASL SnPb	1.15±0.02	1.05 Ref	0.004-0.010
Immersion Sn	1.15±0.02	1.05 Ref	0.0005 Min.
OSP	1.15±0.02	1.05 Ref	0.0002-0.0005
Immersion Au/Ni	1.15±0.02	1.05 Ref	0.004-0.0076 (Ni) 0.0001-0.0005 (Au)

**Available Documents**

**Drawing Numbers:**

P-U98-B1X1-X0XX

CFP2 series 1x1 cage assembly

P-U98-B2X1-X0XX

CFP2 series 1x2 cage assembly

Contact factory or Authorized Amphenol representative for alternate configurations