

MUR1610FCT THRU MUR1660FCT

Ultra-Fast Recovery Rectifier Diodes

Features

- Super-fast recovery time for high efficiency
- Glass passivated chip junction
- Low leakage current
- High forward surge capability
- Solder dip maximum peak of 275 °C /7s, per JESD 22-B106

Typical Application

For use in high frequency rectification and freewheeling application in switching mode converters and inverters for consumer ,computer and telecommunication.

Mechanical Data

- Package: ITO-220AB
Molding compound meets UL 94 V-0 flammability rating,RoHS-compliant
- Terminals: Tin plated leads, solderable per J-STD-002 and JESD22-B102
- Polarity: Color Band denotes cathode end



Maximum Ratings (Ta=25°C Unless otherwise specified)

PARAMETER	Symbol	Unit	Conditions	MUR-FCT				
				1610	1615	1620	1640	1660
Repetitive Peak Reverse Voltage	V_{RRM}	V		100	150	200	400	600
Average Forward Current	I_o	A	60HZ Half-sine wave, Resistance load, Tc(Fig.1)	16				
Surge(Nonrepetitive)Forward Current	I_{FSM}	A	60HZ sine wave, 1 cycle, Ta=25°C	150				
Current Squared Time	$I^2 t$	A ² s	1ms≤t<8.3ms Tj=25°C,Rating of per diode	41				
Storage Temperature	T_{stg}	°C		-55 ~ +150				
Junction Temperature	T_j	°C		-55 ~ +150				

Electrical Characteristics (Ta=25°C Unless otherwise specified)

PARAMETER	Symbol	Unit	Conditions	MUR-FCT				
				1610	1615	1620	1640	1660
Peak Forward Voltage	VFM	V	$I_{FM}=8.0A$	0.95			1.30	1.7
Peak Reverse Current	I_{RRM1}	μA	$V_{RM}=V_{RRM}$	Ta=25°C				
	I_{RRM2}			Ta=125°C				
Maximum reverse recovery time	T_{rr}	ns	$I_F=0.5A, I_R=1.0A, I_{rr}=0.25A$	35				
Thermal Resistance	$R_{θJ-C}$	$R_{θJ-C}$	Between junction and case	2.0				



MUR1610FCT THRU MUR1660FCT

■ Characteristics (Typical)

FIG1: Forward Current Derating Curve

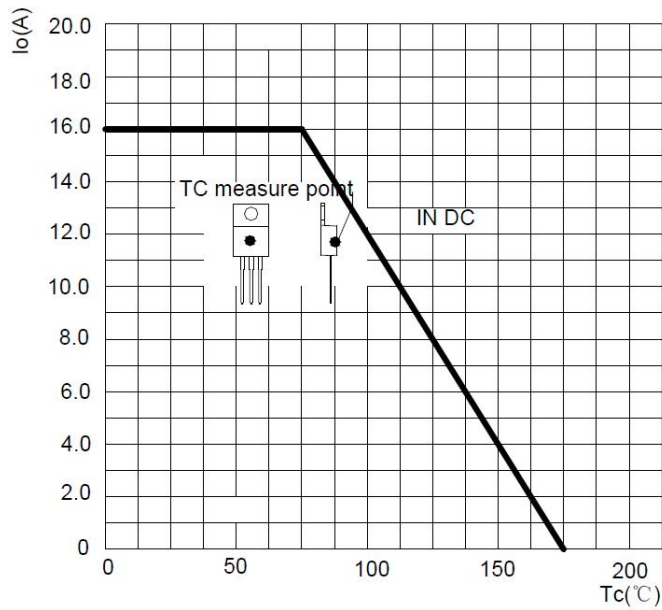

FIG2: Surge Forward Current Capability

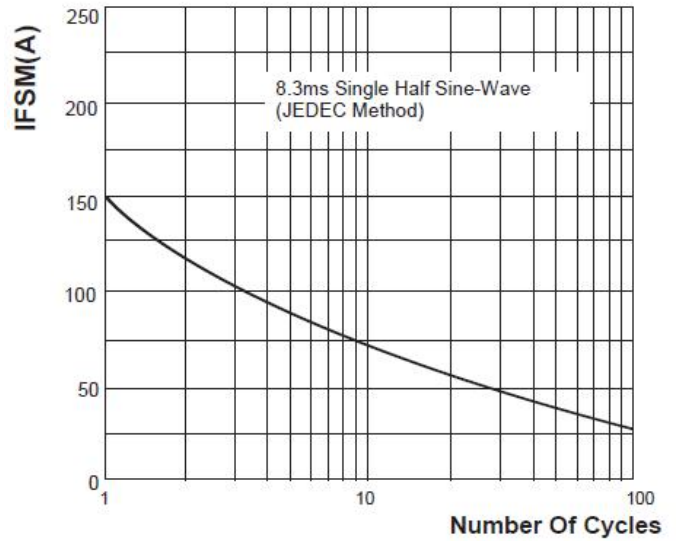

FIG3: Instantaneous Forward Voltage

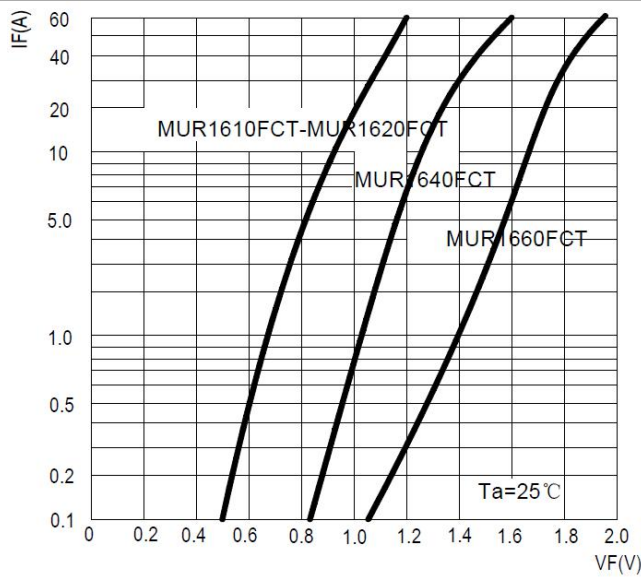

FIG4: Typical Reverse Characteristics

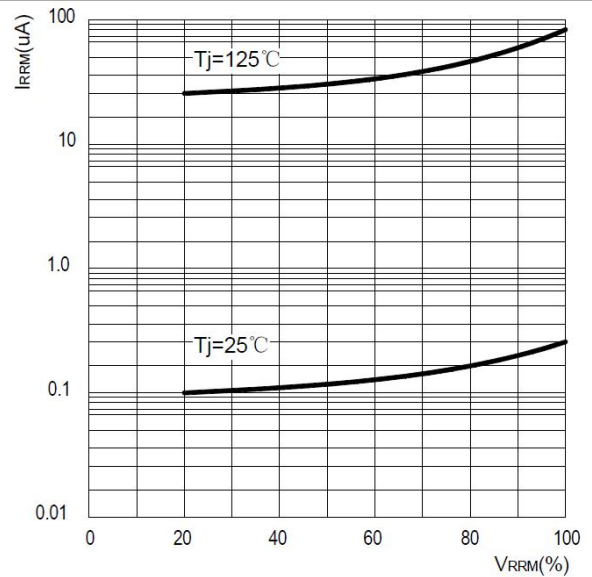
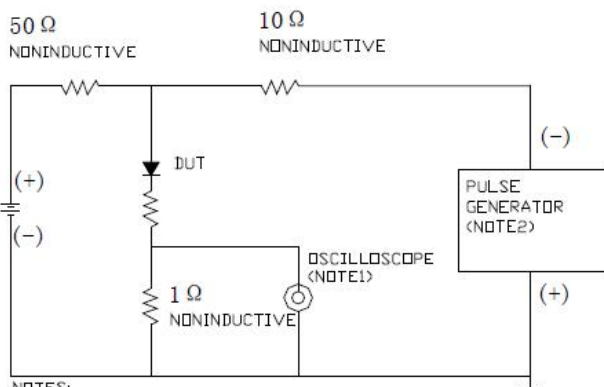
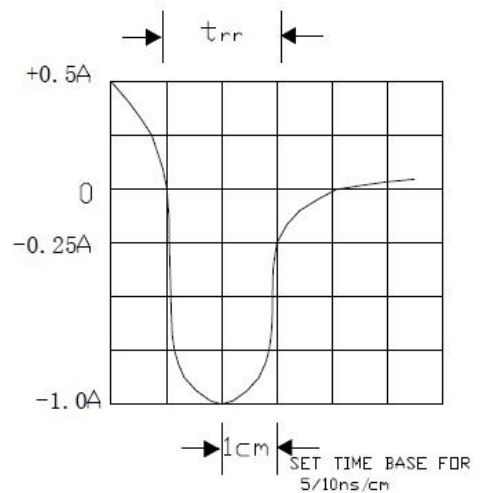

FIG5: Diagram of circuit and Testing wave form of reverse recovery time



NOTES:
 1. Rise Time = 7ns max. Input Impedance = 1MΩ 22pF
 2. Rise Time = 10ns max. Source Impedance = 50Ω



MUR1610FCT THRU MUR1660FCT

■ Ordering Information (Example)

PREFERED	PACKAGE CODE	MINIMUM PACKAGE(pcs)	INNER BOX QUANTITY(pcs)	OUTER CARTON QUANTITY(pcs)	DELIVERY MODE
MUR1610FCT~MUR1660FCT	ITO-220AB	50	1000	5000	Tube

■ Outline Dimensions

