



客户Customer: 深圳市国昂电子有限公司

日期Date: 2023年11月15日

# 承认书 SPECIFICATION

种类: 导电性高分子混合型铝电解电容器  
Description: Conductive Polymer Hybrid Aluminum Electrolytic Capacitor  
艾华料号 AISHI P/N: HSX1VM101E7CE00RAXXV  
系列 SERIES: SX  
规格尺寸 ITEM: 35V100uF(Φ6.3\*7.7)  
客户料号 Customer P/N: /  
编号No.: CRS-FX-2311034  
应用场景: 车灯

批准 Approved by			客户确认 Client Confirmed	
制作 Prepared by	审核 Checked by	批准 Approved by	审核 Checked by	批准 Approved by
				

Please return one copy with your authorized signature when you accept these specifications.  
Please note that no return within 6 months is considered to be approvable.

### 制订/修订履历表Make/revised curriculum vitae

编号NO.	版本Version	日期Date	内容Content
CRS-FX-2311034	CRS-2023-SX-01	2023/11/15	新建

Issued-date:	Name	Approval Sheet			
2023/11/15	File No	SX	Version	01	Page 2
STANDARD MANUAL					

## 1.概述Scope

此承认书使用于含有导电高分子电解质和添加剂的SX系列导电性高分子混合型铝电解电容器

These specifications specify SX series of the Conductive Polymer Hybrid Aluminum Electrolytic Capacitor.

AEC-Q200 applicable product. (符合车规认证标准)

## 2.使用温度范围Operating Temperature Range (-55~125℃)

使用温度范围是指电容在额定电压下可以稳定运行的环境温度范围

Operating temperature range is the range of ambient temperature at which the capacitor can be operated continuously at rated voltage.

## 3.特性Characteristics

除非另有说明, 标准的测量和测试环境条件如下:

Unless otherwise specified, the standard range of atmospheric conditions for making measurements and tests are as follows.

环境温度Ambient temperature : 15 to 35℃

大气压力Air pressure: 86kpa to 106kpa

若对结果有疑问, 测试则按如下标准进行

If there may be doubt on the results, measurements shall be made within the following limits.

环境温度Ambient temperature : 20±2℃

大气压力Air pressure: 86kpa to 106kpa

## 4.额定电压、浪涌电压和额定温度Rated voltage, Surge voltage and Rated temperature

额定电压 Rated voltage(V)	额定温度 Rated temperature(℃)	浪涌电压 Surge voltage (V)	电压种类 Category voltage(V)
16	125	18.40	16
25	125	28.75	25
35	125	40.25	35
50	125	57.50	50
63	125	72.45	63

Issued-date:	Name	Approval Sheet				
2023/11/15	File No	SX	Version	01	Page	3
STANDARD MANUAL						

### 5. 高低温阻抗Impedance at high and low temperature

阻抗Impedance at 100kHz at -55±3℃ or 125±2℃

阻抗比Impedance ratio	性能Performance
Z (-55℃) / Z (+20℃)	≤2.0
Z (125℃) / Z (+20℃)	≤1.5

### 6.1 电性能Electrical Characteristics

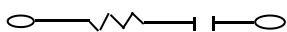
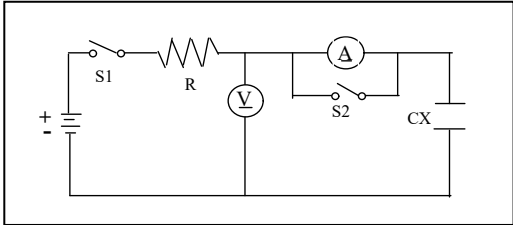
序号 No.	项目 Item	测试方法 Test method	性能 Performance
6.1.1	额定工作电压 Rated voltage	DC: 16V~63V	
6.1.2	电容量 Capacitance	测试频率Measuring frequency : 120Hz 测试电路Measuring circuit  等效串联电路Equivalent series circuit	参考特性表 Refer to characteristic table
6.1.3	损失角正切值 Dissipation Factor	测试电压Measuring voltage: 0.5Vrms or less 测试温度Measuring temperature: 20 ±2℃	参考特性表 Refer to characteristic table
6.1.4	等效串联电阻 ESR	测试频率Measuring frequency: 100kHz 测试温度Measuring temperature: 20 ±2℃ 测量位置: a) 不得超过导针焊点2mm a) Measuring point : 2mm max from the surface of a sealing resin on the lead wire b) 应在最靠近端子伸出塑料平台的两端测量 b) ESR should be measured at both of the terminal ends closest where the terminals protrude through the plastic platform.	参考特性表 Refer to characteristic table
6.1.5	漏电流 Leakage current	直流漏电流在20℃, 有串联1000±100Ω电阻的情况下以直流工作电压且充电2min后测试 DC leakage current shall be measured after 2 minutes application of the DC rated working voltage through the1000 Ω resistor at 20℃  Refer to characteristic table R : 1000±100Ω A : 电流表 DC current meter S1 : 开关Switch S2 : 电流表保护开关 Switch for protect of current meter V:电压表 DC voltage meter CX : 测试电容Testing capacitor	参考特性表 Refer to characteristic table

Issued-date:	Name	Approval Sheet				
2023/11/15	File No	SX	Version	01	Page	4
STANDARD MANUAL						

## 6.2 耐受能力 Endurance Performance

序号 No.	项目 Item	测试方法 Test method	性能 Performance
6.2.1	纹波寿命试验 Ripple Life Test	电容在125±3℃，额定电压下，施加额定纹波电流4000小时后，需在室温下放置2小时才可进行测试。 After 4000 hours continuous application of the rated voltage with the rated ripple current at 125 ±3℃, the measurements shall be measured after 2 hours exposed at room temperature.	容量变化：在初始值的±30%内 Capacitance change within ±30% of the initial value 损失角：小于规格值的200% $\tan \delta \leq 200\%$ of the initial specified value. 等效串联电阻≤规格值的200% ESR ≤ 200% of the initial specified value. 漏电流≤规格值 Leakage current ≤ initial specified value. 外观：没有明显的损伤 Appearance: No significant damage
6.2.2	振动试验 Resistance to Vibration	频率：10到2000Hz(20分钟间隔/10→2000→10Hz) Frequency: 10 to 2000Hz (20 minute interval/10→2000→10Hz) 加速度：5g Acceleration: 5g 方向：X, Y, Z (3轴) Direction : X , Y , Z (3 axes) 持续时间：4小时/轴 (共12小时) Duration : 4 hours / axial (Total 12 hours)	容量变化在初始值的±5%内 Capacitance change within ±5% of the initial value 损失角≤规格值 $\tan \delta \leq$ initial specified value. 等效串联电阻≤规格值 ESR ≤ initial specified value. 漏电流≤规格值 Leakage current ≤ initial specified value. 外观：没有明显的损伤 Appearance: No significant damage
6.2.3	可焊性 Solder ability	浸渍温度：235℃ ± 5℃ Temperature of solder bath: 235℃ ± 5℃ 浸渍时间：2秒±0.5秒 Immersion time: 2 s ± 0.5 s.	至少95%的浸渍表面覆盖有新的焊料 At least 95% of surface area of the dipped portion of the terminal shall be covered with new solder.

Issued-date:	Name	Approval Sheet				
2023/11/15	File No	SX	Version	01	Page	5
STANDARD MANUAL						

序号 No.	项目 Item	测试方法 Test method	性能 Performance
6.2.4	耐焊接热 Resistance to soldering heat	(1)焊料浴方法Solder bath method 温度Temperature : 260 ±5°C 持续时间Duration : 10±1 seconds 一直到间距为1.0mm的情况下	容量变化在初始值的±5%内 Capacitance change: Within ± 5% of initial capacitance 损失角≤ 规格值 Tanδ≤ initial specified value. 等效串联电阻≤ 规格值 ESR ≤ initial specified value. 漏电流≤规格值 Leakage current ≤initial specified value. 外观: 没有明显的损伤 Appearance:No significant damage
6.2.5	偏高湿度 Biased Humidity	温度Temperature : 85±2°C 相对湿度Relative humidity : 80%-90% 持续时间Duration : 1000 (-0/+48) hrs 使用电压: 额定电压 Applied voltage : Rated Voltage	电容变化在初始值的±30%内 Capacitance change within ±30% of initial value 损失角≤ 规格值的200% tan δ ≤ 200% of the initial specified value. 等效串联电阻≤ 规格值的200% ESR ≤ 200% of the initial specified value. 漏电流≤规格值 Leakage current ≤initial specified value.
6.2.6	快速变温 Rapid change of temperature	TA=下限类别温度, TB=上限类别温度; 在TA或TB的放置时间: 30分钟; TA与TB间转换时间: ◎ 车规: 1分钟之内; 循环次数: ◎ 车规: 1000次; 试验结束至少放置16小时, 或让电容恢复至20°C, 观察电容外观 及测量。 TA=Lower bound category temperature, TB=Upper limit category temperature; Time of placement in TA or TB: 30minutes; Conversion time between TA and TB: Within a minute; Cycle number: 1000 Cycles the measurements shall be measured after 16 hours or restore the capacitor to 20°C	容量变化: 在初始值的±10%内 Capacitance change : Within ±10% of the initial capacitance 损失角: 小于或等于规格值 tanδ ≤ initial specified value. 漏电流: 小于或等于规格值 Leakage current ≤ initial specified value.

Issued-date:	Name	Approval Sheet				
2023/11/15	File No	SX	Version	01	Page	6
STANDARD MANUAL						

序号 No.	项目 Item	测试方法 Test method	性能 Performance
6.2.7	浪涌电压 Surge voltage	<p>额定浪涌电压充电30s后，在室温下放电5min30s。这一过程重复1000次，每一次循环的时间为6 min，测试温度为15°C-35°C。测试电路如下图所示： Rated surge voltage shall be applied (switch on) for 30 seconds and then shall be applied (switch off) with discharge for 5min30 seconds at room temperature . This cycle shall be repeated for 1000 cycles . Duration of one cycle is 6 minutes . Test temperature: 15°C-35°C The test circuit is as follows:</p> <p>Test circuit :</p> <p>Ⓟ : DC voltmeter R1: Protective resistor 1kΩ R2: Discharging resistor 1kΩ Cx: Capacitor under test (10pcs)</p> <p>备注：若浪涌电压测试标准不能满足整机实际ON/OFF要求，请在样品阶段与我司RD确认，并将具体测试要求反馈给我司，包括测试电压、浪涌电流、充放频率、循环次数、测试温度及性能表现等。Remark: If the surge voltage test standard is inconsistent with the actual ON/OFF requirements of the machine, Please confirm with our RD at the sample stage. And feedback the specific test requirements to our company, including test voltage, surge current, charge and discharge frequency, cycle times, test temperature and performance, etc.</p>	<p>电容变化在初始值的±20%内 Capacitance change within ±20% of initial value 损失角≤规格值的200% <math>\tan \delta \leq 200\%</math> of the initial specified value. 等效串联电阻≤规格值的200% ESR ≤ 200% of the initial specified value. 漏电流≤规格值 Leakage current ≤ initial specified value.</p>
6.2.8	高温储存 High temperature storage	<p>电容在125°C±3°C下放置1000小时后，需在室温下放置2小时才可进行测试。 Capacitor is placed under 125 °C±3 °C after 1000 hours, should be placed at room temperature 2 hours can be tested.</p>	<p>容量变化：在初始值的±30%内 Capacitance change within ±30% of the initial value 损失角：小于规格值的200% <math>\tan \delta \leq 200\%</math> of the initial specified value. 等效串联电阻≤规格值的200% ESR ≤ 200% of the initial specified value. 漏电流：小于或等于规格值 Leakage current ≤ initial specified value.</p>
6.2.9	耐溶剂性 Resistance to solvent	<p>温度Temperature: 25°C±5°C 溶液Solution: Chemical-OKEM 浸泡时间: 3~3.5分钟 Soak time: 3~3.5 minutes 循环次数: 3次 Cycle number: 3 cycles</p>	<p>外观：没有明显的损伤 Appearance: No significant damage</p>

Issued-date:	Name	Approval Sheet				
2023/11/15	File No	SX	Version	01	Page	7
STANDARD MANUAL						

序号 No.	项目 Item	测试方法 Test method	性能 Performance
6.2.10	端子强度 Terminal Strength	SMD先回流焊接 1.将元件焊接在PCB板上(100mm×40mm FR4 PCB板, 板厚为1.6mm±0.2mm) 2.对元件侧面施加一个17.7N的水平推力, 持续时间60+1s The element is reflow soldered first 1.The element is welded to the PCB board (100mm×40mm FR4 PCB with thickness of 1.6mm±0.2mm) 2.A horizontal thrust of 17.7N is applied to the side of the element for a duration of 60+1sec.	电容变化在初始值的±5%内 Capacitance change within ±5% of initial value 损失角≤规格值 Tanδ≤ initial specified value. 等效串联电阻≤规格值 ESR ≤ initial specified value. 漏电流≤规格值 Leakage current ≤initial specified value. 外观: 没有明显的损伤 Appearance:No significant damage

## 备注 REMARKS

非加电可靠性项目, 漏电可能回升超SPEC值, 若遇到此类情况, 在加电处理后测量漏电流。

加电处理条件: 电容器在125℃下加载直流额定电压120分钟。

需在室温下放置2小时才可进行测试

For non-powered reliability projects, leakage current may rise above the SPEC value. If such situations occurs, please measure the leakage current after powering on.

Treatment conditions: Applying DC-rated voltage on the capacitor at 125°C for 120 minutes.

The measurements should be measured after 2 hours exposed at room temperature.

Issued-date:	Name	Approval Sheet				
2023/11/15	File No	SX	Version	01	Page	8
STANDARD MANUAL						



7.物料编码PART No. SYSTEM

H	SX	1V	M	101	E7C	E00	R	AXXV
---	----	----	---	-----	-----	-----	---	------

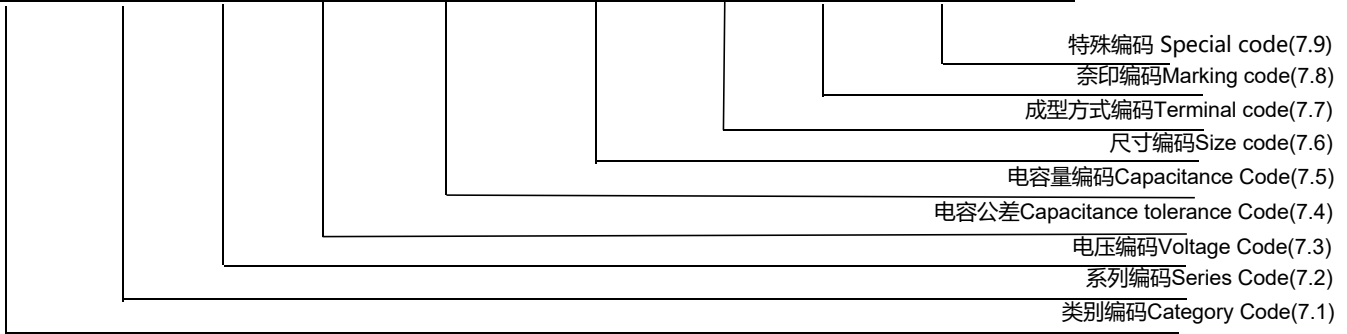

7.1 类别编码Category Code

编码Code	H
类别编码Category Code	混合型电容Hybrid Capacitor

7.2 系列编码Series Code

编码Code	SX
系列编码Series Code	SX

7.3 电压编码Voltage Code

编码Code	1C	1E	1V	1H	1J
电压编码VoltageCode(W.V)	16	25	35	50	63

7.4 电容公差Capacitance tolerance

“M”代表 -20 % ~ +20 %                      “M”stands for -20 % ~ +20 %

7.5 容量编码Capacitance Code

编码Code	680	101	181	471	561	681	821
容量Capacitance (uF )	68	100	180	470	560	680	820

7.6 尺寸编码Size Code

编码Code	E06	E7C	F9R	FBR	GAR	GCR	GGR
直径D (Φ)	6.3	6.3	8	8	10	10	10
高度H (mm)	6	7.7	9.5	11.5	10.5	12.5	16.5

7.7 成型方式编码 Terminal Code

编码Code	D00	E00
其他 Other	贴片、散装SMD&Bulk	贴片、编带SMD&Taping

7.8 捺印编码Marking Code

编码Code	S	R
捺印Marking	天蓝Sky blue	红色Red

7.9 特殊编码 Special Code

“AXXV” 代表常规四轮车用电子，“AXXV” stands for normal four-wheelers products.

Issued-date:	Name	Approval Sheet				
2023/11/15	File No	SX	Version	01	Page	9
STANDARD MANUAL						

### 8. 结构Construction

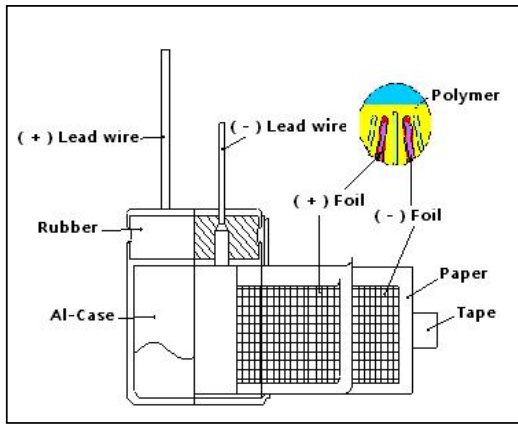

导线: 固体镀锡铜包钢线  
 Lead wires : Solid tinned copper weld steel wire  
 导线端子: 高纯铝 Al-boss : High pure aluminum  
 电解纸: 马尼拉麻 Paper : Manila hemp  
 铝箔 (正极): 高纯铝 Al-foil (Anode) : High pure aluminum  
 铝箔 (负极): 碳箔、高纯铝  
 Al-foil (Cathode) : Carbon foil. High purity aluminum  
 镀膜铝壳: 铝+镀膜 (耐压400V以上) Coating AL-case: Aluminum+coating (Can withstand voltage above 400V)  
 胶带: 聚酯 Tape : Polyester  
 胶粒: (树脂)压缩成型 IIR-Rubber: Resin (Compression molding)  
 导线和圆柱端子通过焊接连接在一起  
 The lead wire and the Al-boss are welded together.  
 导线扁平端子与铝箔通过按压连接在一起  
 The Al-tab and the Al-foil are stitched to join together.  
 卷绕的素子外部以阴极箔包裹  
 The outer most Al-foil spiral of the element is cathode.  
 导电高分子用作电解质  
 Conductive polymer is used as the electrolyte.

### 9. 尺寸图Outer dimensions (单位Unit:mm)

尺寸Outer dimensions (单位Unit:mm)

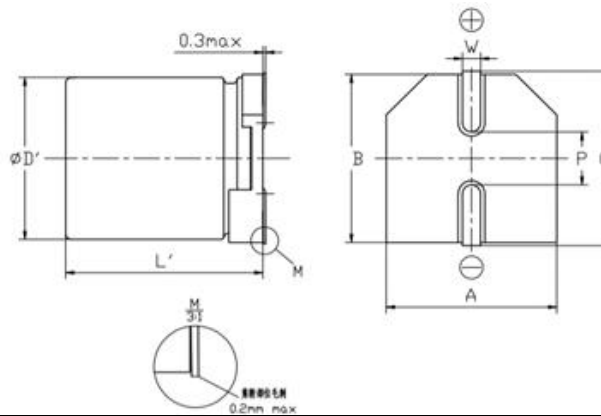

尺寸编码 Size Code	ΦD' (mm)	ΦD'(mm) Tolerance	L' (mm)	L'(mm) Tolerance	A±0.2 (mm)	B±0.2 (mm)	C±0.2 (mm)	P±0.2 (mm)	W (mm)
E7C	6.3	-0.1~+0.5	7.7	-0.3~+0.3	6.6	6.6	7.2	1.9	0.65±0.15

焊盘尺寸 Soldering pad dimensions (单位Unit:mm)

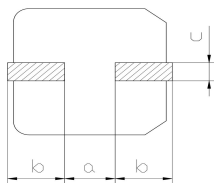

尺寸 Size	a	b	c
Φ6.3	2.1	3.5	1.6
Φ8	2.8	4.2	1.9
Φ10	4.3	4.4	1.9

### 10. 特性表格Characteristics Table

序号 N o.	艾华料号 AISHI P/N	额定 工作电压 Rated Work Voltage (V.DC)	电容量 Nominal Capacitanc e 120Hz,20 °C(μF)	电容量 公差 Capacitanc e Tolerance (%)	温度 Oper Temp (°C)	尺寸 Nominal Case Size D*L (mm)	等效 串联电阻 E.S.R 100KHz 20°C (mΩmax)	最大漏电流 Leakage current 20°C(μA max) 2Minutes/W.V	损失 D.F 120Hz, 20°C (%max)	纹波电流 Ripple Current 100KHz,125°C (mA.rms)	寿命 Load Life (Hours)
1	HSX1VM101E7CE00RAXXV	35	100	-20~+20	125	6.3*7.7	30	35	10	1700	4000

Issued-date:	Name	Approval Sheet				
2023/11/15	File No	SX	Version	01	Page	10

**纹波电流频率系数 Frequency coefficient for ripple current**

频率 Frequency	$120\text{Hz} \leq f < 1 \text{ kHz}$	$1 \text{ kHz} \leq f < 10 \text{ kHz}$	$10 \text{ kHz} \leq f < 100 \text{ kHz}$	$100 \text{ kHz} \leq f < 300 \text{ kHz}$
系数 Coefficient	0.05	0.3	0.7	1

**11. 捺印 Marking**

除非另有说明，捺印应该清晰地印在电容上

Unless otherwise specified. Capacitor shall be clearly marked on it body.

SX:	系列 Series	SX
3:	年编码 Year code	2023年
C:	额定电压 Rated voltage	35
100:	额定电容 Rated Capacitance	100
1:	月编码 Month code	1月
01:	日编码 Day code	1日
印字油墨为红色 The color of marking ink is red.		

系列代码 Series code

系列	SD	SE	SF	SG	.....
代码	SD	SE	SF	SG	.....

年份代码 Year Code

年份	2018	2019	2020	2021	2022	2023	2024	2025	2026	2027	2028	2029	2030
代码	K	M	N	1	2	3	4	5	6	7	8	9	A
年份	2031	2032	2033	2034	2035	2036	2037	2038	2039	2040	2041	2042	...
代码	B	C	D	E	F	G	H	K	M	N	1	2	...

电压代码 W.V code

电压	16	25	35	50	63	80	100
代码	A	B	C	D	E	F	G

容量代码 Cap. Value code

容量	6.8	68	100	180	270	470	560	1000	1500	.....
代码	6R8	68	100	180	270	470	560	10C	15C	.....

月份代码 Month code

月份	1	2	3	4	5	6	7	8	9	10	11	12
代码	1	2	3	4	5	6	7	8	9	A	B	C

批次号代码 Lot number code

批次号	001	002	003	.....	010	.....	099	100	101	.....	126	.....
代码	01	02	03	.....	10	.....	99	AA	AB	.....	BA	.....

Issued-date:	Name	Approval Sheet				
2023/11/15	File No	SX	Version	01	Page	11
STANDARD MANUAL						

12. 匣盒带 Box cassette (单位Unit:mm)

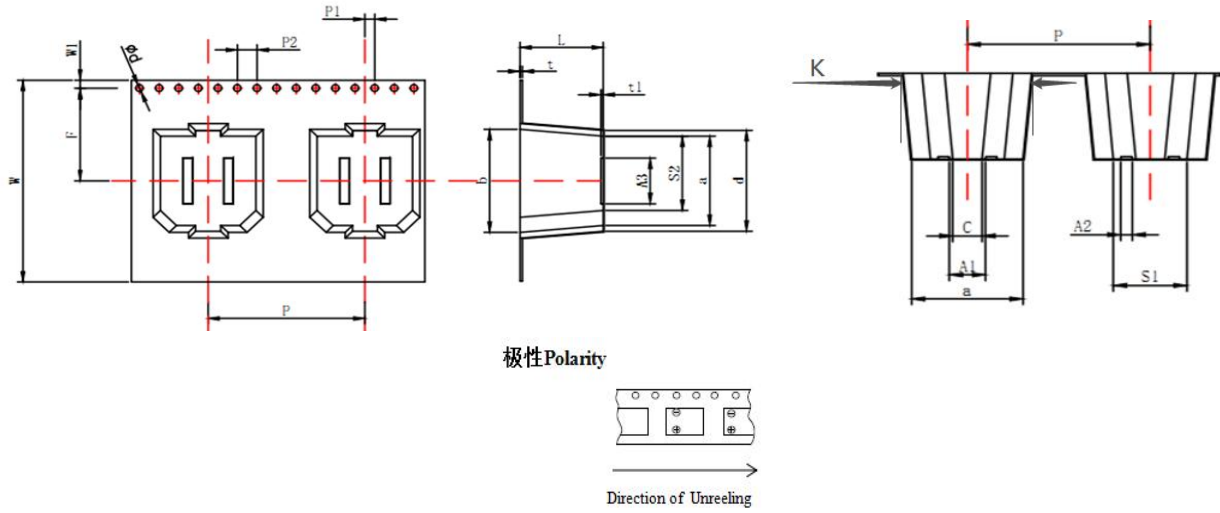

尺寸编码 Size Code	Φd	L	P	P1	P2	t	t1	W	W1	F	A1	A2	A3	S1	S2	a	b	c	d
0/0.1	±0.1	±0.1	±0.1	±0.1	±0.1	±0.05	±0.1	±0.3	±0.1	±0.1	±0.1	±0.1	±0.1	±0.1	±0.1	±0.1	±0.1	±0.1	±0.1
E7C	1.5	8.5	12.0	2.0	4.0	0.5	0.35	16.0	1.75	7.5	2.5	0.8	3.5	4.3	5.2	6.8	7.8	1.6	8.0

Issued-date:	Name	Approval Sheet				
2023/11/15	File No	SX	Version	01	Page	12
STANDARD MANUAL						

### 13. 包装Packing

Bulk: Standard

Direction of Unreeling

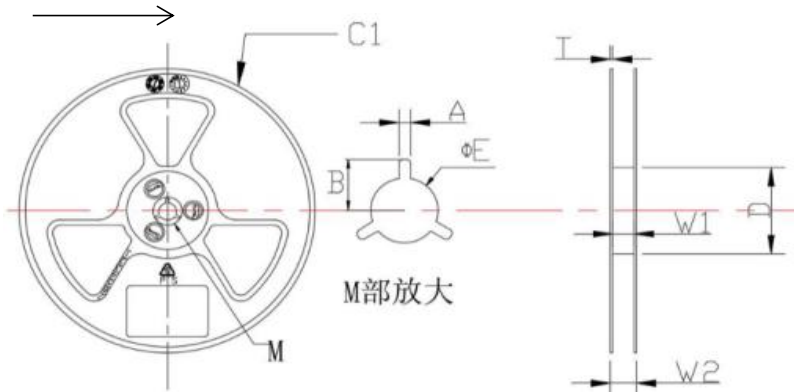

胶盘加真空包装

plastic carrier reel and vacuum packing

Aishi	
P/N:	
CUSTOMER P/N	
SIZE:	
Q'TY	
DATE	

胶盘尺寸 plastic carrier reel dimensions (单位Unit:mm)

尺寸	C1±2	A±0.2	B±0.2	W1±2	E±0.4	W2±1	T±0.2	D±0.5
6.3拍	380	2.6	10.8	16	13.8	21.7	2	100
8拍、10拍	380	2.6	10.8	24	13.8	29.7	2	80

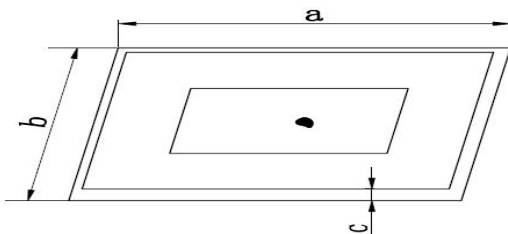

Zipper bag

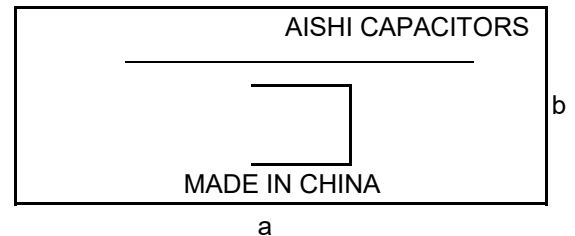

#### 13.1 编带包装Tape Packing

编带Taping: 标准Standard

分类Classification 产品尺寸 Product size D*L(mm)	标准Standard			
	承载卷轴 Carrier reel/ (pcs)	外包箱 Outer carton/ reel) 390*225*390 (mm)	承载卷轴尺寸Carrier reel size/ (mm)	
6.3*4.5	1200	10	W1±2 16	W2±1 21.7
6.3*6	1000	10	16	21.7
6.3*7.7	800	10	16	21.7

产品尺寸 Product size D*L(mm)	承载卷轴 Carrier reel/ (pcs)	外包箱 Outer carton/ reel) 390*225*390 (mm)	承载卷轴尺寸Carrier reel size/ (mm)	
			W1±2	W2±1
8*9.5	600	6	24	29.7
8*11.5	500	6	24	29.7
10*10.5	500	6	24	29.7

Issued-date:	Name	Approval Sheet				
2023/11/15	File No	SX	Version	01	Page	13

## 14. 操作注意事项 Operating Precautions

### 14.1 极性 Polarity

AishiCAP是具有正负极的混合型铝电解电容，使用中不可反接，若接反，则电容会因为漏电流不断增大或短路而造成寿命缩短。

AishiCAP is a solid aluminum electrolytic capacitor with Hybrid conductive polymer. Do not reverse the polarity when using. If it is used with the polarities reversed, its life may shorten because of increasing leakage current or short circuit.

### 14.2 禁止电路 Prohibited circuits

因为焊接及其它动作可造成电容的漏电流增加，AishiCAP不可使用在下列电路中：

Since problems can be expected due to leakage current increasing during soldering and other processes, AishiCAP cannot be used in the following circuits

1)高阻抗电路1) High impedance circuits;

2)耦合电路2) Coupling circuits;

3)时限恒量电路3) Time constant circuits;

4)为提高耐电压而串联两个或多个电容于电路中

4) Connection of two or more capacitors in series for higher withstand voltage;

5)电路因漏电流过大而有坏的影响5)Circuits to get bad influence by big leakage current

\* 除漏电流的波动上升外，电容的使用条件如在承认书中规定的高温 and 低温，温湿和耐受性条件都会影响电容量。若电容作为时限恒量电容使用，因其对电容量的变动的敏感性，电容量的改变会造成影响。不要将其作为时限恒量电容使用，同时若因电压原因要串联多个AishiCAP电容，请联系湖南艾华集团股份有限公司。

\* In addition to the leakage current fluctuation above, the operational conditions such as characteristics at high and low temperature, damp heat and endurance stipulated in the specifications will affect the capacitance. The fluctuation of the capacitance may cause problem if it is used as a time constant capacitor, which is extremely sensitive to the fluctuation of the capacitance. Do not use it as a time constant capacitor. Additionally, please contact Hunan Aihua Group Co., Ltd. for usage of two or more AishiCAP in series for voltage proof.

6)ON-OFF电路6)ON-OFF circuits

请勿在一天内频繁开-关10000次以上的ON-OFF电路中使用本产品。用于此类电路时，请务必将电路条件等告知我们。

Do not use this product in an on-off circuit that frequently turns on-off more than 10000 times in a day. When used in such circuits, please be sure to inform us of circuit conditions, etc

### 14.3 电压 Over voltage

电压若超过额定电压，即便只是一瞬间也可能造成短路

Over voltage exceeding the rated voltage may not be applied even for an instant as it may cause a short circuit.

### 14.4 快速充放电 Rapid charge and discharge

快速充放电是不适用的（为了维持高的可靠性）。若充放瞬间电流超过10A或10倍允许纹波电流超过10A，为防止快速的充放电造成电容短路、漏电增大及容量衰减，电路中应加上一个保护电路用以分流过大的电流。

Rapid charging and discharging is unsuitable (for maintenance of high-proof reliability). If the instantaneous current of charging and discharging is more than 10A or 10 times of the allowable ripple current is more than 10A, in order to prevent the capacitor short, leakage increase and capacity reduction caused by rapid charging and discharging, a protection circuit shall be added to the circuit to reduce the excessive current.

### 14.5 焊接注意事项 Considerations when soldering

焊接条件要在承认书的规定范围内。若没有遵守承认书的条件，则电容漏电流可能急剧增加，容量衰减。

The soldering conditions are to be within the range prescribed in specifications. If the specifications are not followed, there is a possibility of the cosmetic deflection, the intensive increase of leakage current, and the capacitance reduction.

使用需知 Things to be noted before mounting.

Issued-date:	Name	Approval Sheet				
2023/11/15	File No	SX	Version	01	Page	14
STANDARD MANUAL						

(a) 已安装过的或加过电压的AishiCAP请勿再使用。经历了周期性电性能测试的AishiCAP不可再用。

(a) Do not reuse AishiCAP that have been assembled in a set and energized. Excluding AishiCAP that have been removed for measuring electrical characteristics during a periodic inspection, AishiCAP cannot be reused.

(b) AishiCAP贮藏一年时间后，漏电流可能会增大，使用前，请在125℃，额定电压及接有1 kΩ电阻的条件下充电2小时。

(b) Leakage current may increase when AishiCAP are stored for one year. In this case, apply rated voltage for 2 hours at 125℃ with load of 1 kΩ resistor.

(c) Reflow soldering 回流焊接

进行焊接的时候，产品上部及端子部分温度、时间的推荐范围如下表所示：

When welding, the recommended temperature and time range of the upper part and terminal part of the product are shown in the table below:

第1次回流之后，必须确保电容器的温度已经完全冷却到室温（5~30℃）后方可进行第2次回流。随焊接条件变化，在焊接后漏电流可能会增大，甚至超过规格值，通过加载电压使用后，漏电流会逐渐变小。

加电处理条件：电容在125℃下加载直流额定电压120分钟。

After the first reflux, the second reflux can be carried out only after the temperature of the capacitor has been completely cooled to room temperature (5 ~ 30 ℃). With the change of welding conditions, the leakage current may increase or even exceed the specification value after welding. After being used by loading voltage, the leakage current will gradually decrease.

Treatment conditions: Applying DC-rated voltage on the capacitor at 125℃ for 120 minutes.

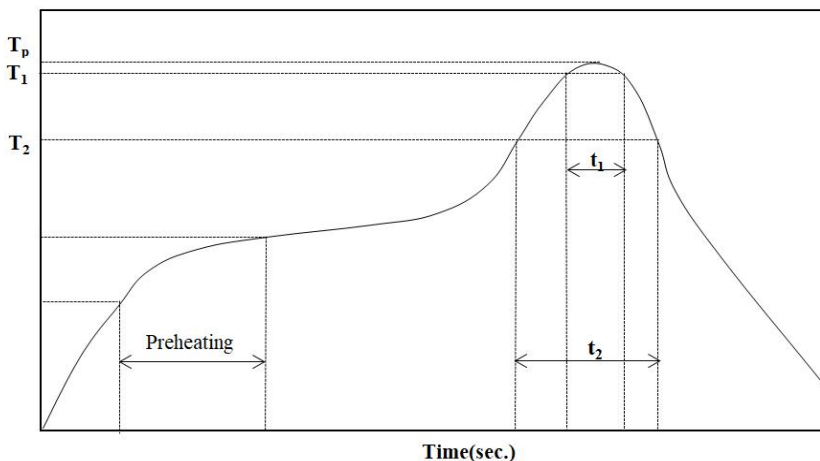

Preheating	Tp	T1	T2	t1	t2	Reflow cycle
150℃~180℃ ≤90s	250℃	245℃	217℃	≤30s	≤90s	1
150℃~180℃ ≤90s	245℃	240℃	217℃	≤20s	≤70s	2

贴装型产品为回流焊专用零部件。请在红外热风并用等气氛热处理方法。请勿用于浸流焊。

Mount products are special parts for reflow soldering. Please heat treat with infrared hot air and other atmosphere. Do not use for immersion welding.

请在产品规格书规定的焊接条件（预热，温度，时间，次数等）范围内焊接。温度测量方法，因用环氧系粘剂在电容器上方粘贴了热电偶，量产测温时需注意。

Please weld within the welding conditions (preheating, temperature, time, times, etc.) specified in the product specification. For the temperature measurement method, due to the thermocouple pasted above the capacitor with epoxy adhesive, attention should be paid to during mass production temperature measurement.

即使是在推荐的回流焊条件下，也可能发生电容器外壳变色或膨胀现象，但并不影响产品的可靠性，敬请谅解。

Even under the recommended reflow soldering conditions, the outer box of the capacitor may change color or cargo expansion, but it will not affect the reliability of the product. Please understand.

Issued-date:	Name	Approval Sheet				
2023/11/15	File No	SX	Version	01	Page	15
STANDARD MANUAL						

回流焊等产生的热量可能会使阴极标示部位的印字发生裂纹，但并不影响产品的可靠性，敬请谅解。

The heat generated by reflow welding may crack the printing on the marked part of the cathode, but it does not affect the reliability of the product. Please understand.

使用VPS回流焊时，因温度急剧上升可能会发生特性变化或外观变化引起的贴装问题，所以推荐3℃/秒以下的升温速度条件下使用。详情请洽询。

When using VPS reflow soldering, mounting problems caused by characteristic changes or appearance changes may occur due to the sharp rise of temperature. Therefore, it is recommended to use it at a heating rate below 3 °C / s. Please inquire for details.

#### (d) Handling after soldering 焊接后处理

在这之后，不要倾斜，弯曲或扭曲AishiCAP Do not tilt, bend or twist the AishiCAP after it

不可通过抓捏AishiCAP来移动印刷电路板Do not move the PCB with catching AishiCAP itself.

堆叠印刷电路板时确保AishiCAP没有碰触到其它电路板或部件

When stacking PCB make sure that the AishiCAP does not touch other PCB or components.

不可将AishiCAP与其它物品堆放Do not dump the AishiCAP with objects.

#### 14.6使用AishiCAP于工业设备Use of AishiCAP for industrial equipments

为确保AishiCAP在工业设备上的可靠性，设计必须与之相符。

To ensure reliability when the AishiCAP is used in industrial equipments, design must allow for its

#### 14.7使用AishiCAP于生命保障系统Use of AishiCAP for human life equipments

若使用于与人类生命有关的设备上（如空间设备、航空设备、原子设备等），请与湖南艾华集团股份有限公司详细咨询，不要使用有湖南艾华集团股份有限公司承认文件的AishiCAP。

In case of using in equipments regarding human life(e.g. Space equipment, aeronautic equipment and atomic equipment etc.), be sure to talk over the matter with Hunan Aihua Group Co., Ltd.

#### 14.8贮存Storage

1) 请将AishiCAP贮存于温度在5to 35℃之间，相对湿度在75%以下的没有阳光直射的环境中，如果可能可贮存于包裹中。(如果在35到85℃，他应该少于三个月)

1) Store AishiCAP with the temperature range between 5to 35°C (If between 35 to 85°C, it should be less than three months) , and the relative humidity of 75% or less without direct sunshine and store AishiCAP in the package states if possible.

2) AishiCAP请在使用前再打开包装袋并且快速用完。

AishiCAP are recommended that you shall open the bag just before use and AishiCAP shall be used up.

3) 不要在有水、盐水、油及凝结状况的地方贮存AishiCAP

Never store AishiCAP in which it is directly exposed to water, brine, oil or in condensation status.

4) 禁止在含有毒气体的区域放置AishiCAP (如：硫化氢、亚硫酸、亚硝酸、氯气、氨水等)

Never store AishiCAP in any area filled with poisonous gases(including hydrogen sulfide, sulfurous acid, nitrous acid, chlorine and ammonia).

5) 禁止在有紫外线或放射性辐射的区域放置AishiCAP。

Never store AishiCAP in any area to which ultraviolet and/or radial rays are radiated.

#### 6) 存储时间storage time

产品出货后，未开封有效期一年 The unopened product is valid for one year after shipment.

产品内包装开封后，有效期一个月 The product is valid for one month after the inner package is opened.

Issued-date:	Name	Approval Sheet				
2023/11/15	File No	SX	Version	01	Page	16
STANDARD MANUAL						



#### 14.9 清洗Cleaning

关于HCFC，可用高浓酒精，石油，匝烯，水和表面活性剂以及别的溶剂（单独或混合使用）浸泡，用超声波，煮沸，蒸发等方法按制作者的建议清洗。更多详情请联系。

Concerning about HCFC, higher alcohol system, petroleum system, terpene system, water system with surface active agent and other solvents the washing way (separateness or combinations) by soak, ultrasonic wave, boil, vapor etc. is confirmed under the maker's recommendation. Please contact us if you require further details.

#### 14.10为AishiCAP设计电路的说明Notes on circuit designs for AishiCAP

##### 14.10.1 执行Performance

在承认书中指定的额定性能范围内使用AishiCAP。

Use AishiCAP within the rating and performance ranges defined in this specifications.

##### 14.10.2使用温度和纹波电流Operating temperature and ripple current

如果AishiCAP的使用温度超过了上限温度（125℃）或是有过载纹波电流通过，则有较大可能使寿命缩短，或漏电流增大，造成AishiCAP失效。

If AishiCAP is used at a temperature higher than the upper category temperature(125℃), or excess ripple current flows through AishiCAP, there are high possibilities of life cycle reduction or leakage current increasing to cause AishiCAP defective.

##### 14.10.3漏电流Leakage current

漏电流会因焊接条件而有些微的上升，加载直流电压可使电容自我修复，漏电流逐渐减小。

The leakage current of AishiCAP may increase slightly by soldering conditions. The application of DC voltage enables the capacitors to be repaired by itself and this leads the leakage current to be smaller gradually.

##### 14.10.4使用电压Applied voltage

为了保证AishiCAP的可靠性，加载到AishiCAP上的电压最好小于其额定电压。直流加交流电压的峰值应小于额定电压。

For the reliability of AishiCAP, it is recommended that the voltage applied to AishiCAP should be less than the rated voltage. Peak value of the the dc and ac voltage should not exceed its rated voltage.

##### 14.10.5失效模式Failure mode

AishiCAP含有导电聚合物，其寿命的终止大部分是由于偶然失效模式，主要是开路。如果开路，AishiCAP将会因持续电流流过而过热，然后铝壳会因内部压力的增加而脱离电容。

AishiCAP contains a conductive polymer. The life ends mostly due to random failure mode, mainly open circuit. In case of open circuit, AishiCAP can be overheated by continuous current flow, then case of AishiCAP would be removed by internal pressure increasing.

##### 14.10.6变更提前通知Advance consultation for changing

如果承认书改变，我们会提前通知

It is conducted under an advance consultation with you if this specification is changed.

Issued-date:	Name	Approval Sheet				
2023/11/15	File No	SX	Version	01	Page	17
STANDARD MANUAL						