

EPF *iprotect*[®]

(Ecological Pressure Filter)

High Pressure Filters
Max 700 l/min - 450 bar



A compact, cost effective pressure filter solution

Designed with the *iprotect*[®] patented filtration technology

The Parker EPF *iprotect*[®] (Ecological High Pressure Filter) is designed to provide high quality filtration of hydraulic systems, providing new possibilities to reduce the cost of ownership by improving their productivity and profitability.

A radical, innovative approach was applied with the design of the EPF *iprotect*[®], suitable for a flow capacity up to 700 l/min at 450 bar working pressure.

A new patented design of the filter element allows integration of the bypass valve and element core as re-usable parts in the filter bowl. This makes the product fool proof as there is no risk of forgetting to re-install re-usable parts.

With less space being available for filters, Parker has taken on board the requirement to provide more compact solutions. A unique feature is the filter element remains inside the filter bowl when changing the filter element. This can save over 500mm of space envelope in comparison with traditional high pressure filters.



Product Features:

The patented element design guarantees the quality of filtration, which directly impacts the oil cleanliness level as the usage of pirate type after market filters with unknown quality of filter media is excluded. This in-built safety has a direct positive impact on the productivity and profitability of equipment.

- Guaranteed quality of filtration
- More Compact Solutions are possible
- Filter element remains in filter bowl during filter service
- Reduce waste of 50%
- No risk of mistakes due to monkey-proof design
- Unique OEM branding opportunities
- Easy to integrate into hydraulic manifold solutions



ENGINEERING YOUR SUCCESS.

EPF *iprotect*®

High Pressure Filters

Features	Advantages	Benefits
Patented filter element	Avoid use of non-genuine parts	Guaranteed quality of filtration
Filter element remains in filter bowl	Less space needed to change/service filter	More compact solutions are possible
		Reduce service time for filter over 40%
Environmentally-friendly design	Reduces environmental waste over 50%	Lower disposal cost
Service-friendly product design	No handling of loose re-usable parts	No risk of making mistakes during change of element
Bypass valve integral part of filter bowl	Easy to integrate in manifold systems	More compact and lower cost of manifold (only one cavity is needed)
	Lower pressure lost across filter	Saving energy, improving system efficiency
Wide range of differential pressure indicators	Continuous feedback of condition filter elements	Optimizing filter element life
		Contributes to scheduled maintenance

Typical Applications

- Mobile working hydraulics
- Mobile drive system
- Pilot line filtration
- Servo controls
- Reverse flow valve applications
- Industrial working hydraulics
- Control systems

The Parker EPF *iprotect*® series patented bypass valve technology

Bypass settings are available up to 7 bar or completely blocked in conjunction with patented, high strength filter elements (available October 2010). The principle is

based on differential pressure measurement across the filter element. During bypass only a part of the mainflow is flowing through the bypass valve.

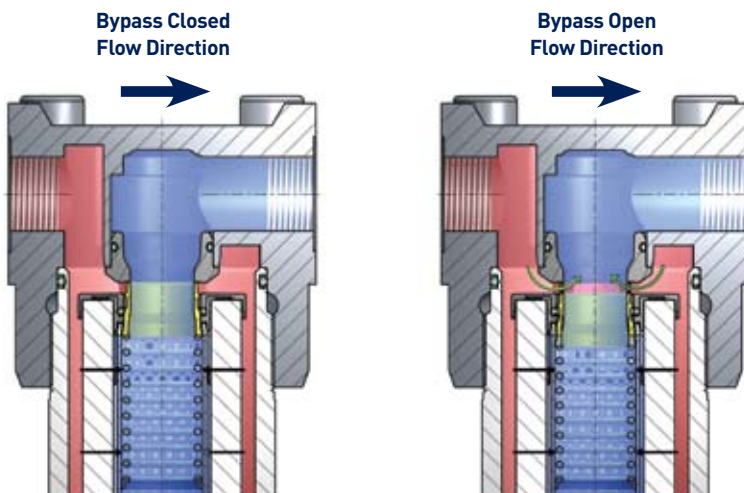

EPF *iprotect*® applies the latest generation of Microglass III filter media. The patented element design guarantees the quality of filtration.

WARNING — USER RESPONSIBILITY

FAILURE OR IMPROPER SELECTION OR IMPROPER USE OF THE PRODUCTS DESCRIBED HEREIN OR RELATED ITEMS CAN CAUSE DEATH, PERSONAL INJURY AND PROPERTY DAMAGE.

- This document and other information from Parker-Hannifin Corporation, its subsidiaries and authorized distributors provide product or system options for further investigation by users having technical expertise.
- The user, through its own analysis and testing, is solely responsible for making the final selection of the system and components and assuring that all performance, endurance, maintenance, safety and warning requirements of the application are met. The user must analyze all aspects of the application, follow applicable industry standards, and follow the information concerning the product in the current product catalogue and in any other materials provided from Parker or its subsidiaries or authorized distributors.
- To the extent that Parker or its subsidiaries or authorized distributors provide component or system options based upon data or specifications provided by the user, the user is responsible for determining that such data and specifications are suitable and sufficient for all applications and reasonably foreseeable uses of the components or systems.

Protecting your system and the environment

Protect your system performance and profit

The new *iprotect*® generation of filter elements provide high filtration performance combined with patented technology. The bespoke design prevents the use of pirate type alternatives.



Less space needed to accommodate the filter

More compact solutions are possible as the filter element remains in the filter bowl during change of filter element. Compared to traditional solutions it does not only save space, it also reduces the required manual handling during the filter change process.



Saving cost and our environment

What does it take to introduce a new ground-breaking design which saves the environment? Parker's EPF *iprotect*® applies a re-usable element core and bypass, both integral parts of the filter bowl. This solution avoids the handling of re-usable parts during element change and reduces over 50% disposal weight.



Smart valve technology

Parker hydraulic control valve technology is applied for the reusable bypass valve. This leakage-free valve has a patented interface with the filter element, which ensures that genuine parts are always applied. With bypass settings up to 7 bar filtration during cold start conditions, more compact solutions, can be realised. The valve also optimizes the flow path, reducing the pressure lost across the filter.



Easier to integrate

Parker has set the trend to integrate filtration into manifolds. With Parker's EPF *iprotect*® we have taken the design one step further. Only one cavity is needed to accommodate the filter instead of two, this is because the re-usable bypass valve is integrated into the filter bowl, reducing space and cost.



Customized solutions

Parker's motion & control technologies provide new opportunities for our customers. Customized manifolds or duplex filters, as in this example offer complete automatic change-over. The EPF *iprotect*® contributes to realizing new solutions, improving your productivity and profitability.



A protective 'gene'

The performance and profitability of systems directly depends upon the filter media.



It goes without saying that Parker's patented products aim to avoid the use of unknown filter performance, jeopardizing safety and performance. Our Microglass III media is continuously upgraded and acts as a protective 'gene' in the system.

When going into reverse

Parker's EPF can be equipped with an optional reverse flow. This valve assembly is integrated in the element end cap and isolates the filter medium during reverse flow conditions.



A new patented design of the filter element allows integration of the bypass valve and element core as re-usable parts in the filter bowl. This results in cost reduction when integrating the high pressure filter in manifold type solutions. But it also reduces the waste when changing the filter element by over 50% as the element core is an integral part of the filter bowl.

The design of the EPF *iprotect*®, is unique, there is no need to re-install any re-usable parts as with some other filters in the market. This makes the product fool proof as there is no risk of forgetting to re-install re-usable parts.



Replacing the filter element:

- Thanks to the filter lock the element remains in the bowl.
- Drain the filter housing using the plugged drain port.
- Pull out the old element. The re-usable element core and bypass valve are integral parts of the bowl.
- Filtration is from 'Out to In,' the element core is located in the clean oil side.
- Just drop the new element in the bowl.

EPF *i*protect®

Size 1

Specification EPF *i*protect® Size 1

Specification

Nominal flow 40 l/min

Pressure ratings

Maximum allowable operating pressure 450 bar
Filter housing pressure pulse fatigue tested 10⁶ pulses 0-450 bar

Connections

Inlet and outlet connections are threaded internally

Connection style

BSP 1/2»
SAE 1/2»

Filter housing

Head material cast iron (GSI)
Bowl material steel

Seal material

Nitrile or Fluorelastomer

Operating temperature range

Seal material Nitrile : -40C to +100 C
Seal material Fluorelastomer : -20C to +120 C

Bypass valve & Indicator settings

Bypass	Indicator
3.5 bar	2.5 bar
5.0 bar	4.0 bar
7.0 bar	5.0 bar
Blocked	7.0 bar

Filter element

Degree of filtration
Determined by multipass test in accordance to ISO16889

Flow fatigue characteristics

Filter media is supported so that the optimal fatigue life is achieved (ISO 3724)

Microglass III

Supported with epoxy coated metal wire mesh, end cap material reinforced composite and reusable metal inner core. Collapse pressure 25 bar (ISO 2941)

High collapse elements

To be used when bypass blocked option is selected Collapse pressure 210 bar (ISO 2941)

Indicator options

Indicating differential pressure:

2.5 +/- 0.3 bar
5.0 +/- 0.3 bar
7.0 +/- 0.3 bar

Visual M3

Electrical T1

Electronic F1 (PNP)

Electronic F2 (NPN)

Atex versions are available on request

Weights (kg)

EPF Size 1: 3

Fluid compatibility

- Hydraulic mineral oils H to class HLPD (DIN51524)
- Operating fluids DIN ISO 2943
- Lubrication fluids ISO6743, APJ, DIN 51517, ACEA, ASTM
- Vegetable oils
- 60/40 Water Glycols
- Industrial grade phosphate esters
- Non aggressive synthetic oils
- Non aggressive bio-degradable oils (HETG, HEPG and HEES to VDMA 24568)

EPF *i*protect® - Size 1 (Inline)

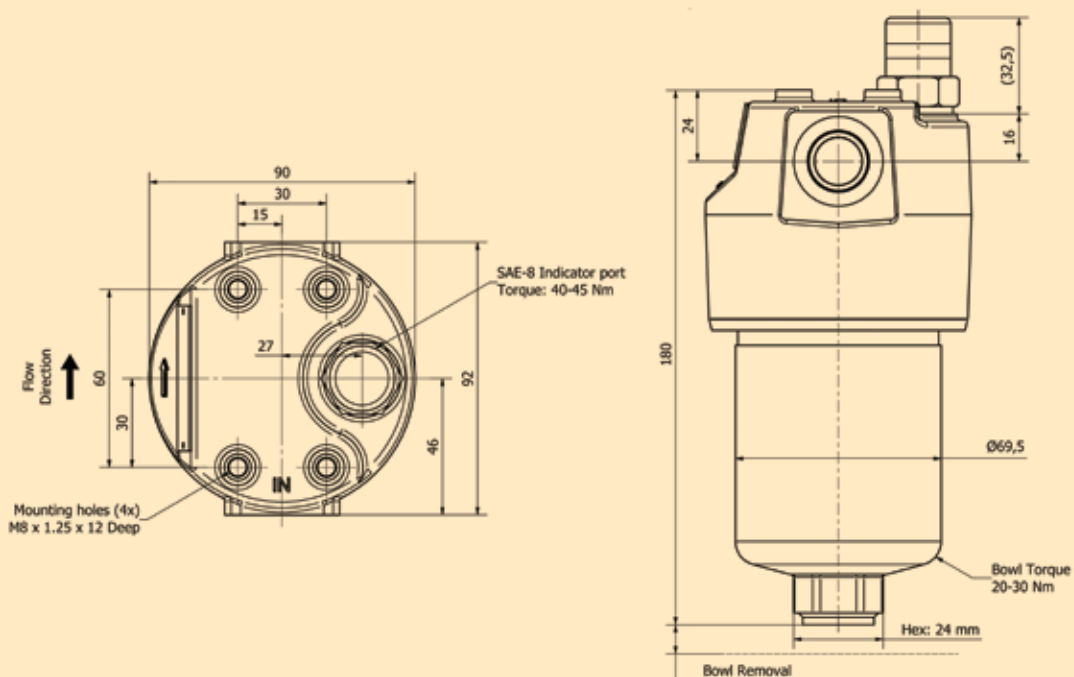

EPF *iprotect*® Size 1 Pressure Drop Curves

With 3.5 bar bypass the recommended initial pressure drop max is 1.2 bar

With 7.0 bar bypass the recommended initial pressure drop max is 2.3 bar

If the medium used has a viscosity different from 30cSt, pressure drop over the filter can be estimated as follows:

The total Δp = housing Δp + (element Δp x working viscosity/30).

Size 1 L1	Dp Standard Elements (bar)			
Flow (l/min)	02QI	05QI	10QI	20QI
0	0.000	0.000	0.000	0.000
10	0.765	0.487	0.223	0.128
20	1.530	0.973	0.447	0.256
30	2.295	1.460	0.670	0.385
40	3.060	1.947	0.893	0.513
50	3.825	2.433	1.117	0.6420
60		2.920	1.340	0.77

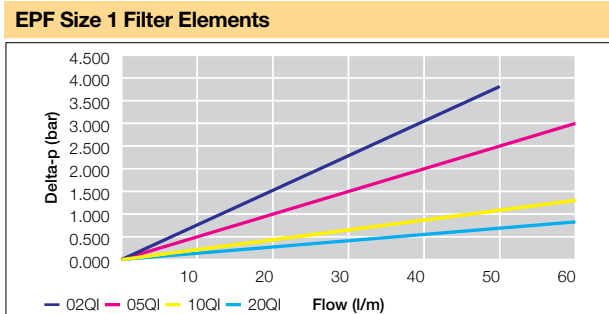

Size 1 L1	Dp Elements with reverse flow valve (bar)			
Flow (l/min)	02QIR	05QIR	10QIR	20QIR
0	0	0	0	0
10	1.15	0.73	0.33	0.19
20	2.30	1.46	0.67	0.38
30	3.44	2.19	1.01	0.58
40		2.92	1.34	0.77
50		3.65	1.68	0.96
60			2.01	1.16

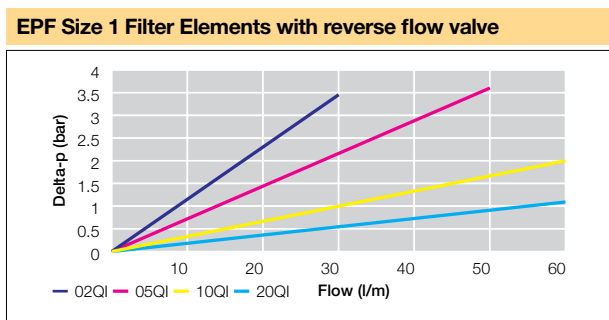

Empty Housing (bar)	
Flow (l/min)	Housing
0	0
10	0.028
20	0.057
30	0.085
40	0.113
50	0.142
60	0.17

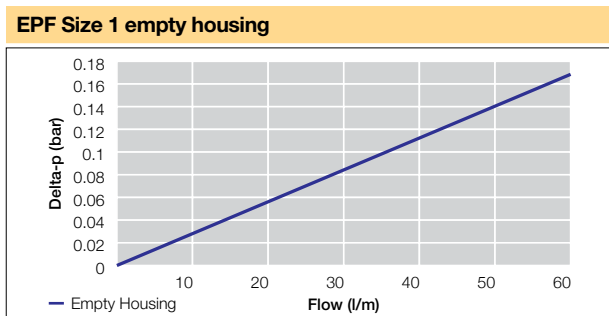

EPF *iprotect*®

Size 2

Specification EPF *iprotect*® Size 2

Specification

Nominal flow >100 l/min

Pressure ratings

Maximum allowable operating pressure 450 bar
Filter housing pressure pulse fatigue tested 10⁶ pulses 0-450 bar

Connections

Inlet and outlet connections are threaded internally

Connection style

BSP 3/4»
Thread SAE12
Thread M27, ISO 6149
SAE flange 3/4»-6000M
SAE flange 3/4»-6000
Manifold 3/4»SAE Code 62 Flange Face

Filter housing

Head material cast iron (GSI)
Bowl material steel

Seal material

Nitrile of Fluorelastomer

Operating temperature range

Seal material Nitrile : -40C to +100 C
Seal material Fluorelastomer : -20C to +120 C

Bypass valve & Indicator settings

Bypass	Indicator
3.5 bar	2.5 bar
5.0 bar	4.0 bar
7.0 bar	5.0 bar
Blocked	7.0 bar

Filter element

Degree of filtration
Determined by multipass test in accordance to ISO16889

Flow fatigue characteristics

Filter media is supported so that the optimal fatigue life is achieved (ISO 3724)

Microglass III

Supported with epoxy coated metal wire mesh, end cap material reinforced composite and reusable metal inner core. Collapse pressure 25 bar (ISO 2941)

High collapse elements

To be used when bypass blocked option is selected

Collapse pressure 210 bar (ISO 2941)

Indicator options

Indicating differential pressure:

2.5 +/- 0.3 bar
5.0 +/- 0.3 bar
7.0 +/- 0.3 bar

Visual M3

Electrical T1

Electronic F1 (PNP)

Electronic F2 (NPN)

Atex versions are available on request

Weights (kg)

EPF Size 2 length 1: 4,2
EPF Size 2 length 2: 5,7

Fluid compatibility

- Hydraulic mineral oils H to class HLPD (DIN51524)
- Operating fluids DIN ISO 2943
- Lubrication fluids ISO6743, APJ, DIN 51517, ACEA, ASTM
- Vegetable oils
- 60/40 Water Glycols
- Industrial grade phosphate esters
- Non aggressive synthetic oils
- Non aggressive bio-degradable oils (HETG, HEPG and HEES to VDMA 24568)

EPF *iprotect*® - Size 2 (Inline)

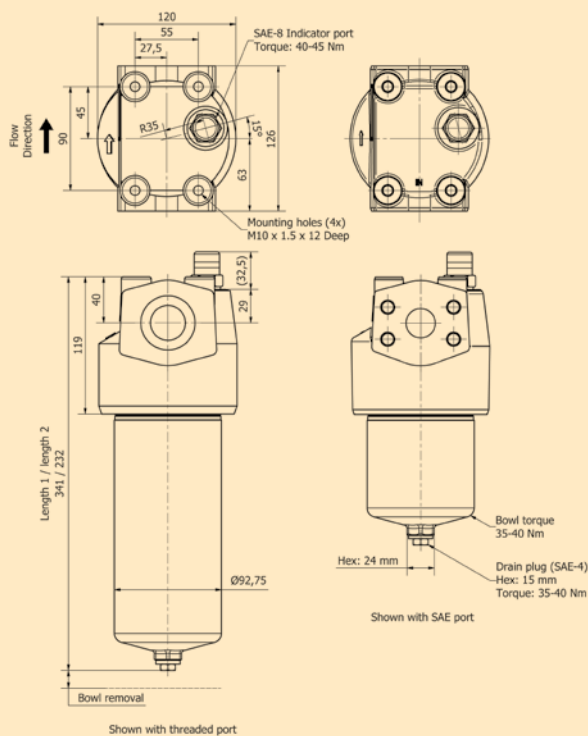

EPF *iprotect*® - Size 2 (Manifold)

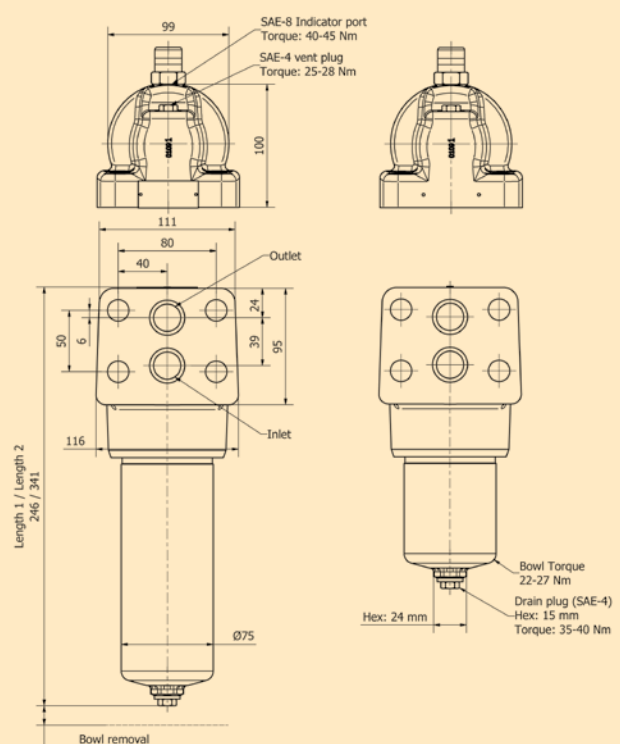

EPF iprotect® Size 2 Pressure Drop Curves

With 3.5 bar bypass the recommended initial pressure drop max is 1.2 bar

With 7.0 bar bypass the recommended initial pressure drop max is 2.3 bar

If the medium used has a viscosity different from 30cSt, pressure drop over the filter can be estimated as follows:

The total Δp = housing Δp_h + (element $\Delta p_e \times$ working viscosity/30).

EPF2 L1	Dp Elements EPF2 L1 (bar)			
Flow (l/min)	02QI	05QI	10QI	20QI
0	0	0	0	0
20	0.49	0.33	0.27	0.19
40	0.98	0.67	0.54	0.38
60	1.47	1.00	0.81	0.57
80	1.96	1.33	1.09	0.76
100	2.45	1.66	1.36	0.95
120	2.94	2.00	1.63	1.14
140	3.43	2.33	1.90	1.33

EPF2 L1	Dp Elements with Reverse Flow Valve EPF2 L1 (bar)			
Flow (l/min)	02QIR	05QIR	10QIR	20QIR
0	0	0	0	0.00
20	0.74	0.50	0.41	0.29
40	1.47	1.00	0.81	0.57
60	2.21	1.50	1.22	0.86
80	2.94	2.00	1.63	1.15
100	3.68	2.50	2.04	1.43
120	4.41	3.00	2.44	1.71
140	5.14	3.49	2.86	2.00

Empty Housing (bar)	
Flow (l/min)	Housing
0	0
20	0.01
40	0.06
60	0.14
80	0.24
100	0.36
120	0.49
140	0.65

EPF2 L2	Dp Elements EPF2 L2 (bar)			
Flow (l/min)	02QI	05QI	10QI	20QI
0	0	0	0	0
20	0.274	0.2	0.171	0.133
40	0.549	0.4	0.343	0.266
60	0.823	0.6	0.514	0.399
80	1.097	0.8	0.686	0.531
100	1.371	1	0.857	0.664
120	1.646	1.2	1.03	0.797
140	1.92	1.4	1.2	0.93

EPF2 L2	Dp Elements with Reverse Flow Valve EPF2 L2 (bar)			
Flow (l/min)	02QIR	05QIR	10QIR	20QIR
0	0	0	0	0
20	0.411	0.3	0.2565	0.1995
40	0.8235	0.6	0.5145	0.399
60	1.2345	0.9	0.771	0.5985
80	1.6455	1.2	1.029	0.7965
100	2.0565	1.5	1.2855	0.996
120	2.469	1.8	1.545	1.1955
140	2.88	2.1	1.8	1.395

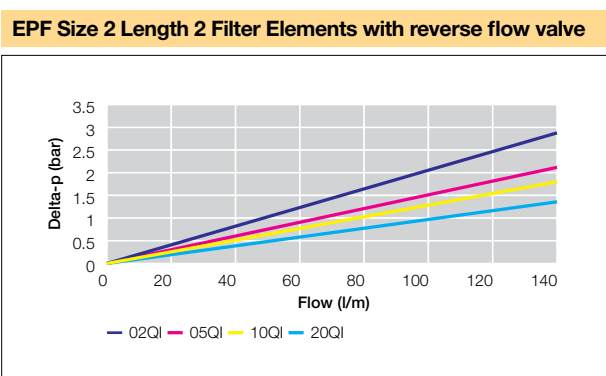
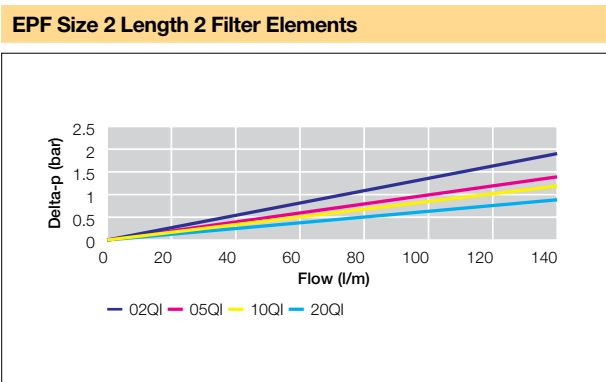
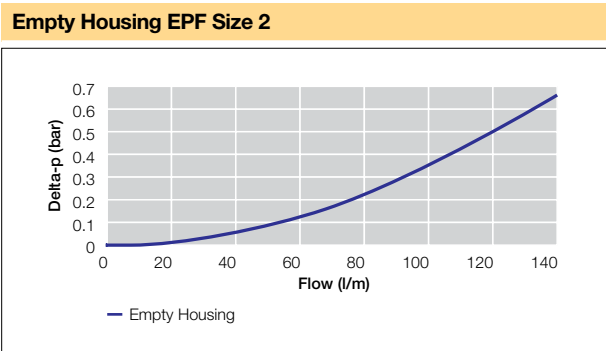
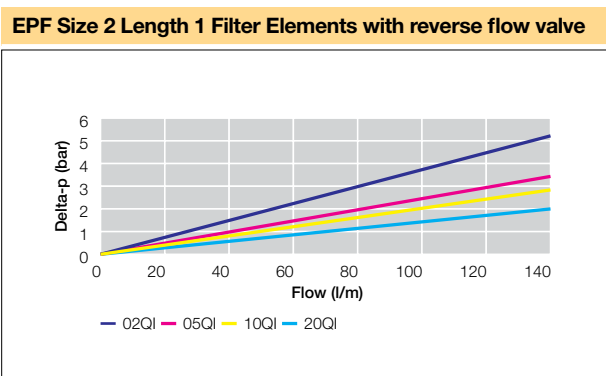
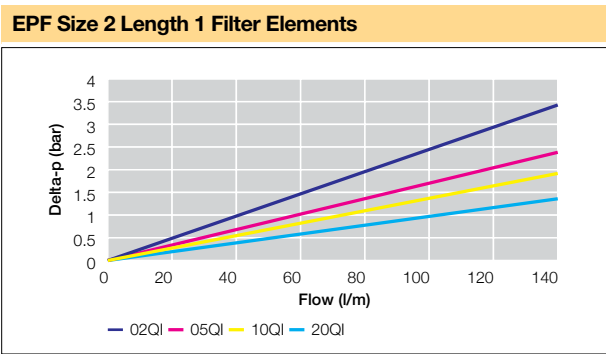

EPF *iprotect*®

Size 3

Specification EPF *iprotect*® Size 3

Specification

Nominal flow >160 l/min

Pressure ratings

Maximum allowable operating pressure 450 bar
Filter housing pressure pulse fatigue tested 10⁶ pulses 0-450 bar

Connections

Inlet and outlet connections are threaded internally

Connection style

Thread G1
Thread SAE16
Thread M33, ISO 6149
SAE flange 1»-6000M
SAE flange 1»-6000
Manifold 1»SAE Code 62 Flange Face

Filter housing

Head material cast iron (GSI)
Bowl material steel

Seal material

Nitrile or Fluorelastomer

Operating temperature range

Seal material Nitrile : -40C to +100 C
Seal material Fluorelastomer : -20C to +120 C

Bypass valve & Indicator settings

Bypass	Indicator
3.5 bar	2.5 bar
5.0 bar	4.0 bar
7.0 bar	5.0 bar
Blocked	7.0 bar

Filter element

Degree of filtration
Determined by multipass test in accordance to ISO16889

Flow fatigue characteristics

Filter media is supported so that the optimal fatigue life is achieved (ISO 3724)

Microglass III

Supported with epoxy coated metal wire mesh, end cap material reinforced composite and reusable metal inner core. Collapse pressure 25 bar (ISO 2941)

High collapse elements

To be used when bypass blocked option is selected

Collapse pressure 210 bar (ISO 2941)

Indicator options

Indicating differential pressure:

2.5 +/- 0.3 bar
5.0 +/- 0.3 bar
7.0 +/- 0.3 bar

Visual M3

Electrical T1

Electronic F1 (PNP)

Electronic F2 (NPN)

Atex versions are available on request

Weights (kg)

EPF Size 3 length 1: 6,7
EPF Size 3 length 2: 9,2

Fluid compatibility

- Hydraulic mineral oils H to class HLPD (DIN51524)
- Operating fluids DIN ISO 2943
- Lubrication fluids ISO6743, APJ, DIN 51517, ACEA, ASTM
- Vegetable oils
- 60/40 Water Glycols
- Industrial grade phosphate esters
- Non aggressive synthetic oils
- Non aggressive bio-degradable oils (HETG, HEPG and HEES to VDMA 24568)

EPF *iprotect*® - Size 3 (Inline)

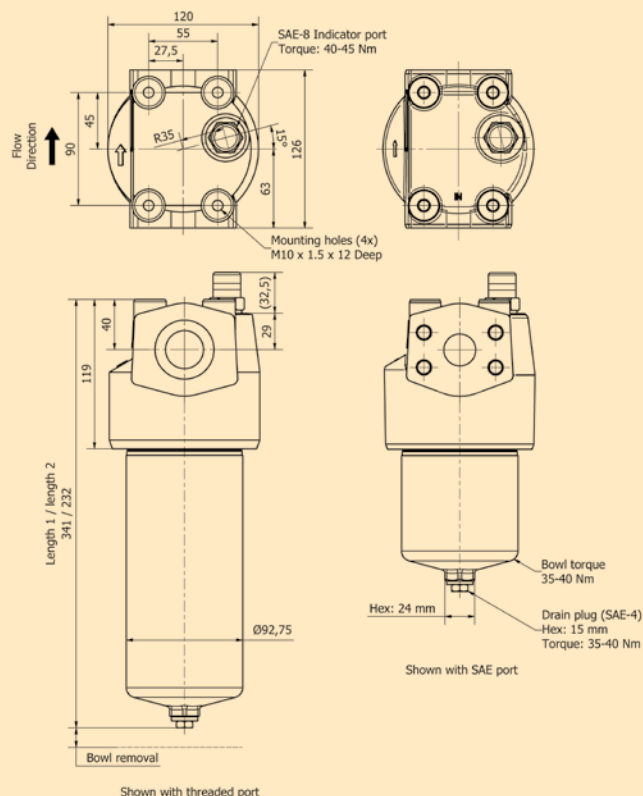

EPF *iprotect*® Size 3 Pressure Drop Curves

With 3.5 bar bypass the recommended initial pressure drop max is 1.2 bar

With 7.0 bar bypass the recommended initial pressure drop max is 2.3 bar

If the medium used has a viscosity different from 30cSt, pressure drop over the filter can be estimated as follows:

The total Δp = housing Δp_h + (element $\Delta p_e \times$ working viscosity/30).

Size 3 L1	EPF Size 3 Length 1 Dp Elements (bar)			
Flow (l/min)	02QI	05QI	10QI	20QI
0	0	0	0	0
50	0.65	0.43	0.26	0.16
100	1.29	0.87	0.53	0.32
150	1.94	1.30	0.79	0.47
200	2.58	1.73	1.05	0.63

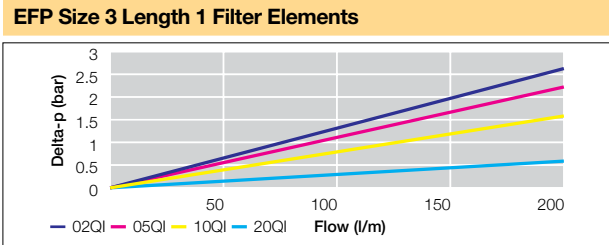

Size 3 L1	EPF Size 3 Length 1 Dp Elements with reverse flow valve (bar)			
Flow (l/min)	02QIR	05QIR	10QIR	20QIR
0	0	0	0	0
50	0.97	0.65	0.39	0.24
100	1.94	1.30	0.79	0.47
150	2.90	1.95	1.18	0.71
200	3.87	2.60	1.58	0.95

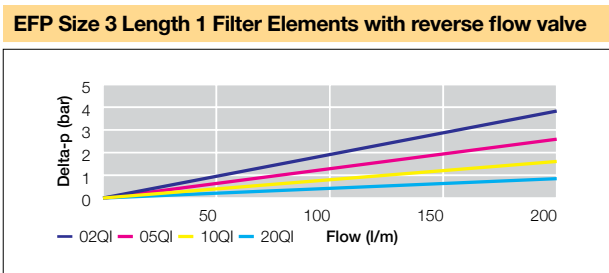

Size 3 L1	Empty Housing (bar)	
Flow (l/min)		Housing
0		0
50		0.06
100		0.17
150		0.3
200		0.47
250		0.64

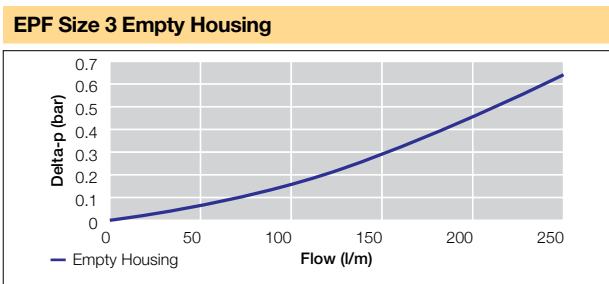

Size 3 L2	EPF Size 3 Length 2 Dp Elements (bar)			
Flow (l/min)	02QI	05QI	10QI	20QI
0	0	0	0	0
50	0.32	0.28	0.18	0.15
100	0.64	0.56	0.37	0.30
150	0.97	0.85	0.55	0.45
200	1.29	1.13	0.74	0.60
250	1.61	1.41	0.92	0.75

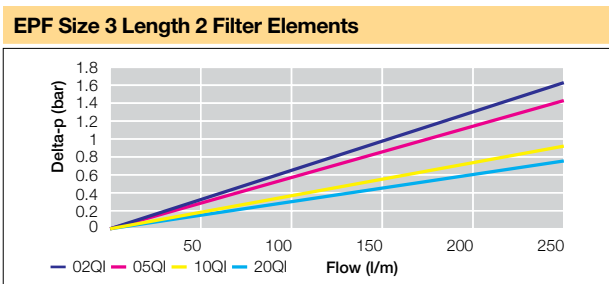

Size 3 L2	EPF Size 3 Length 2 Dp Elements with reverse flow valve (bar)			
Flow (l/min)	02QIR	05QIR	10QIR	20QIR
0	0	0	0	0
50	0.48	0.42	0.28	0.23
100	0.97	0.85	0.55	0.45
150	1.45	1.27	0.83	0.68
200	1.93	1.69	1.10	0.90
250	2.42	2.11	1.38	1.13

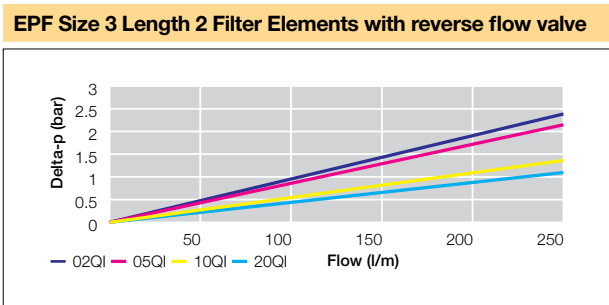

EPF *iprotect*®

Size 4

Specification EPF *iprotect*® Size 4

Specification

Nominal flow >320 l/min

Pressure ratings

Maximum allowable operation pressure 450 bar
Filter housing pressure pulse fatigue tested 10⁶ pulses 0-450 bar

Connections

Inlet and outlet connections are threaded internally

Connection style

Thread G1 1/4»
Thread G1 1/2»
Thread SAE20
Thread SAE24
Thread M42, ISO 6149
SAE flange 11/4»-6000M
SAE flange 11/4»-6000
Manifold 11/4»SAE Code 62 Flange Face

Filter housing

Head material cast iron (GSI)
Bowl material steel
Seal material
Nitrile or Fluorelastomer

Operating temperature range

Seal material Nitrile : -40C to +100 C
Seal material Fluorelastomer : -20C to +120 C

Bypass valve & Indicator settings

Bypass	Indicator
3.5 bar	2.5 bar
5.0 bar	4.0 bar
7.0 bar	5.0 bar
Blocked	7.0 bar

Filter element

Degree of filtration
Determined by multipass test in accordance to ISO16889

Flow fatigue characteristics

Filter media is supported so that the optimal fatigue life is achieved (ISO 3724)

Microglass III

Supported with epoxy coated metal wire mesh, end cap material reinforced composite and reusable metal inner core. Collapse pressure 25 bar (ISO 2941)

High collapse elements

To be used when bypass blocked option is selected
Collapse pressure 210 bar (ISO 2941)

Indicator options

Indicating differential pressure:

2.5 +/- 0.3 bar
5.0 +/- 0.3 bar
7.0 +/- 0.3 bar

Visual M3

Electrical T1

Electronic F1 (PNP)

Electronic F2 (NPN)

Atex versions are available on request

Weights (kg)

EPF Size 4 length 1: 15,8

EPF Size 4 length 2: 20,3

Fluid compatibility

- Hydraulic mineral oils H to class HLPD (DIN51524)
- Operating fluids DIN ISO 2943
- Lubrication fluids ISO6743, APJ, DIN 51517, ACEA, ASTM
- Vegetable oils
- 60/40 Water Glycols
- Industrial grade phosphate esters
- Non aggressive synthetic oils
- Non aggressive bio-degradable oils (HETG, HEPG and HEES to VDMA 24568)

EPF *iprotect*® - Size 4 (Inline)

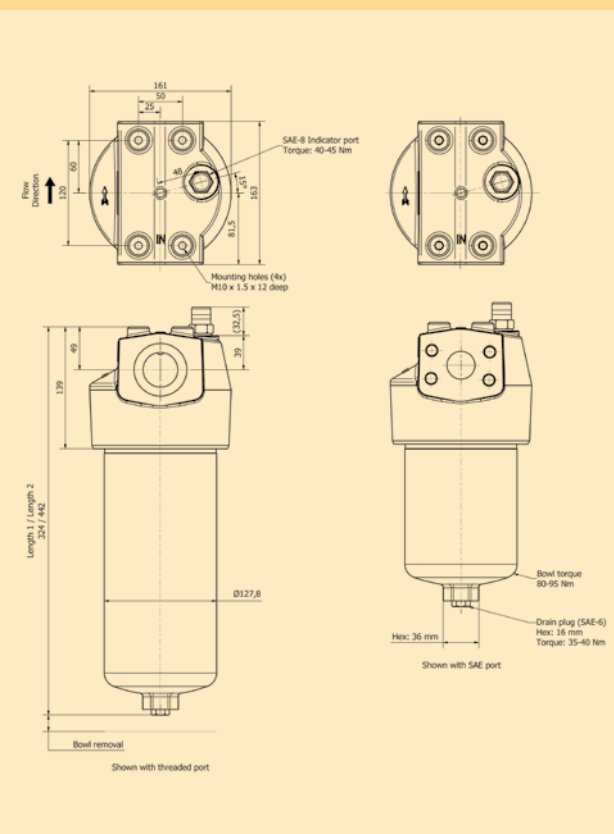

EPF *iprotect*® - Size 4 (Manifold)

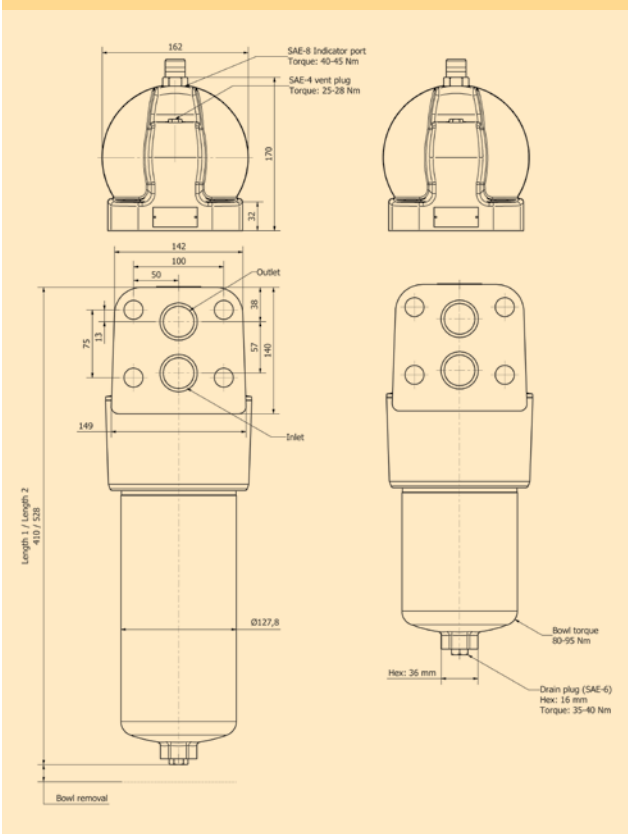

EPF *iprotect*® Size 4 Pressure Drop Curves

With 3.5 bar bypass the recommended initial pressure drop max is 1.2 bar

With 7.0 bar bypass the recommended initial pressure drop max is 2.3 bar

If the medium used has a viscosity different from 30cSt, pressure drop over the filter can be estimated as follows:

The total $\Delta p = \text{housing } \Delta p_h + (\text{element } \Delta p_e \times \text{working viscosity}/30)$.

Size 4 L1	EPF Size 4 Length 1 Filter Elements			
Flow (l/min)	02QI	05QI	10QI	20QI
0	0	0	0	0
100	0.48	0.4	0.26	0.2
200	0.96	0.8	0.52	0.4
300	1.44	1.2	0.78	0.6
400	1.92	1.6	1.04	0.8
500	2.4	2	1.3	1

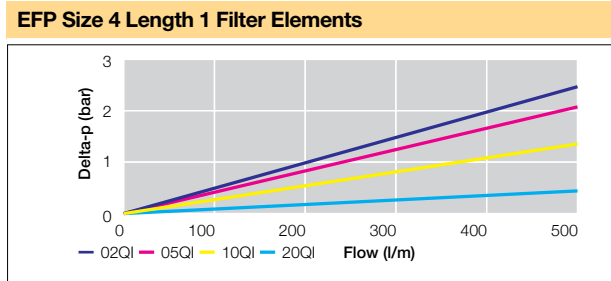

Size 4 L1	EPF Size 4 Length 1 Filter Elements with reverse flow valve			
Flow (l/min)	02QIR	05QIR	10QIR	20QIR
0	0	0	0	0
100	0.72	0.6	0.39	0.3
200	1.44	1.2	0.78	0.6
300	2.16	1.8	1.17	0.9
400	2.88	2.4	1.56	1.2
500	3.6	3	1.95	1.5

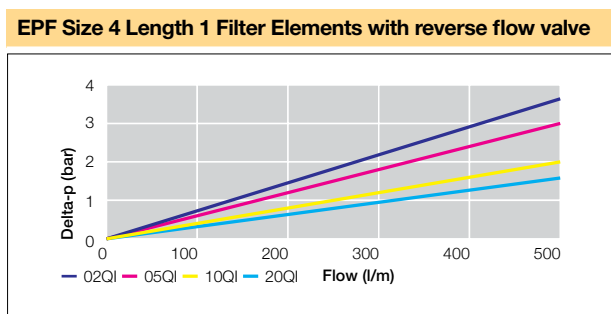

Size 4	EPF Size 4 Empty Housing (bar)
Flow (l/min)	Housing
0	0
100	0.03
200	0.14
300	0.29
400	0.5
500	0.7

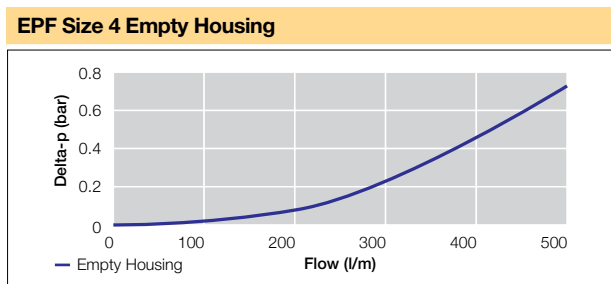

Size 4 L2	EPF Size 4 Length 2 Filter Elements (bar)			
Flow (l/min)	02Q	05Q	10Q	20Q
0	0	0	0	0
100	0.31	0.26	0.176	0.132
200	0.62	0.52	0.352	0.26
300	0.94	0.78	0.528	0.40
400	1.25	1.04	0.704	0.528
500	1.56	1.3	0.88	0.66

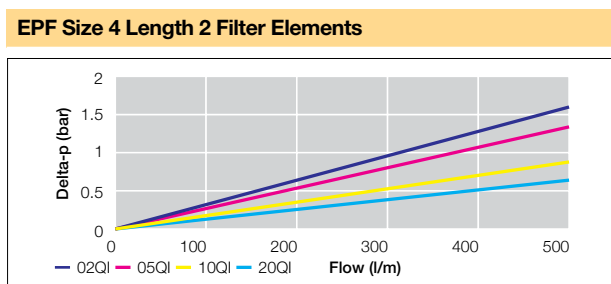

Size 4 L2	EPF Size 4 Length 2 Filter Elements with Reverse Flow Valve			
Flow (l/min)	02Q	05Q	10Q	20Q
0	0	0	0	0
100	0.47	0.39	0.26	0.20
200	0.94	0.78	0.53	0.40
300	1.40	1.17	0.79	0.59
400	1.87	1.56	1.06	0.79
500	2.34	1.95	1.32	0.99

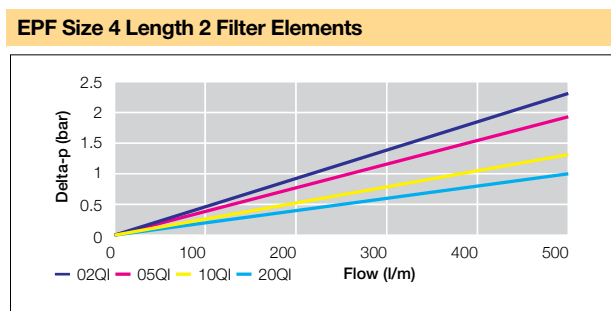

EPF *i*protect®

Size 5

Specification EPF *i*protect® Size 5

Specification

Nominal flow >320 l/min

Pressure ratings

Maximum allowable operationg pressure 450 bar
Filter housing pressure pulse fatigue tested 10⁶ pulses 0-450 bar

Connections

Inlet and outlet connections are threaded internally

Connection style

Thread G11/2»
Thread SAE24
Manifold 11/2»SAE Code 62 Flange Face

Filter housing

Head material cast iron (GSI)
Bowl material steel
Seal material
Nitrile of Fluorelastomer

Operating temperature range

Seal material Nitrile : -40C to +100 C
Seal material Fluorelastomer : -20C to +120 C

Bypass valve & Indicator settings

Bypass	Indicator
3.5 bar	2.5 bar
5.0 bar	4.0 bar
7.0 bar	5.0 bar
Blocked	7.0 bar HEPG and HEES to VDMA 24568)

Filter element

Degree of filtration
Determined by multipass test in accordance to ISO16889

Flow fatigue characteristics

Filter media is supported so that the optimal fatigue life is achieved (ISO 3724)

Microglass III

Supported with epoxy coated metal wire mesh, end cap material reinforced composite and reusable metal inner core. Collapse pressure 25 bar (ISO 2941)

High collapse elements

To be used when bypass blocked option is selected
Collapse pressure 210 bar (ISO 2941)

Indicator options

Indicating differential pressure:

2.5 +/- 0.3 bar
5.0 +/- 0.3 bar
7.0 +/- 0.3 bar

Visual M3

Electrical T1

Electronic F1 (PNP)

Electronic F2 (NPN)

Atex versions are available on request

Weights (kg)

EPF Size 5 length 1: 31

Fluid compatibility

- Hydraulic mineral oils H to class HLPD (DIN51524)
- Operating fluids DIN ISO 2943
- Lubrication fluids ISO6743, APJ, DIN 51517, ACEA, ASTM
- Vegetable oils
- 60/40 Water Glycols
- Industrial grade phosphate esters
- Non aggressive synthetic oils
- Non aggressive bio-degradable oils (HETG, HEPG and HEES to VDMA 24568)

EPF *i*protect® - Size 5 (Inline)

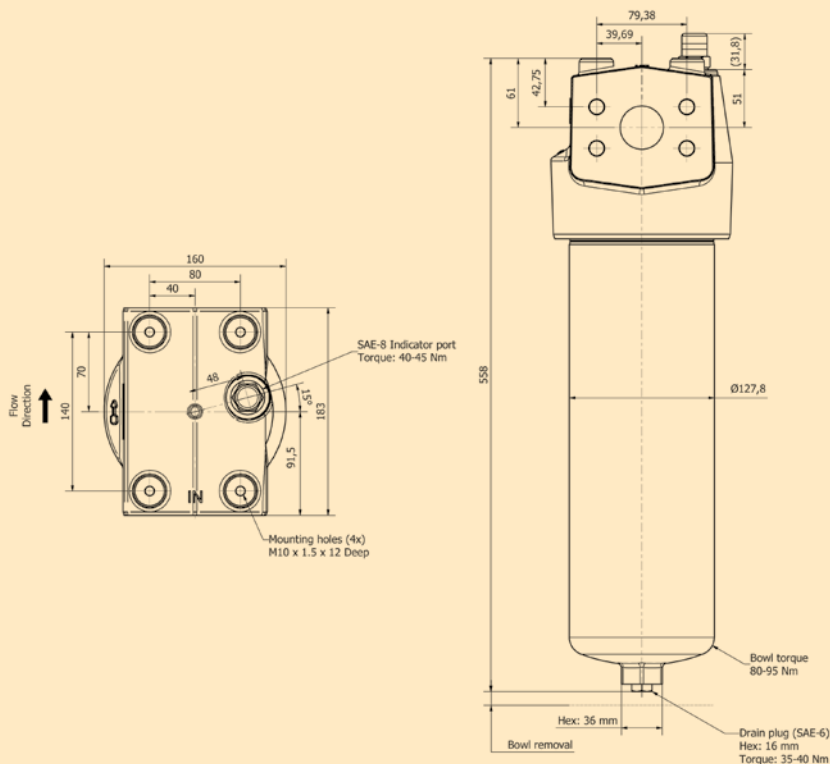

EPF *iprotect*® Size 5 Pressure Drop Curves

With 3.5 bar bypass the recommended initial pressure drop max is 1.2 bar

With 7.0 bar bypass the recommended initial pressure drop max is 2.3 bar

If the medium used has a viscosity different from 30cSt, pressure drop over the filter can be estimated as follows:

The total $\Delta p = \text{housing } \Delta p_h + (\text{element } \Delta p_e \times \text{working viscosity}/30)$.

Size 5	EPF Size 5 Length 1 Filter Elements (bar)			
Flow (l/min)	02QI	05QI	10QI	20QI
0	0	0	0	0
100	0.25	0.21	0.14	0.11
200	0.50	0.42	0.28	0.21
300	0.75	0.62	0.42	0.32
400	1.00	0.83	0.56	0.42
500	1.25	1.04	0.70	0.53
600	1.50	1.248	0.84	0.636
700	1.75	1.456	0.98	0.742

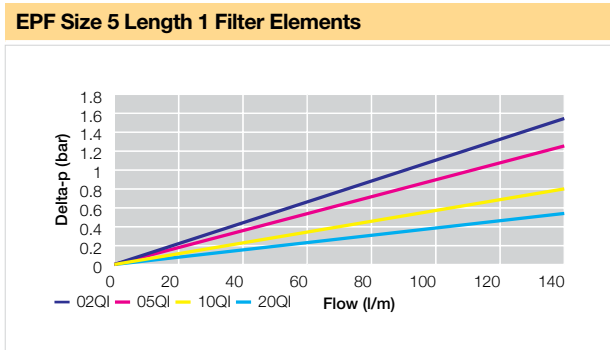

Size 5	EPF Size 5 Empty housing	
Flow (l/min)	Housing	
0	0	
100	0.1	
200	0.2	
300	0.3	
400	0.4	
500	0.51	
600	0.66	
700	0.88	

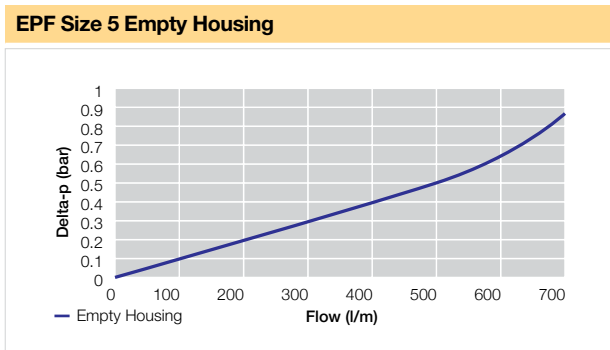

Exploded view spare parts drawing

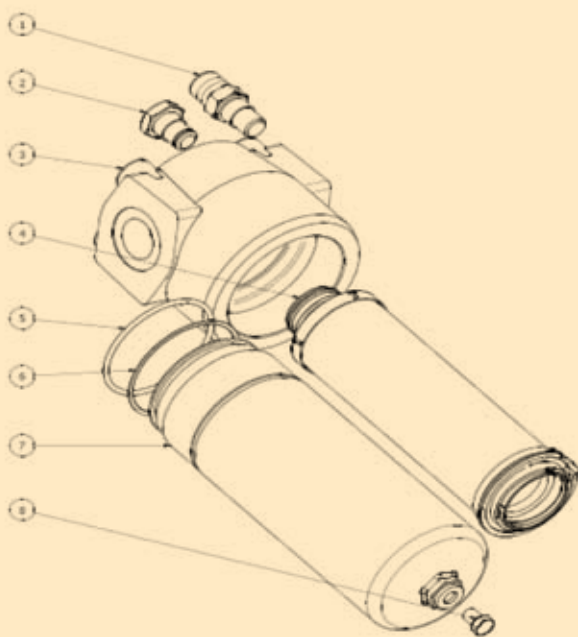

Parts list

Index	Description	Part number
1	Indicator	On Request
2	Plug	On Request
3	Filter head	On Request
4	Filter element	See element table
5	Back-up ring	In seal kit/spare filter elements
6	O-ring	In seal kit/ spare filter elements
7	Filter bowl	On Request
8	Drain plug	On Request

Seal kit numbers

Filter	Nitrile	Fluorelastomer
EPF 1	EPFSK001	EPFSK011
EPF 2	EPFSK002	EPFSK012
EPF 3	EPFSK003	EPFSK013
EPF 4	EPFSK004	EPFSK014
EPF 5	EPFSK005	EPFSK015

Indicator Options

FMU Δp-Indicators and Pressure Indicators

FMUT Electrical

Rated voltage	Non-inductive load (A)				Inductive load (A)				Inrush current (A)	
	Resistive load		Lamp load		Inductive load		Motor load		N.C.	N.O.
	N.C.	N.O.	N.C.	N.O.	N.C.	N.O.	N.C.	N.O.		
125VAC	5	1.5	0.7	3	2.5	1.3	20 max.	10 max.		
250VAC	3	1.0	0.5	2	1.5	0.8				
8VDC	5	2	5	4	3					
14VDC	5	2	4	4	3					
30VDC	4	2	3	3	3					
125VDC	0.4	0.05	0.4	0.4	0.05					
250VDC	0.2	0.03	0.2	0.2	0.03					

Enclosure class	IP65
Electrical connector	DIN 43650
Overvoltage category	II (EN61010-1)

Contact configuration

Electrical Indicator Type T1

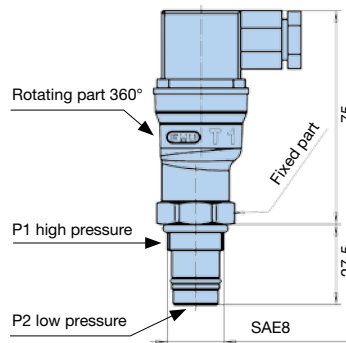
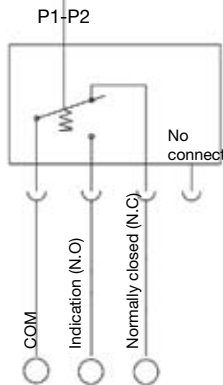

FMUM3 Visual Auto Reset Operation

Red colour visible when indicator on

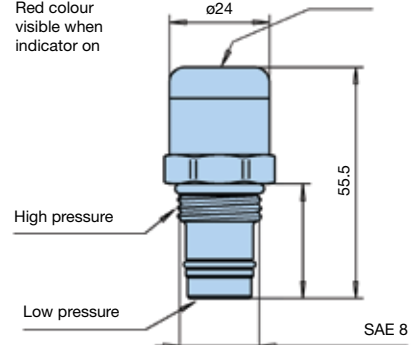

FMUF Electronic

Contact configuration

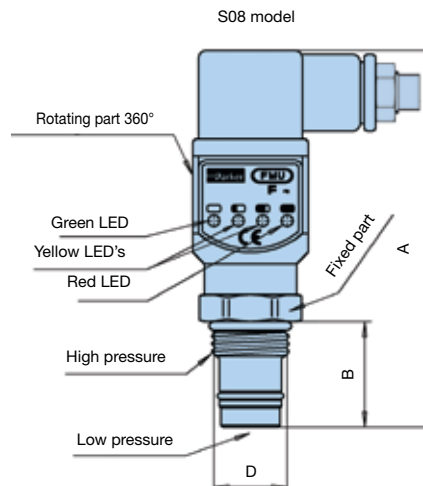
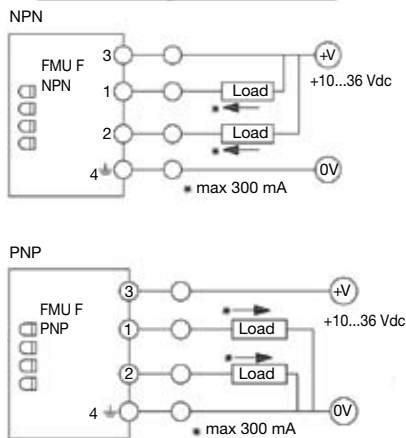

	S08
A	105
B	ø18.83 ± 0.06
D	SAE 8

Thermal lock-out (standard setting +20°C)

- Indicator operates only when temperature is above setting.
- Green LED is blinking if temperature is lower. (not in U12H)

Ind. press. setting	LED status				Output
	G	Y1	Y2	R	
< 50 %	⊗				-
50 %	⊗	⊗			-
75 %	⊗	⊗	⊗		2 active
100 %	⊗	⊗	⊗	⊗	1 active

Enclosure class	IP65
Electrical connector	DIN 43650, cable connection PG9 or optionally M12 4-pin
Input supply voltage	+10 to 36 Vdc
*Indication output	max. 300 mA/36 Vdc
Output type:	N.O. or N.C./NPN or PNP

Note: Do not connect output terminals 1 or 2 directly (without load) to power supply terminals, because this will damage the equipment.

Filter media efficiency

Degree of filtration						Code	
Average filtration beta ratio β (ISO 16889) / particle size μm [c]							
$\beta_x(c)=2$	$\beta_x(c)=10$	$\beta_x(c)=75$	$\beta_x(c)=100$	$\beta_x(c)=200$	$\beta_x(c)=1000$		
% efficiency, based on the above beta ration (β_x)						Disposable Microglass III	Element with reverse flow valve
50.0%	90.0%	98.7%	99.0%	99.5%	99.9%		
N/A	N/A	N/A	N/A	N/A	4.5%	02QI	02QIR
N/A	N/A	4.5	5	6	7	05QI	05QIR
N/A	6	8.5	9	10	12	10QI	10QIR
6	11	17	18	20	22	20QI	20QIR

Ordering information. Standard part numbers

Filter Assemblies	Part Number	Flow (l/min)	Model Number	Element length	Media Rating (micron)	Seals	Indicator	Bypass (bar)	Ports	Replacement elements
	EPF1105QLBPMG081	40	EPF1	1	5	Nitrile	Plugged port	7	G1/2"	944419Q
	EPF1110QLBPMG081	40	EPF1	1	10	Nitrile	Plugged port	7	G1/2"	944420Q
	EPF1120QLBPMG081	40	EPF1	1	20	Nitrile	Plugged port	7	G1/2"	944421Q
	EPF2205QLBPMG121	140	EPF2	2	5	Nitrile	Plugged port	7	G3/4"	944431Q
	EPF2220QLBPMG121	140	EPF2	2	10	Nitrile	Plugged port	7	G3/4"	944432Q
	EPF2220QLBPMG121	140	EPF2	2	20	Nitrile	Plugged port	7	G3/4"	944433Q
	EPF3205QLBPMG161	250	EPF3	2	5	Nitrile	Plugged port	7	G1"	944439Q
	EPF3220QLBPMG161	250	EPF3	2	10	Nitrile	Plugged port	7	G1"	944440Q
	EPF3220QLBPMG161	250	EPF3	2	20	Nitrile	Plugged port	7	G1"	944441Q
	EPF4205QLBPMG201	450	EPF4	2	5	Nitrile	Plugged port	7	G11/4"	944447Q
	EPF4210QLBPMG201	450	EPF4	2	10	Nitrile	Plugged port	7	G11/4"	944448Q
	EPF4220QLBPMG201	450	EPF4	2	20	Nitrile	Plugged port	7	G11/4"	944449Q
	EPF5105QLBPMG241	500	EPF5	1	5	Nitrile	Plugged port	7	G11/2"	944451Q
	EPF5110QLBPMG241	500	EPF5	1	10	Nitrile	Plugged port	7	G11/2"	944452Q
	EPF5120QLBPMG241	500	EPF5	1	20	Nitrile	Plugged port	7	G11/2"	944453Q

Visuals Indicators	Part Number	Setting (bar)	Switch Type	Additional
	FMUM3MVMS08	5	Not applicable	1

Electrical Indicators	Part Number	Setting (bar)	Switch Type	Additional
	FMUT1MVMS08	5	NO/NC	
	FMUF1MVMS08	5	NO	Electronic 4 LED, PNP
	FMUF2MVMS08	5	NO	Electronic 4 LED, NPN
	FMUF3MVMS08	5	NC	Electronic 4 LED, PNP
	FMUF4MVMS08	5	NC	Electronic 4 LED, NPN

Spare elements

EPF Size1 L1 2 micron	944418Q
EPF Size1 L1 5 micron	944419Q
EPF Size1 L1 10 micron	944420Q
EPF Size1 L1 20 micron	944421Q
EPF Size1 Customer Special	944422Q
EPF Size1 Customer Special	944423Q
EPF Size1 Customer Special	944424Q
EPF Size1 Customer Special	944425Q
EPF Size 2 L1 2 micron	944426Q
EPF Size 2 L1 5 micron	944427Q
EPF Size 2 L1 10 micron	944428Q
EPF Size 2 L1 20 micron	944429Q

EPF Size 2 L2 2 micron	944430Q
EPF Size 2 L2 5 micron	944431Q
EPF Size 2 L2 10 micron	944432Q
EPF Size 2 L2 20 micron	944433Q
EPF Size 3 L1 2 micron	944434Q
EPF Size 3 L1 5 micron	944435Q
EPF Size 3 L1 10 micron	944436Q
EPF Size 3 L1 20 micron	944437Q
EPF Size 3 L2 2 micron	944438Q
EPF Size 3 L2 5 micron	944439Q
EPF Size 3 L2 10 micron	944440Q
EPF Size 3 L2 20 micron	944441Q

EPF Size 4 L1 2 micron	944442Q
EPF Size 4 L1 5 micron	944443Q
EPF Size 4 L1 10 micron	944444Q
EPF Size 4 L1 20 micron	944445Q
EPF Size 4 L2 2 micron	944446Q
EPF Size 4 L2 5 micron	944447Q
EPF Size 4 L2 10 micron	944448Q
EPF Size 4 L2 20 micron	944449Q
EPF Size 5 L1 2 micron	944450Q
EPF Size 5 L1 5 micron	944451Q
EPF Size 5 L1 10 micron	944452Q
EPF Size 5 L1 20 micron	944453Q

Ordering Information

Product Configurator

Box 1	Box 2	Box 3	Box 4	Box 5	Box 6	Box 7	Box 8
EPF3	2	02QI	B	F2	M	G16	1

Box 1

Capacity	
Model	Code
Size 1 (40 l/min)	EPF1
Size 2 (replaces 18P)	EPF2
Size 3 (replaces 28P)	EPF3
Size 4 (replaces 38P)	EPF4
Size 5	EPF5

Box 2

Filter Length	
Length 1	Code
Length 1	1
Length 2 (not for Size 1 and Size 5)	2

Highlights Key (Denotes part number availability)

123
123
123
123

Box 3

Degree of filtration				
Media code				
iprotect® Glassfibre element	02QI	05QI	10QI	20QI
iprotect® with reverse flow valve(*)	02QIR	05QIR	10QIR	20QIR

(*Note: Only in combination with 3.5 bar bypass)

Box 4

Seal Material	
	Code
Nitrile	B
Fluorelastomer	V

Box 5

Indicator	
	Code
Visual Indicator	M3
Electrical Indicator	T1
Electronic 4 LED, PNP, NO	F1
Electronic 4 LED, NPN, NO	F2
Electronic 4 LED, PNP, NC	F3
Electronic 4 LED, NPN, NC	F4
Plugged with Steel plug	P
No indicator port	N

Other versions like ATEX on request
All electrical indicators are CE-certified

Box 6

Bypass Setting		
	Indicator Setting	Code
3.5 bar	2.5 bar	K
5.0 bar	4.0 bar	L
7.0 bar	5.0 bar	M
No bypass	5.0 bar	P
No bypass	No indicator	X

Important notes: When no bypass is selected Parker strongly advises the usage of high strength elements

Box 8

Options		
		Code
Standard		1
No bypass		2
Reverse flow valve	Safeguard valve only in combination with 3.5 bar bypass	RFV

Box 7

Filter Connection			
	Connection type & size	Code	
Size 1	Thread G1/2"	G08	
	SAE-8 ports		
Size 2	Thread G3/4"	G12	
	Thread SAE12	S12	
	Thread M27, ISO 6149	M27	
	SAE flange 3/4"-6000M	H12	
	SAE flange 3/4"-6000	F12	
	Manifold	X12	
Size 3	Thread G1	G16	
	Thread SAE16	S16	
	Thread M33, ISO 6149	M33	
	SAE flange 1"-6000M	H16	
	SAE flange 1"-6000	F16	
	Size 4	Thread G11/4"	G20
		Thread G11/2"	G24
Thread SAE20		S20	
Thread SAE24		S24	
Thread M42, ISO 6149		M42	
SAE flange 11/4"-6000M		H20	
SAE flange 11/4"-6000		F20	
Size 5	Manifold	X20	
	Thread G11/2"	G24	
	Thread SAE24	S24	
	Manifold 11/2"SAE Code 62 Flange Face	Y24	
	Manifold	X24	



Parker Hannifin Ltd.

Free phone (EPIC): 00 800 27 27 5374

Email: filtrationinfo@parker.com

www.parkerhfde.com