

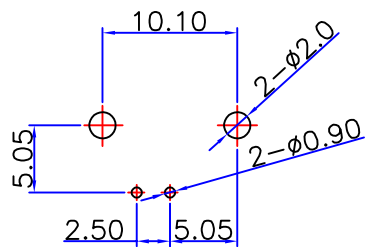

PRODUCT NO:		DOSIN-801-0034		
REV	DESCRIPTION	DWN	DATE	APPROVEN
A	FIRST ISSUE	JIM	2012/11/02	John kine
B	以实物尺寸更新	W.cheng	2020/07/18	John kine

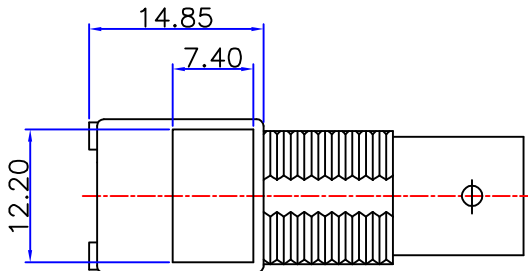
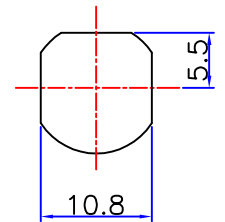
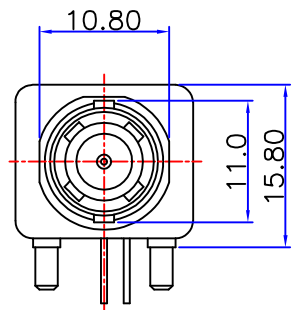
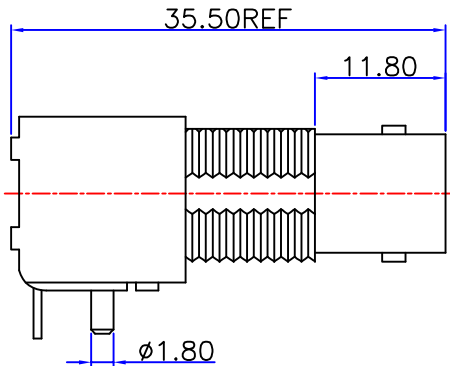
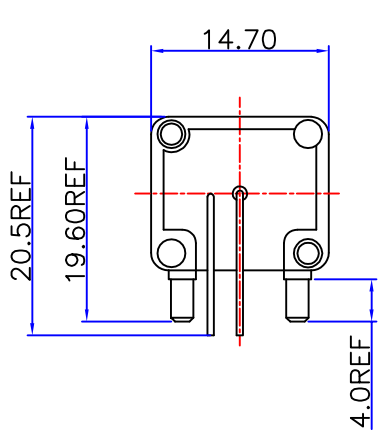

SPECIFICATIONS:

IMPEDANCE: 50 ohms
 FREQUENCY RANGE: DC~3G
 VSWR: 1.3MAX
 WORKING VOLTAGE: 500V RMS@SEA LEVEL
 INSULATION RESISTANCE: 5000 ohms min
 TEMPERATURE RANGE: -55°C TO +155°C
 RELATIVE HUMIDITY: ≤ 95%(40°C±2°C)
 DRAWINGS PRODUCTS ARE IN LINE WITH ROHS STANDARDS

RECOMMENDED PCB LAYOUT

1	BODY	ZINC	NICKEL	1
2	CONTACT PIN	BRASS	GOLD	1
3	INSULATOR	POM	WHITE	1
4				
5				
6				
7				
8				
9				
10				
NO	COMPONENT NUMBER	MATERIAL	FINISH	QTY

NOTE:	
DRAWN	2020/07/18
CHECKED	
APPROVALS	

TOIERANCE	UNLESSOTHERWISPECIFIED TOLERANCESFDRINCHESARE 0.5-8MM±0.020MM 8-30MM±0.40MM 30-120MM±0.50MM
VIEW	
UNIT	MM
SCALE	1 : 1

DOSIN INDUSTRIAL(HK)CO.,LTD 东莞市德索五金电子有限公司 Dongguan Dosin Hardware Electronics Co.,Ltd.		Web: http://www.dosinconn.com dosin2005@dosin-china.com E-mail: dosin2005@163.com Tel: (0086)769-81153906 Fax: (0086)769-81875836
NAME: BNC JACK CONNECTOR DNN		
SIZE A	PRODUCT NO: DOSIN-801-0034	SIZE A
DATE TIME	CAD FILE	SHEET: 1 OF 1
2020/07/18	D/companydrawings/BD	