

COUNT	DESCRIPTION OF REVISIONS	BY	CHKD	DATE	COUNT	DESCRIPTION OF REVISIONS	BY	CHKD	DATE
△				..	△				..
△				..	△				..
△				..	△				..

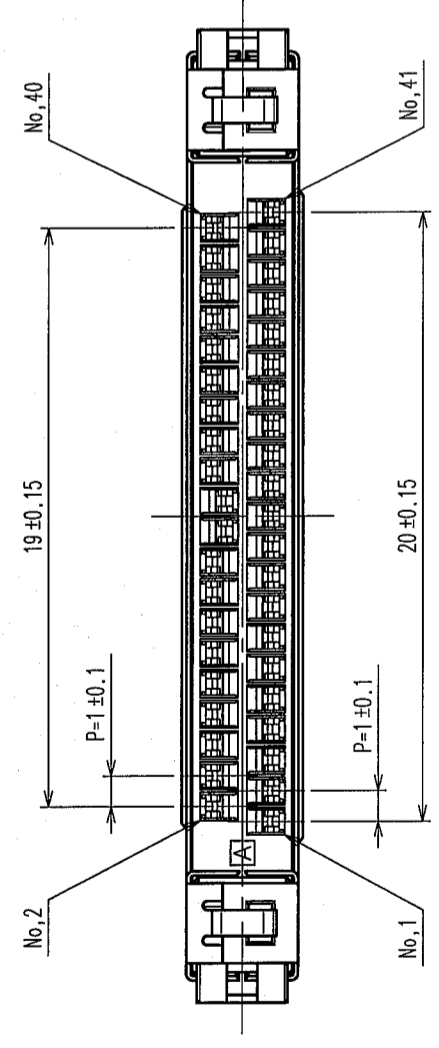
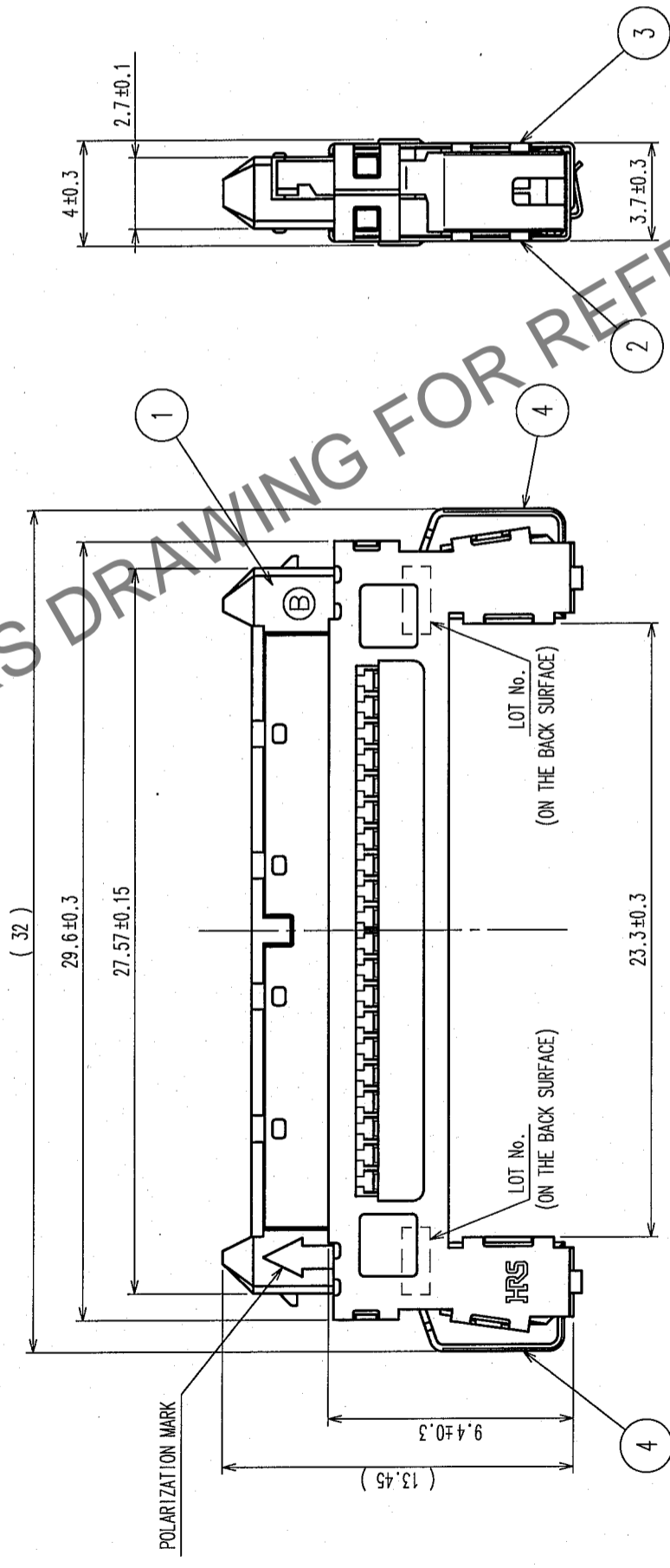
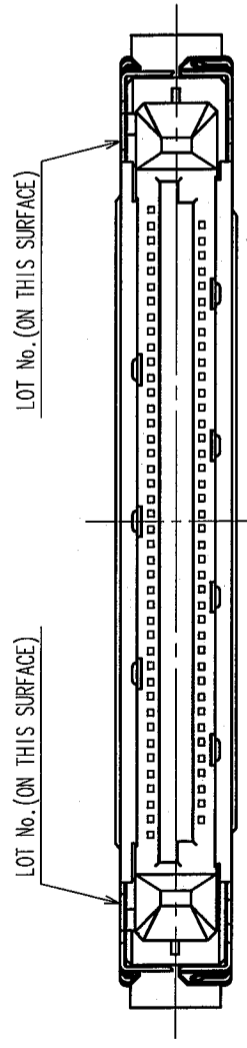

NOTE 1. The lot no. is marked on right and left areas of the indicated surface.
 2. () indicates a reference dimension.
 3. The connectors are delivered in tray packaging.
 Refer to the package specification drawing on Sheet 2 for details.

2	NICKEL SIRVER	4	STAINLESS		
1	PA BLACK UL94V-0	3	NICKEL SIRVER		
NO.	MATERIAL	FINISH, REMARKS	NO.	MATERIAL	FINISH, REMARKS
CODE NO. (OLD)		CL	DRAWN		DESIGNED
			K.SHIBUYA		K. Shibusawa
			05.08.31		05.08.31
					05.09.01
					05.09.01
DRAWING NO.		EDC3-155938		PART NO.	
SCALE		4 : 1		FX15S-41P-C	
UNITS		mm		CODE NO.	
				CL575-2107-9	
				1 / 4	

TO	

COUNT		DESCRIPTION OF REVISIONS		BY	CHKD	DATE	COUNT		DESCRIPTION OF REVISIONS		BY	CHKD	DATE
△	△						△	△					
△	△						△	△					

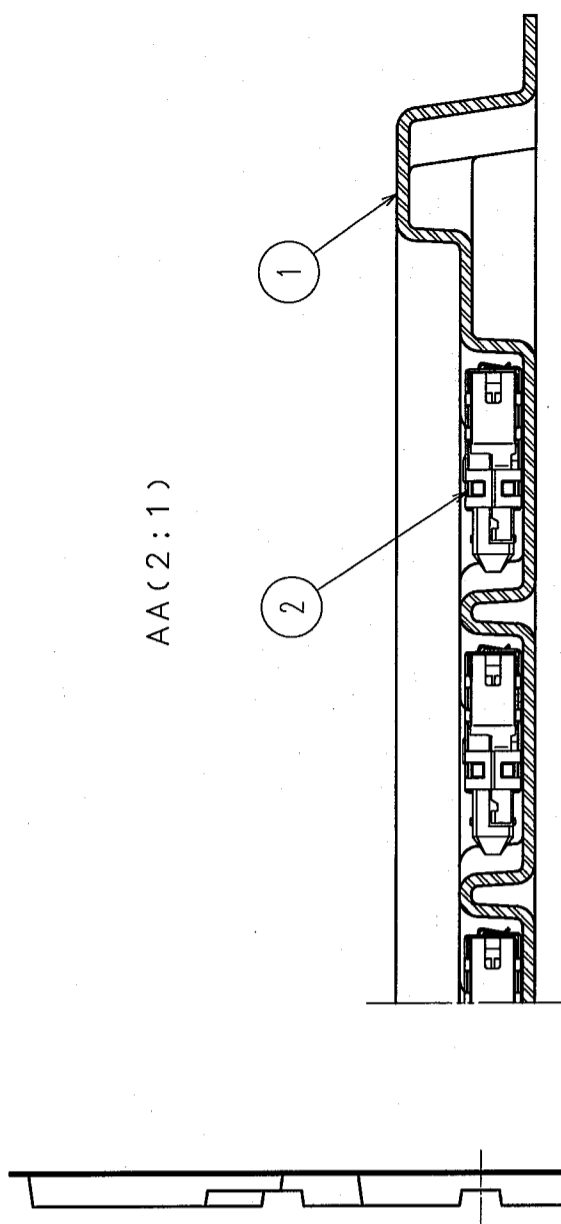
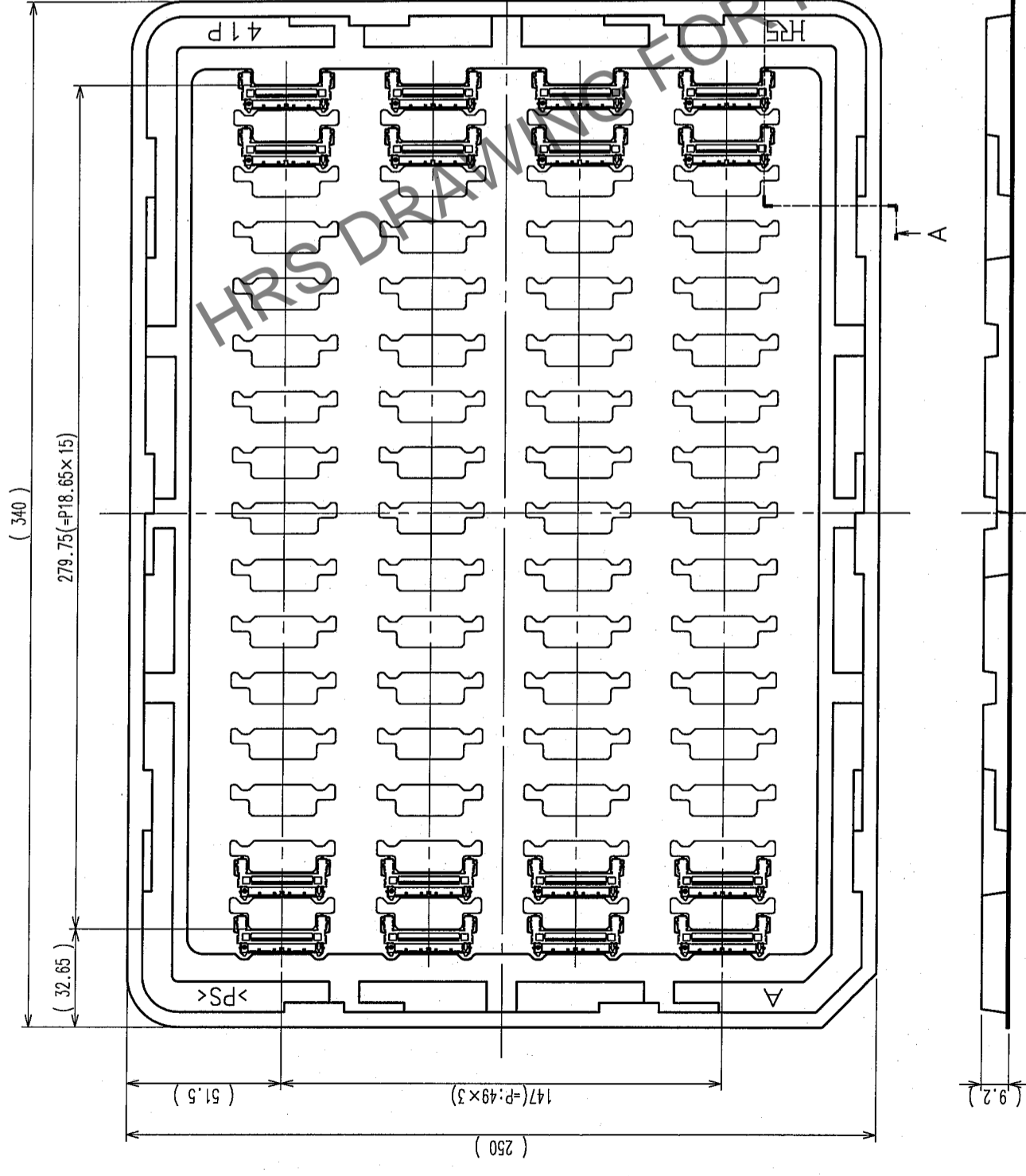

NOTE 1. One tray contains 64 connectors.
 2. Connectors are arranged in tray packaging as shown in the figure.
 However, either connector surface can be the top.
 3. () indicates a reference dimension.

TO	

1		TRAY		CONNECTOR	
NO.	MATERIAL	FINISH, REMARKS	NO.	MATERIAL	FINISH, REMARKS
1	PS CL		2		
CODE NO. (OLD)		DRAWN		DESIGNED	
CL		K.SHIBUYA 05.08.31		K.Shibuya 05.08.31	
DRAWING NO.		PART NO.		APPROVED	
EDC3-155938		FX15S-41P-C		H. Okawa 05.09.01	
SCALE		CODE NO.		RELEASED	
1 : 2		CL575-2107-9			
UNITS		HIROSE ELECTRIC CO., LTD			
mm					

COUNT	DESCRIPTION OF REVISIONS	BY	CHKD	DATE	COUNT	DESCRIPTION OF REVISIONS	BY	CHKD	DATE
△					△				
△					△				
△					△				

◆ After mating
Carefully wire cables, so that excessive force will not be applied to the mated connectors. Especially, pulling a single cable with the force of 5 N or more may cause the cable (crimped contact) to fall out. Also, pulling a whole set of cables with the force of 20 N or more may damage the connectors. Take a caution to avoid pulling the cables.

◆ Withdrawal from on-board connector
The connectors are locked while they are mated. In order to unmate the connectors, pull the connector straight, with releasing the lock by pushing both sides of the connector. At this time, do not pull the cables. Also, avoid the withdrawal in angle, which may damage the connectors.

< Proper withdrawal >

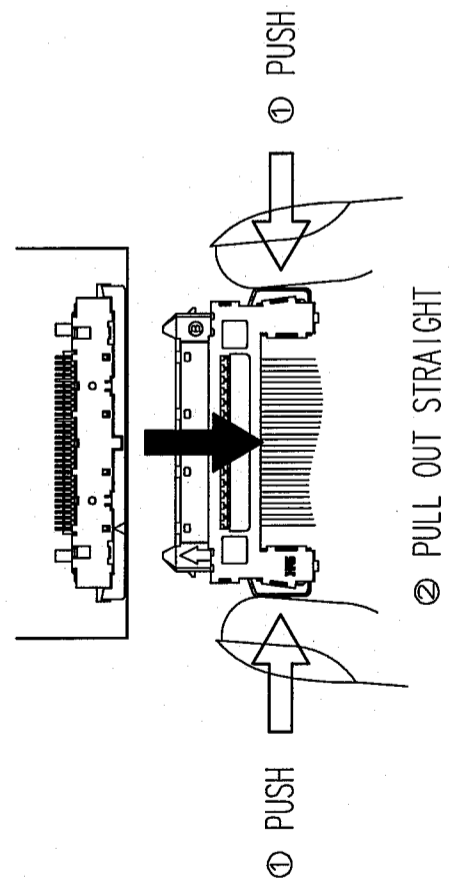

< Improper withdrawal >

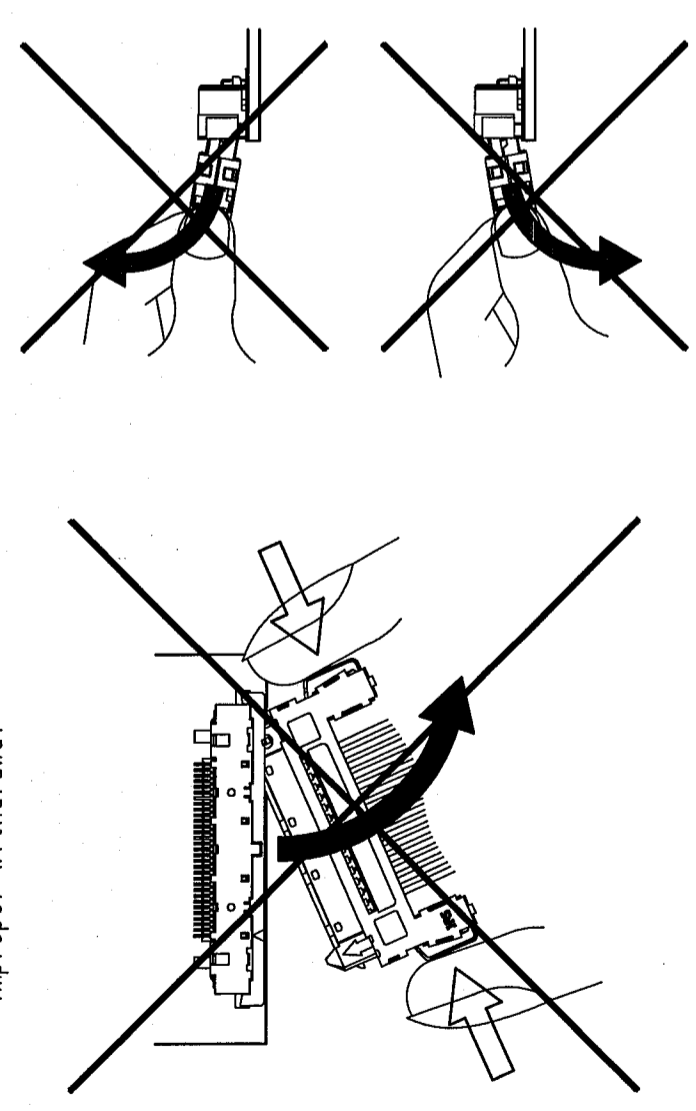

Cautions for soldering

- ◆ Grounding method of cable shield
The cable shield and ground wire can be connected to the connector by soldering. Make sure to solder properly, following the cautions below.
1. Solder the wire to the connector at the recommended area.
Note that the soldering out of the recommended area may effect the product performance.
 2. Follow the temperature of the soldering tip and the time of soldering specified in the product specification sheet.
 3. Avoid applying excessive stress to the connector during soldering with the soldering tip.
 4. Take a caution for the flux desortion from wire soldering.
The flux attached at the contact area may cause a contact failure.

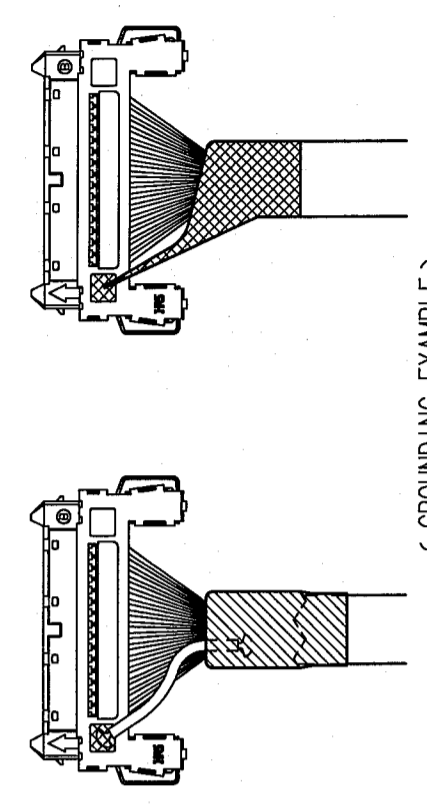
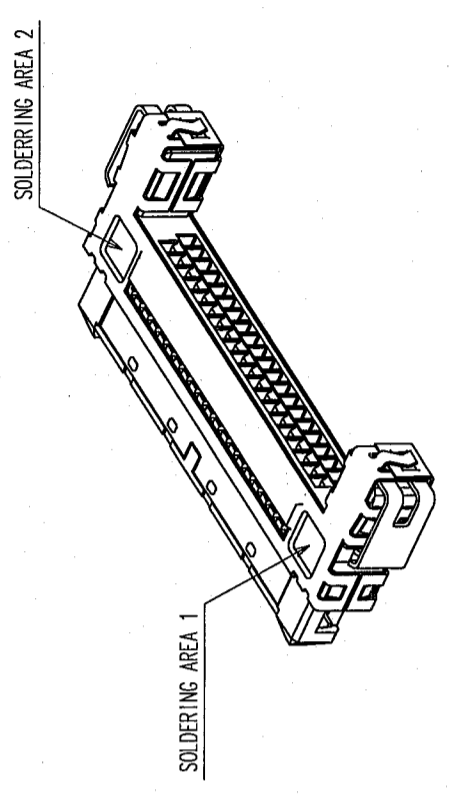

Note: The connectors shown in this "INSTRUCTION MANUAL" are drawn for the instruction purpose, therefore, the appearance differs from the actual connectors. Please confirm the connector configuration on the connector drawing (SHEET 1).

NO.	MATERIAL	FINISH, REMARKS	NO.	MATERIAL	FINISH, REMARKS
CL					
INSTRUCTION MANUAL			DRAWN	DESIGNED	CHECKED
			K. SHIBUYA	K. Shibuya / H. Yamaguchi / H. Okawa	APPROVED
			05.08.31	05.08.31 / 05.09.01	RELEASED
DRAWING NO.		PART NO.			
EDC3-155938		FX15S-41P-C			
SCALE	4 : 1	UNITS			
ITTM		CODE NO.			
		CL575-2107-9			

