



## Tangshan Guoxin Jingyuan Electronics Co.,Ltd

Add: Xinxing Electronics Industrial Park, Yutian,Tangshan,Hebei,China

TEL: 86-315-6118243

E-mail: [sales@jingyuan.com](mailto:sales@jingyuan.com)

FAX: 86-315-6113576

Web : [www.jingyuan.com](http://www.jingyuan.com)

### APPROVAL SHEET

Customer : \_\_\_\_\_

Part Number : \_\_\_\_\_

JYEG P/N : JYGD3

Holder : SMD3225 GLASS

Frequency : 12.000~55.46667MHZ

Manufacturer : Guoxin Jingyuan Electronics

Date : 2025/12/30

Prepared	Checked	Approved
Huang Mingxing	Yang Tiesheng	Zhang Liqiang

(For Customer Use)

Acceptable	Non-Acceptable



1.This specification applies to SMD quartz crystal unit with a frequency of 12.000~55.46667MHz.

## 2. Electrical characteristics

ITEM/TYPE	SMD3225 GLASS
Frequency Range	12.000~55.46667MHz
Mode of Vibration	Fundamental
Frequency Tolerance (at 25°C)	±15ppm,or specify
Frequency Stability Over Operating Temperature Range	±30ppm/-40~85°C, ±50ppm, ±100ppm/-40~125°C, or specify
Shunt Capacitance	3pF Max.
Load Capacitance	6~50pF or Series
Resonance Resistance	As per below table1.
Drive Level	300μW Max.
Aging	±3ppm/year
Insulation Resistance	500MΩ@DC100V
Storage Temperature Range	-55~125°C

Frequency	Resonance Resistance
12.000~20.000MHz	80Ω Max.
20.000~40.000MHz	45Ω Max.
40.000~55.46667MHz	30Ω Max.

**3. Construction**

3.1 Crystal enclosure seal:

- Seam seal
- resistance weld
- cold weld

3.2 crystal enclosure medium

- nitrogen
- vacuum
- dry air

**4.Dimension:**

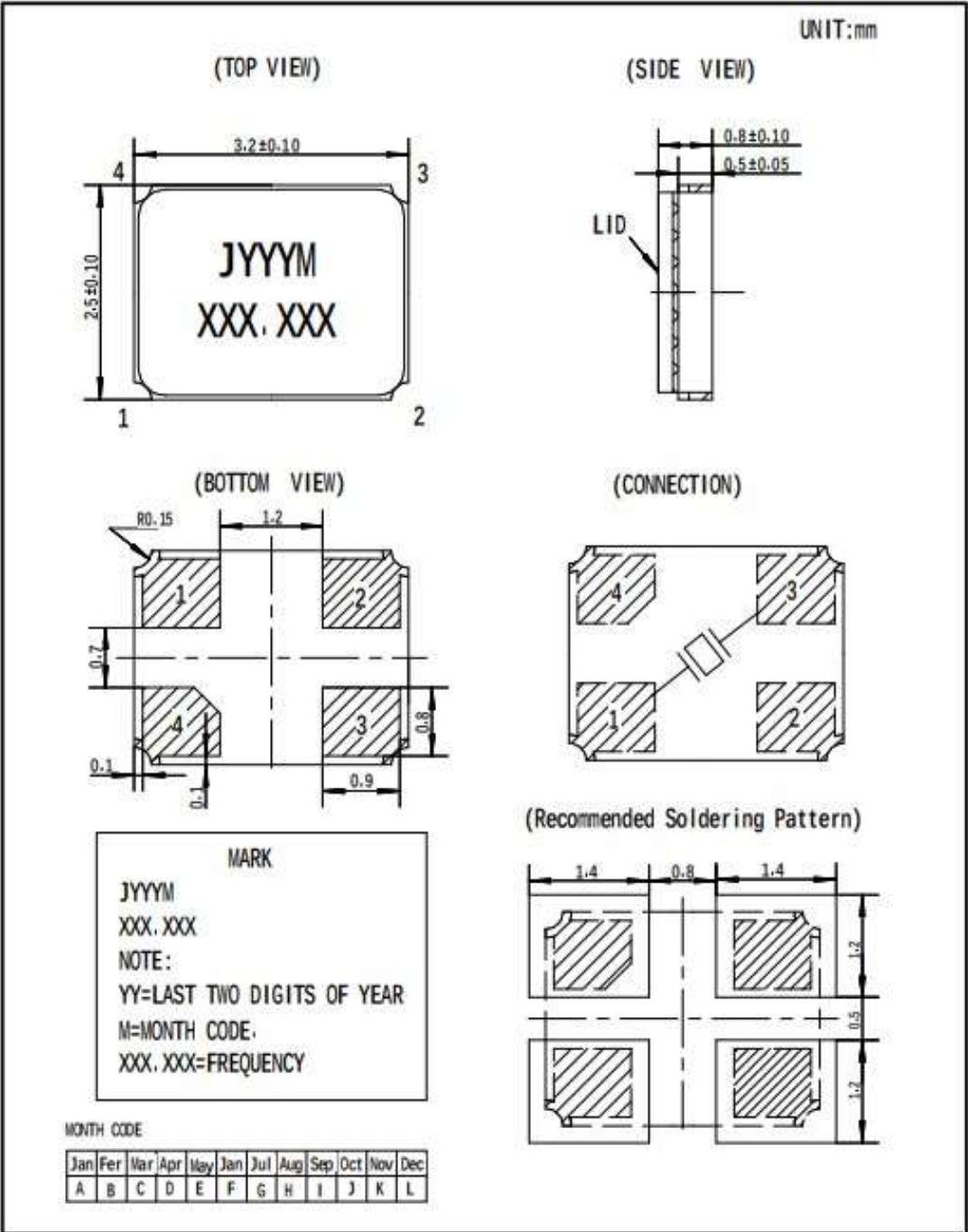

**5. Marking**

- Laser Marking
- Ink Marking

## 6. Inside Structure

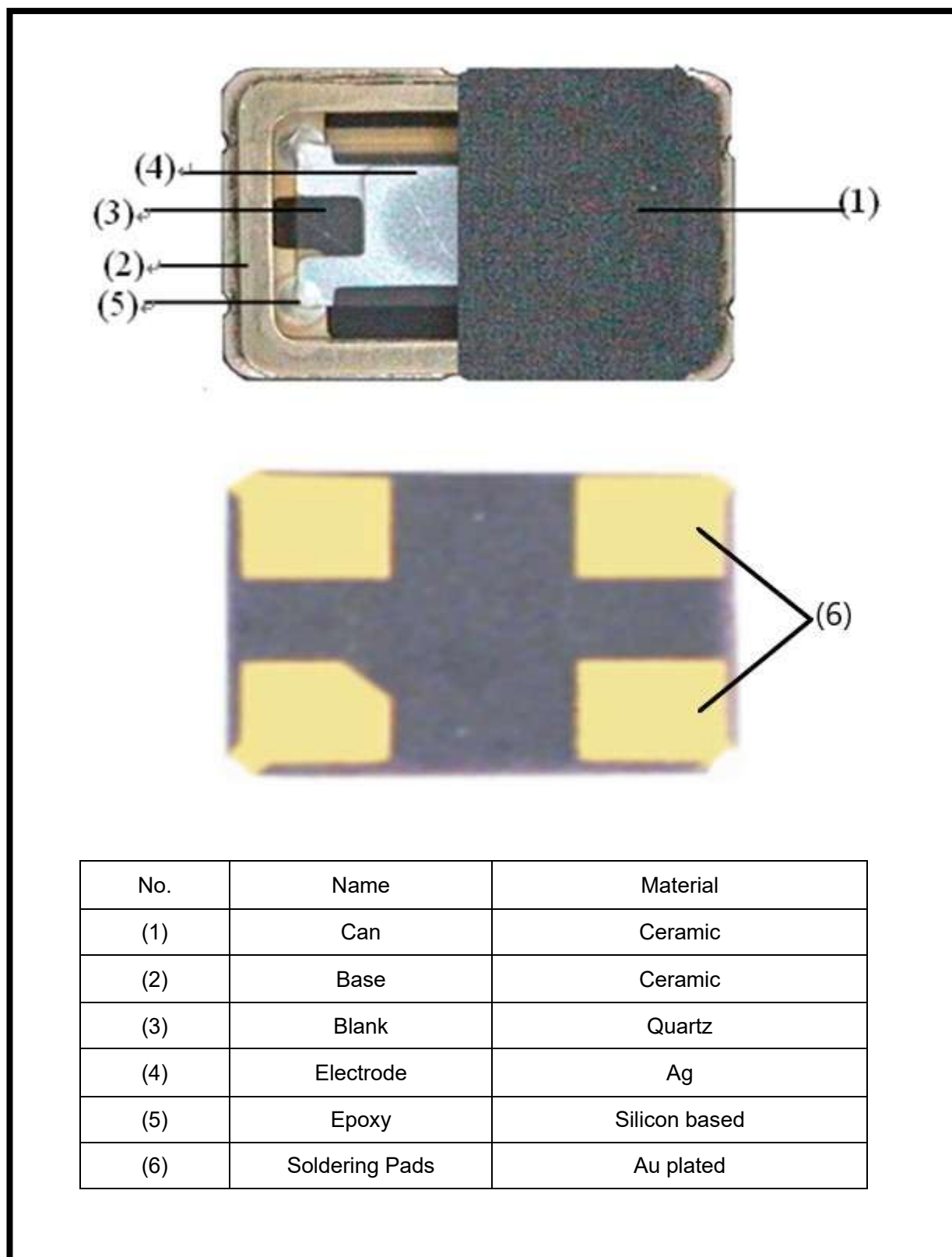

### 7.Taping Dimension and Packing Instruction

#### 7.1

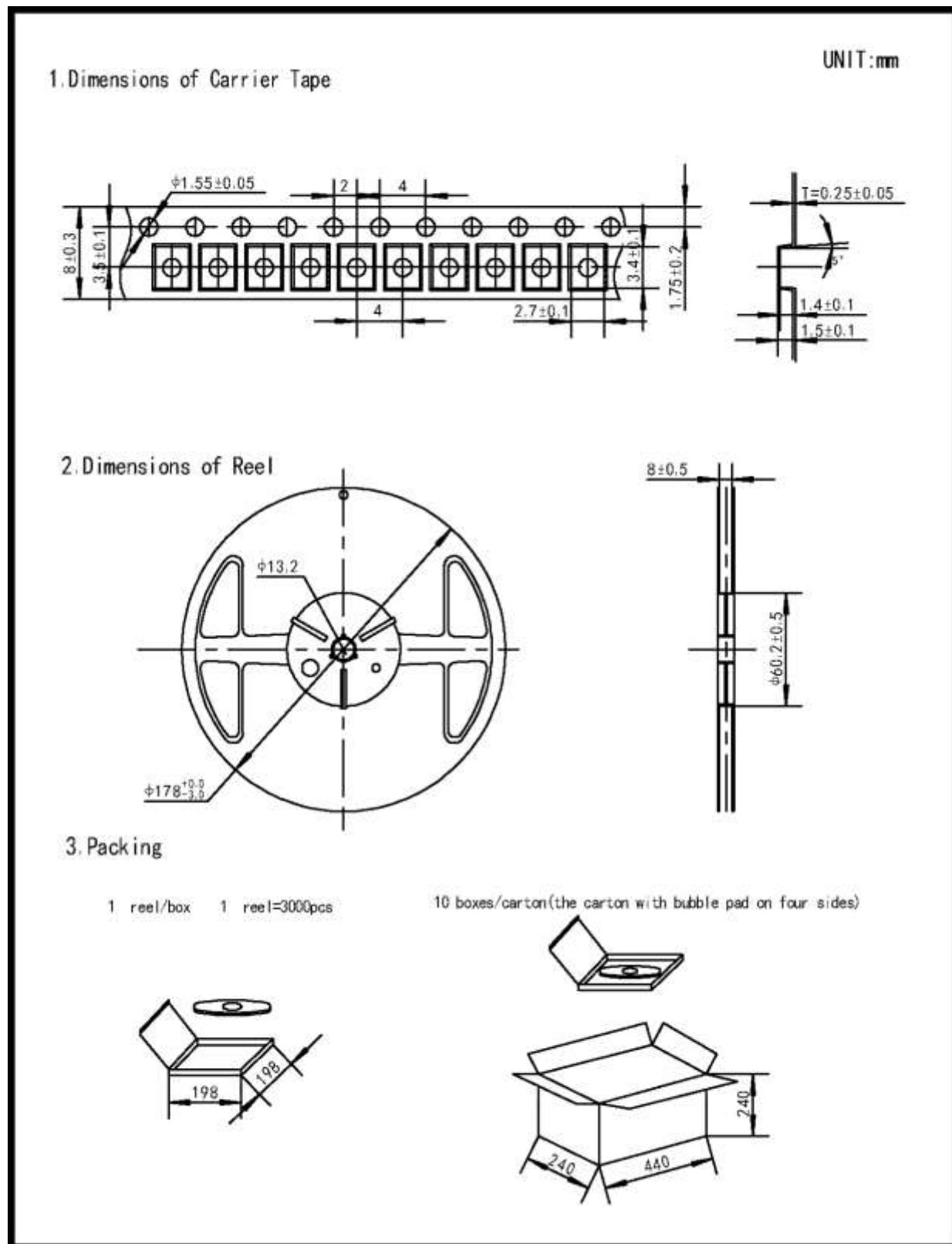

7.2

## Release strength of cover tape

It has to be between 30g to 90g under following condition.

Pulling direction : 165 deg. to 180 deg.

Speed : 300mm/min.

Otherwise unless specified.

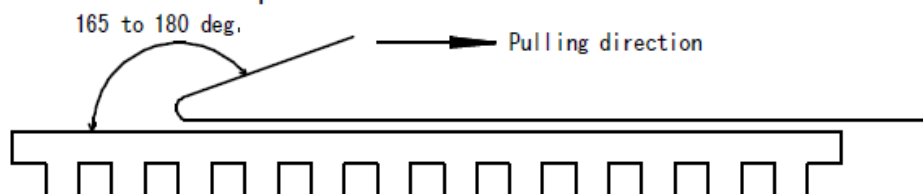

## 8. Reliability characteristic:

NO	Item	Condition	Specifications	Reference
8.1	High Temperature Exposure (Storage) 高温存储	1000 hrs. at rated operating temperature and powered. Measurement at 24±2 hours after test conclusion. 元件就贮存在 85°C 下 1000 小时，在试验结束后 24±2 小时测试。	$\Delta F/F_0 \leq \pm 10\text{ppm}$ ESR ≤ 5Ω or 20%	MIL-STD-202 Method 108
8.2	Temperature Cycling 温度循环	-40° C to 125°C part the 1000 cycles will be at that perature rating. Measurement at 24 ± 2 hours after test conclusion. 30min maximum dwell time at each temperature extreme. 1 min. maximum transition time. 从 -40°C ~ +125°C 1000 次循环。在试验结束后 24 ± 2 小时测试。每个温度的停留时间不超过 30 分钟。转换时间不超过 1 分钟。	$\Delta F/F_0 \leq \pm 10\text{ppm}$ ESR ≤ 5Ω or 20%	JESD22 Method JA-104
8.3	Biased Humidity 稳态湿热	1000 hours 85°C/85%RH. Rated VDD applied with 1MΩ and inverter in parallel, 2X resonator CL capacitors between each resonator leg and GND. Measurement at 24±2 hours after test conclusion. 在温度 85°C，湿度 85% 的条件下放置 1000 个小时在试验结束后 24±2 小时测试。	$\Delta F/F_0 \leq \pm 10\text{ppm}$ ESR ≤ 5Ω or 20%	MIL-STD-202 Method 103
8.4	Operational Life 高温寿命	125°C 1000 hrs. Measurement at 24±2 hours after test conclusion. 125°C 下 1000 个小时，用相同测试线路在时间结束后 24±2 小时测试。	$\Delta F/F_0 \leq \pm 10\text{ppm}$ ESR ≤ 5Ω or 20%	MIL-STD-202 Method 108

8.5	Mechanical Shock 机械冲击	MIL-STD-202 Method 213 Figure 1 of Method 213. Condition C 见 213 方法, 试验条件: 半正弦波 峰值 100g 持续时间 6ms 速度变化 3.75m/s, 对样品 6 个方向 3 次, 共 18 次施以冲击	$\Delta F/F_0 \leq \pm 10\text{ppm}$ ESR $\leq 5\Omega$ or 20%	MIL-STD-202 Method 213
8.6	Vibration 振动	MIL-STD-202 Method 204 5g 的力 20 分钟, 用 8*5*0.031 英寸的 PCB 在 3 个方向各做 12 个循环。在 8 英寸边上有 7 个支撑点, 在对面角上两个支撑点。器件安装在任意一个支撑点的 2 英寸范围内。测试从 10HZ-2000HZ.	$\Delta F/F_0 \leq \pm 10\text{ppm}$ ESR $\leq 5\Omega$ or 20%	MIL-STD-202 Method 204
8.7	Resistance to Soldering Heat 耐焊接热	Condition B No pre-heat of samples. Note: Single Wave solder - Procedure 1 with solder within 1.5 mm of device body for Leaded. Procedure 1 except 245°C and immerse only to level to cover terminals for SMD. 未预热的样品 Condition B. 备注: 单波焊接 - Procedure 1 引脚产品焊料少于 1.5mm, 除了 245°C 外其他 Procedure 1, SMD 产品浸到覆盖 SMD 引脚。	$\Delta F/F_0 \leq \pm 10\text{ppm}$ ESR $\leq 5\Omega$ or 20%	MIL-STD-202 Method 210
8.8	Solderability 可焊性	引脚产品: Method A @ 245°C, category 3. SMD 产品: Method D category 3 @ 260°C ✓	Electrical Test not required. Magnification 50X. >95% tin 不测电参数 >95% 浸润.	J-STD-002
8.9	Board Flex 线路板弯曲	60 sec minimum holding time. 最少保留 60 秒。	10 倍放大镜下检查没有明显伤痕。	AEC Q200-005
8.10	Terminal Strength 引线、引脚强度 (SMD)	Terminal Strength Surface Mount / Shear Stress Test 施加 1.8kg 力 60 sec 测试带引脚器件的引脚整体试验。 条件: A(2.27Kg) C(227g)	有明显断裂、伤痕。	AEC Q200-006

**9. All products are RoHS compliant**

### 10. Reflow Profile

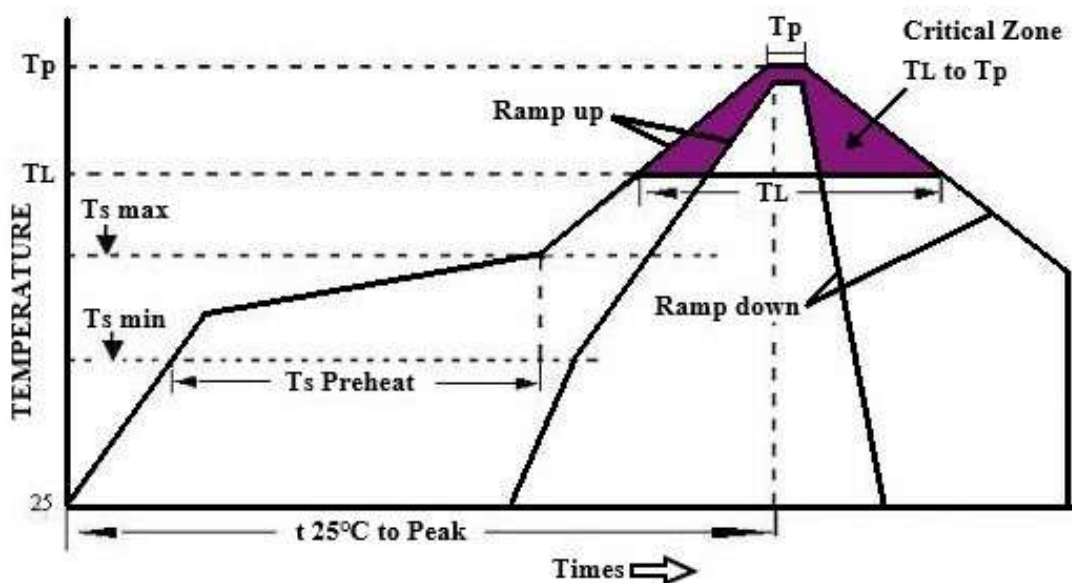

#### High Temperature Infrared /Convection

Note:Temperature shown are applied to body of device

Ts max to TL(Ramp-up Rate)	3°C/second max
Preheat	
Temperature Min(Ts Min)	150°C
Temperature Typical( Ts Typ)	175°C
Temperature Max.(Ts Max)	200°C
Time(ts)	60-180 seconds
Ram-up Rate(T <sub>L</sub> to T <sub>p</sub> )	3°C/second Max
Time Maintained Above:	
--Temperature(T <sub>L</sub> )	217°C
--Time(T <sub>L</sub> )	60-150seconds
Peak Temperature (T <sub>p</sub> )	260°C Max for 10 seconds
Time within 5°C of actual peak(t <sub>p</sub> )	20-40 seconds
Ramp-down Rate	6°C/seconds Max
Tune 25°C to Peak Temperature(t)	8 minutes Max
Moisture Sensitivity Level	Level 1

#### High Temperature Manual Soldering

Note:Temperature shown are applied to body of device

260°C Max for 10 seconds Max, 4 times Max