

REACH & RoHS  
COMPLIANT

REV.	ECN / DESCRIPTION	BY	DATE
A0	NEW	X.YAN	2017.10.30

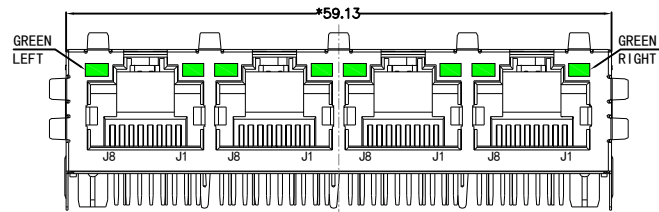

FRONT VIEW

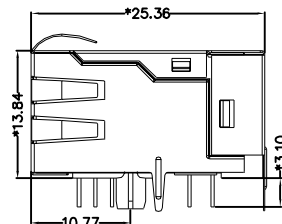

RIGHT SIDE VIEW

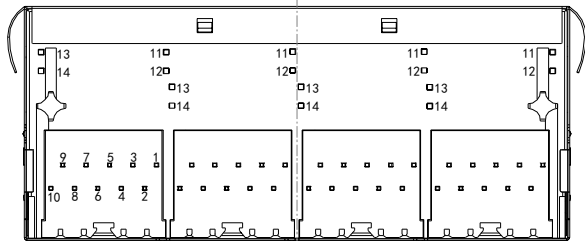

BOTTOM VIEW

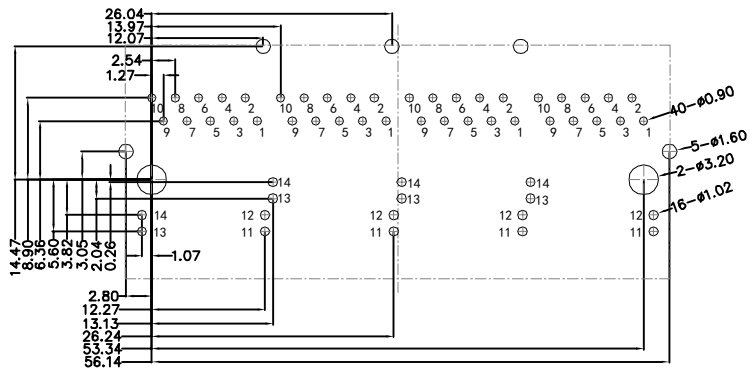

RECOMMENDED PCB LAYOUT  
VIEWED FROM COMPONENT SIDE

**MATERIAL:**

HOUSING: PA66,UL94V-0,BLACK.

TERMINALS BRACKET: PA66,UL94V-0,BLACK.

SHIELD: C2680,T=0.20MM,NICKEL PLATING ON ALL AREA.

TERMINAL: PHOSPHOR BRONZE C5191,T=0.35MM,  
6U" GOLD PLATING ON CONTACT AREA.

**MECHANICAL:**

DURABILITY: 750 CYCLES MIN.

MATING FORCE: 23N MAX.

OPERATING TEMPERATURE: -40°C~+85°C.

STORAGE TEMPERATURE: -40°C~+85°C.

ALL CRITICAL DIMENSIONS WITH "\*"

**CND-tek**  
磁联达

深圳磁联达电子有限公司  
Shenzhen magnetic Lianda Electronics Co., LTD

Address: 505, West Block, No. 221, Niucheng Road, Niucheng Village, Baiwang  
Community, Xili Street, Nanshan District, Shenzhen  
E-mail: sales1@cd-tek.com 0755-27652992 29016433 Website:www.cd-tek.com

TITLE:  
TAB-UP 1X4 1000BASE

PART NO.:  
T14116ML6G

REMARK:

SIZE  
A4

SACLE  
1:1

SHEET  
1/3

UNITS  
MM[INCH]

REV  
A0

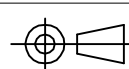

GENERAL TOLERANCES  
UNLESS SPECIFIED

x±0.35	x°±3.0°
.x±0.30	.x°±2.0°
.xx±0.25	.xx°±1.5°
.xxx±0.10	.xxx°±1.0°

APPROVED BY:  
QG.CHEN

CHECKED BY:  
SL.WANG

DESIGND BY:  
X.YAN

REACH & RoHS  
COMPLIANT

REV.	ECN / DESCRIPTION	BY	DATE
A0	NEW	X.YAN	2017.10.30

Suggested Panel Opening:

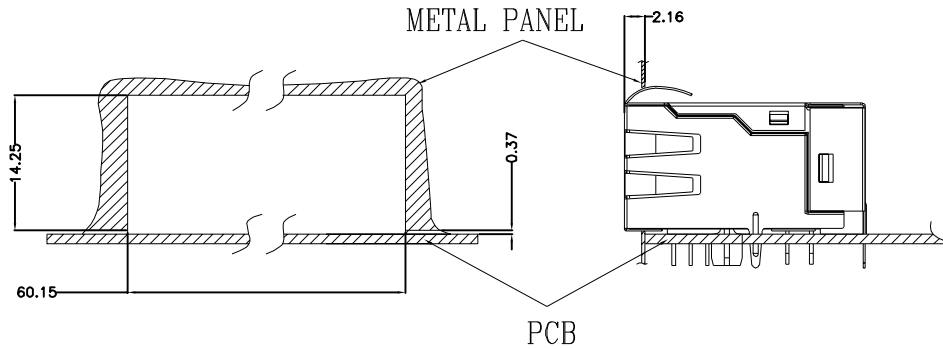

UNIT: mm / inch  
Tolerances:  $\pm 0.10$  / 0.004

Keep-Out Area (Component Side View):

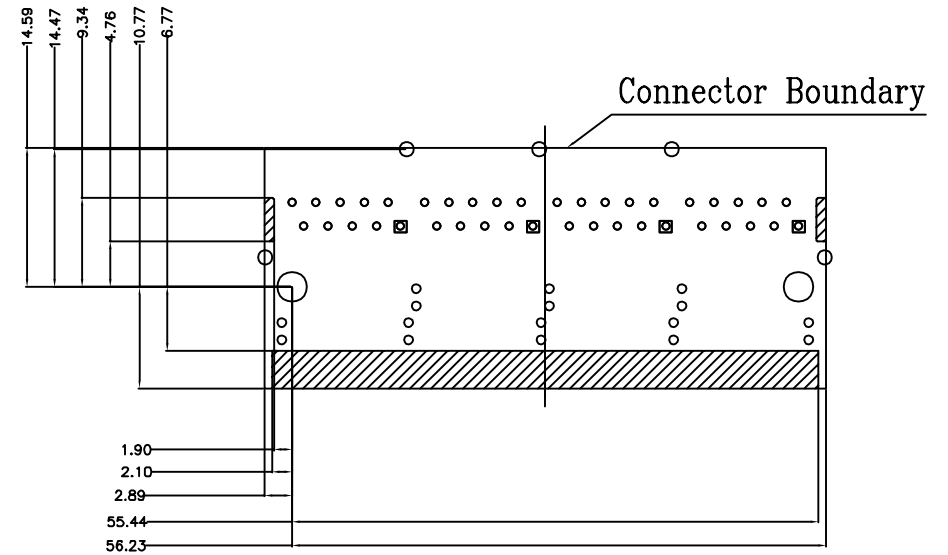

Plug-in side

UNIT: mm / inch  
Tolerances:  $\pm 0.10$  / 0.004

**CND-tek**  
磁联达

深圳磁联达电子有限公司  
Shenzhen magnetic Lianda Electronics Co., LTD

Address: 505, West Block, No. 221, Niucheng Road, Niucheng Village, Baiwang  
Community, Xili Street, Nanshan District, Shenzhen  
E-mail: sales1@cd-tek.com 0755-27652992 29016433 Website:www.cd-tek.com

TITLE:  
TAB-UP 1X4 1000BASE

PART NO.:  
T14116ML6G

REMARK:

SIZE  
A4

SACLE  
1:1

SHEET  
2/3

UNITS  
MM[INCH]

REV  
A0

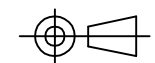

GENERAL TOLERANCES  
UNLESS SPECIFIED

$x \pm 0.35$	$x^\circ \pm 3.0^\circ$
$.x \pm 0.30$	$.x^\circ \pm 2.0^\circ$
$.xx \pm 0.25$	$.xx^\circ \pm 1.5^\circ$
$.xxx \pm 0.10$	$.xxx^\circ \pm 1.0^\circ$

APPROVED BY:  
QG.CHEN

CHECKED BY:  
SL.WANG

DESIGND BY:  
X.YAN

REACH & RoHS  
COMPLIANT

REV.	ECN / DESCRIPTION	BY	DATE
A0	NEW	X.YAN	2017.10.30

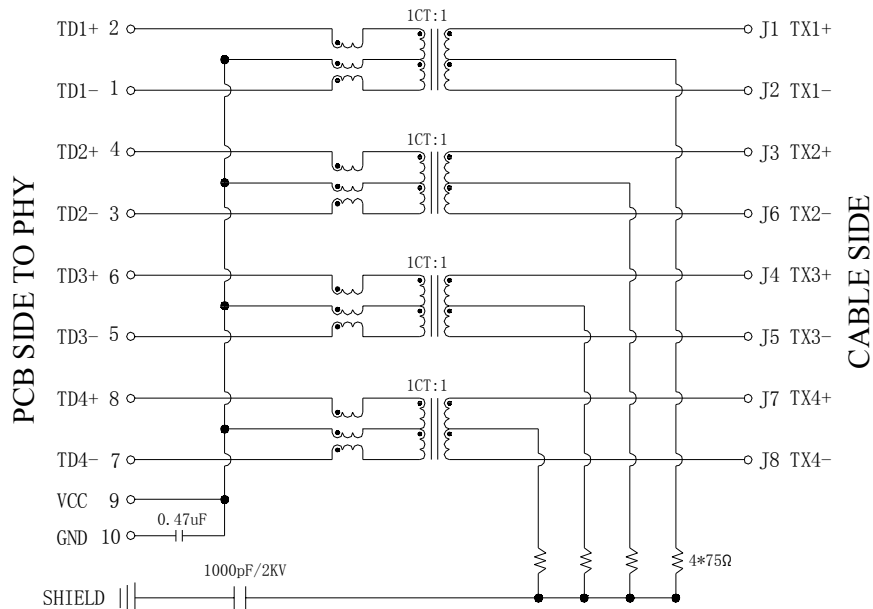

**Electrical:**

- Turn ratio: 2~1: J1~J2=1CT:1CT(±2%).  
4~3: J3~J6=1CT:1CT(±2%).  
6~5: J4~J5=1CT:1CT(±2%).  
8~7: J7~J8=1CT:1CT(±2%).
- OCL: 350uH Min. at 100KHz 100mV 8mA DC.
- Insertion Loss: -1.0 dB Max 1~100MHz.
- Return loss: -20dB Min 1~10MHz;  
-16dB Min 10~30MHz.  
-12dB Min 30~60MHz.  
-10dB Min 60~80MHz.
- Cross talk: -40dB Min 1~30MHz;  
-35dB Min 30~60MHz;  
-30dB Min 60~100MHz;
- CMR: -30dB Min 1~100MHz;
- Hi-Pot: 2250V DC 6S 1mA PRI TO SEC

**LED Specification**

Standard LED Color	LED Wavelength	Foward(A)	Foward(V)
Green	568nm	20mA	1.85-2.45V

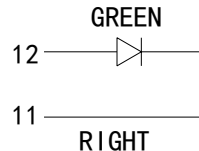
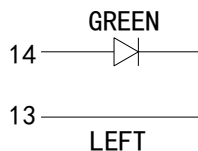

**CND-tek**  
磁联达

深圳磁联达电子有限公司  
Shenzhen magnetic Lianda Electronics Co., LTD

Address: 505, West Block, No. 221, Niucheng Road, Niucheng Village, Baiwang Community, Xili Street, Nanshan District, Shenzhen  
E-mail: sales1@cd-tek.com 0755-27652992 29016433 Website: www.cd-tek.com

TITLE:  
TAB-UP 1X4 1000BASE

PART NO.:  
T14116ML6G

REMARK:

SIZE  
A4

SACLE  
1:1

SHEET  
2/3

UNITS  
MM[INCH]

REV  
A0

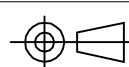

GENERAL TOLERANCES  
UNLESS SPECIFIED

x±0.35  
.x±0.30  
.xx±0.25  
.xxx±0.10

x°±3.0°  
.x°±2.0°  
.xx°±1.5°  
.xxx°±1.0°

APPROVED BY:  
QG.CHEN

CHECKED BY:  
SL.WANG

DESIGND BY:  
X.YAN

REACH & RoHS  
COMPLIANT

# PROFILE OF WAVE SOLDER

REV.	ECN / DESCRIPTION	BY	DATE
A0	NEW	X.YAN	2017.10.30

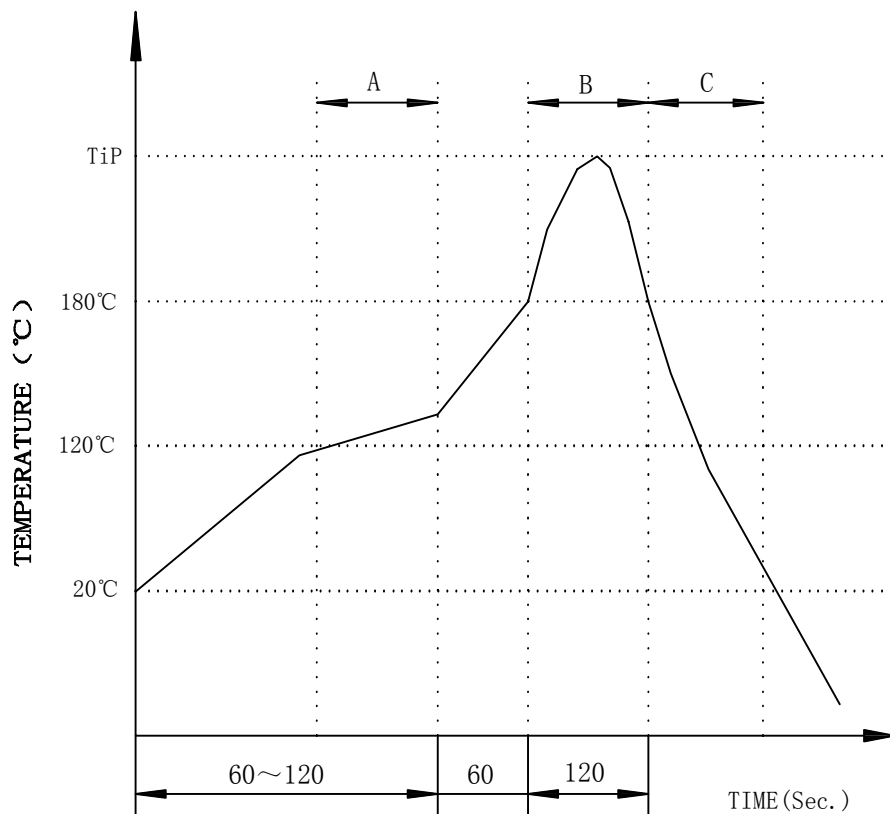

A.Preheating B.Soldering C.Gradual Cooling  
 Tip temperature:260±5°C.  
 Tip temperature time:5Sec Max.  
 Tip melting point of Sn96.5/Ag3/Cu0.5:217°C.

Remarks: after wave soldering, the plastic  
 positioning columns of the product which under the  
 PCB will be slightly melted, but it won't affect its  
 function.

**CND-tek**  
磁联达

深圳磁联达电子有限公司  
 Shenzhen magnetic Lianda Electronics Co., LTD  
 Address: 505, West Block, No. 221, Niucheng Road, Niucheng Village, Baiwang  
 Community, Xili Street, Nanshan District, Shenzhen  
 E-mail: sales1@cd-tek.com 0755-27652992 29016433 Website:www.cd-tek.com

TITLE: TAB-UP 1X4 1000BASE	SIZE A4	UNITS MM[INCH]	GENERAL TOLERANCES UNLESS SPECIFIED		APPROVED BY: QG.CHEN
PART NO.: T14116ML6G	SACLE 1:1	REV A0	x±0.35	x°±3.0°	CHECKED BY: SL.WANG
REMARK:	SHEET 3/3		.xx±0.25	.xx°±1.5°	
			.xxx±0.10	.xxx°±1.0°	DESIGND BY: X.YAN