

- NOTES:
1. ASSURE ASSEMBLY CAPABILITY BY MATCHING WITH MATING PART
  2. DIMENSIONS IN BRACKETS ARE IN MILLIMETERS

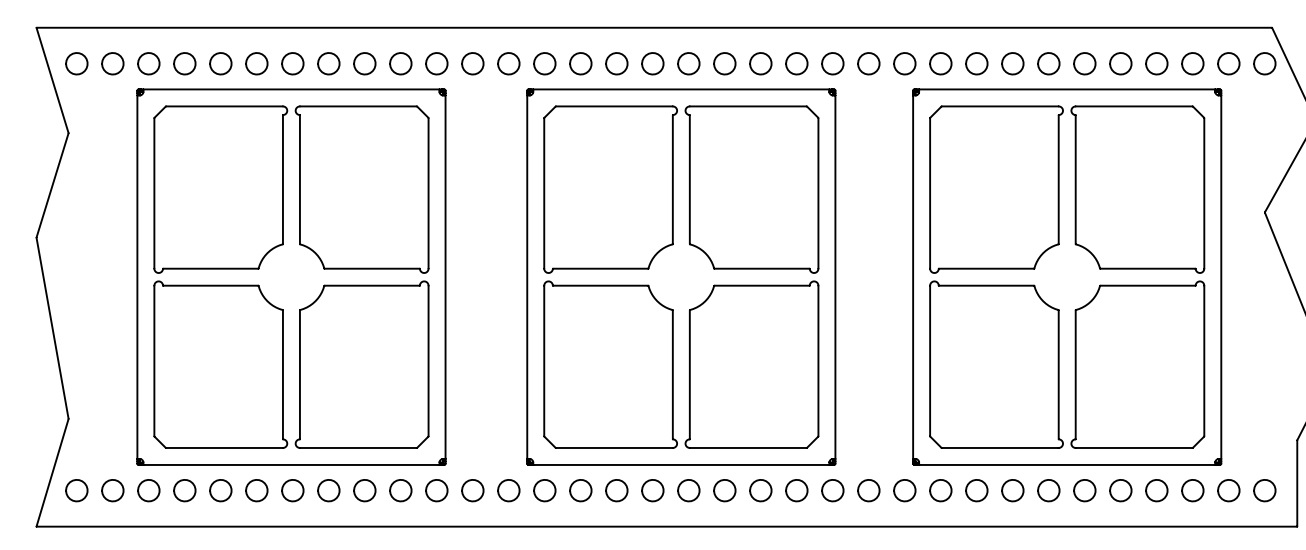
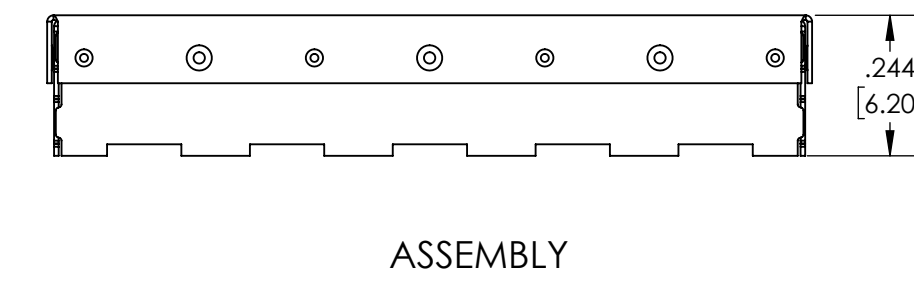
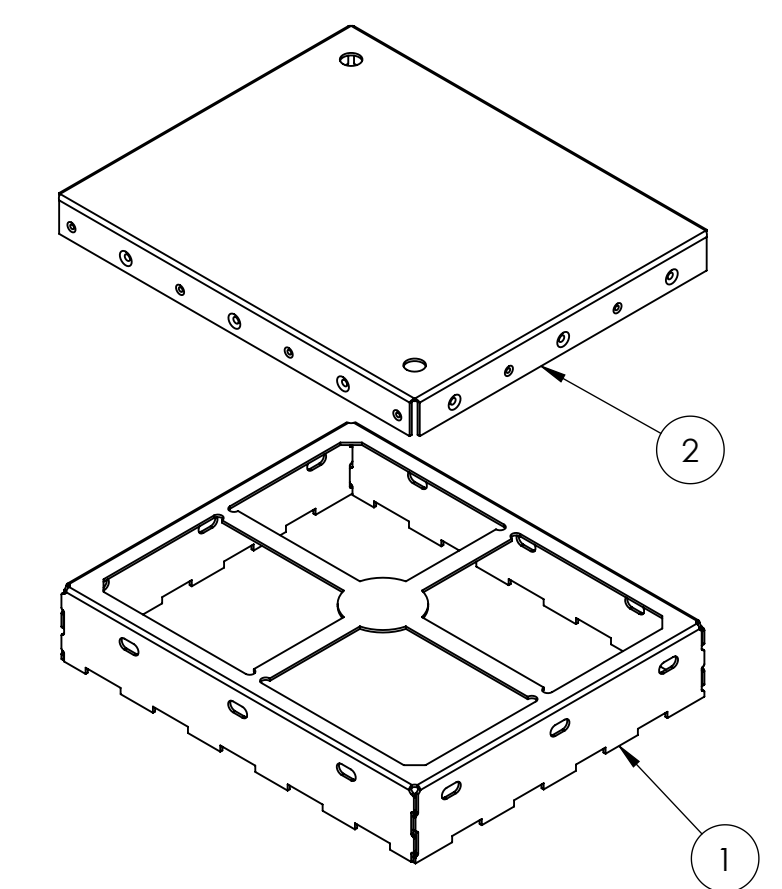
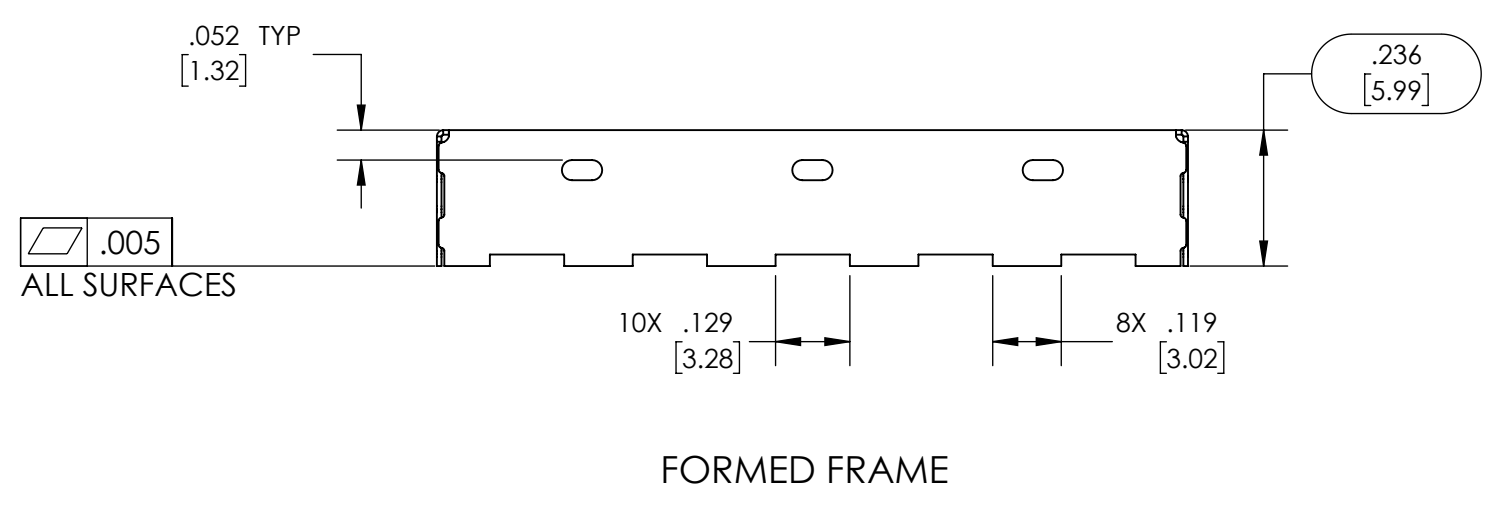
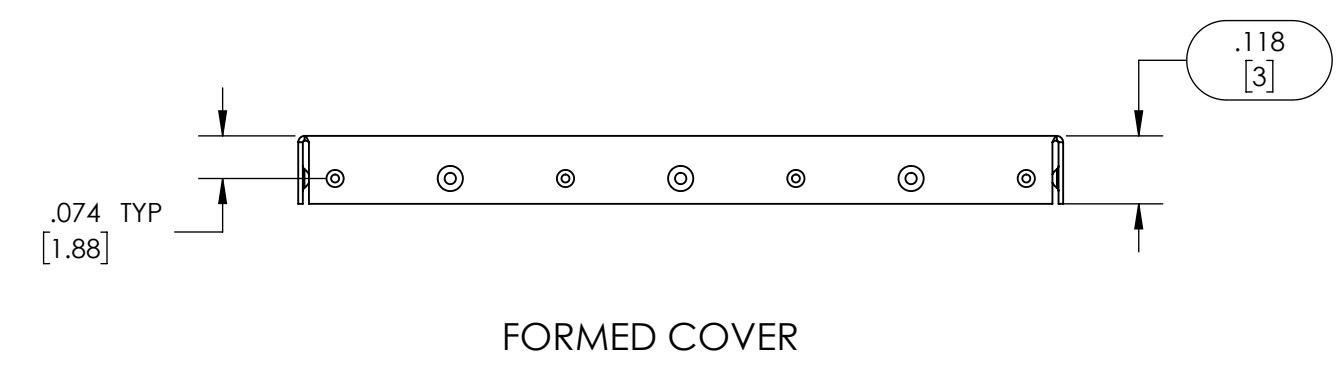
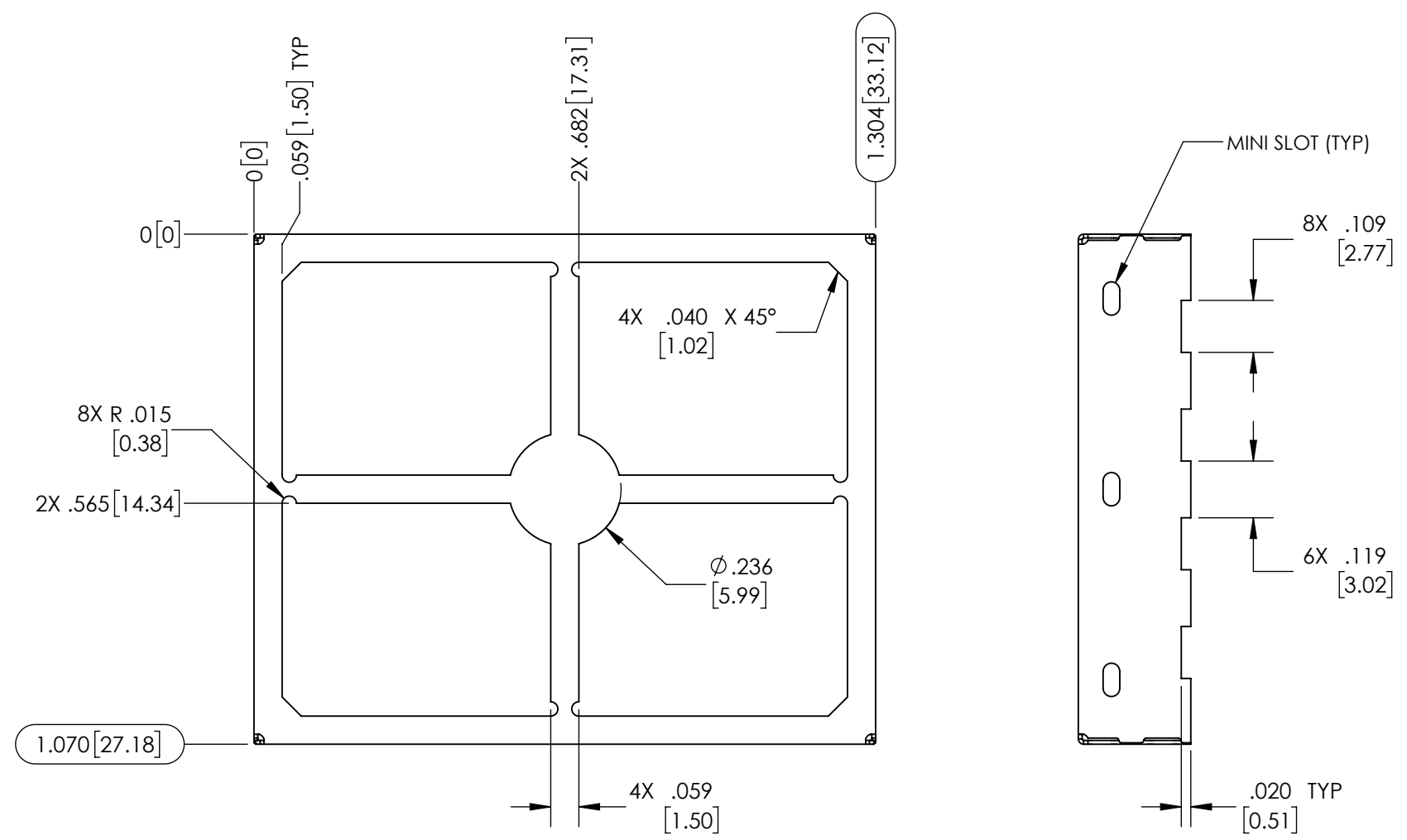
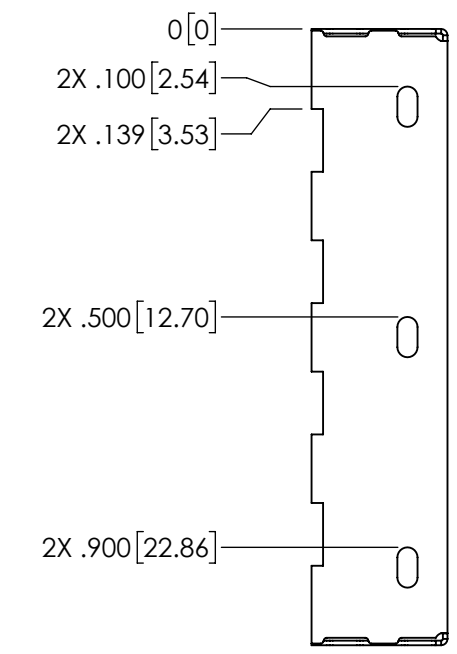
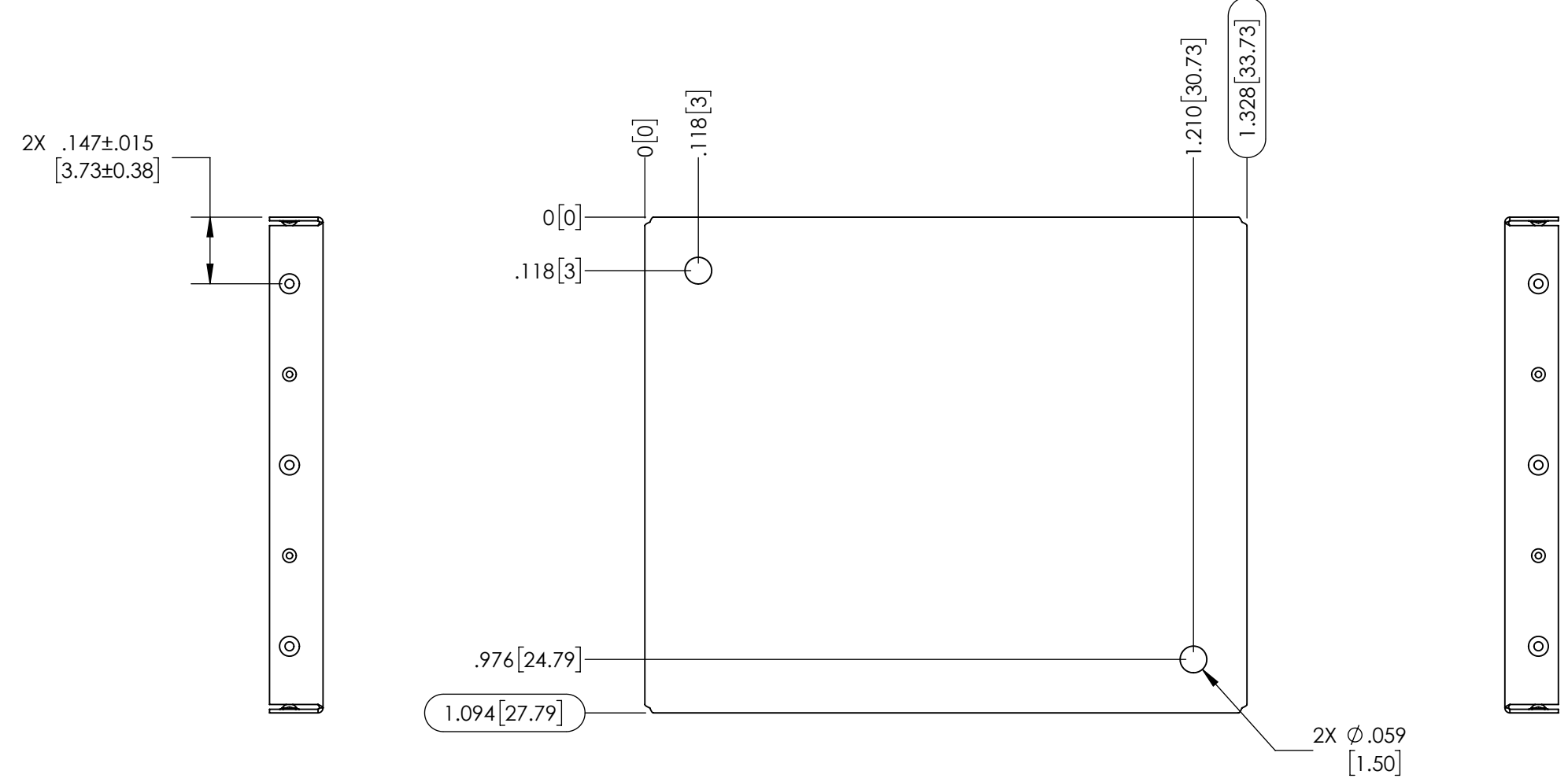
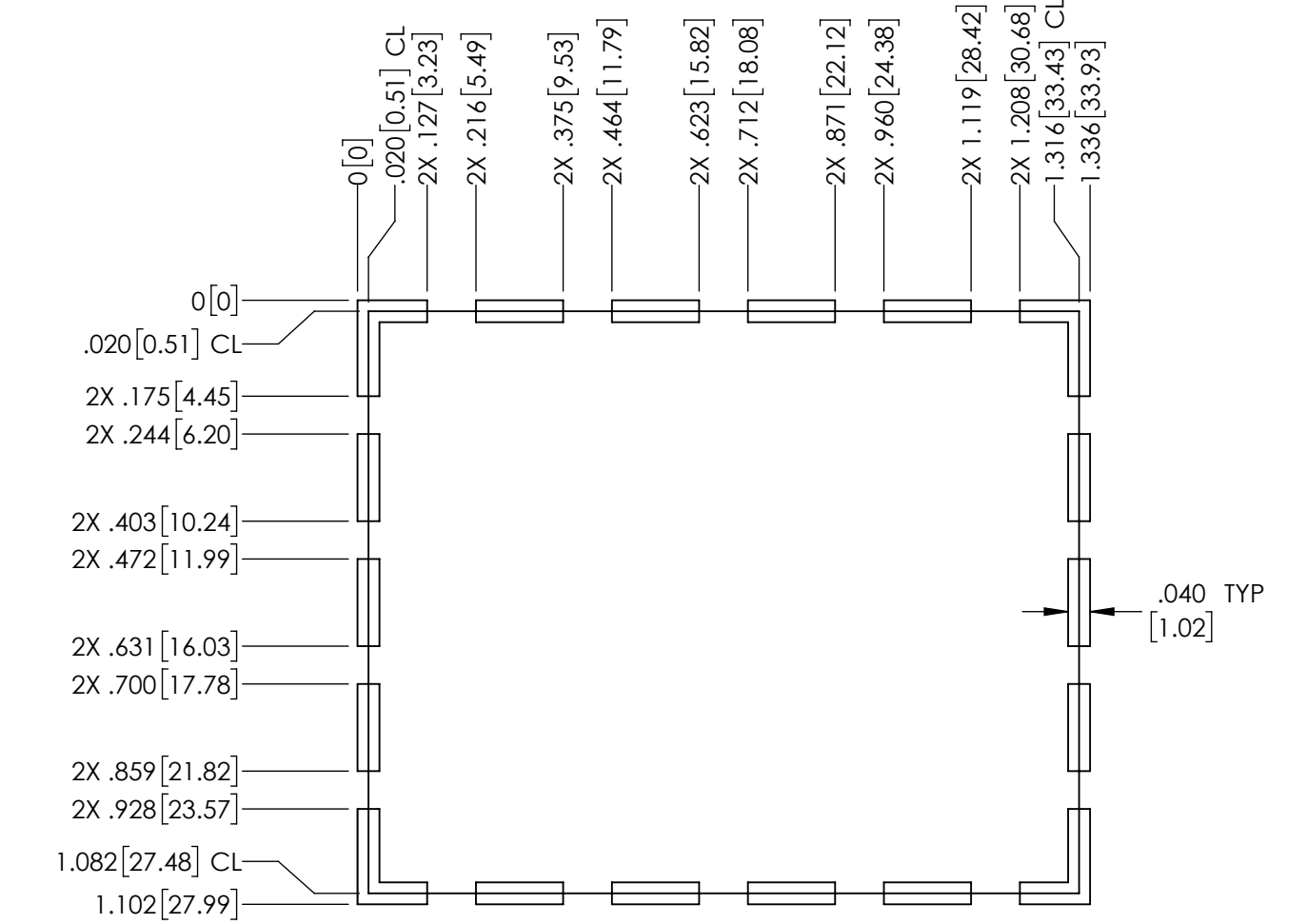
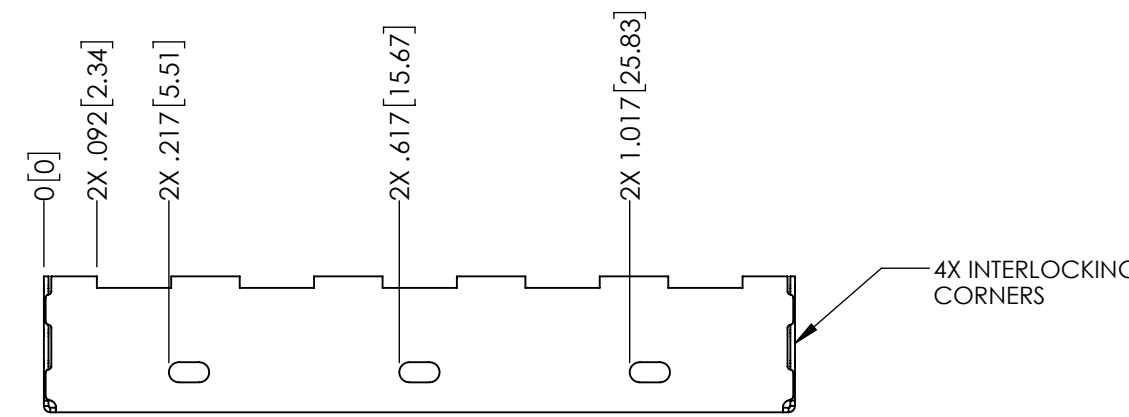
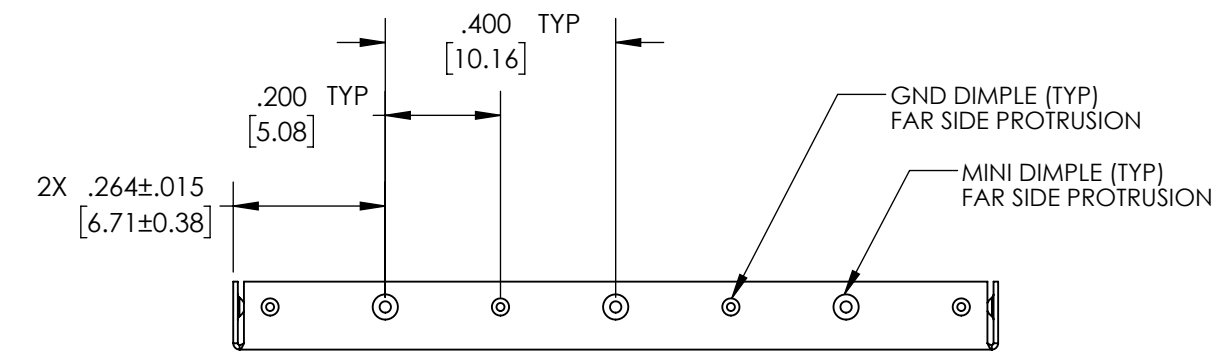

CARRIER TAPE SPECIFICATIONS						
PART NUMBER	DESCRIPTION	OVERALL DIMENSIONS	OVERALL HEIGHT	CARRIER TAPE WIDTH	CARRIER TAPE PITCH	PARTS PER REEL
SMS-457-N-F	FRAME	1.070 X 1.304 [27.18 X 33.12]	.236 [5.99]	44 mm	40 mm	210
SMS-457-N-C	COVER	1.094 X 1.328 [27.79 X 33.73]	.118 [3.00]	N/A	N/A	BULK PACK

THIS DOCUMENT CONTAINS PROPRIETARY INFORMATION OWNED BY LEADERTECH OR DEVELOPED AT ITS OWN PRIVATE EXPENSE AND MAY NOT BE USED, DUPLICATED OR DISCLOSED IN WHOLE OR IN PART FOR ANY PURPOSE INCLUDING DESIGN, MANUFACTURE OR PROCUREMENT WITHOUT THE WRITTEN PERMISSION OF LEADERTECH. LEADERTECH DOES NOT GUARANTEE OR WARRANT THE PERFORMANCE CHARACTERISTICS.

ITEM NO.	PART NUMBER	DESCRIPTION	QTY.
1	SMS-457-N-F	FRAME	1
2	SMS-457-N-C	COVER	1

UNLESS OTHERWISE SPECIFIED:  
 - ALL DIMENSIONS ARE IN INCHES  
 - PART SHALL BE FREE OF BURRS AND SHARP EDGES  
 - ALL DIMENSIONS SHOWN APPLY AFTER PLATING AND COATINGS  
 - ROHS COMPLIANT PER EU DIRECTIVE 2011/65/EU  
 - POI = POINT OF INTERSECTION

THIRD ANGLE PROJECTION  
 ANGLES +/- 2°

DRAWN BY: SDH  
 APPROVED BY: 2016-09-20

FRS: N/A  
 MATERIAL: .008[0.20] C77000 H02 (ALLOY 770) PER ASTM B122/B122M

SCALE: 3:1  
 CAGE CODE: 4J674  
 SHEET: 1 OF 1

DATE: D  
 DWG. NO.: SMS-457-N  
 REV: A

TITLE: SURFACE MOUNT SHIELD

LEADER TECH  
 a HEICO company  
 The Leading Edge in EMI Shielding Technology