

SAMZO REAC/ROHS

REV	ECN NO	DESCRIPTION	DESIGN	APPROVAL	DATE
A1	NEW	Replace frame			2018.06.12

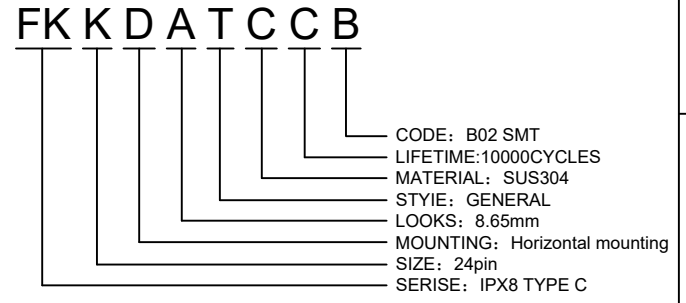

- NOIES:**
- ELECTRICAL CHARACTERISTICS:**
 - CONTACT CURRENT RATING: 5.0A FOR VBUS PIN AND ITS CORRESPONDING GND PIN.
 - CONTACT RESISTANCE: 30 MILLIOHMS MAX FOR VBUS AND GND CONTACTS. 40 MILLIOHMS MAX FOR ALL OTHER CONTACTS.
 - DIELECTRIC WITHSTANDING VOLTAGE: 100 VRMS AC MIN.
 - INSULATION RESISTANCE: 100 MEGOHMS MIN.
 - MECHANICAL CHARACTERISTICS:**
 - CONNECTOR INSERTION FORCE: 5~20N. AT A MAXIMUM RATE OF 12.5MM PER MINUTE.
 - CONNECTOR EXTRACTION FORCE: 8~20N AT A MAXIMUM RATE OF 12.5MM PER MINUTE. 6~20N AFTER DURABILITY TEST.
 - DURABILITY: 10000 CYCLES.
 - OPERATING TEMPERATURE: -55°C TO +85°C
 - SALT SPRAY: 48HOURS.
 - DIMENSIONS ARE IN MILLIMETERS, BRACKETED DIMENSIONS ARE INCHES EQUIVALENTS.
 - RECOMMENED PROCESS: IR REFLOW 260°C, 3~5SECONDS.
 - THE CONNECTOR IS ROHS COMPLIANT AND HALOGEN FREE COMPLIAN.
 - Mark " " REFERS TO FAI INSPECTION DIMENSION
 - Mark " " IS THE KEY INSPECTION DIMENSION OF IPQC
 - Mark " " IS CPK SIZE

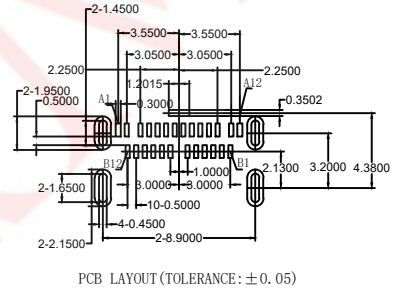
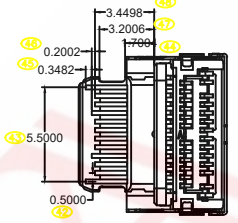
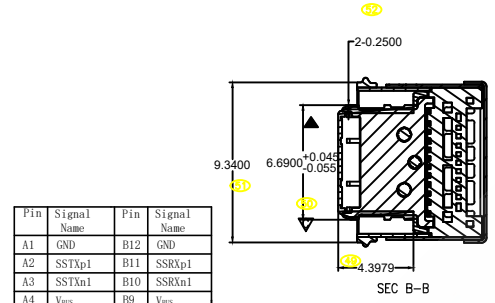
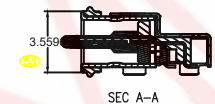
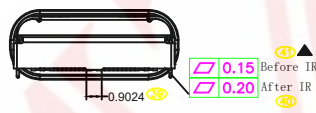
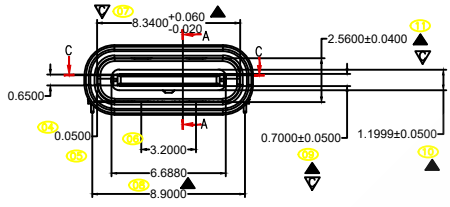
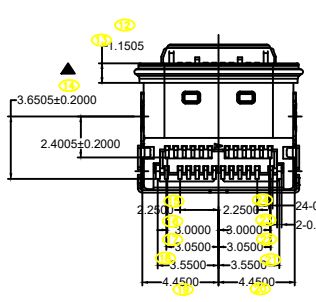
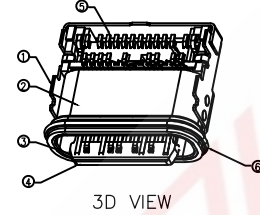
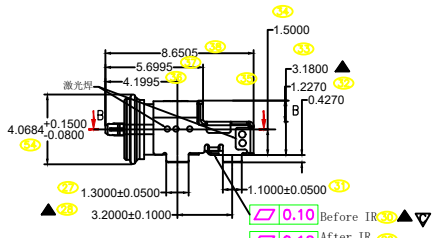
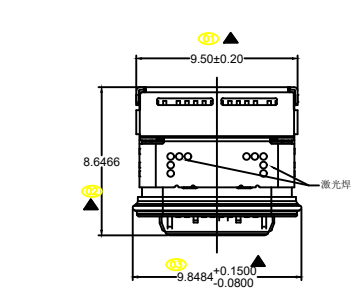

Pin	Signal Name	Pin	Signal Name
A1	GND	B12	GND
A2	SSTxp1	B11	SSRXp1
A3	SSTXn1	B10	SSRXn1
A4	Vbus	B9	Vbus
A5	CC1	B8	SBU2
A6	Dp1	B7	Dn2
A7	Dn1	B6	Dp2
A8	SBU1	B5	CC2
A9	Vbus	B4	Vbus
A10	SSRXn2	B3	SSTXn2
A11	SSRXp2	B2	SSTXp2
A12	GND	B1	GND

ITEM	PART NAME	QTY	Material&Plating
1	SUB-SHELL	1	SUS304 t=0.15, Ni PLATED 30u"
2	MAIN-SHELL	1	SUS316L t=0.20 CLEANING
3	LATCH	1	SUS301 t=0.15, Ni PLATED 30u"
4	HOUSING	1	PA9T+30%GF, HF BLACK
5	CONTACT	24	C7025 t=0.12, Ni 50-150u" UNDER PLATED OVER 30u"Au PLATED ON THE CONTACT AREA, 3-8u"Au PLATED ON THE SOLDER TAILS.
6	LIM	1	CHN-LIMS-60A/B; Pull force 300g SUS304 t=0.30 CLEANING

DESIGN	WANGGUIFA	2018.06.12	≥2~5<	±0.25
CHECKED	ZHENGUILAN	2018.06.12	≥0~2<	±0.15
APPROVED	LILIANJIANG	2018.06.14	≥5	±0.35

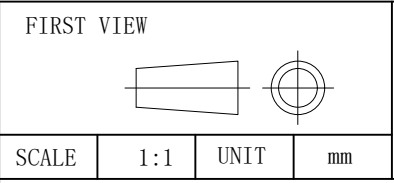

The copyright belongs to samzo parts (China) Co., Ltd. please use the material after samzo parts agree to authorize. The final right of interpretation belongs to samzo parts. WWW.KKK-JP.COM

SAMZO COMPONENTS
Electronic switch and connector manufacturer

TITLE: TYPE-C 24Pin 8.65MM 板上型 SMT IPX8
DWG NO: FKK24-P2924
PART NO: FKK2402924
MODEL NO: FKKDATCCB
NAME: TYPE-C CONN