

Thank you for your interest in **onsemi** products.  
Your technical document begins on the following pages.



## Your Feedback is Important to Us!

Please take a moment to participate in our short survey.  
At **onsemi**, we are dedicated to delivering technical content that best meets your needs.

### [Help Us Improve – Take the Survey](#)

This survey is intended to collect your feedback, capture any issues you may encounter, and to provide improvements you would like to suggest.

**We look forward to your feedback.**

To learn more about **onsemi**, please visit our website at  
[www.onsemi.com](http://www.onsemi.com)

**onsemi** and **onsemi** and other names, marks, and brands are registered and/or common law trademarks of Semiconductor Components Industries, LLC dba "**onsemi**" or its affiliates and/or subsidiaries in the United States and/or other countries. **onsemi** owns the rights to a number of patents, trademarks, copyrights, trade secrets, and other intellectual property. A listing of **onsemi** product/patent coverage may be accessed at [www.onsemi.com/site/pdf/Patent-Marking.pdf](http://www.onsemi.com/site/pdf/Patent-Marking.pdf). **onsemi** reserves the right to make changes at any time to any products or information herein, without notice. The information herein is provided "as-is" and **onsemi** makes no warranty, representation or guarantee regarding the accuracy of the information, product features, availability, functionality, or suitability of its products for any particular purpose, nor does **onsemi** assume any liability arising out of the application or use of any product or circuit, and specifically disclaims any and all liability, including without limitation special, consequential or incidental damages. Buyer is responsible for its products and applications using **onsemi** products, including compliance with all laws, regulations and safety requirements or standards, regardless of any support or applications information provided by **onsemi**. "Typical" parameters which may be provided in **onsemi** data sheets and/or specifications can and do vary in different applications and actual performance may vary over time. All operating parameters, including "Typicals" must be validated for each customer application by customer's technical experts. **onsemi** does not convey any license under any of its intellectual property rights nor the rights of others. **onsemi** products are not designed, intended, or authorized for use as a critical component in life support systems or any FDA Class 3 medical devices or medical devices with a same or similar classification in a foreign jurisdiction or any devices intended for implantation in the human body. Should Buyer purchase or use **onsemi** products for any such unintended or unauthorized application, Buyer shall indemnify and hold **onsemi** and its officers, employees, subsidiaries, affiliates, and distributors harmless against all claims, costs, damages, and expenses, and reasonable attorney fees arising out of, directly or indirectly, any claim of personal injury or death associated with such unintended or unauthorized use, even if such claim alleges that **onsemi** was negligent regarding the design or manufacture of the part. **onsemi** is an Equal Opportunity/Affirmative Action Employer. This literature is subject to all applicable copyright laws and is not for resale in any manner. Other names and brands may be claimed as the property of others.

# Intelligent Power Module (IPM), 600 V, 10 A

## STK544UC63K-E

The STK544UC63K-E is a fully-integrated inverter power stage consisting of a high-voltage driver, six IGBT's and a thermistor, suitable for driving permanent magnet synchronous (PMSM) motors, brushless-DC (BLDC) motors and AC asynchronous motors. The IGBT's are configured in a 3-phase bridge with separate emitter connections for the lower legs for maximum flexibility in the choice of control algorithm. The power stage has a full range of protection functions including cross-conduction protection, external shutdown and under-voltage lockout functions. An internal comparator and reference connected to the over-current protection circuit allows the designer to set the over-current protection level.

### Features

- Three-phase 10 A/600 V IGBT Module with Integrated Drivers
- Built-in Under Voltage Protection
- Cross-conduction Protection
- ITRIP Input to Shut Down All IGBTs
- Integrated Bootstrap Diodes and Resistors
- Thermistor for Substrate Temperature Measurement
- UL1557 Certification (File Number: E339285)
- These Devices are Pb-Free and are RoHS Compliant

### Typical Applications

- Industrial Drives
- Industrial Pumps
- Industrial Fans
- Industrial Automation

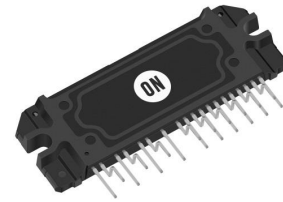

SIP23 62x21.8  
CASE 127FC

### MARKING DIAGRAM



STK544UC63K = Specific Device Code  
 ZZZ = Assembly Lot Code  
 A = Assembly Location  
 T = Test Location  
 Y = Year  
 WW = Work Week

Device marking is on package top side

### ORDERING INFORMATION

Device	Package	Shipping (Qty/Packing)
STK544UC63K-E	SIP23 62x21.8FP-4 (Pb-Free)	80/Box

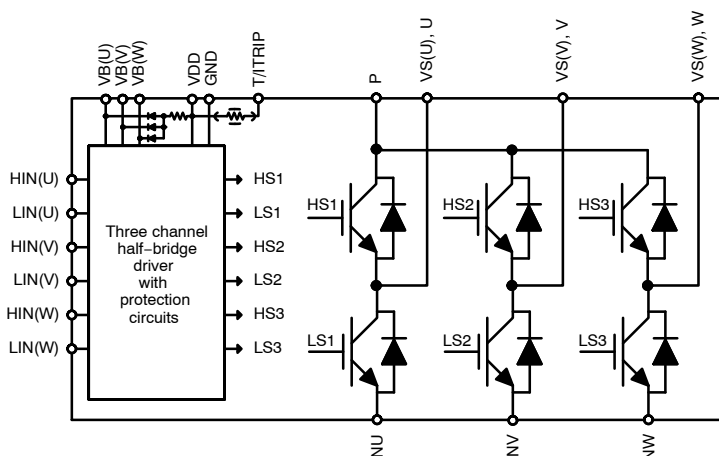

Figure 1. Functional Diagram

# STK544UC63K-E

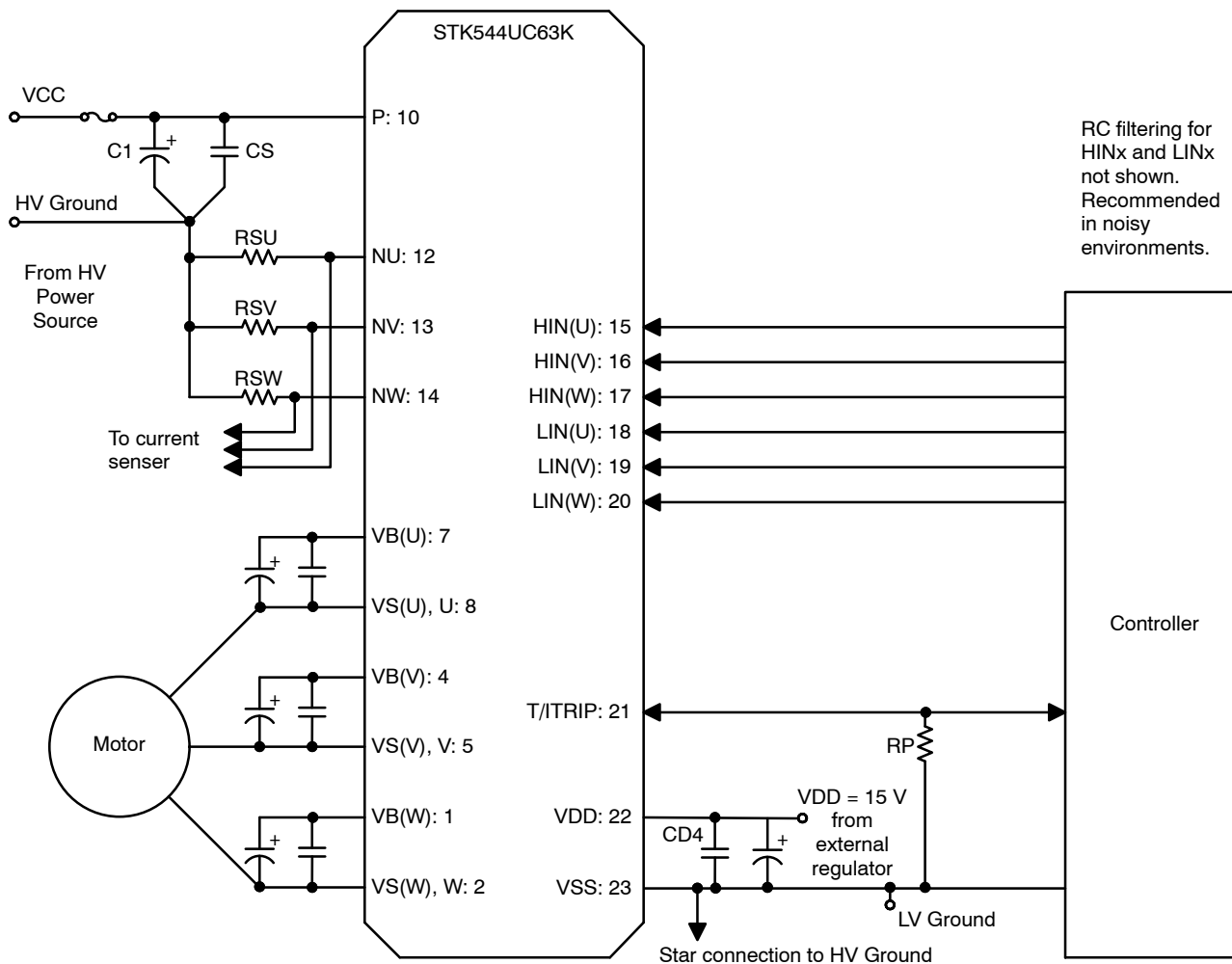

Figure 2. Application Schematic

# STK544UC63K-E

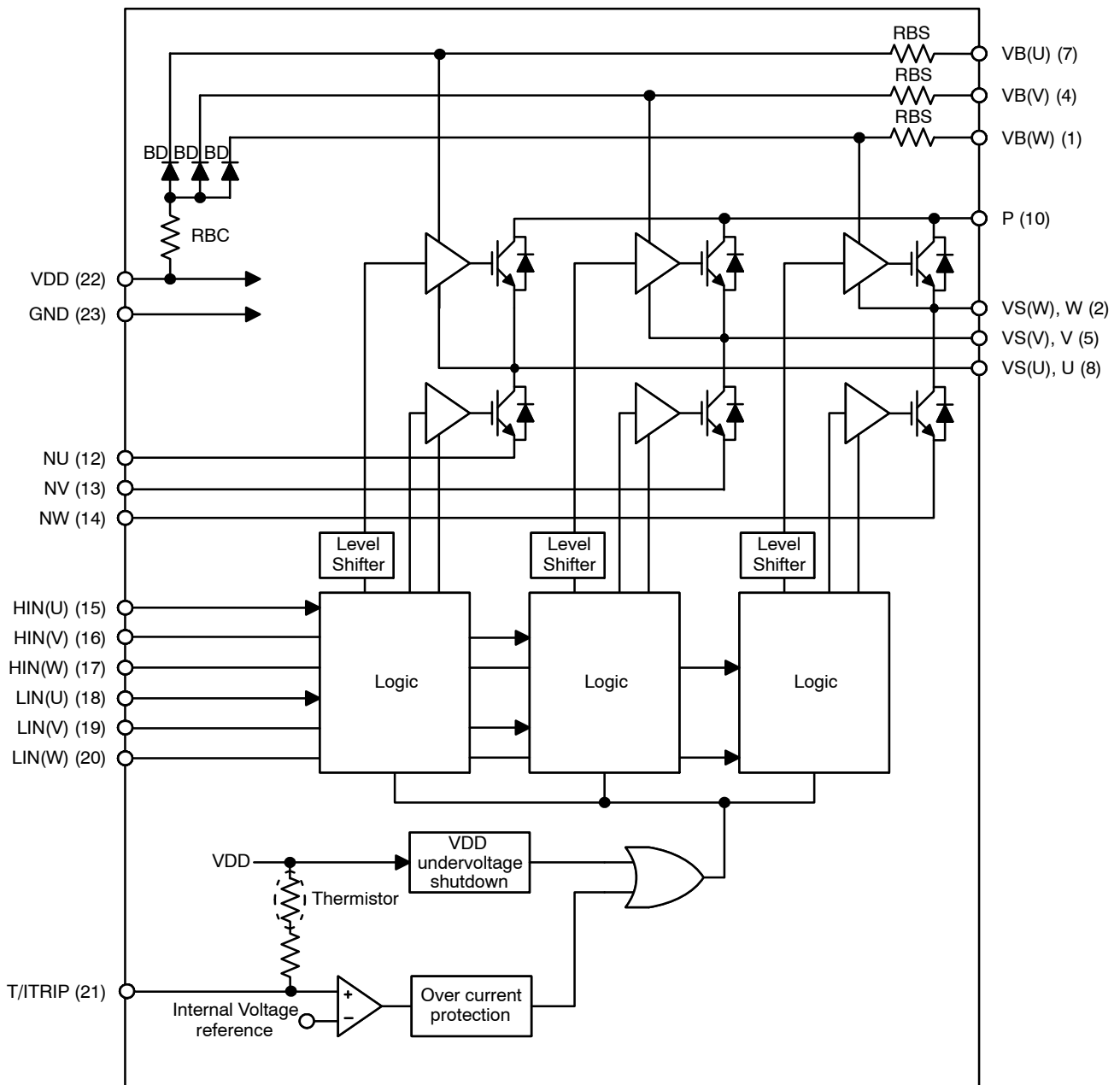

Figure 3. Simplified Block Diagram

# STK544UC63K-E

## PIN DESCRIPTION

Pin No.	Name	Description
1	VB(W)	High Side Floating Supply Voltage for W phase
2	VS(W), W	Internally connected to W phase high side driver ground. W phase output
4	VB(V)	High Side Floating Supply voltage for V phase
5	VS(V), V	Internally connected to V phase high side driver ground. V phase output
7	VB(U)	High Side Floating Supply voltage for U phase
8	VS(U), U	Internally connected to U phase high side driver ground. U phase output
10	P	Positive Bus Input Voltage
12	NU	Low Side Emitter Connection – Phase U
13	NV	Low Side Emitter Connection – Phase V
14	NW	Low Side Emitter Connection – Phase W
15	HIN(U)	Logic Input High Side Gate Driver – Phase U
16	HIN(V)	Logic Input High Side Gate Driver – Phase V
17	HIN(W)	Logic Input High Side Gate Driver – Phase W
18	LIN(U)	Logic Input Low Side Gate Driver – Phase U
19	LIN(V)	Logic Input Low Side Gate Driver – Phase V
20	LIN(W)	Logic Input Low Side Gate Driver – Phase W
21	T/ITRIP	Temperature Monitor and Shut-down pin
22	VDD	+15 V Main Supply
23	VSS	Negative Main Supply

1. Pins 3, 6, 9 and 11 are not present

## ABSOLUTE MAXIMUM RATINGS (at Tc = 25°C) (Note 2)

Symbol	Rating	Conditions	Value	Unit
V <sub>CC</sub>	Supply voltage	P to NU, NV, NW, surge < 500 V (Note 3)	450	V
V <sub>CE</sub>	Collector-emitter voltage	P to U, V, W; U to NU; V to NV; W to NW	600	V
I <sub>o</sub>	Output current	P, U, V, W, NU, NV, NW terminal current	±10	A
		P, U, V, W, NU, NV, NW terminal current, Tc = 100°C	±5	A
I <sub>op</sub>	Output peak current	P, U, V, W, NU, NV, NW terminal current, pulse width 1 ms	±20	A
P <sub>d</sub>	Maximum power dissipation	IGBT per 1 channel	20	W
V <sub>BS</sub>	Gate driver supply voltage	VB(U) to VS(U), VB(V) to VS(V), VB(W) to VS(W), VDD to VSS (Note 4)	-0.3 to +20.0	V
V <sub>IN</sub>	Input signal voltage	HIN(U), HIN(V), HIN(W), LIN(U), LIN(V), LIN(W)	-0.3 to +7.0	V
V <sub>ITRIP</sub>	ITRIP terminal voltage	T/ITRIP terminal	VSS to +5.0	V
T <sub>j</sub>	Junction temperature	IGBT, FRD	150	°C
T <sub>stg</sub>	Storage temperature		-40 to +125	°C
T <sub>c</sub>	Operating case temperature	IPM case temperature	-40 to +100	°C
MT	Tightening torque	Case mounting screws	0.9	Nm
V <sub>is</sub>	Isolation voltage	50 Hz sine wave AC 1 minute (Note 5)	2000	V <sub>rms</sub>

Stresses exceeding those listed in the Maximum Ratings table may damage the device. If any of these limits are exceeded, device functionality should not be assumed, damage may occur and reliability may be affected.

2. Refer to ELECTRICAL CHARACTERISTICS, RECOMMENDED OPERATING RANGES and/or APPLICATION INFORMATION for Safe Operating parameters.

3. This surge voltage developed by the switching operation due to the wiring inductance between P and NU, NV, NW terminal.

4. V<sub>BS</sub> = VB(U) to VS(U), VB(V) to VS(V), VB(W) to VS(W).

5. Test conditions: AC2500V, 1 s.

# STK544UC63K-E

## RECOMMENDED OPERATING CONDITIONS

Symbol	Rating	Conditions	Min	Typ	Max	Unit
V <sub>CC</sub>	Supply voltage	P to NU, NV, NW	0	280	450	V
V <sub>BS</sub>	Gate driver supply voltage	VB(U) to VS(U), VB(V) to VS(V), VB(W) to VS(W)	13.0	15	17.5	V
V <sub>DD</sub>		VDD to VSS	14.0	15	16.5	V
V <sub>IN(ON)</sub>	ON-state input voltage	HIN(U), HIN(V), HIN(W), LIN(U), LIN(V), LIN(W)	0	-	0.3	V
V <sub>IN(OFF)</sub>	OFF-state input voltage		3.0	-	5.0	V
f <sub>PWM</sub>	PWM frequency		1	-	20	kHz
DT	Dead time	Turn-off to Turn-on (external)	0.5	-	-	μs
PWIN	Allowable input pulse width	ON and OFF	1	-	-	μs
	Tightening torque	'M3' type screw	0.6	-	0.9	Nm

Functional operation above the stresses listed in the Recommended Operating Ranges is not implied. Extended exposure to stresses beyond the Recommended Operating Ranges limits may affect device reliability.

## ELECTRICAL CHARACTERISTICS (T<sub>C</sub> = 25°C, V<sub>BIAS</sub> (V<sub>BS</sub>, V<sub>DD</sub>) = 15 V unless otherwise noted)

Symbol	Parameter	Test Condition	Min	Typ	Max	Unit
--------	-----------	----------------	-----	-----	-----	------

### POWER OUTPUT SECTION

I <sub>CE</sub>	Collector-emitter leakage current	V <sub>CE</sub> = 600 V	-	-	0.1	mA
I <sub>R(BD)</sub>	Bootstrap diode reverse current	V <sub>R(DB)</sub> = 600 V	-	-	0.1	mA
V <sub>CE(SAT)</sub>	Collector to emitter saturation voltage	I <sub>C</sub> = 10 A, T <sub>j</sub> = 25°C	-	2.1	2.7	V
		I <sub>C</sub> = 5 A, T <sub>j</sub> = 100°C	-	1.7	-	V
V <sub>F</sub>	Diode forward voltage	I <sub>F</sub> = 10 A, T <sub>j</sub> = 25°C	-	2.2	2.8	V
		I <sub>F</sub> = 5 A, T <sub>j</sub> = 100°C	-	1.7	-	V
V <sub>F(BD)</sub>	Bootstrap diode forward voltage	I <sub>F</sub> = 0.1 A	-	2.0	-	V
R <sub>BC</sub>	Bootstrap circuit resistance	Resistor value for common boot charge line	-	2	-	Ω
R <sub>BS</sub>		Resistor value for separate boot charge line	-	10	-	Ω
θ <sub>j-c(T)</sub>	Junction to case thermal resistance	IGBT	-	4.9	6.2	°C/W
θ <sub>j-c(D)</sub>		FRD	-	8.5	10.6	°C/W

### DRIVER SECTION

ID	Gate driver consumption current	V <sub>BS</sub> = 15 V (Note 6), per driver	-	0.08	0.4	mA
ID		V <sub>DD</sub> = 15 V, total	-	2.0	4.0	mA
V <sub>IN H</sub>	High level Input voltage	HIN(U), HIN(V), HIN(W), LIN(U), LIN(V), LIN(W) to VSS	2.5	-	-	V
V <sub>IN L</sub>	Low level Input voltage		-	-	0.8	V
I <sub>IN+</sub>	Logic 0 input leakage current		76	118	160	μA
I <sub>IN-</sub>	Logic 1 input leakage current		97	150	203	μA
V <sub>ITRIP</sub>	ITRIP threshold voltage	T/ITRIP to VSS	3.67	4.17	4.67	V
t <sub>TRIP</sub>	ITRIP to shutdown propagation delay		0.8	1.1	1.4	μs
t <sub>TRIPBL</sub>	ITRIP blanking time		-	0.9	-	μs
FLTCLR	FAULT clearance delay time	Automatic reset after protection	6	9	12	ms
DT	Dead time (Internal dead time injected by driver)		220	300	380	μs
V <sub>CCUV+</sub> V <sub>BSUV+</sub>	V <sub>DD</sub> and V <sub>BS</sub> supply undervoltage positive going input threshold		10.5	11.1	11.7	V

# STK544UC63K-E

## ELECTRICAL CHARACTERISTICS (T<sub>c</sub> = 25°C, V<sub>BIAS</sub> (V<sub>BS</sub>, V<sub>DD</sub>) = 15 V unless otherwise noted)

Symbol	Parameter	Test Condition	Min	Typ	Max	Unit
V <sub>CCUV-</sub> V <sub>BSUV-</sub>	V <sub>DD</sub> and V <sub>BS</sub> supply undervoltage negative going input threshold		10.3	10.9	11.5	V
V <sub>CCUVH</sub> V <sub>BSUVH</sub>	V <sub>DD</sub> and V <sub>BS</sub> supply undervoltage lockout hysteresis		0.14	0.2	-	V

## SWITCHING CHARACTER

t <sub>ON</sub>	Switching time	IC = 10 A, T <sub>j</sub> = 25°C	-	0.35	0.7	μs
t <sub>OFF</sub>			-	0.45	0.8	μs
E <sub>ON</sub>	Turn-on switching loss	IC = 5 A, T <sub>j</sub> = 25°C	-	89	-	μJ
E <sub>OFF</sub>	Turn-off switching loss		-	74	-	μJ
E <sub>TOT</sub>	Total switching loss		-	163	-	μJ
E <sub>ON</sub>	Turn-on switching loss	IC = 5 A, T <sub>j</sub> = 100°C	-	125	-	μJ
E <sub>OFF</sub>	Turn-off switching loss		-	82	-	μJ
E <sub>TOT</sub>	Total switching loss		-	207	-	μJ
E <sub>REC</sub>	Diode reverse recovery energy	IC = 5 A, T <sub>j</sub> = 100°C	-	40	-	μJ
t <sub>RR</sub>	Diode reverse recovery time		-	150	-	ns
RBSOA	Reverse bias safe operating area	IC = 20 A, V <sub>CE</sub> = 450 V	Full Square			
SCSOA	Short circuit safe operating area	V <sub>CE</sub> = 400 V, T <sub>j</sub> = 150°C	5	-	-	μs

Product parametric performance is indicated in the Electrical Characteristics for the listed test conditions, unless otherwise noted. Product performance may not be indicated by the Electrical Characteristics if operated under different conditions.

6. V<sub>BS</sub> = V<sub>BU</sub> to U, V<sub>BV</sub> to V, V<sub>BW</sub> to W

TYPICAL CHARACTERISTICS INV SECTION

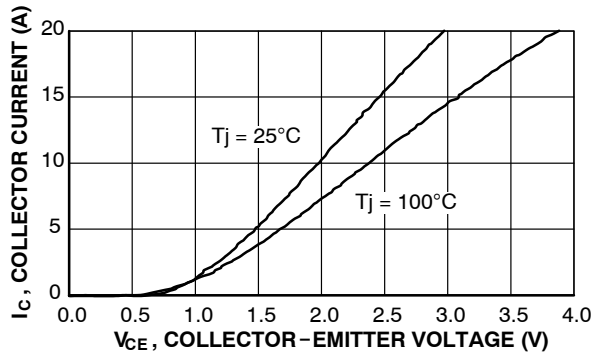

Figure 4.  $V_{CE}$  versus  $I_C$  for Different Temperatures ( $V_{DD} = 15\text{ V}$ )

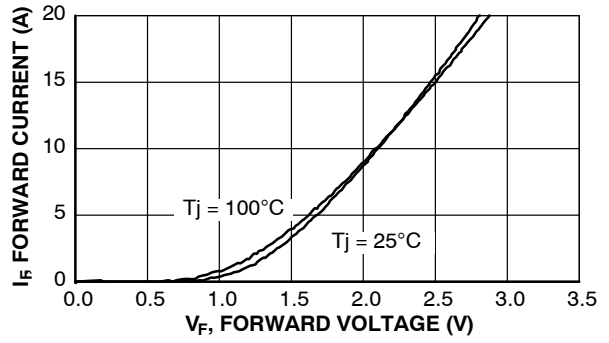

Figure 5.  $V_F$  versus  $I_F$  for Different Temperatures

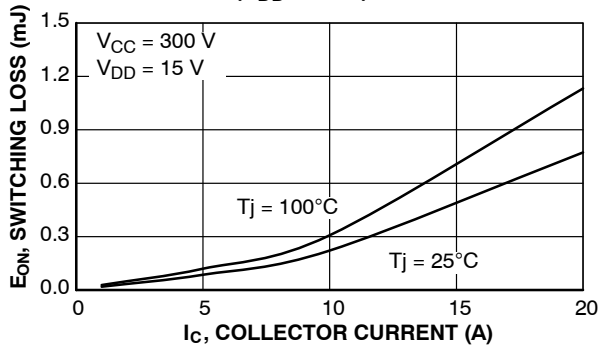

Figure 6.  $E_{ON}$  versus  $I_C$  for Different Temperatures

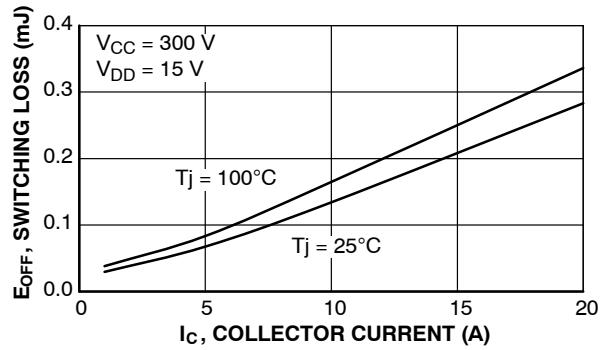

Figure 7.  $E_{OFF}$  versus  $I_C$  for Different Temperatures

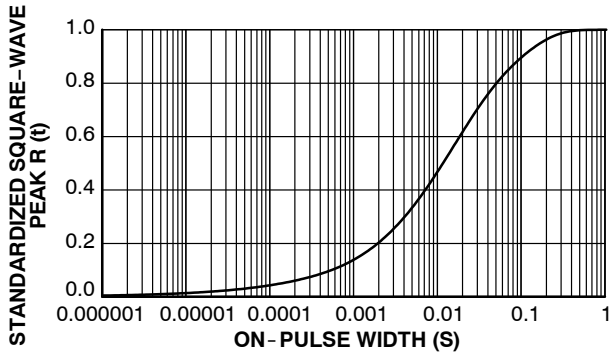

Figure 8. Thermal Impedance Plot

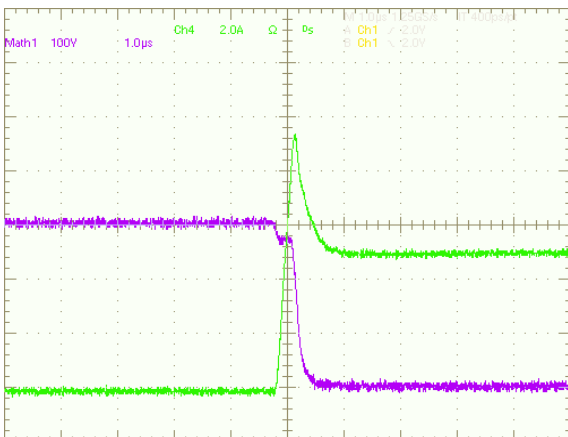

Figure 9. Turn-on Waveform  $T_j = 100^\circ\text{C}$ ,  $V_{CC} = 300\text{ V}$

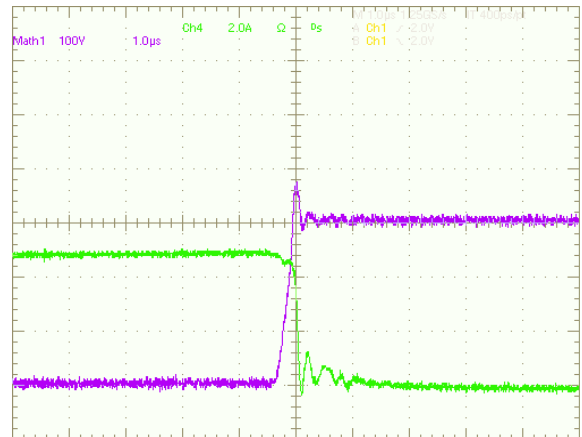

Figure 10. Turn-off Waveform  $T_j = 100^\circ\text{C}$ ,  $V_{CC} = 300\text{ V}$



APPLICATIONS INFORMATION

Input/Output Timing Chart

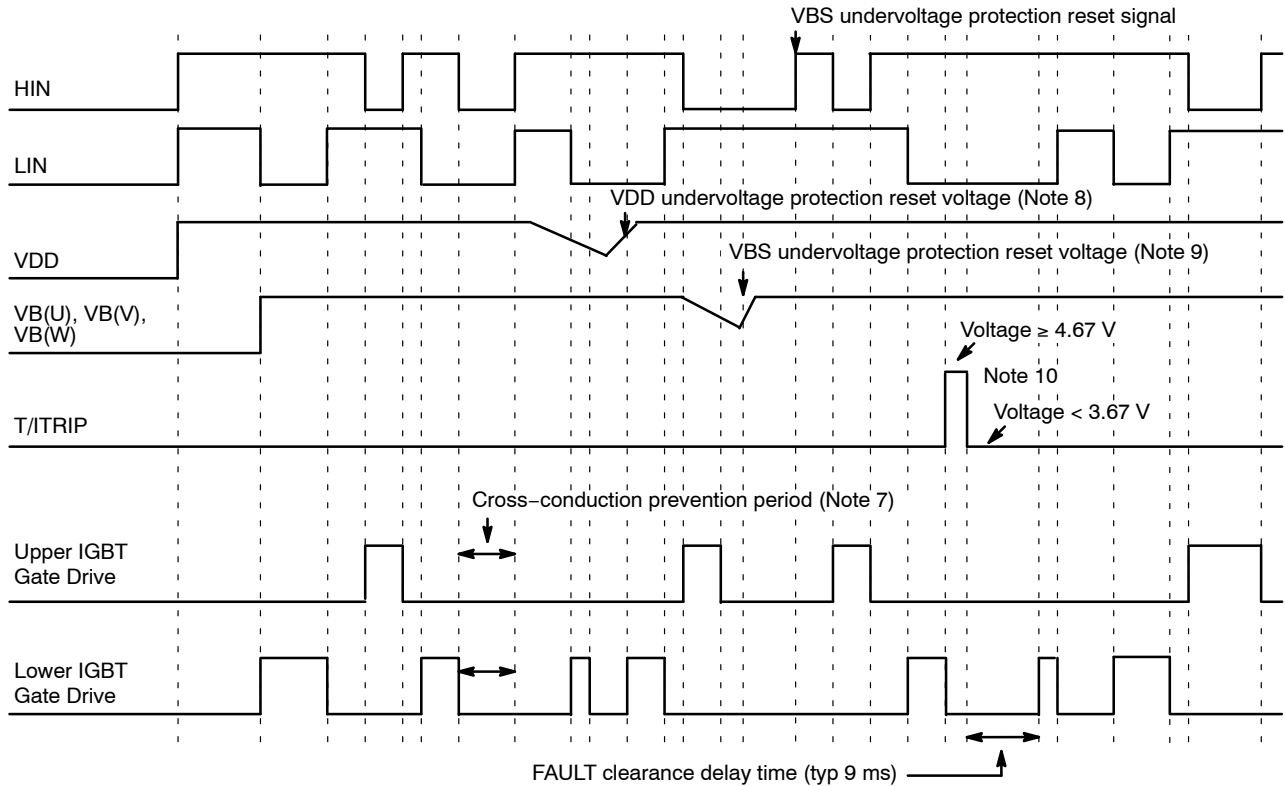

Figure 11. Input/Output Timing Chart

NOTES:

7. This section of the timing diagram shows the effect of cross-conduction prevention.
8. This section of the timing diagram shows that when the voltage on  $V_{DD}$  decreases sufficiently all gate output signals will go low, switching off all six IGBTs. When the voltage on  $V_{DD}$  rises sufficiently, normal operation will resume.
9. This section shows that when the bootstrap voltage on  $VB(U)$  ( $VB(V)$ ,  $VB(W)$ ) drops, the corresponding high side output U (V, W) is switched off. When the voltage on  $VB(U)$  ( $VB(V)$ ,  $VB(W)$ ) rises sufficiently, normal operation will resume.
10. This section shows that when the voltage on ITRIP exceeds the threshold, all IGBT's are turned off. Normal operation resumes later after the over-current condition is removed.

Input/Output Logic Table

Table 1. INPUT/OUTPUT LOGIC TABLE

INPUT			OUTPUT		
HIN	LIN	T/ITRIP	High Side IGBT	Low Side IGBT	U, V, W
L	H	L	ON	OFF	P
H	L	L	OFF	ON	NU, NV, NW
H	H	L	OFF	OFF	High Impedance
L	L	L	OFF	OFF	High Impedance
X	X	H	OFF	OFF	High Impedance

# STK544UC63K-E

## Thermistor Characteristics

Table 2. THERMISTOR CHARACTERISTICS

Symbol	Parameter	Condition	Min	Typ	Max	Unit
R <sub>25</sub>	Resistance	T <sub>th</sub> = 25°C	99	100	101	kΩ
R <sub>125</sub>		T <sub>th</sub> = 125°C	2.40	2.52	2.65	kΩ
B	B-Constant (25 to 50°C)		-4207	4250	4293	K
	Temperature Range		-40	-	+125	°C

# STK544UC63K-E

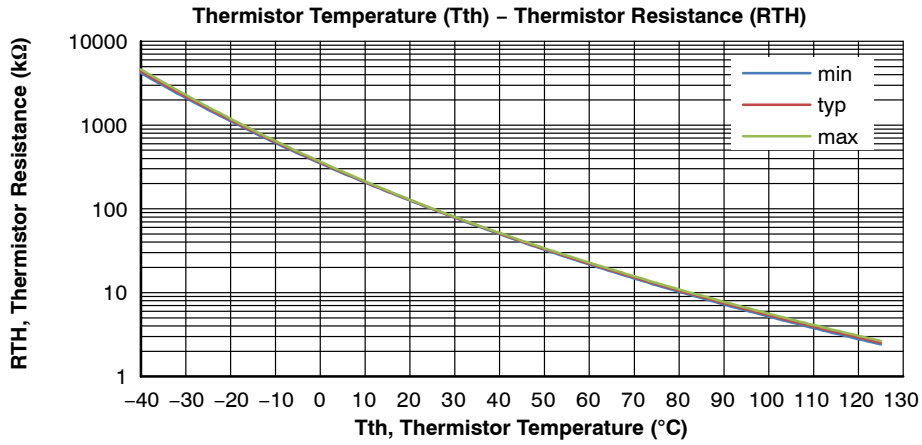

Figure 12. Thermistor Resistance versus Thermistor Temperature

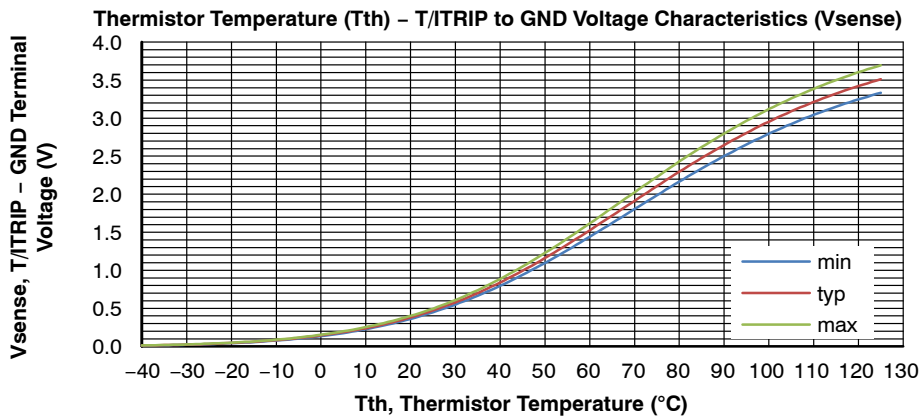

Figure 13. Thermistor Voltage versus Thermistor Temperature  
Conditions:  $R_P = 4.3 \text{ k}\Omega$  1% Pull-down and  $V_{DD} = 15.0 \text{ V}$  (See below)

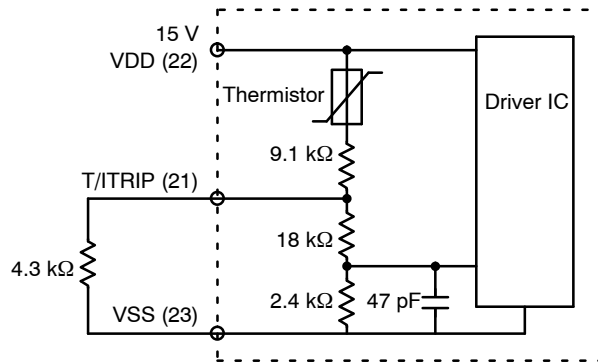

Figure 14. Sample Application Circuit for Temperature Monitoring

## TEST CIRCUITS

- $I_{CE, IR(DB)}$

	U+	V+	W+	U-	V-	W-
A	10	10	10	8	5	2
B	8	5	2	12	13	14

U+, V+, W+: High side phase  
U-, V-, W-: Low side phase

# STK544UC63K-E

	U(DB)	V(DB)	W(DB)
A	7	4	1
B	23	23	23

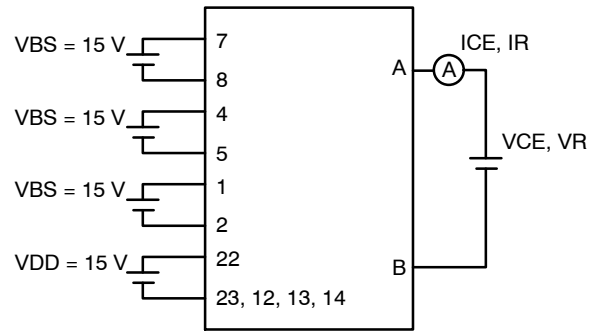

Figure 15. Test Circuit for  $I_{CE}$

- $V_{CE(sat)}$  (Test by pulse)

	U+	V+	W+	U-	V-	W-
A	10	10	10	8	5	2
B	8	5	2	12	13	14
C	15	16	17	18	19	20

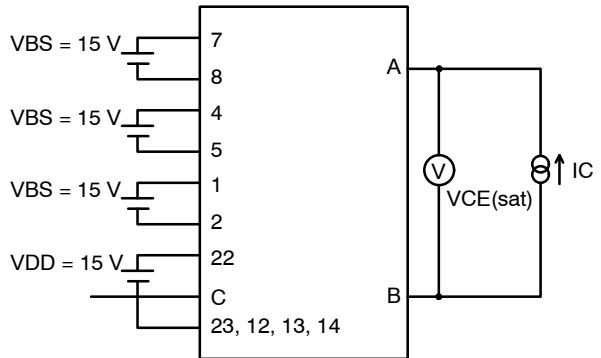

Figure 16. Test Circuit for  $V_{CE(SAT)}$

- $V_F$  (Test by pulse)

	U+	V+	W+	U-	V-	W-
A	10	10	10	8	5	2
B	8	5	2	12	13	14

	U(DB)	V(DB)	W(DB)
A	7	4	1
B	22	22	22

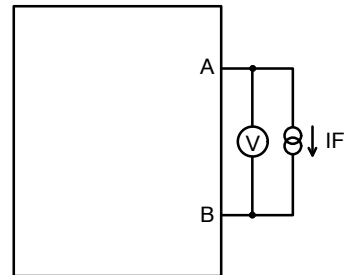

Figure 17. Test Circuit for  $V_F$

- $I_D$

	VBS U+	VBS V+	VBS W+	V <sub>DD</sub>
A	7	4	1	22
B	8	5	2	23

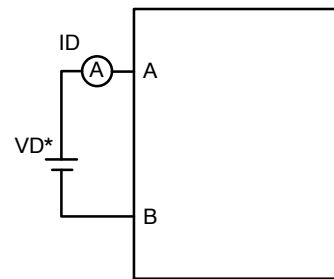

Figure 18. Test Circuit for  $I_D$

- Switching time (The circuit is a representative example of the lower side U phase.)

# STK544UC63K-E

	U+	V+	W+	U-	V-	W-
A	10	10	10	10	10	10
B	12	13	14	12	13	14
C	8	5	2	10	10	10
D	12	13	14	8	5	2
E	15	16	17	18	19	20

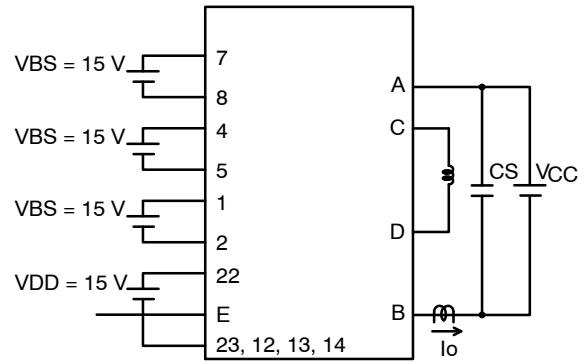
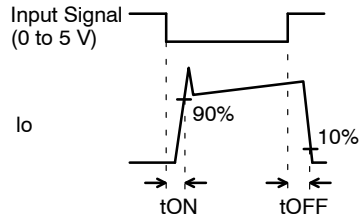

Figure 19. Test Circuit for Switching Time

# MECHANICAL CASE OUTLINE

## PACKAGE DIMENSIONS

ON Semiconductor®



SIP23, 62x21.8 FP-4  
CASE 127FC  
ISSUE O

DATE 07 JAN 2019

**NOTES:**

1. DIMENSIONING AND TOLERANCING PER. ASME Y14.5M, 2009.
2. CONTROLLING DIMENSION: MILLIMETERS
3. DIMENSION *b* and *c* APPLY TO THE PLATED LEADS AND ARE MEASURED BETWEEN 1.00 AND 2.00 FROM THE LEAD TIP.
4. POSITION OF THE LEAD IS DETERMINED AT THE ROOT OF THE LEAD WHERE IT EXITS THE PACKAGE BODY.
5. PIN 1 IDENTIFICATION IS A MIRRORED SURFACE INDENT.
6. MISSING PINS ARE 3,6,9 and 11.

DIM	MILLIMETERS		
	MIN.	NDM.	MAX.
A	4.5	5.0	5.5
A1	2.7	3.2	3.7
A2	4.5	5.0	5.5
A3	1.5	2.0	2.5
b	0.55	0.6	0.8
c	0.45	0.5	0.7
D	61.5	62.0	62.5
D1	55.5	56.0	56.5
D2	1.5	2.0	2.5
D3	45.7	46.2	46.7
D4	49.5	50.0	50.5
E	21.3	21.8	22.3
e	2.0 REF		
F	2.9	3.4	3.9
L	8.5	9.0	9.5
L1	3.8	4.3	4.8
L2	0.0	0.5	1.0

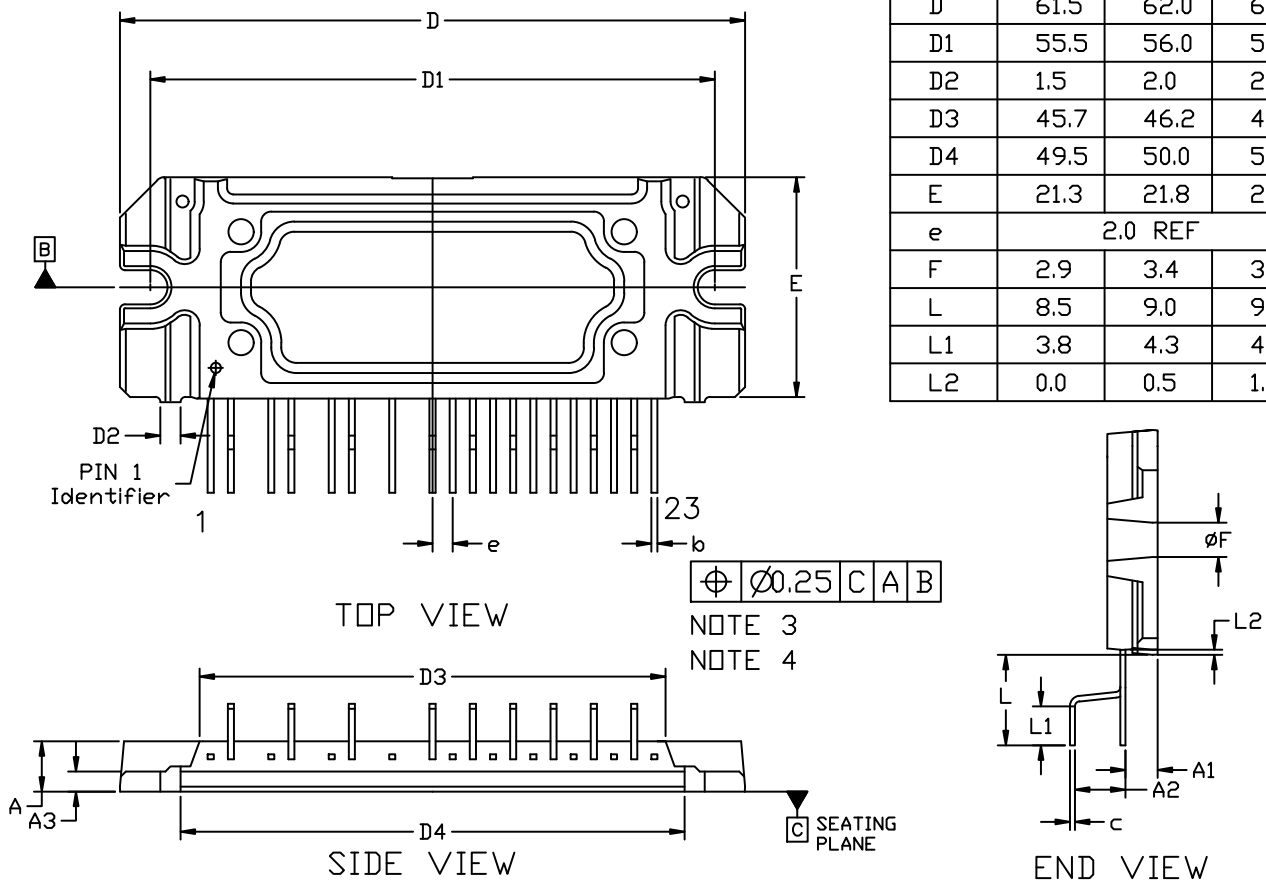

**GENERIC MARKING DIAGRAM\***

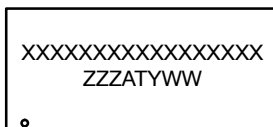

XXXX = Specific Device Code  
 ZZZ = Assembly Lot Code  
 AT = Assembly & Test Location  
 Y = Year  
 WW = Work Week

\*This information is generic. Please refer to device data sheet for actual part marking. Pb-Free indicator, "G" or microdot "•", may or may not be present. Some products may not follow the Generic Marking.

<b>DOCUMENT NUMBER:</b>	<b>98AON01973H</b>	Electronic versions are uncontrolled except when accessed directly from the Document Repository. Printed versions are uncontrolled except when stamped "CONTROLLED COPY" in red.
<b>DESCRIPTION:</b>	<b>SIP23, 62x21.8 FP-4</b>	<b>PAGE 1 OF 1</b>

ON Semiconductor and are trademarks of Semiconductor Components Industries, LLC dba ON Semiconductor or its subsidiaries in the United States and/or other countries. ON Semiconductor reserves the right to make changes without further notice to any products herein. ON Semiconductor makes no warranty, representation or guarantee regarding the suitability of its products for any particular purpose, nor does ON Semiconductor assume any liability arising out of the application or use of any product or circuit, and specifically disclaims any and all liability, including without limitation special, consequential or incidental damages. ON Semiconductor does not convey any license under its patent rights nor the rights of others.

**onsemi**, **Onsemi**, and other names, marks, and brands are registered and/or common law trademarks of Semiconductor Components Industries, LLC dba "**onsemi**" or its affiliates and/or subsidiaries in the United States and/or other countries. **onsemi** owns the rights to a number of patents, trademarks, copyrights, trade secrets, and other intellectual property. A listing of **onsemi**'s product/patent coverage may be accessed at [www.onsemi.com/site/pdf/Patent-Marking.pdf](http://www.onsemi.com/site/pdf/Patent-Marking.pdf). **onsemi** reserves the right to make changes at any time to any products or information herein, without notice. The information herein is provided "as-is" and **onsemi** makes no warranty, representation or guarantee regarding the accuracy of the information, product features, availability, functionality, or suitability of its products for any particular purpose, nor does **onsemi** assume any liability arising out of the application or use of any product or circuit, and specifically disclaims any and all liability, including without limitation special, consequential or incidental damages. Buyer is responsible for its products and applications using **onsemi** products, including compliance with all laws, regulations and safety requirements or standards, regardless of any support or applications information provided by **onsemi**. "Typical" parameters which may be provided in **onsemi** data sheets and/or specifications can and do vary in different applications and actual performance may vary over time. All operating parameters, including "Typicals" must be validated for each customer application by customer's technical experts. **onsemi** does not convey any license under any of its intellectual property rights nor the rights of others. **onsemi** products are not designed, intended, or authorized for use as a critical component in life support systems or any FDA Class 3 medical devices or medical devices with a same or similar classification in a foreign jurisdiction or any devices intended for implantation in the human body. Should Buyer purchase or use **onsemi** products for any such unintended or unauthorized application, Buyer shall indemnify and hold **onsemi** and its officers, employees, subsidiaries, affiliates, and distributors harmless against all claims, costs, damages, and expenses, and reasonable attorney fees arising out of, directly or indirectly, any claim of personal injury or death associated with such unintended or unauthorized use, even if such claim alleges that **onsemi** was negligent regarding the design or manufacture of the part. **onsemi** is an Equal Opportunity/Affirmative Action Employer. This literature is subject to all applicable copyright laws and is not for resale in any manner.

## ADDITIONAL INFORMATION

### TECHNICAL PUBLICATIONS:

Technical Library: [www.onsemi.com/design/resources/technical-documentation](http://www.onsemi.com/design/resources/technical-documentation)  
onsemi Website: [www.onsemi.com](http://www.onsemi.com)

### ONLINE SUPPORT: [www.onsemi.com/support](http://www.onsemi.com/support)

For additional information, please contact your local Sales Representative at [www.onsemi.com/support/sales](http://www.onsemi.com/support/sales)