

# Data Sheet | Item Number: 2060-451/998-404

SMD PCB terminal block; push-button; 0.75 mm<sup>2</sup>; Pin spacing 4 mm; 1-pole; Push-in CAGE CLAMP®; in tape-and-reel packaging; 0,75 mm<sup>2</sup>; white

<https://www.wago.com/2060-451/998-404>



Color: ■ white

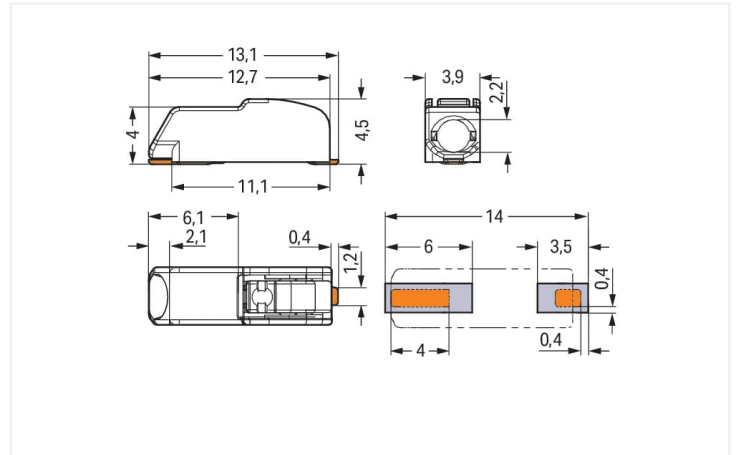

Dimensions in mm

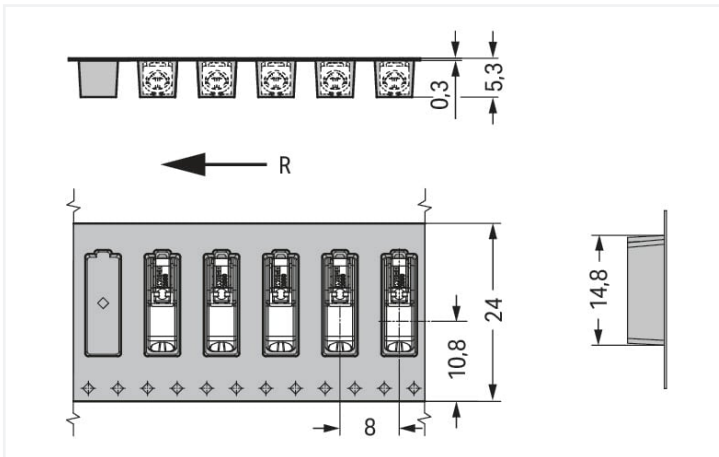

Dimensions in mm  
R = feed direction

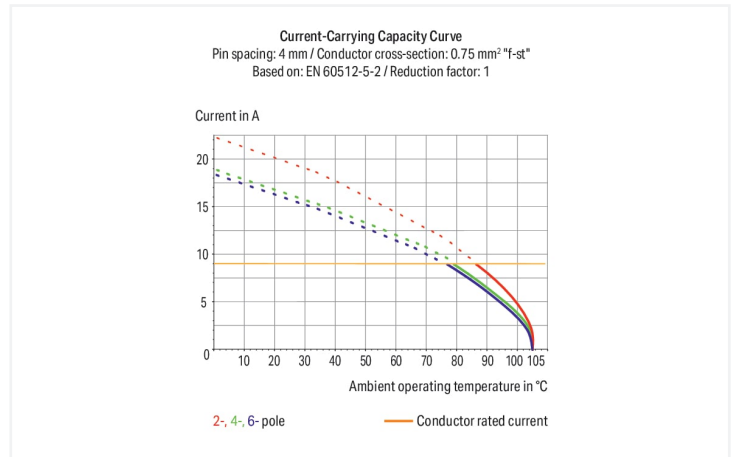

- SMD PCB terminal blocks with Push-in CAGE CLAMP® connection technology and push-buttons
- Push-in termination of solid and ferruled conductors
- Convenient termination/removal of fine-stranded conductors via push-buttons
- Just 4.5 mm tall
- Available in tape-and-reel packaging for automated assembly

## Notes

Note

Application notes:

Suitable for lead-free, reflow-soldering profiles per DIN EN 61760-1 and IEC 60068-2-58 up to max. 260°C peak temperature. Due to application-specific variables (component configuration and orientation, type of soldering machine, solder paste), trial runs are recommended to ensure product and process compatibility under actual manufacturing conditions.

Depending on reflow soldering temperatures and times, color deviations may occur. These deviations will have no impact on functionality.

Recommendation

Recommendation for stencil:

150 µm material thickness; Pattern layout identical to solder pad layout

## Electrical data

Ratings per	IEC/EN 60664-1			Ratings	
Overvoltage category	III	III	II	Approvals per	UL 1977
Pollution degree	3	2	2	Rated voltage	600 V
Nominal voltage	63 V	160 V	320 V	Rated current	9 A
Rated surge voltage	2.5 kV	2.5 kV	2.5 kV		
Rated current	9 A	9 A	9 A		

## Connection data

Clamping units	1	<b>Connection 1</b>	
Total number of potentials	1	Connection technology	Push-in CAGE CLAMP®
Number of connection types	1	Actuation type	Push-button
Number of levels	1	Solid conductor	0.2 ... 0.75 mm <sup>2</sup> / 24 ... 18 AWG
		Fine-stranded conductor	0.2 ... 0.75 mm <sup>2</sup> / 24 ... 18 AWG
		Fine-stranded conductor; with insulated ferrule	0.25 ... 0.34 mm <sup>2</sup>
		Fine-stranded conductor; with uninsulated ferrule	0.25 ... 0.34 mm <sup>2</sup>
		Strip length	7 ... 9 mm / 0.28 ... 0.35 inches
		Conductor connection direction to PCB	0°
		Pole number	1

## Physical data

Pin spacing	4 mm / 0.157 inches
Width	3.9 mm / 0.154 inches
Height	4.5 mm / 0.177 inches
Depth	13.1 mm / 0.516 inches
Reel diameter of tape-and-reel packaging	330 mm
Tape width	24 mm

## PCB contact

PCB contact	SMD
Solder pin arrangement	over the entire terminal strip (in-line)
Number of solder pins per potential	2

## Material data

Note (material data)	<a href="#">Information on material specifications can be found here</a>
Color	white
Material group	I
Insulation material (main housing)	Polyphthalamide (PPA GF)
Flammability class per UL94	V0
Clamping spring material	Copper alloy
Contact material	Copper alloy
Contact Plating	Tin
Fire load	0.009 MJ
Weight	0.2 g
MSL per J-STD 020D	1

## Environmental requirements

Limit temperature range	-60 ... +105 °C
-------------------------	-----------------

## Environmental Testing (Environmental Conditions)

Test specification Railway applications – Rolling stock – Electronic equipment	DIN EN 50155 (VDE 0115-200):2022-06
Test procedure Railway applications – Rolling stock equipment – Shock and vibration tests	DIN EN 61373 (VDE 0115-0106):2011-04
Spectrum/Installation location	Service life test, Category 1, Class A/B
Function test with noise-like vibration	Test passed according to Section 8 of the standard
Frequency	$f_1 = 5 \text{ Hz to } f_2 = 150 \text{ Hz}$ $f_1 = 5 \text{ Hz to } f_2 = 150 \text{ Hz}$
Acceleration	0.101g (highest test level used for all axes) 0.572g (highest test level used for all axes) 5g (highest test level used for all axes)
Test duration per axis	10 min. 5 h
Test directions	X, Y and Z axes X, Y and Z axes X, Y and Z axes
Monitoring for contact faults/interruptions	Passed
Voltage drop measurement before and after each axis	Passed
Simulated service life test through increased levels of noise-like vibration	Test passed according to Section 9 of the standard
Extended test scope: Monitoring for contact faults/interruptions	Passed Passed
Extended test scope: Voltage drop measurement before and after each axis	Passed Passed
Shock test	Test passed according to Section 10 of the standard
Shock form	Half sine
Shock duration	30 ms
Number of shocks per axis	3 pos. und 3 neg.
Vibration and shock stress for rolling stock equipment	Passed

## Commercial data

Product Group	33 (SMT Terminal)
eCl@ss 10.0	27-14-11-06
eCl@ss 9.0	27-14-11-06
ETIM 9.0	EC001284
ETIM 8.0	EC001284
PU (SPU)	13500 (1500) pcs
Packaging type	Box
Country of origin	CH
GTIN	4055143888172
Customs tariff number	85369010000

**Environmental Product Compliance**

RoHS Compliance Status	Compliant, No Exemption
------------------------	-------------------------

**Approvals / Certificates**

**General approvals**



Approval	Standard	Certificate Name
CCA DEKRA Certification B.V.	EN 60947	NTR NL-7724
CCA DEKRA Certification B.V.	EN 60998	NTR NL 7725/M1
CCA DEKRA Certification B.V.	EN 60838	NTR NL 2168246
CCA DEKRA Certification B.V.	EN 60947-7-4	NTR NL 7843
cURus Underwriters Laboratories Inc.	UL 1977	E45171
KEMA/KEUR DEKRA Certification B.V.	EN 60838	2168246.01
KEMA/KEUR DEKRA Certification B.V.	EN 60947	71-108183
KEMA/KEUR DEKRA Certification B.V.	EN 60998	71-109040
KEMA/KEUR DEKRA Certification B.V.	EN 60947-7-4	71-114208

**Declarations of conformity and manufacturer's declarations**



Approval	Standard	Certificate Name
EU-Declaration of Confor- mity WAGO GmbH & Co. KG	-	-
Railway WAGO GmbH & Co. KG	-	Z00004396.000
UK-Declaration of Confor- mity WAGO GmbH & Co. KG	-	-

**Downloads**

**Environmental Product Compliance**

Compliance Search	
Environmental Product Compliance 2060-451/998-404	<a href="#">↓</a>

**Documentation**

**Additional Information**

Technical Section	03.04.2019	pdf 2027.26 KB	<a href="#">↓</a>
-------------------	------------	-------------------	-------------------

CAD/CAE-Data

CAD data

2D/3D Models  
2060-451/998-404

CAE data

ZUKEN Portal  
2060-451/998-404

PCB Design

Symbol and Footprint  
via SamacSys  
2060-451/998-404

Symbol and Footprint  
via Ultra Librarian  
2060-451/998-404

1 Compatible Products

1.1 Optional Accessories

1.1.1 Board-to-board link

1.1.1.1 Board-to-board link



[Item No.: 2060-951/028-000](#)  
Board-to-Board Link; Pin spacing 4 mm; 1-pole; Length: 28 mm; white

1.1.2 Ferrule

1.1.2.1 Ferrule



[Item No.: 216-301](#)  
Ferrule; Sleeve for 0.25 mm<sup>2</sup> / AWG 24; insulated; electro-tin plated; yellow



[Item No.: 216-131](#)  
Ferrule; Sleeve for 0.25 mm<sup>2</sup> / AWG 24; uninsulated; electro-tin plated; silver-colored



[Item No.: 216-302](#)  
Ferrule; Sleeve for 0.34 mm<sup>2</sup> / 22 AWG; insulated; electro-tin plated; light turquoise



[Item No.: 216-132](#)  
Ferrule; Sleeve for 0.34 mm<sup>2</sup> / AWG 24; uninsulated; electro-tin plated

1.1.3 Tool

1.1.3.1 Operating tool



[Item No.: 206-860](#)  
Operating tool; for 2060 Series; multicoloured



[Item No.: 2060-189](#)  
Operating tool; made of insulating material; for 2060 Series; white

## Installation Notes

### Conductor termination



Insert solid conductors via push-in termination.

### Conductor termination

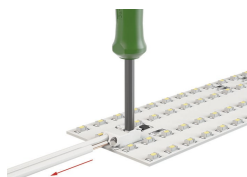

Insert/remove fine-stranded conductors by lightly pressing on push-button, e.g., via optional operating tool (206-860).



Terminal blocks can be arranged side-by-side without loss of poles.