

Rotational Absolute Magnetic Encoder Displacement Sensor



FEATURES

- Hall effect principle
- OTP (one time programmable) technology
- Plug and play
- Good magnetic immunity
- Ball bearings
- Stainless steel shaft
- Housing protected
- Material categorization: for definitions of compliance please see www.vishay.com/doc?99912



DESIGN SUPPORT TOOLS AVAILABLE



QUICK REFERENCE DATA	
Sensor type	ROTATIONAL, magnetic technology
Output type	Cable
Market appliance	Industrial, railway
Dimensions	1 1/16" (27 mm)

ELECTRICAL SPECIFICATIONS	
PARAMETER	
Voltage supply	5 V \pm 0.25 V
Current supply	\leq 20 mA at 5 V (with a load $>$ 5 k Ω)
Output	From 0.5 V _{DC} to 4.5 V _{DC}
Connection	Shielded cable
Useful electrical angle	360°
Absolute accuracy at 25 °C	\pm 1.2° on 359° (0.33 %)
Absolute accuracy at -25 °C to +85 °C	\pm 2.1° on 359° (0.58 %)
Resolution	0.09° (~ 12 bits)
Startup time	\leq 10 ms
Response time	1 ms (for an angle of 20° in 6 ms)
Dielectric strength	1000 V _{AC} / 1 min
Insulation resistance	$>$ 50 M Ω / 500 V _{DC}
Magnetic field	$<$ 10 mT with $\Delta U <$ 1°

MECHANICAL SPECIFICATIONS	
PARAMETER	
Mechanical angle	360°
Axial charge	3 N
Radial charge	3 N
Weight	\leq 50 g (with cable of 250 mm)

SAP PART NUMBERING GUIDELINES									
TYPE	MODEL	DESIGN	SIZE (mm)	TYPE	FUNCTION	ACCURACY (BITS)	RESOLUTION (BITS)	OUTPUT	PACKAGING
R = rotational	AM	E = encoder with housing	027	R	1	07	12	A = analog CW	B = box

PERFORMANCE	
PARAMETER	
Operating temperature range	-25 °C to +75 °C
Storage temperature range	-40 °C to +85 °C
Protection class	IP55
Life	50M cycles
Vibration	CEI 61373, cat1, class B
Shock	

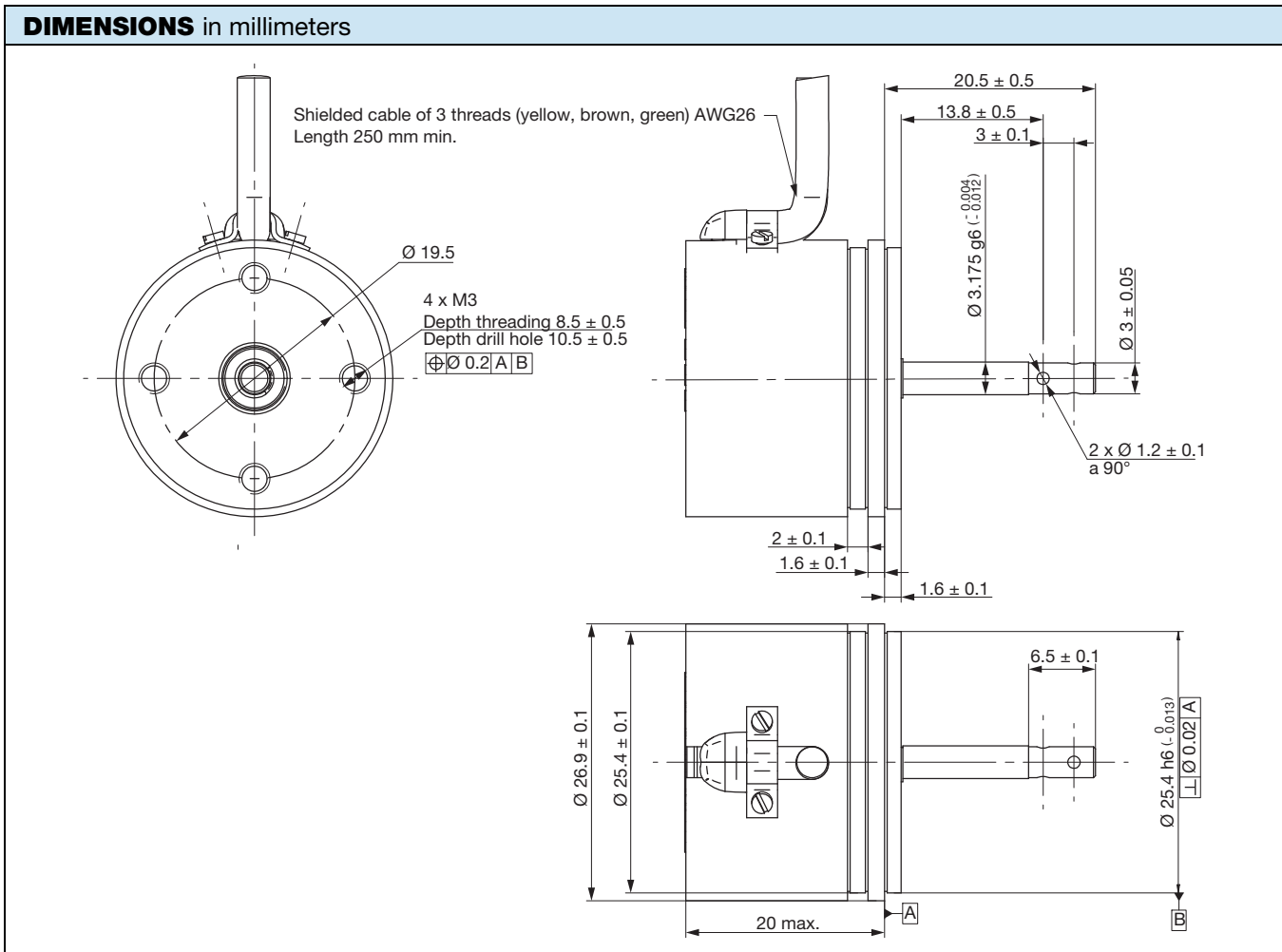
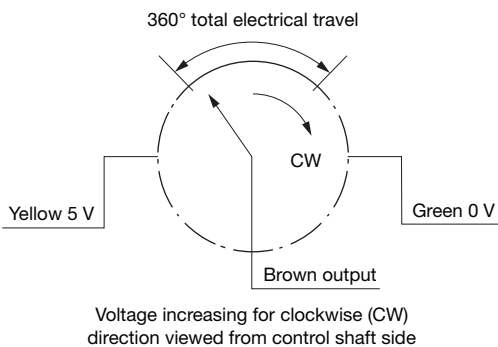
ELECTRICAL DIAGRAM

OPTIONS (on request)

- Other accuracy
- Other resolution
- Other mechanical dimensions and mechanical interfaces
- Other electrical interface (for example: PWM, SSI, ...)
- Possibility of function redundant
- Increasing of temperature range



Disclaimer

ALL PRODUCT, PRODUCT SPECIFICATIONS AND DATA ARE SUBJECT TO CHANGE WITHOUT NOTICE TO IMPROVE RELIABILITY, FUNCTION OR DESIGN OR OTHERWISE.

Vishay Intertechnology, Inc., its affiliates, agents, and employees, and all persons acting on its or their behalf (collectively, "Vishay"), disclaim any and all liability for any errors, inaccuracies or incompleteness contained in any datasheet or in any other disclosure relating to any product.

Vishay makes no warranty, representation or guarantee regarding the suitability of the products for any particular purpose or the continuing production of any product. To the maximum extent permitted by applicable law, Vishay disclaims (i) any and all liability arising out of the application or use of any product, (ii) any and all liability, including without limitation special, consequential or incidental damages, and (iii) any and all implied warranties, including warranties of fitness for particular purpose, non-infringement and merchantability.

Statements regarding the suitability of products for certain types of applications are based on Vishay's knowledge of typical requirements that are often placed on Vishay products in generic applications. Such statements are not binding statements about the suitability of products for a particular application. It is the customer's responsibility to validate that a particular product with the properties described in the product specification is suitable for use in a particular application. Parameters provided in datasheets and / or specifications may vary in different applications and performance may vary over time. All operating parameters, including typical parameters, must be validated for each customer application by the customer's technical experts. Product specifications do not expand or otherwise modify Vishay's terms and conditions of purchase, including but not limited to the warranty expressed therein.

Hyperlinks included in this datasheet may direct users to third-party websites. These links are provided as a convenience and for informational purposes only. Inclusion of these hyperlinks does not constitute an endorsement or an approval by Vishay of any of the products, services or opinions of the corporation, organization or individual associated with the third-party website. Vishay disclaims any and all liability and bears no responsibility for the accuracy, legality or content of the third-party website or for that of subsequent links.

Vishay products are not designed for use in life-saving or life-sustaining applications or any application in which the failure of the Vishay product could result in personal injury or death unless specifically qualified in writing by Vishay. Customers using or selling Vishay products not expressly indicated for use in such applications do so at their own risk. Please contact authorized Vishay personnel to obtain written terms and conditions regarding products designed for such applications.

No license, express or implied, by estoppel or otherwise, to any intellectual property rights is granted by this document or by any conduct of Vishay. Product names and markings noted herein may be trademarks of their respective owners.