

Product Overview

The TQM879028 is a digital variable gain amplifier (DVGA) featuring high linearity over the entire gain control range. This amplifier module integrates a gain block, a digital-step attenuator (DSA), and a high linearity ½ Watt amplifier into a compact 4 x 4 mm module. The internal 6-bit DSA provides a 31.5 dB gain control range in 0.5 dB steps, and is controlled with a serial peripheral interface (SPI™). The individual stages are accessible to external ports to allow for optimization of the last stage amplifier for use in any 3GPP telecom band and also allowing other functional blocks to be added in-between the stages.

The TQM879028 features variable gain from 0.5 dB to 32 dB at 2.14 GHz, +44 dBm output IP3, and +27.5 dBm P1dB while only consuming 230 mA current from a 5 V supply. The module is available in a compact 24-pin 4 x 4 mm leadless SMT package.

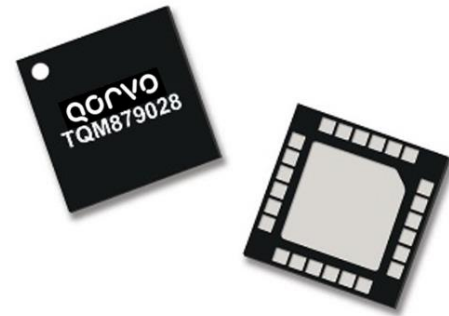

24 Pin 4x4 mm leadless SMT Package

Key Features

- 600-4000 MHz
- 32 dB Maximum Gain at 2140 MHz
- 31.5 dB Gain Range in 0.5 dB Steps
- +44 dBm Output IP3
- +27.5 dBm Output P1dB
- 1.6 dB Noise Figure
- 3-wire SPI Control Programming
- Tunable for any 3GPP telecom band

Functional Block Diagram

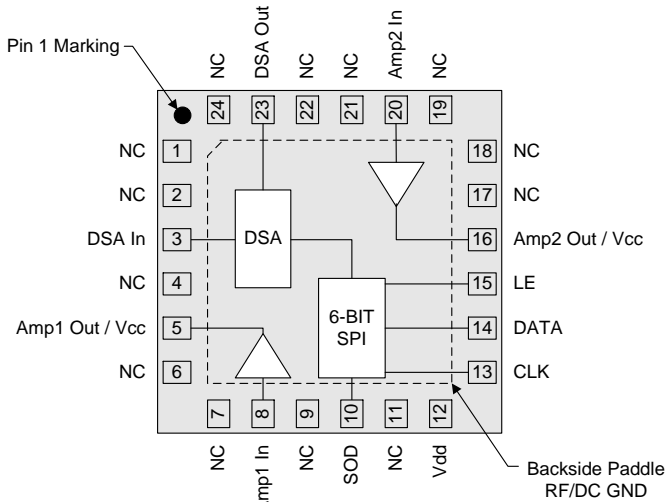

Top View

Applications

- Wireless Infrastructure
- Small cell BTS
- Pre-5G / 5G Massive MIMO systems
- TDD-based architectures

Ordering Information

Part No.	Description
TQM879028	2500 pieces on a 13" reel
TQM879028-PCB2140	2140 MHz Evaluation Board

Absolute Maximum Ratings

Parameter	Rating
Storage Temperature	-65 to 150°C
RF Input Power, CW, 50Ω, T=25°C	+12 dBm
Supply Voltage (V _{DD})	+5.5 V
Digital Input Voltage	V _{DD} + 0.5 V

Operation of this device outside the parameter ranges given above may cause permanent damage.

Recommended Operating Conditions

Parameter	Min	Typ	Max	Units
Supply Voltage (V _{DD})	4.75	5.0	5.25	V
T _{CASE}	-40		+105	°C
T _j for >10 ⁶ hours MTTF			+170	°C

Electrical specifications are measured at specified test conditions. Specifications are not guaranteed over all recommended operating conditions.

Electrical Specifications

Test conditions unless otherwise noted: V_{DD} = +5V, Temp = +25°C, matched 2140 MHz reference circuit, max. gain setting

Parameter	Conditions	Min	Typ	Max	Units
Operational Frequency Range		600		4000	MHz
Test Frequency			2140		MHz
Gain		29	32	36	dB
Gain Control Range	0.5 dB Step Size		31.5		dB
Accuracy Error		±(0.3+5% of Attenuation setting)			dB
Input Return Loss			20		dB
Output Return Loss			14		dB
Output P1dB		+26.4	+27.5		dBm
Output IP3	P _{out} = +11 dBm/tone, Δf = 1 MHz	+41	+44		dBm
Noise Figure			1.5		dB
Total Supply Current		175	230	255	mA
Amp 1 Current			86		mA
Amp 2 Current			142		mA
DSA Current			2		mA
Thermal Resistance, θ _{jc}	Junction to case			26	°C/W

Serial Control Interface

The TQM879028 has a CMOS SPI™ input compatible serial interface. This serial control interface converts the serial data input stream to parallel output word. The input is 3-wire (CLK, LE and SID) SPI™ input compatible. At power up, the serial control interface resets the DSA to the minimum gain state. The 6-bit SID (Serial Input Data) word is loaded into the register on rising edge of the CLK, MSB first. When LE is high, CLK is internally disabled.

Serial Control Timing Characteristics (Test conditions: V_{DD} = +5 V, Temp.=25°C)

Parameter	Condition	Min	Max	Units
Clock Frequency	50% Duty Cycle		10	MHz
LE Setup Time, t _{LESUP}	after last CLK rising edge	10		ns
LE Pulse Width, t _{LEPW}		30		ns
SID set-up time, t _{SDSUP}	before CLK rising edge	10		ns
SID hold-time, t _{SDHLD}	after CLK rising edge	10		ns
LE Pulse Spacing t _{LE}	LE to LE pulse spacing	630		ns
Propagation Delay t _{PLO}	LE to Parallel output valid		30	ns

Serial Control DC Logic Characteristics (Test conditions: V_{DD} = +5 V, Temp.=25°C)

Parameter	Condition	Min	Max	Units
Input Low State Voltage, V _{IL}		0	0.8	V
Input High State Voltage, V _{IH}		2.4	V _{DD}	V
Output High State Voltage, V _{OH}	On SOD pin	2.0	V _{DD}	V
Output Low State Voltage, V _{OL}	On SOD pin	0	0.8	V
Input Current, I _{IH} / I _{IL}	On SID, LE and CLK pins	-10	+10	µA

SID Control Logic Truth Table

6-Bit Control Word						Gain Relative to Maximum Gain
MSB			LSB			
D5	D4	D3	D2	D1	D0	
1	1	1	1	1	1	Maximum Gain
1	1	1	1	1	0	-0.5 dB
1	1	1	1	0	1	-1 dB
1	1	1	0	1	1	-2 dB
1	1	0	1	1	1	-4 dB
1	0	1	1	1	1	-8 dB
0	1	1	1	1	1	-16 dB
0	0	0	0	0	0	-31.5 dB

Any combination of the possible 64 states will provide a reduction in gain of approximately the sum of the bits selected.

Timing Diagram

CLK is internally disabled when LE is high

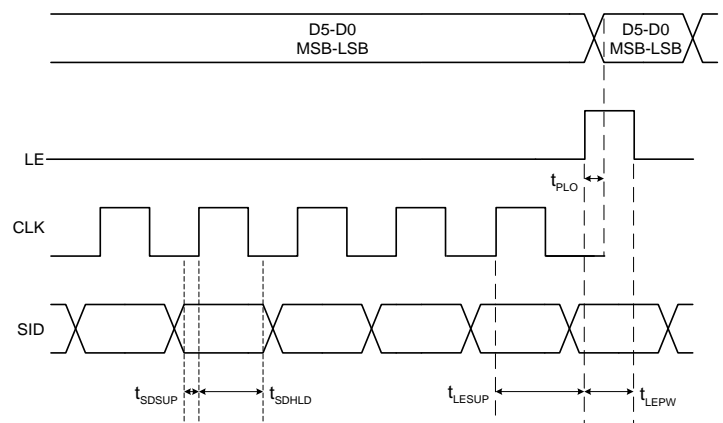

TQM879028 600 – 650 MHz Reference Design

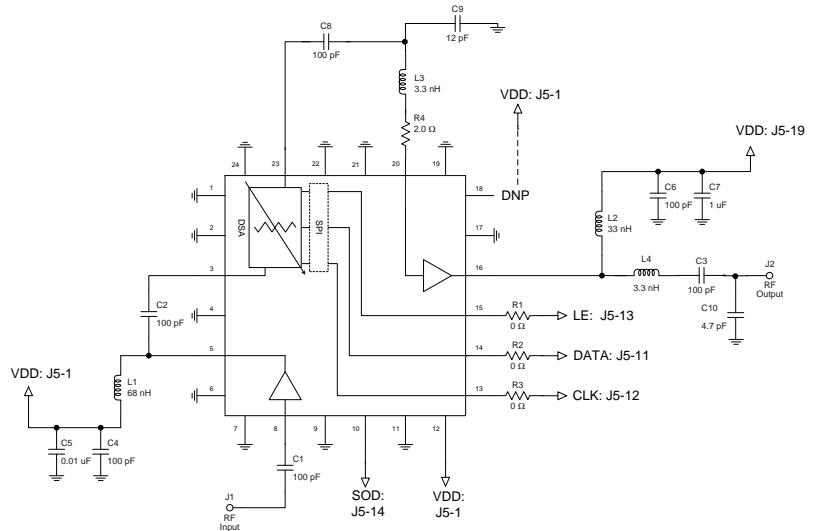
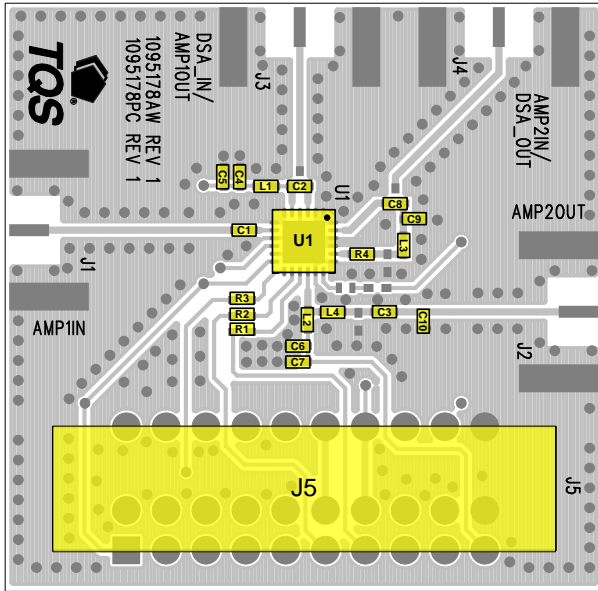

TQM879028 – 600 to 750 MHz

Notes:

1. See Evaluation Board PCB Information section for material and stack-up.
2. All components are of 0402 size.
3. Distance from the right edge of L2 to the left edge of C10: 250 mils

Bill of Material 600 – 650 MHz Reference Design

Reference Des.	Value	Description	Manuf.	Part Number
U1	n/a	1/2 W DVGA	Qorvo	TQM879028
C1, C2, C3, C4, C6, C8	100 pF	CAP, 0402, 5%. 50V. NPO/COG	various	
C5	0.01 uF	CAP, 0402, 10%, 16V, X7R	various	
C10	4.7 pF	CAP, 0402, +/- 0.1PF. 50V. NPO/COG	various	
C7	1 uF	CAP, 0402, 10%, 10V, X5R	various	
C9	12 pF	CAP, 0402, +/- 2% 50V. NPO/COG	various	
L1	68 nH	IND, 0402, 5%, ceramic core	Coilcraft	0402CS-68NXJL
L2	33 nH	IND, 0402, 5%, ceramic core	Coilcraft	0402CS-33NXJL
L3, L4	3.3 nH	IND, 0402, CHIP	Toko	LL1005-FHL3N3S
R4	2.0 Ω	RES, 0402, +/- 1%, 1/10W	various	
R1, R2, R3	0 Ω	RES, 0402, CHIP	various	

Typical Performance 600 – 650 MHz Reference Design

Test conditions unless otherwise noted: $V_{DD} = +5V$, $Temp = +25^{\circ}C$, DSA at max. gain setting

Parameter	Conditions	Typical Values			Units
Frequency		600	625	650	MHz
Gain		43.6	43.4	43.2	dB
Input Return Loss		13	17	20	dB
Output Return Loss		12	9	7	dB
Output P1dB		+26.6	+27.1	+27.4	dBm
Output IP3	$P_{out} = +13$ dBm/tone, $\Delta f = 1$ MHz	+41.8	+41.0	+39.5	dBm
LTE Chan. Power ⁽¹⁾	-50 dBc ACLR	+17.7	+17.8	+17.6	dBm

Notes:

1. ACLR test set-up: 1 CH, 20 MHz BW, LTE E-TM1.1, 9.5 dB PAR at 0.01% Probability

Performance Plots 600 – 650 MHz Reference Design

Test conditions unless otherwise noted: $V_{DD} = +5V$, $Temp = +25^{\circ}C$, DSA at max. gain setting

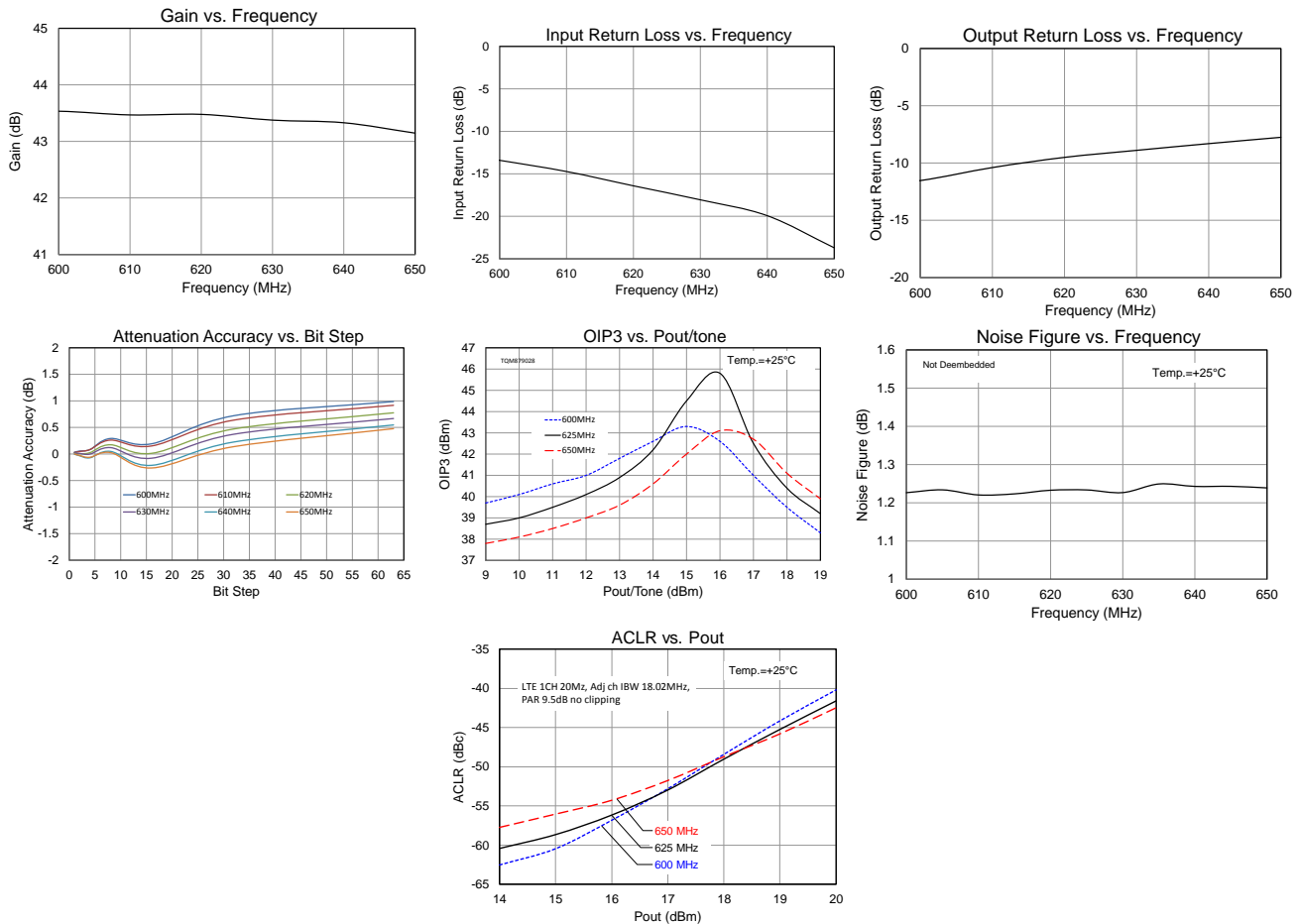

TQM879028 700 – 800 MHz Reference Design

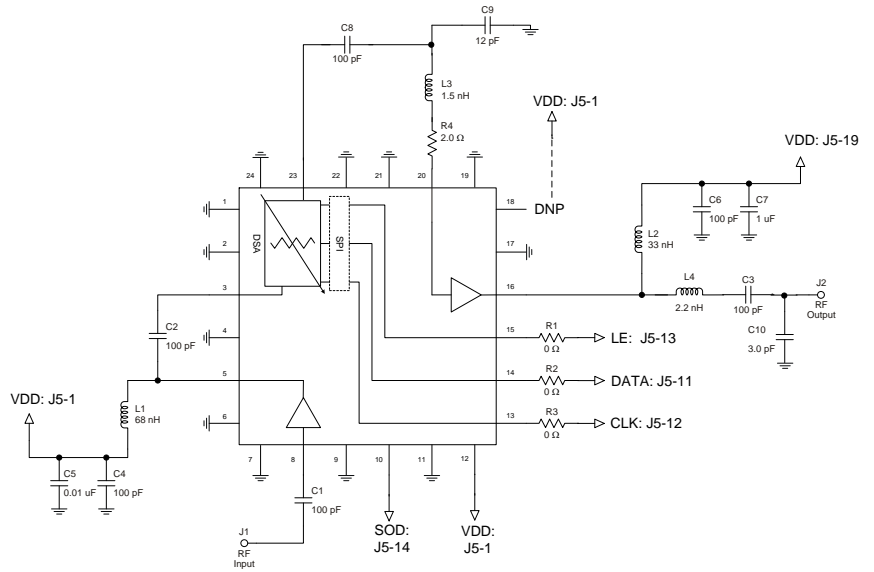
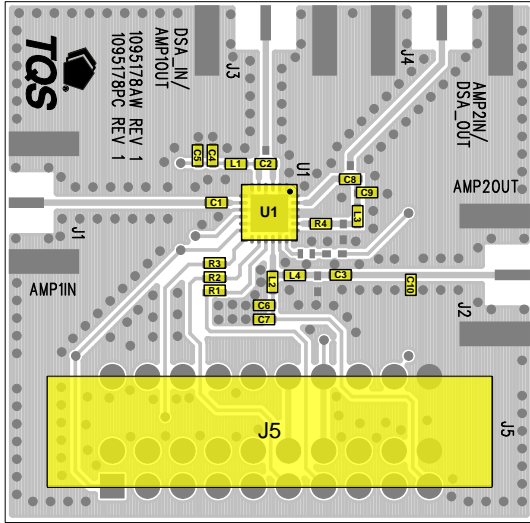

TQM879028 – 700 to 800 MHz

Notes:

1. See Evaluation Board PCB Information section for PCB material and stack-up.
2. Components are 0402 unless specified otherwise
3. 0 Ohm resistors may be replaced with 50 Ohm traces in the target application layout.
4. Critical component placement:
 - a. Distance from the right edge of L2 to the left edge of C10: 470 mils

Bill of Material 700 – 800 MHz Reference Design

Reference Des.	Value	Description	Manuf.	Part Number
n/a	n/a	Printed Circuit Board	Qorvo	
U1	n/a	TQM879028 Sample	Qorvo	TQM879028
L1	68 nH	Ind, 0402, 5%	various	
L2	33 nH	Ind, 0402, 5%	various	
L3	1.5 nH	Ind, 0402, 5%	various	
L4	2.2 nH	Ind, 0402, 5%	various	
R1, R2, R3	0 Ω	RES, 0402, CHIP	various	
R4	2.0 Ω	RES, 0402, 5%, 1/16W, CHIP	various	
C9	12 pF	CAP, 0402, 2%, 50V, NPO/COG	various	
C10	3.0 pF	CAP, 0402, +/-0.1, 50V, NPO/COG	various	
C1, C2, C3, C4, C6, C8	100 pF	CAP, 0402, 5%, 50V, NPO/COG	various	
C5	0.01 uF	CAP, 0402, 10%, 16V, X7R	various	
C7	1 uF	CAP, 0402, 10%, 10V, X5R	various	
J5	n/a	Conn, Receptacle, 20POS., 100RT/A, DUAL	Tyco	5-532956-3

Typical Performance 700 – 800 MHz Reference Design

Test conditions unless otherwise noted: $V_{DD}=+5\text{ V}$, $I_{DD}=230\text{ mA}$ (typ.), $\text{Temp}=+25^\circ\text{C}$, maximum gain state

Parameter	Conditions	Typical Value			Units
Frequency		700	750	800	MHz
Gain		42.8	42.7	42.3	dB
Gain Control Range		30.2	30.5	30.7	dB
Input Return Loss		11	14	20	dB
Output Return Loss		14	9	7	dB
Output P1dB		+26.6	+27.0	+27.3	dBm
Output IP3	$P_{out}= +13\text{dBm}/\text{tone}$, $\Delta f= 1\text{ MHz}$	+41.2	+41.2	+39.3	dBm
Noise Figure		1.2	1.2	1.2	dB
Total Device Current		230			mA

Performance Plots 700 – 800 MHz Reference Design

Test conditions unless otherwise noted: $V_{DD}=+5\text{ V}$, $I_{DD}=230\text{ mA}$ (typ.), $\text{Temp}=+25^\circ\text{C}$, maximum gain state

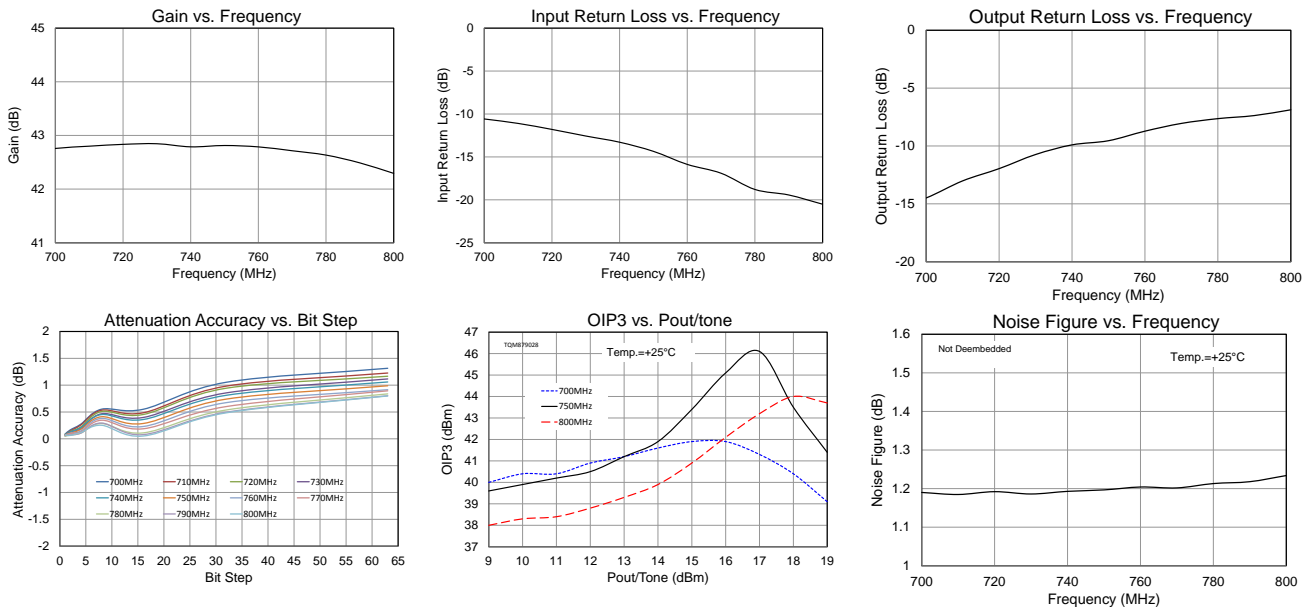

TQM879028 869 – 960 MHz Reference Design

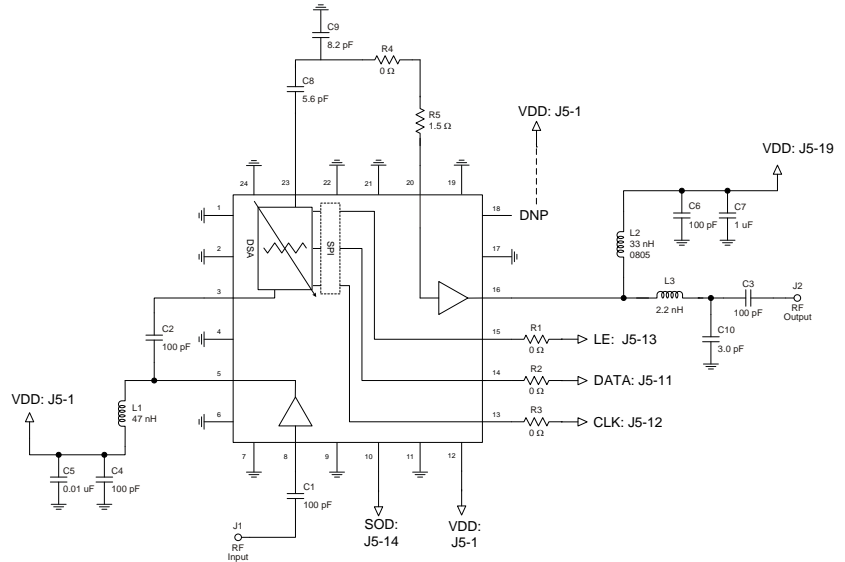
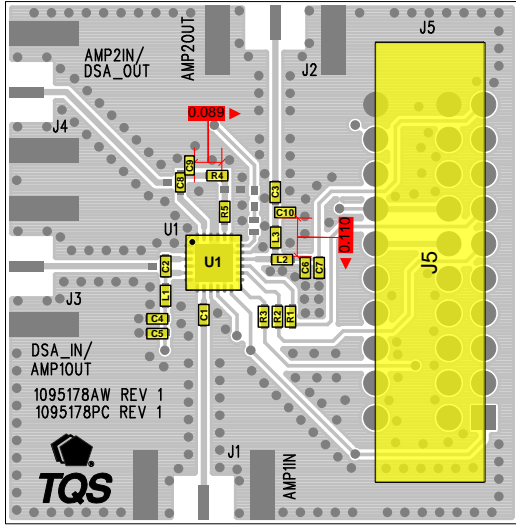

Notes:

5. See Evaluation Board PCB Information section for PCB material and stack-up.
6. Components are 0402 unless specified otherwise
7. 0 Ohm resistors may be replaced with 50 Ohm traces in the target application layout.
8. Critical component placement:
 - b. Distance from the edge of L2 to the edge of C10: 110 mils
 - c. Distance from the edge of Tx line to the edge of C9: 130 mils

Bill of Material 869 – 960 MHz Reference Design

Reference Des.	Value	Description	Manuf.	Part Number
N/A	N/A	Printed Circuit Board	Qorvo	1095178
U1	N/A	Variable Gain Amplifier	Qorvo	TQM879028
L1	47 nH	IND, 0402, 5%	various	
L2	33 nH	IND, 0402, 5%	various	
L3	2.2 nH	IND, 0402, 5%, 0.8 GHz	various	
R1, R2, R3, R4	0 Ω	RES, 0402, CHIP	various	
R5	1.5 Ω	RES, 0402, 1%, 1/16W, CHIP	various	
C10	3.0 pF	CAP, 0402, ± 0.1 pF, 50V, U-Series	AVX	04025U3R0BAT2A
C8	5.6 pF	CAP, 0402, ± 0.1 pF, 50V, U-Series	AVX	04025U5R6BAT2A
C9	8.2 pF	CAP, 0402, ± 0.1 pF, 50V, U-Series	AVX	04025U8R2BAT2A
C1, C2, C3, C4, C6	100 pF	CAP, 0402, 5%, 50V, NPO/COG	various	
C5	0.01 uF	CAP, 0402, 10%, 16V, X7R	various	
C7	1 uF	CAP, 0402, 10%, 10V, X5R	various	
J5	n/a	Conn, Receptacle, 20POS., 100RT/A, Dual	Tyco	5-532956-3

Typical Performance 869 – 960 MHz Reference Design

Test conditions unless otherwise noted: $V_{DD}=+5\text{ V}$, $I_{DD}=230\text{ mA}$ (typ.), $\text{Temp}=+25^\circ\text{C}$, maximum gain state

Parameter	Conditions	Typical Value			Units
Frequency		869	915	960	MHz
Gain		41.4	41.4	41.3	dB
Input Return Loss		11.2	13.1	16.2	dB
Output Return Loss		10.8	7.9	5.8	dB
Output P1dB		+26.8	+27.3	+27.6	dBm
Output IP3	$P_{out} = +11\text{ dBm/tone}$, $\Delta f = 1\text{ MHz}$	+40.7	+41.0	+40.4	dBm

Performance Plots 869 – 960 MHz Reference Design

Test conditions unless otherwise noted: $V_{DD}=+5\text{ V}$, $I_{DD}=230\text{ mA}$ (typ.), $\text{Temp}=+25^\circ\text{C}$, maximum gain state

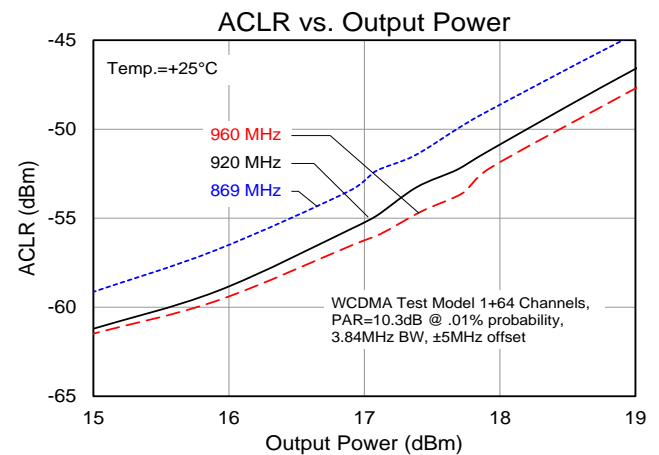
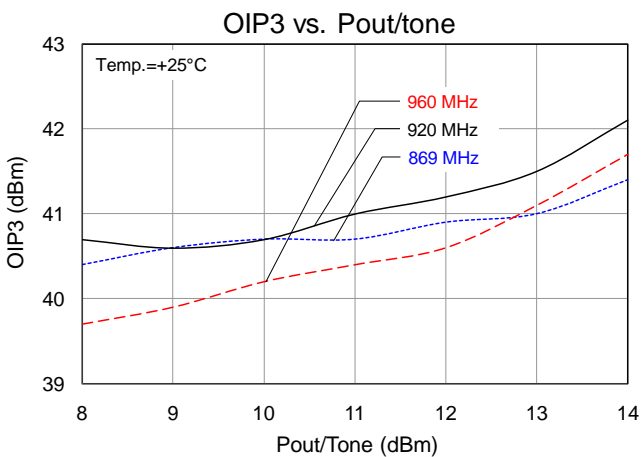
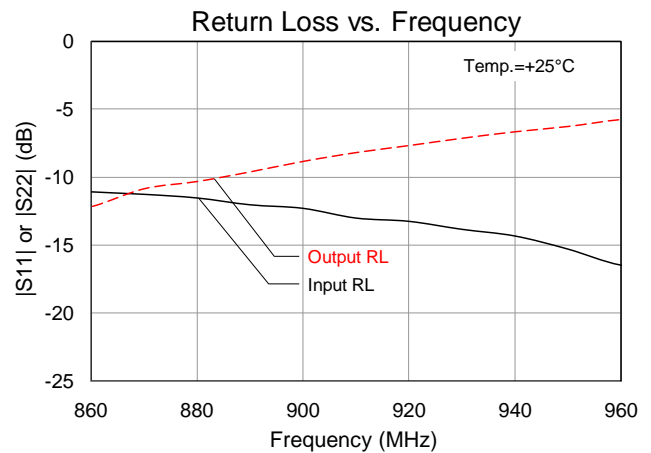
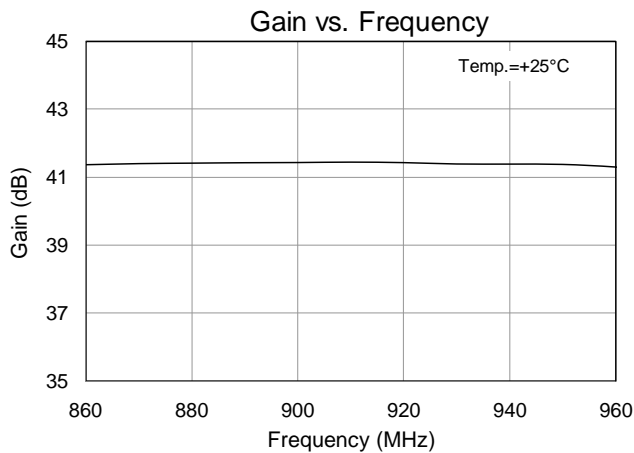

TQM879028 1805 – 1880 MHz Reference Design

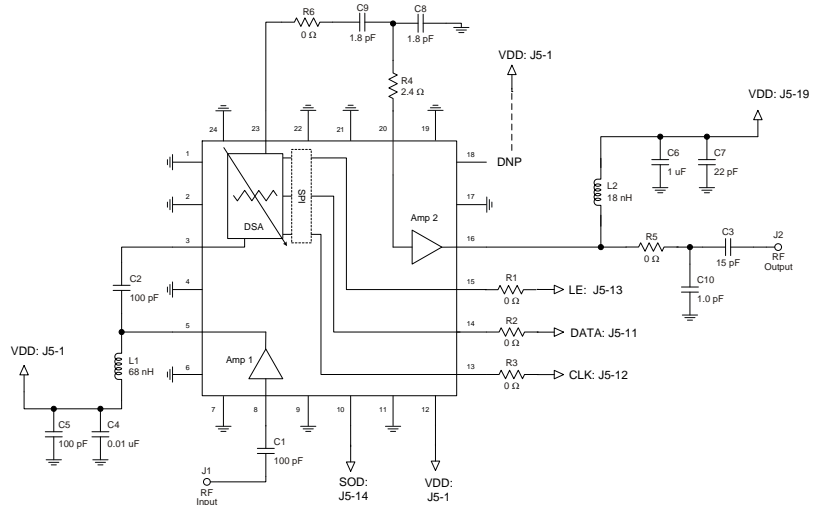
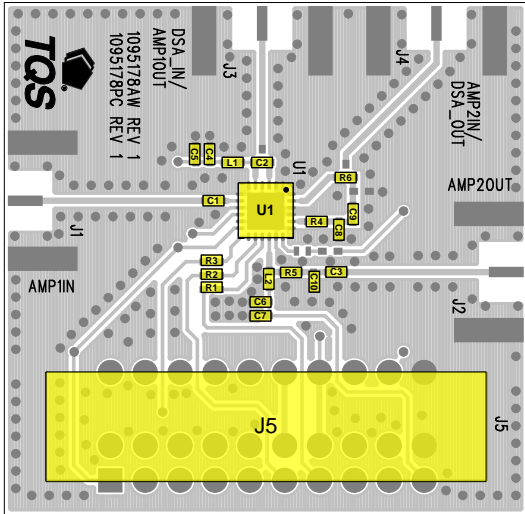

TQM879028 – 1805-1880 MHz

Notes:

1. See Evaluation Board PCB Information section for PCB material and stack-up.
2. Components are 0402 unless specified otherwise
3. 0 Ohm resistors may be replaced with 50 Ohm traces in the target application layout.

Bill of Material 1805 – 1880 MHz Reference Design

Reference Des.	Value	Description	Manuf.	Part Number
n/a	n/a	Printed Circuit Board	Qorvo	1095178
U1	n/a	TQM879028 Sample	Qorvo	TQM879028
L1	68 nH	Ind, 0402, 5%	various	
L2	18 nH	Ind, 0402, 5%	various	
R1, R2, R3, R5, R6	0 Ω	RES, 0402, CHIP	various	
R4	2.4 Ω	RES, 0402, 5%, 1/16W, CHIP	various	
C1, C2, C5	100 pF	CAP, 0402, 5%, 50V, NPO/COG	various	
C10	1.0 pF	CAP, 0402, ± 0.1 pF, 50V, NPO, U-Series	AVX	04025U1R0BAT2A
C3	15 pF	CAP, 0402, 5%, 50V, NPO/COG	various	
C8, C9	1.8 pF	CAP, 0402, ± 0.1 pF, 50V, NPO, U-Series	AVX	04025U1R8BAT2A
C7	22 pF	CAP, 0402, 5%, 50V, NPO/COG	various	
C4	0.01 uF	CAP, 0402, 10%, 16V, X7R	various	
C6	1 uF	CAP, 0402, 10%, 10V, X5R	various	

Typical Performance 1805 – 1880 MHz Reference Design

Test conditions unless otherwise noted: $V_{DD}=+5\text{ V}$, $I_{DD}=230\text{ mA}$ (typ.), $\text{Temp}=+25^\circ\text{C}$, maximum gain state

Parameter	Conditions	Typical Value			Units
Frequency		1805	1842	1880	MHz
Gain		34.3	34.3	34.3	dB
Gain Control Range		32.2	32.1	32.0	dB
Input Return Loss		20	20	20	dB
Output Return Loss		9	9	9	dB
Output P1dB		+27.6	+27.6	+27.6	dBm
Output IP3	$P_{out}= +11\text{ dBm}/\text{tone}$, $\Delta f= 1\text{ MHz}$	+42.3	+42.8	+42.9	dBm
Noise Figure		1.4	1.4	1.4	dB
Total Device Current		230			mA

Performance Plots 1805 – 1880 MHz Reference Design

Test conditions unless otherwise noted: $V_{DD}=+5\text{ V}$, $I_{DD}=230\text{ mA}$ (typ.), $\text{Temp}=+25^\circ\text{C}$, maximum gain state

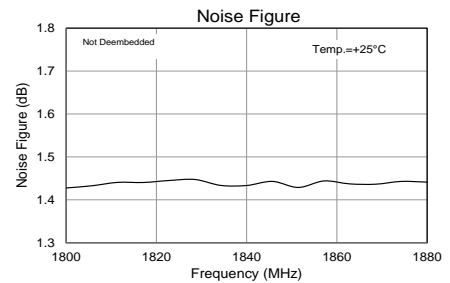
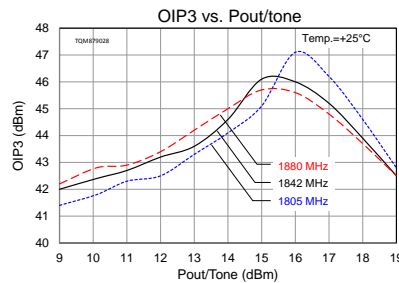
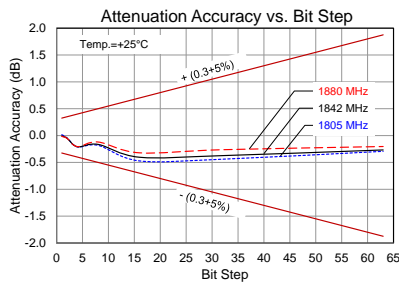
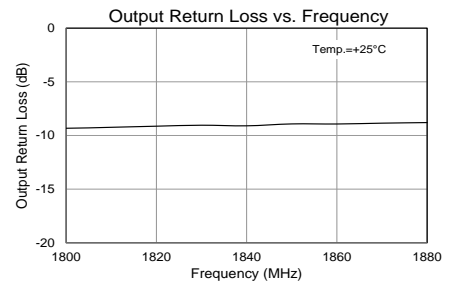
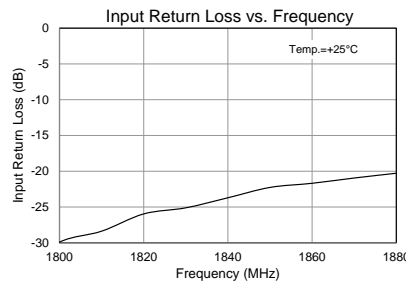
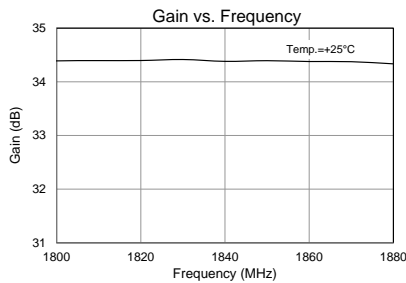

TQM879028-PCB2140 Evaluation Board

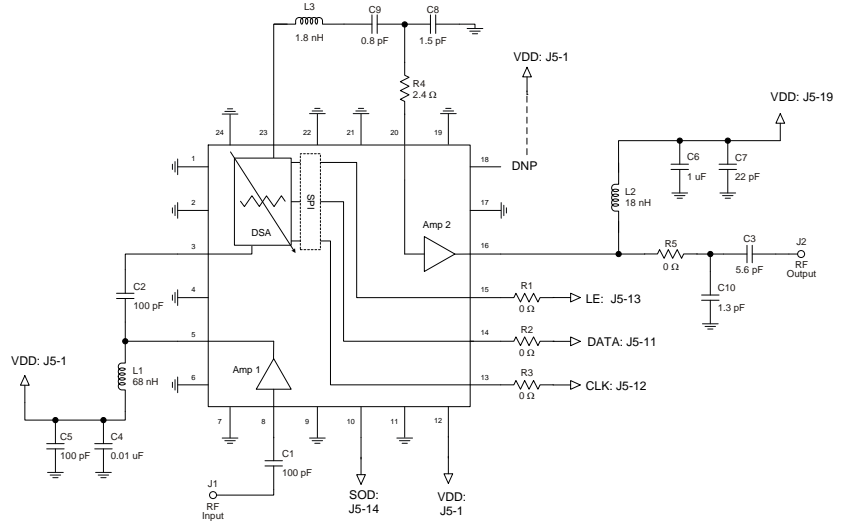
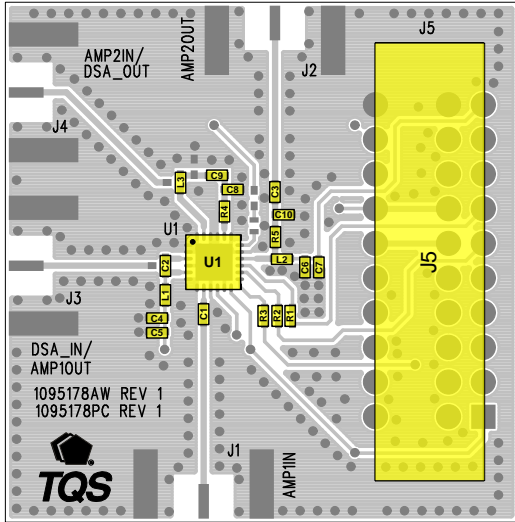

Notes:

1. See Evaluation Board PCB Information section for PCB material and stack-up.
2. Components are 0402 unless specified otherwise
3. 0 Ohm resistors may be replaced with 50 Ohm traces in the target application layout.

Bill of Material – TQM879028-PCB2140

Reference Des.	Value	Description	Manuf.	Part Number
N/A	N/A	Printed Circuit Board	Qorvo	1095178
U1	N/A	Variable Gain Amplifier	Qorvo	TQM879028
L1	68 nH	Inductor, 0402	various	
L2	18 nH	Inductor, 0402	various	
L3	1.8 nH	Inductor, 0402	various	
R1, R2, R3, R5	0 Ω	Resistor, 0402	various	
R4	2.4 Ω	Resistor, 0402	various	
C1,C2,C5	100 pF	Capacitor, 0402	various	
C3	5.6 pF	Capacitor, 0402	various	
C9	0.8 pF	CAP, 0402, ± 0.1 pF, 50V, U-Series	AVX	04025U0R8BAT2A
C10	1.3 pF	CAP, 0402, ± 0.1 pF, 50V, U-Series	AVX	04025U1R3BAT2A
C8	1.5 pF	CAP, 0402, ± 0.1 pF, 50V, U-Series	AVX	04025U1R5BAT2A
C7	22 pF	Capacitor, 0402	various	
C4	0.01 uF	Capacitor, 0402	various	
C6	1 uF	Capacitor, 0402	various	
J5	n/a	Conn, Receptacle, 20POS., 100RT/A, Dual	Tyco	5-532956-3

Typical Performance – TQM879028-PCB2140

Test conditions unless otherwise noted: $V_{DD}=+5\text{ V}$, $I_{DD}=230\text{ mA}$ (typ.), $\text{Temp}=+25^\circ\text{C}$, maximum gain state

Parameter	Conditions	Typical Value			Units
Frequency		2110	2140	2170	MHz
Gain		32	32	32	dB
Input Return Loss		20.1	18.0	16.8	dB
Output Return Loss		13.1	12.6	12.6	dB
Output P1dB		+27.7	+27.6	+27.4	dBm
Output IP3	$P_{out} = +11\text{ dBm/tone}$, $\Delta f = 1\text{ MHz}$	+45	+44	+43	dBm
Noise figure		1.6	1.6	1.6	dB

Performance Plots – TQM879028-PCB2140

Test conditions unless otherwise noted: $V_{DD}=+5\text{ V}$, $I_{DD}=230\text{ mA}$ (typ.), $\text{Temp}=+25^\circ\text{C}$, maximum gain state

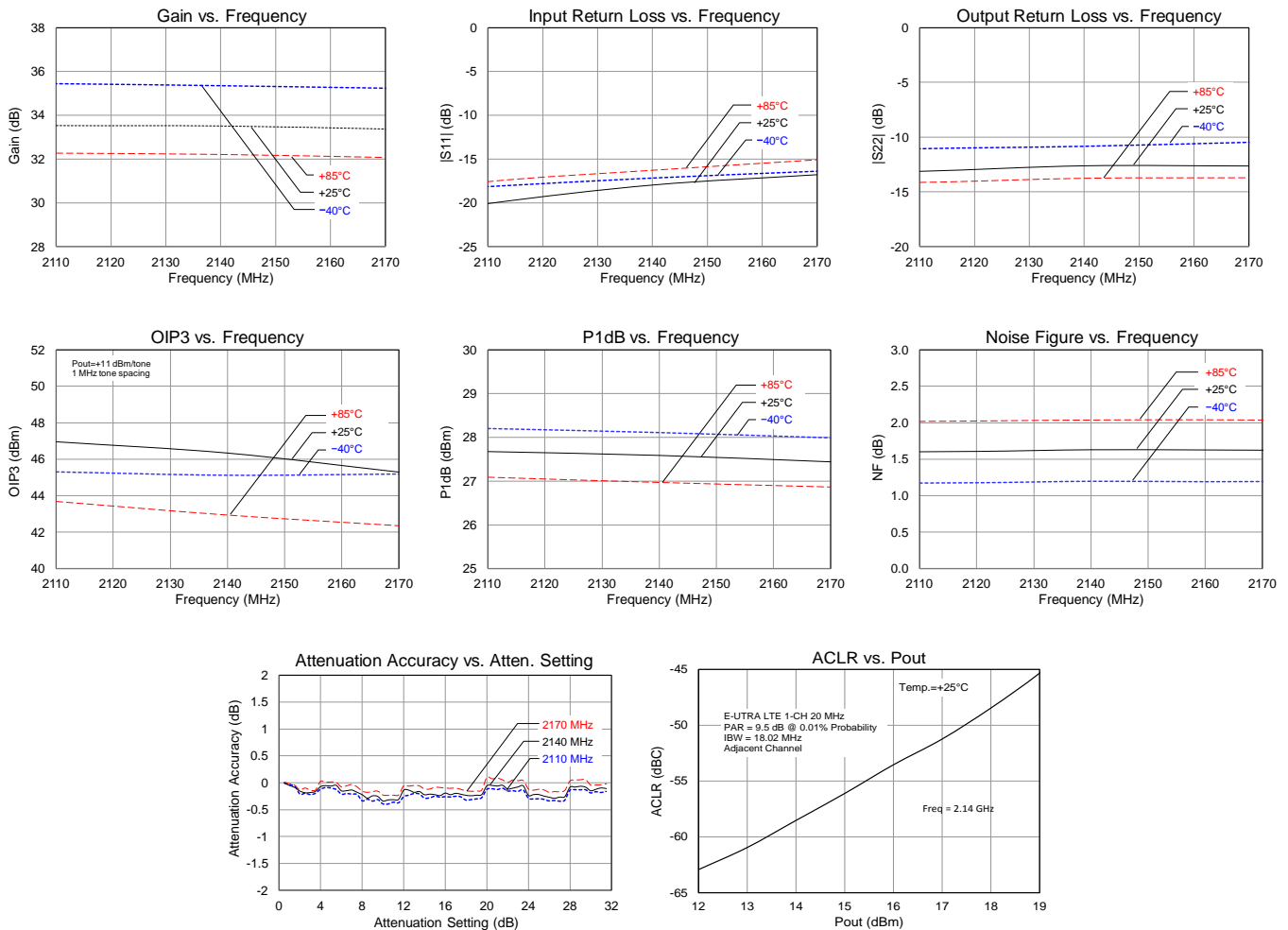

TQM879028 1800 – 2200 MHz Reference Design

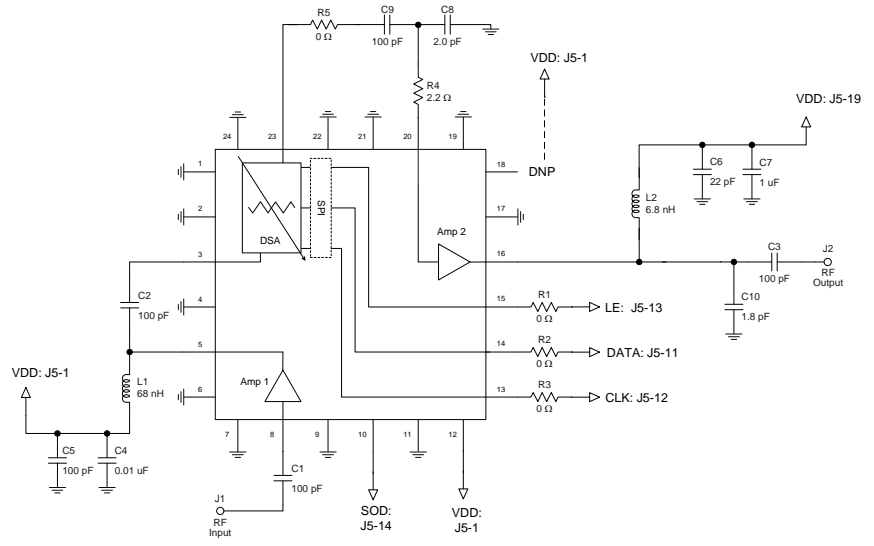
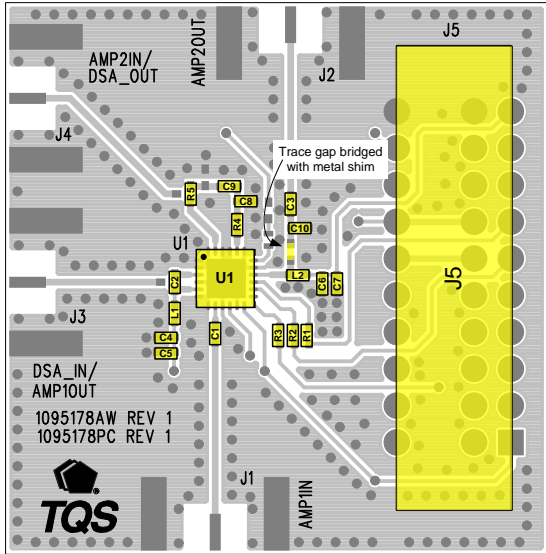

Notes:

1. Notes:
2. See Evaluation Board PCB Information section for PCB material and stack-up.
3. Components are 0402 unless specified otherwise
4. 0 Ohm resistors may be replaced with 50 Ohm traces in the target application layout.

Bill of Material – 1800 – 2200 MHz Reference Design

Reference Des.	Value	Description	Manuf.	Part Number
N/A	N/A	Printed Circuit Board	Qorvo	1095178
U1	N/A	Variable Gain Amplifier	Qorvo	TQM879028
L1	68 nH	Inductor, 0402	various	
L2	6.8 nH	Inductor, 0402	various	
R1, R2, R3, R5	0 Ω	Resistor, 0402	various	
R4	2.2 Ω	Resistor, 0402	various	
C1, C2, C3, C5, C9	100 pF	Capacitor, 0402	various	
C10	1.8 pF	Capacitor, 0402	various	
C8	2.0 pF	Capacitor, 0402	various	
C6	22 pF	Capacitor, 0402	various	
C4	0.01 uF	Capacitor, 0402	various	
C7	1 uF	Capacitor, 0402	various	
J5	n/a	Conn, Receptacle, 20POS., 100RT/A, Dual	Tyco	5-532956-3

Typical Performance 1800 – 2200 MHz Reference Design

Test conditions unless otherwise noted: $V_{DD}=+5\text{ V}$, $I_{DD}=230\text{ mA}$ (typ.), $Temp.=+25\text{ }^{\circ}\text{C}$, maximum gain state

Parameter	Conditions	Typical Value			Units
		1800	2000	2200	
Frequency		1800	2000	2200	MHz
Gain		34.1	33.1	32.8	dB
Input Return Loss		10.6	10.9	13.6	dB
Output Return Loss		8.4	11.0	13.4	dB
Output P1dB		+27.7	+27.7	+27.7	dBm
Output IP3	$P_{out} = +12\text{ dBm/tone}$, $\Delta f = 1\text{ MHz}$	+42.7	+46.2	+48.4	dBm

Performance Plots 1800 – 2200 MHz Reference Design

Test conditions unless otherwise noted: $V_{DD}=+5\text{ V}$, $I_{DD}=230\text{ mA}$ (typ.), $Temp.=+25\text{ }^{\circ}\text{C}$, maximum gain state

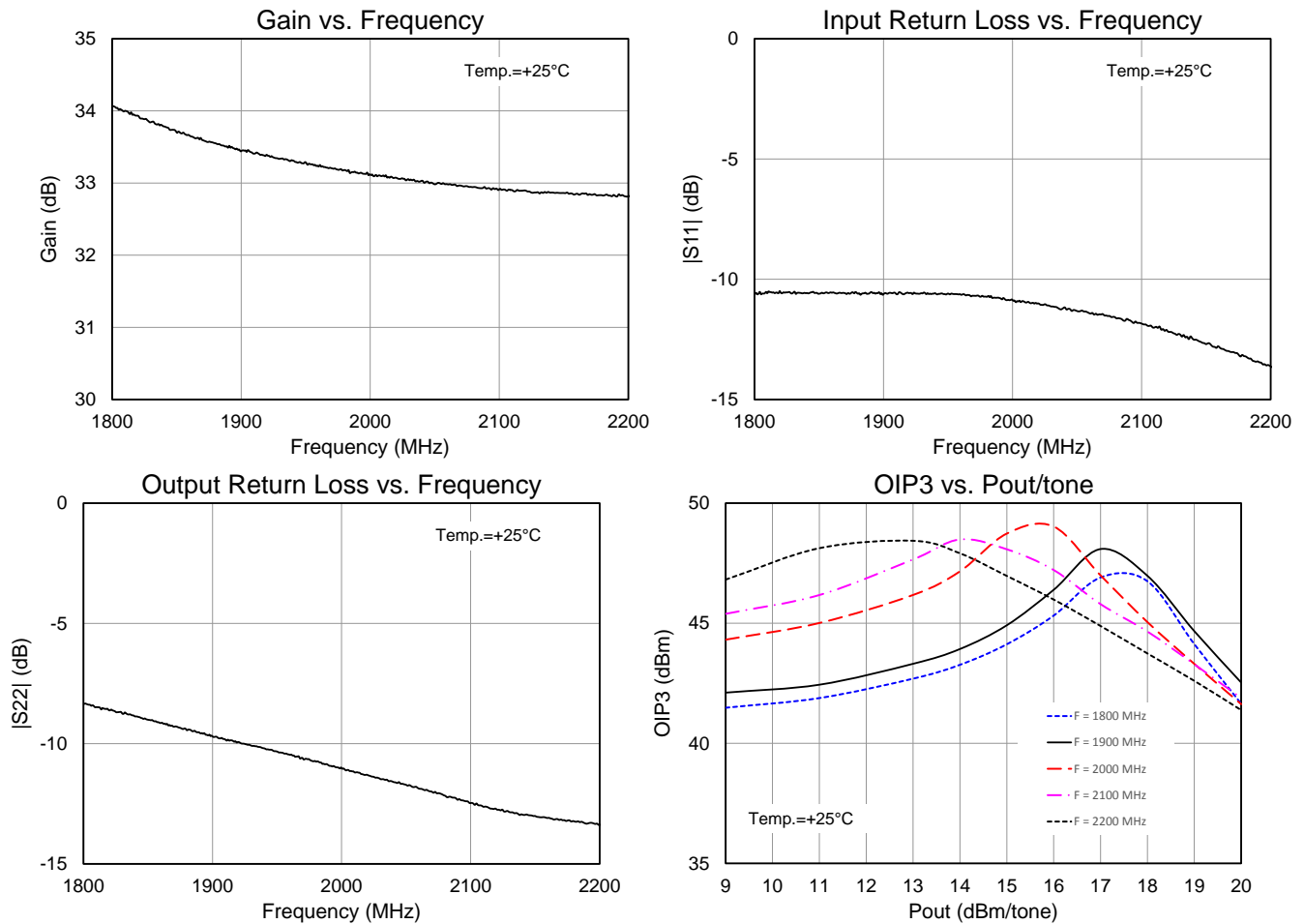

TQM879028 2500 – 2700 MHz Reference Design

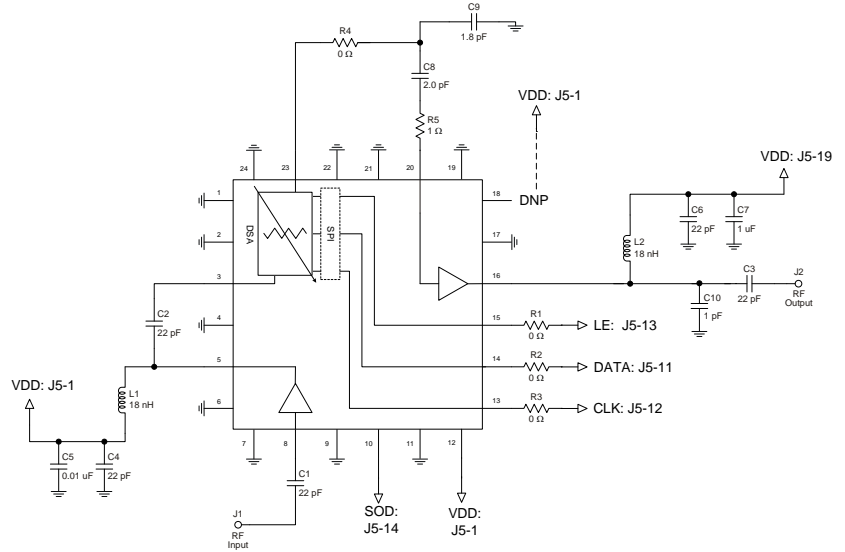
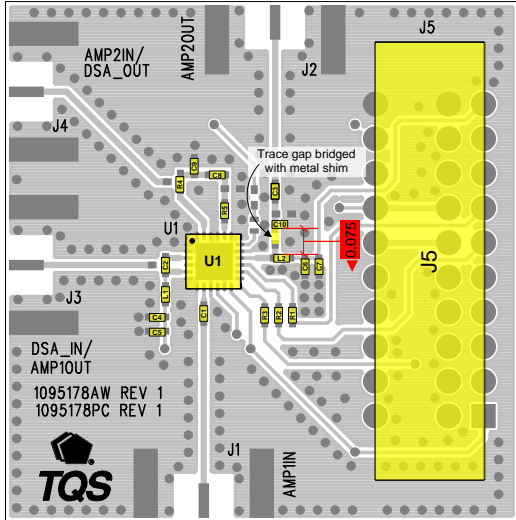

Notes:

1. Notes:
2. See Evaluation Board PCB Information section for PCB material and stack-up.
3. Components are 0402 unless specified otherwise
4. 0 Ohm resistors may be replaced with 50 Ohm traces in the target application layout.
5. Critical component placement: Distance from the edge of L2 to the edge of C10: 75 mils (9.2 °at 2600 MHz)

Bill of Material 2500 – 2700 MHz Reference Design

Reference Des.	Value	Description	Manuf.	Part Number
N/A	N/A	Printed Circuit Board	Qorvo	1095178
U1	N/A	Variable Gain Amplifier	Qorvo	TQM879028
L1, L2	18 nH	Ind, 0402, 5%	various	
R1, R2, R3, R4	0 Ω	RES, 0402, CHIP	various	
R5	1 Ω	RES, 0402, 5%, 1/16W, CHIP	various	
C10	1 pF	CAP, 0402, ± 0.1 pF, 50V, NPO, U-Series	AVX	04025U1R0BAT2A
C9	1.8 pF	CAP, 0402, ± 0.1 pF, 50V, NPO, U-Series	AVX	04025U1R8BAT2A
C8	2 pF	CAP, 0402, ± 0.1 pF, 50V, NPO, U-Series	AVX	04025U2R0BAT2A
C1, C2, C3, C4, C6	22 pF	CAP, 0402, 5%, 50V, NPO/COG	various	
C5	0.01 uF	CAP, 0402, 10%, 16V, X7R	various	
C7	1 uF	CAP, 0402, 10%, 10V, X5R	various	
J5	n/a	Conn, Receptacle, 20POS., 100RT/A, DUAL	Tyco	5-532956-3

Typical Performance 2500 – 2700 MHz Reference Design

Test conditions unless otherwise noted: $V_{DD}=+5\text{ V}$, $I_{DD}=230\text{ mA}$ (typ.), $Temp.=+25\text{ }^{\circ}\text{C}$, maximum gain state

Parameter	Conditions	Typical Value			Units
Frequency		2500	2600	2700	MHz
Gain		30.5	30.9	31.0	dB
Input Return Loss		12.9	13.8	15.7	dB
Output Return Loss		10.2	10.3	9.7	dB
Output P1dB		+27.9	+27.8	+27.5	dBm
Output IP3	$P_{out} = +11\text{ dBm/tone}$, $\Delta f = 1\text{ MHz}$	+46.5	+45.5	+44	dBm

Performance Plots 2500 – 2700 MHz Reference Design

Test conditions unless otherwise noted: $V_{DD}=+5\text{ V}$, $I_{DD}=230\text{ mA}$ (typ.), $Temp.=+25\text{ }^{\circ}\text{C}$, maximum gain state

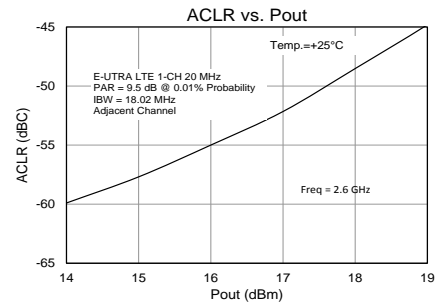
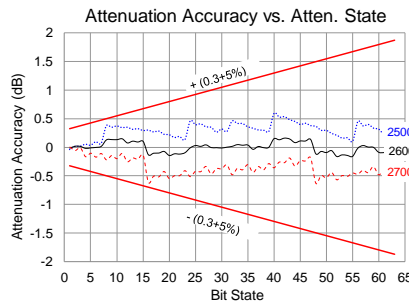
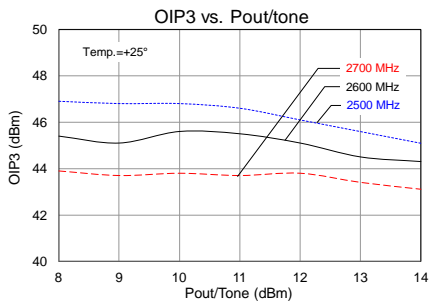
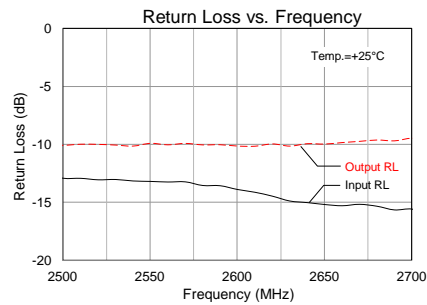
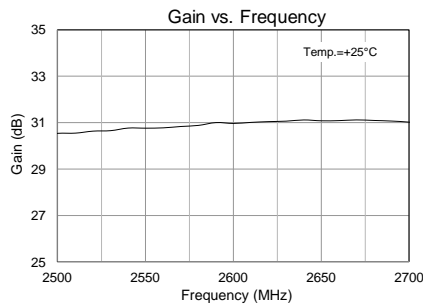

TQM879028 3400 – 3600 MHz Reference Design

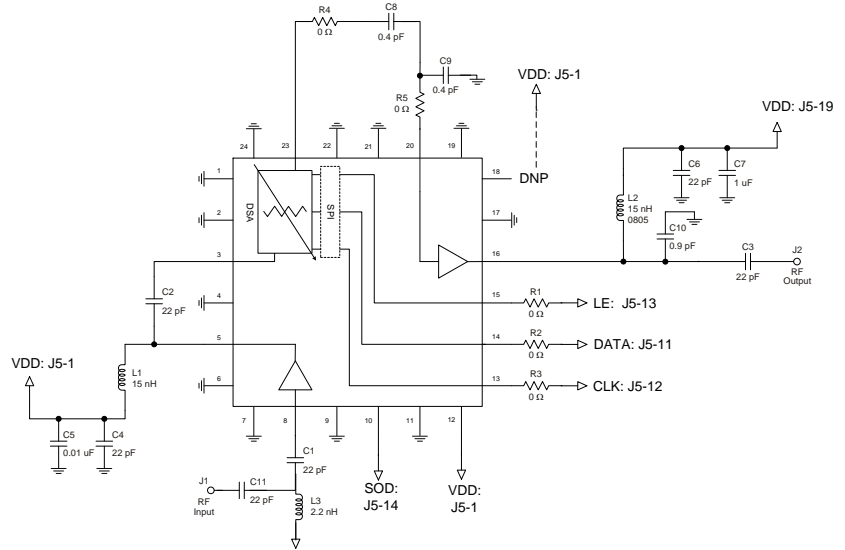
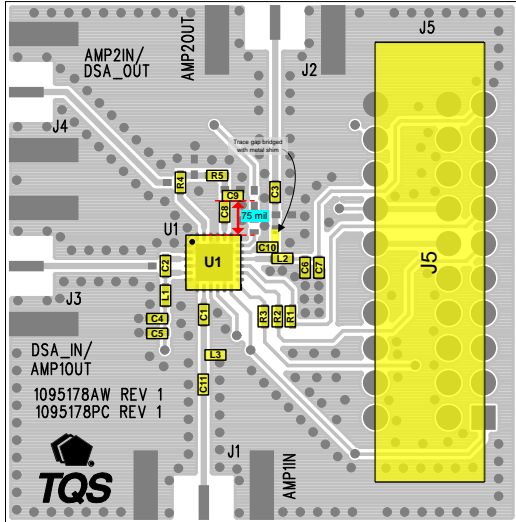

Notes:

1. See Evaluation Board PCB Information section for PCB material and stack-up.
2. Components are 0402 unless specified otherwise
3. 0 Ohm resistors may be replaced with 50 Ohm traces in the target application layout.
4. Critical component placement:
 - a. Distance between U1 to L3 (right edge): 145 mils
 - b. Distance between U1 to C11 (right edge): 205 mils

Bill of Material 3400 – 3600 MHz Reference Design

Reference Des.	Value	Description	Manuf.	Part Number
N/A	N/A	Printed Circuit Board	Qorvo	1095178
U1	N/A	Variable Gain Amplifier	Qorvo	TQM879028
L1, L2	15 nH	Ind, 0402, 5%	various	
R1, R2, R3, R4, R5	0 Ω	RES, 0402, CHIP	various	
L3	2.2 nH	Ind, 0402, 5%, CHIP	various	
C10	0.9 pF	CAP, 0402, ± 0.1 pF, 50V, NPO, U-Series	AVX	04025U0R9BAT2A
C8, C9	0.4 pF	CAP, 0402, ± 0.1 pF, 50V, NPO, U-Series	AVX	04025U0R4BAT2A
C1, C2, C3, C4, C6, C11	22 pF	CAP, 0402, 5%, 50V, NPO/COG	various	
C5	0.01 uF	CAP, 0402, 10%, 16V, X7R	various	
C7	1 uF	CAP, 0402, 10%, 10V, X5R	various	
J5	n/a	Conn, Receptacle, 20POS., 100RT/A, Dual	Tyco	5-532956-3

Typical Performance 3400 – 3600 MHz Reference Design

Test conditions unless otherwise noted: $V_{DD}=+5\text{ V}$, $I_{DD}=230\text{ mA}$ (typ.), $\text{Temp}=+25^\circ\text{C}$, maximum gain state

Parameter	Conditions	Typical Value			Units
Frequency		3400	3500	3600	MHz
Gain		26.9	27.9	28.0	dB
Input Return Loss		16	19	17	dB
Output Return Loss		14	12	10	dB
Output P1dB		+26.3	+26.7	+26.6	dBm
Output IP3	$P_{out}= +11\text{ dBm/ tone}, \Delta f=1\text{ MHz}$	+42.5	+43	+44	dBm

Performance Plots 3400 – 3600 MHz Reference Design

Test conditions unless otherwise noted: $V_{DD}=+5\text{ V}$, $I_{DD}=230\text{ mA}$ (typ.), $\text{Temp}=+25^\circ\text{C}$, maximum gain state

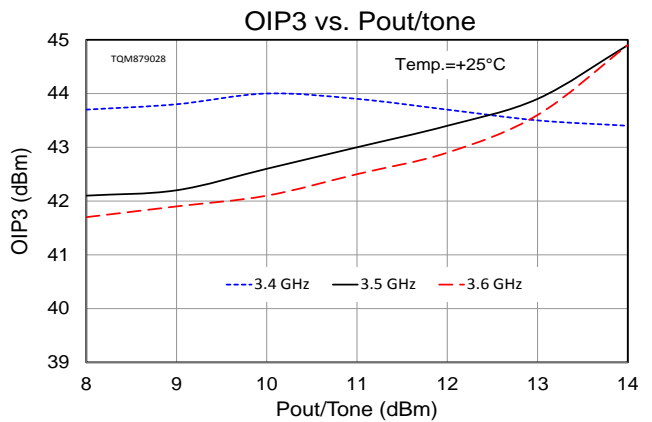
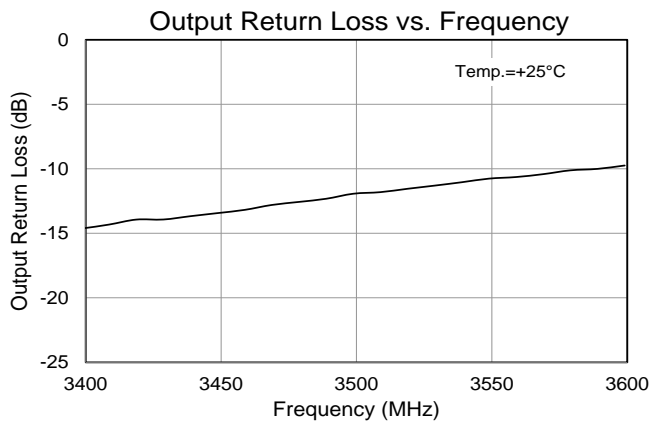
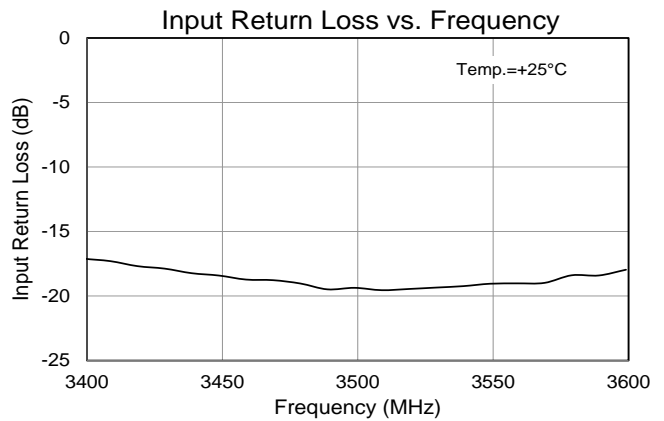
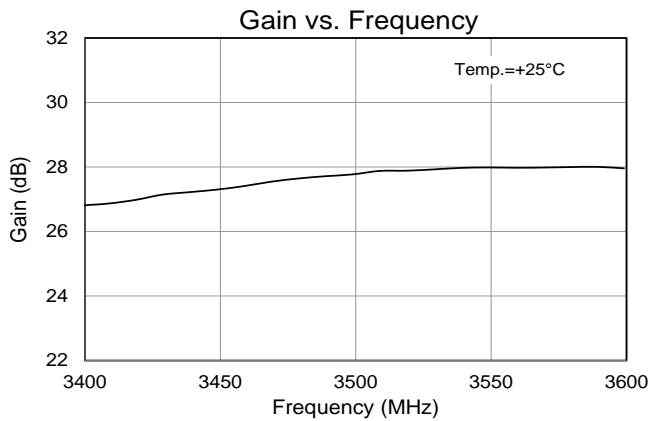

Detailed Device Description

The TQM879028 is a digital variable gain amplifier (DVGA) featuring high linearity over the entire gain control range. The amplifier module features the integration of a 50 Ω internally matched high linearity low noise amplifier gain block, a digital step attenuator (DSA), along with a high linearity ½W amplifier as shown in the functional diagram below. The DVGA has an operational frequency range from 0.7 – 4.0 GHz. The three stages are individually accessible via package I/O contacts. This permits full flexibility to insert other components or filters between the stages.

Functional Schematic Diagram

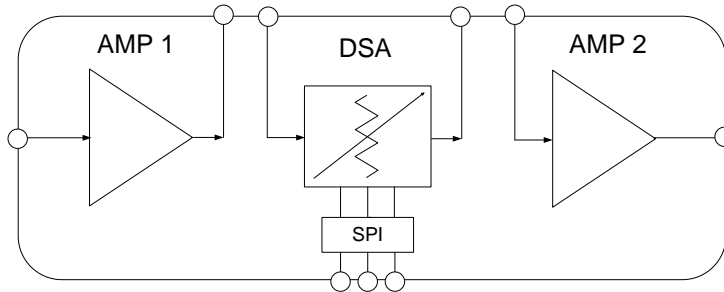

AMP1

AMP1 is a high linearity low noise amplifier. The amplifier has high gain across a broad range of frequencies while also providing very low noise. It is internally matched and only requires an external RF choke and blocking/bypass capacitors for operation from a single +5V supply. The internal active bias circuit also enables stable operation over bias and temperature variations. At 1.9 GHz, the amplifier typically provides 19.8 dB gain, +36 dBm OIP3, and 1.3 dB Noise Figure while only drawing 85 mA of current.

DSA (Digital Step Attenuator)

The DSA is a high linearity, low insertion loss, 6-bit, 31.5 dB Digital Step Attenuator (DSA) operating over the 700 - 4000 MHz frequency range. The digital step attenuator uses a single positive 5V supply and has a serial periphery interface (SPI™) for changing attenuation states. This product maintains high attenuation accuracy over frequency and temperature. No external matching components are needed for the DSA.

AMP2

AMP2 is a high-linearity driver amplifier that delivers high performance past 4GHz. With external tuning it can achieve over +44 dBm OIP3 with +27 dBm P1dB while only consuming 143 mA of quiescent current.

Chain Analysis Table

This table provides the typical performance of individual stages in the module as well as overall module performance.
 Frequency = 2140 MHz.

Parameter	AMP1	DSA	AMP2	Overall Module	Units
Gain	19.8	-1.6	14.4	32.6	dB
NF	1.5	1.6	3.9	1.6	dB
OIP3	+36	+55	+44	+44	dBm
P1dB	+20	+30	+27.6	+27.6	dBm
Icc	85	2	143	230	mA

Pin Configuration and Description

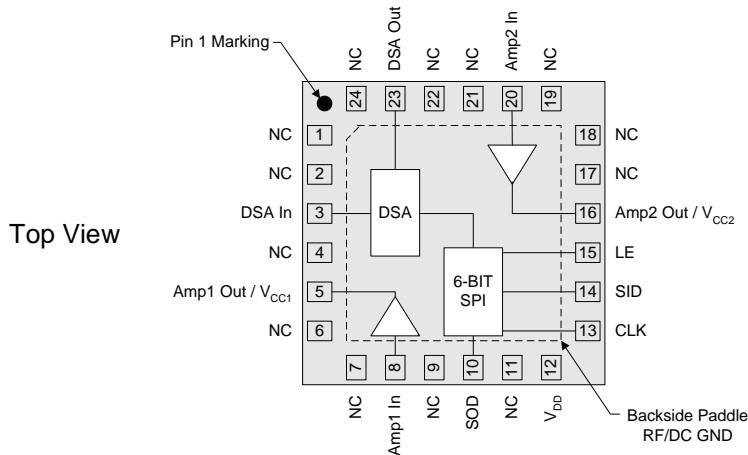

Pin No.	Label	Description
1, 2, 4, 6, 7, 9, 11, 17, 18, 19, 21, 22, 24	NC (No Connect)	No electrical connection. Land pads should be provided for PCB mounting integrity.
3	DSA In	DSA Input
5	Amp1 Out / V _{CC1}	RF output / DC supply (Amp1). Matched to 50 Ohms. Bias feed and DC blocking
8	Amp1 In	RF input (Amp1). Matched to 50 Ohms. DC blocking capacitor required.
10	SOD	Serial Output Data
12	V _{DD}	DC Supply
13	CLK	Serial Clock
14	SID	Serial Input Data
15	LE	Latch Enable
16	Amp2 Out / V _{CC2} Amp2	RF output / DC supply (Amp2). Band-specific matching circuit, bias feed and DC blocking capacitor required.
20	Amp2 In	RF input (Amp2). Band-specific matching circuit required.
23	DSA Out	DSA Output
Backside Paddle	RF/DC GND	RF/DC ground. Use recommended via pattern to minimize inductance and thermal resistance. See PCB Mounting Pattern for suggested footprint.

Evaluation Board PCB Information

Qorvo PCB 1095178 Material and Stack-up

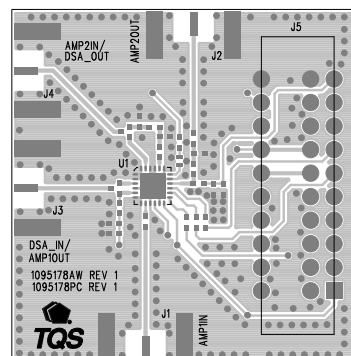
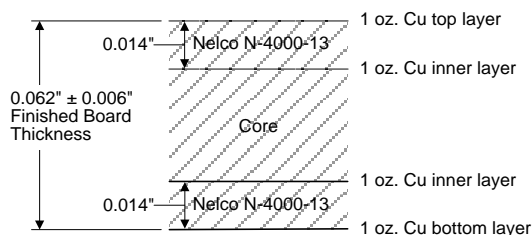

Mechanical Information

Package Marking and Dimensions

Marking: Part number – TQM879028
 Year/week/country code - YYWW CCCC
 Lot Code – AaXXXX

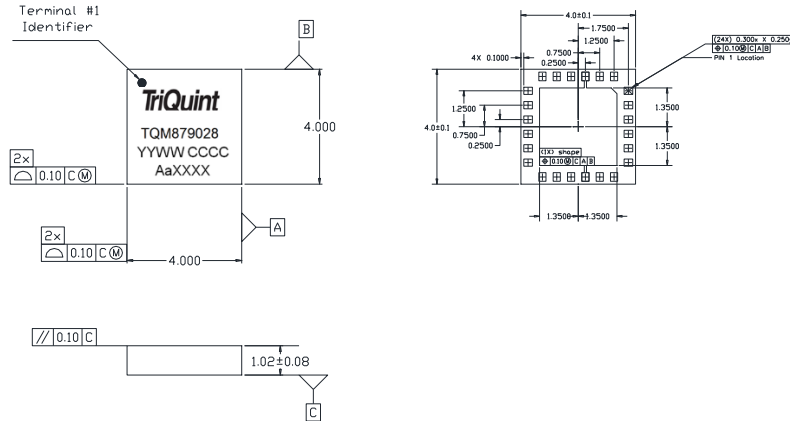

Notes:

1. All dimensions are in millimeters. Angles are in degrees.
2. Dimension and tolerance formats conform to ASME Y14.4M-1994.
3. The terminal #1 identifier and terminal numbering conform to JESD 95-1 SPP-012.

PCB Mounting Pattern

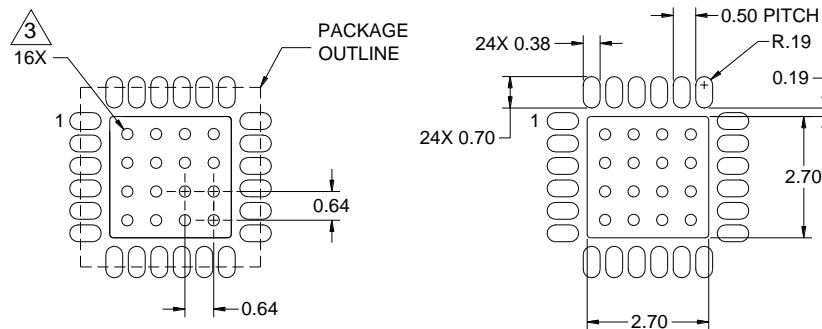

COMPONENT SIDE

Notes:

1. All dimensions are in millimeters. Angles are in degrees.
2. Use 1 oz. copper minimum for top and bottom layer metal.
3. Vias are required under the backside paddle of this device for proper RF/DC grounding and thermal dissipation.
4. Do not remove or minimize via hole structure in the PCB. Thermal and RF grounding is critical.
5. We recommend a 0.35mm (#80/.0135") dia. bit for drilling via holes and a final plated thru diameter of 0.25 mm (0.10").
6. Ensure good package backside paddle solder attach for reliable operation and best electrical performance.
7. There is no effect to the RF performance if Pads 9 and 22 are removed from the land pattern.

Handling Precautions

Parameter	Rating	Standard
ESD – Human Body Model (HBM)	Level 1A	ESDA / JEDEC JS-001-2012
ESD – Charged Device Model (CDM)	Level C3	JEDEC JESD22-C101F
MSL – Moisture Sensitivity Level	Level 3	IPC/JEDEC J-STD-020



Caution!
 ESD-Sensitive Device

Solderability

Compatible with both lead-free (260°C max. reflow temp.) and tin/lead (245°C max. reflow temp.) soldering processes. Solder profiles available upon request.

Contact plating: Electrolytic plated Au over Ni

RoHS Compliance

This part is compliant with EU 2002/95/EC RoHS directive (Restrictions on the Use of Certain Hazardous Substances in Electrical and Electronic Equipment). This product also has the following attributes:

- Product uses RoHS Exemption 7c-I to meet RoHS Compliance requirements
- Halogen Free (Chlorine, Bromine)
- Antimony Free
- TBBP-A (C₁₅H₁₂Br₄O₂) Free
- PFOS Free
- SVHC Free

Contact Information

For the latest specifications, additional product information, worldwide sales and distribution locations:

Web: www.qorvo.com

Tel: 1-844-890-8163

Email: customer.support@qorvo.com

For technical questions and application information:

Email: appsupport@qorvo.com

Important Notice

The information contained herein is believed to be reliable; however, Qorvo makes no warranties regarding the information contained herein and assumes no responsibility or liability whatsoever for the use of the information contained herein. All information contained herein is subject to change without notice. Customers should obtain and verify the latest relevant information before placing orders for Qorvo products. The information contained herein or any use of such information does not grant, explicitly or implicitly, to any party any patent rights, licenses, or any other intellectual property rights, whether with regard to such information itself or anything described by such information. **THIS INFORMATION DOES NOT CONSTITUTE A WARRANTY WITH RESPECT TO THE PRODUCTS DESCRIBED HEREIN, AND QORVO HEREBY DISCLAIMS ANY AND ALL WARRANTIES WITH RESPECT TO SUCH PRODUCTS WHETHER EXPRESS OR IMPLIED BY LAW, COURSE OF DEALING, COURSE OF PERFORMANCE, USAGE OF TRADE OR OTHERWISE, INCLUDING THE IMPLIED WARRANTIES OF MERCHANTABILITY AND FITNESS FOR A PARTICULAR PURPOSE.**

Without limiting the generality of the foregoing, Qorvo products are not warranted or authorized for use as critical components in medical, life-saving, or life-sustaining applications, or other applications where a failure would reasonably be expected to cause severe personal injury or death.

Copyright 2017 © Qorvo, Inc. | Qorvo is a registered trademark of Qorvo, Inc.