

1.View and size(视图及尺寸)

Main technical indicators(主要技术指标)	
1.Mating (插拔次数)	5000
2.Working Temperature (温度)	-55~+150 °C
3.IP Rating (防护级别)	IP 50
4.Diameter of socket end(插合端直径)	φ0.9
5.Testing Voltage (测试电压)	1500V
6.Working Voltage (工作电压)	1250V
7.Rated Current (额定电流)	10A
8.Shell material(壳体材质)	Brass (chromium-plated) shell and nut/(nickel-plated) lock sleeve and middleware/黄铜(镀铬)外壳和螺母(镀镍)锁套筒和中间件
9.Pin Material(插针材料)	Copper alloy gold plating(铜合金镀金)
10.Insulator material(绝缘体材质)	L:PPS P:PEEK

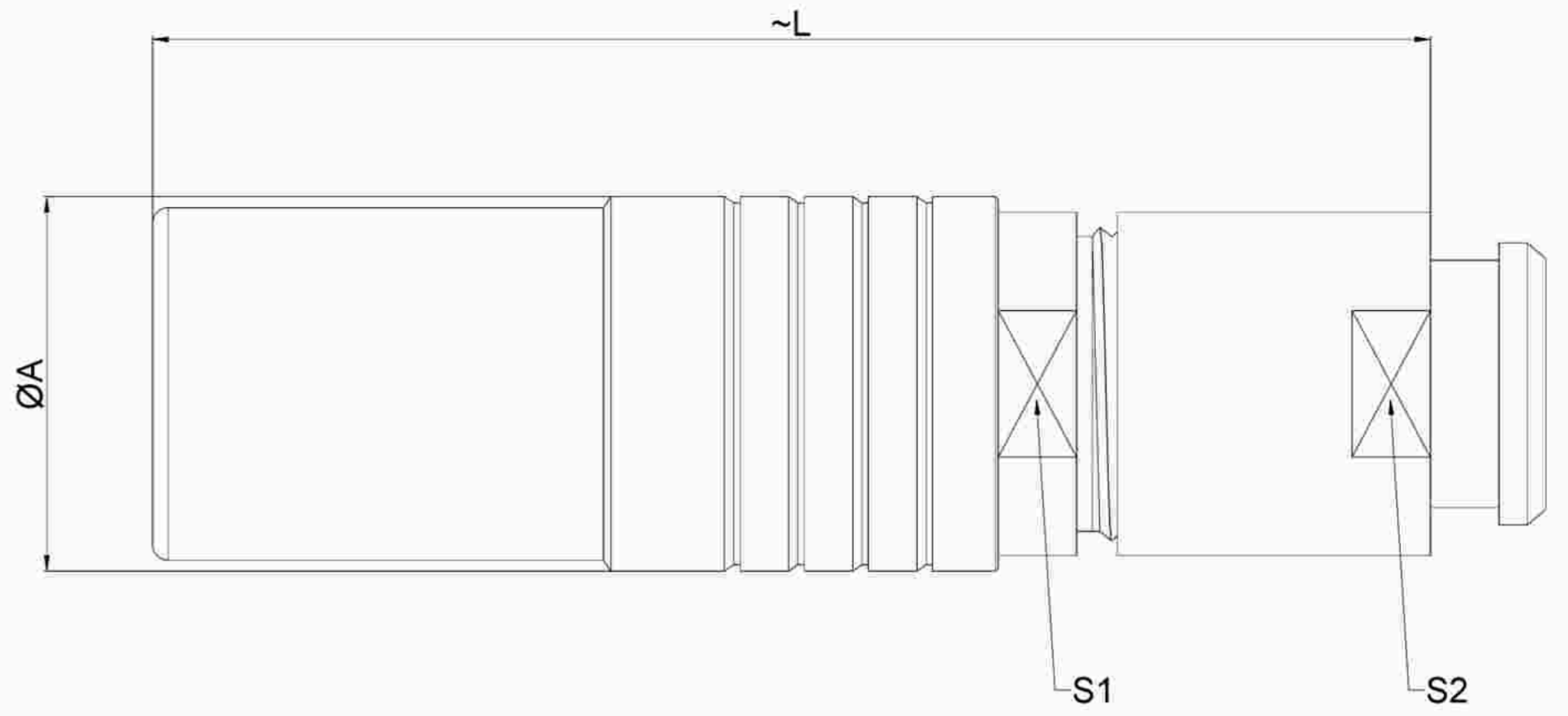

	φA	L	S1	S2
MM	φ16.5	46.0	13.0	12.0
in	0.6496	1.8110	0.5118	0.4725

Sum up(总结)

Series(系列)	B
Shell style/model (外壳样式/型号)	MHG: Floating socket, cable chuck and nut, used to install bending relief.(浮动式插座, 电缆夹头和螺母, 用来安装弯曲救济)
Button (按键)	A button(一个按键)
Termination type (终止类型)	Mother solder tin(母焊锡)
Line diameter awg(线材直径)	30-22AWG
Cable diameterφ (电缆直径)	φ4.3-5.2MM
Match plug(匹配插头)	TGG.2B.P08.CXAD52H

Location pin combination(定位销组合)

(编号) Number	Number of positioning pins(定位销数量)	Angle(角度)	Series(系列)--2B
G	One(1)		(Zero degrees)0°
A	Two(2)	A	Thirty degrees(30°)
B	Two(2)		Forty-five degrees(45°)
C	Two(2)		Sixty degrees(60°)
D	Two(2)	γ	95 degrees (95°)
E	Two(2)	β	120 degrees(120°)
F	Two(2)		145 degrees(145°)
J	Two(2)	A	37.5degrees(37.5°)
K	Two(2)		52.5degrees(52.5°)
L	Two(2)	γ	Seventy degrees(70°)

	A	B	C√	ANGLE	
5-10	±0.02	±0.05	±0.1	0°-30°	±0.1°
50-100	±0.1	±0.15	±0.2	61°-90°	±0.5°
50-100	±0.15	±0.2	±0.25		
100-	±0.15%	±0.20%	±0.25%		

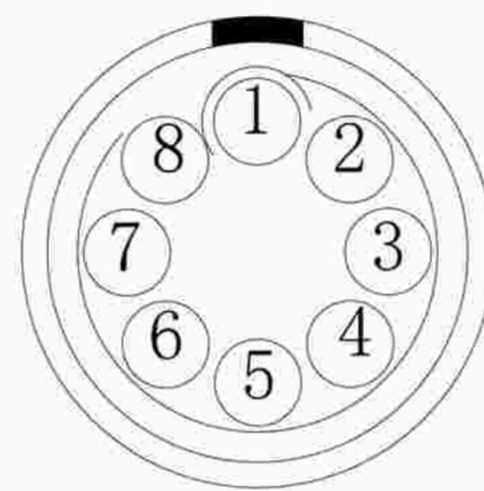

Welded surface (焊接面)

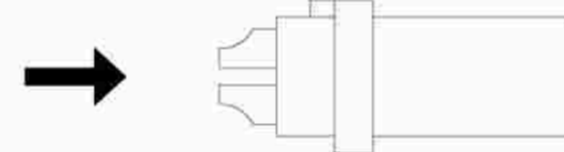

(Welded mother adhesive core) 焊接型母胶芯

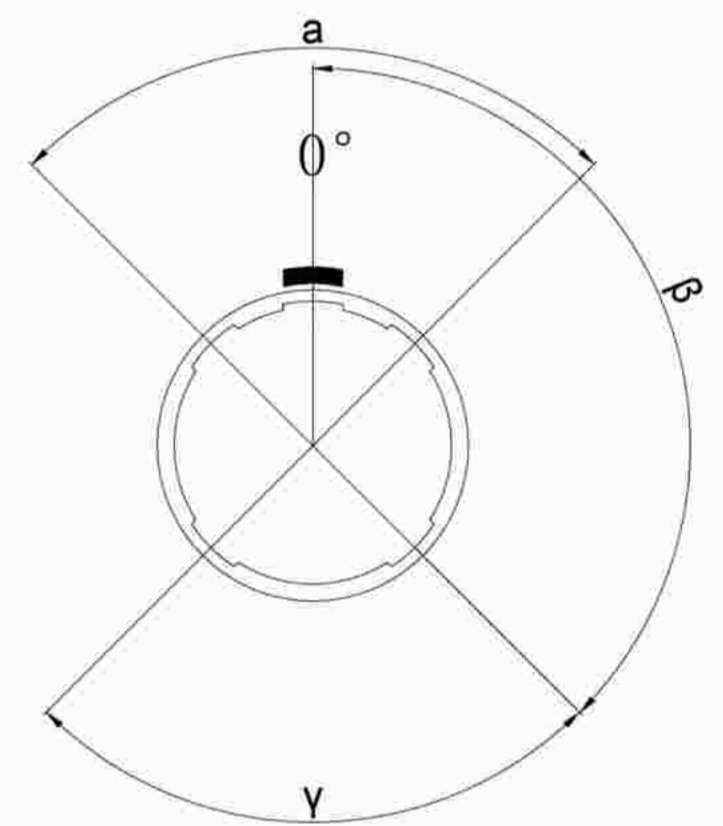

Positive view of the socket (插座正视图)

MH G. 2B. P08.C X L D 52 H

Model(型号)

Positioning pin(定位销)

Series(系列)

Needle core configuration(针芯配置)

Outer casing(外壳)

Insulator(绝缘体)

Needle core(针芯)

Type of CXamp(线夹类型)

Cable diameter(电缆直径)

SH means a sheath type, not a cover type.

(H表示护套型, 不表示为不带护套型)

DESIGNED(设计)
 广东星坤科技股份有限公司
 CHECKED(校对)
 APPROVED(审核)
 日期
 生效
 REVISIONS
 文件 工程 章
 www.helloxkb.com www.helloxkb.cn

DATE(日期)	SCALE(比额)	N/A(不适用)	MODEL TYPE
DATE(日期)	VIEW(视图)		型号类型: MHG.2B.P08.CXLD52H
DATE(日期)	UNIT(单位)	MM	PART NO. 2B8 core socket
MATERIAL (材料)			名称: 2B8芯插座
			DWG NO.:
			WEIGHT(重量)
			SHEET(表)
			REVISION(修订)
			1/1
			A0

KKB INDUSTRIAL PRECISION CO.,LIMITED