

HAR 3715, HAR 372x, HAR 373x

Robust Dual-Die Programmable
2D Position Sensor Family with
Arbitrary Output Function

Copyright, Warranty, and Limitation of Liability

The information and data contained in this document are believed to be accurate and reliable. The software and proprietary information contained therein may be protected by copyright, patent, trademark and/or other intellectual property rights of TDK-Micronas. All rights not expressly granted remain reserved by TDK-Micronas.

TDK-Micronas assumes no liability for errors and gives no warranty representation or guarantee regarding the suitability of its products for any particular purpose due to these specifications.

By this publication, TDK-Micronas does not assume responsibility for patent infringements or other rights of third parties which may result from its use. Commercial conditions, product availability and delivery are exclusively subject to the respective order confirmation.

Any information and data which may be provided in the document can and do vary in different applications, and actual performance may vary over time.

All operating parameters must be validated for each customer application by customers' technical experts. Any new issue of this document invalidates previous issues. TDK-Micronas reserves the right to review this document and to make changes to the document's content at any time without obligation to notify any person or entity of such revision or changes. For further advice please contact us directly.

Do not use our products in life-supporting systems, military, aviation and aerospace applications! Unless explicitly agreed to otherwise in writing between the parties, TDK-Micronas' products are not designed, intended or authorized for use as components in systems intended for surgical implants into the body, or other applications intended to support or sustain life, or for any other application in which the failure of the product could create a situation where personal injury or death could occur.

No part of this publication may be reproduced, photocopied, stored on a retrieval system or transmitted without the express written consent of TDK-Micronas.

TDK-Micronas Trademarks

- HAL
- 3D HAL

Third-Party Trademarks

All other brand and product names or company names may be trademarks of their respective companies.

Contents

Page	Section	Title
4	1.	Introduction
5	1.1.	Major Applications
6	1.2.	Features
7	2.	Ordering Information
7	2.1.	Device-Specific Ordering Code
9	3.	Functional Description
9	3.1.	General Function
10	3.2.	Signal Path and Register Definition
10	3.2.1.	Signal Path
10	3.2.2.	Register Definition
11	3.2.2.1.	RAM Registers
13	3.2.2.2.	EEPROM Registers
18	3.3.	Output Linearization
20	3.4.	NVRAM Register
21	3.5.	On-board Diagnostic Features
23	3.6.	SENT Output
25	4.	Specifications
25	4.1.	Outline Dimensions
26	4.2.	Soldering, Welding, Assembly
26	4.3.	Sensitive Areas
26	4.3.1.	Physical Dimension
26	4.3.2.	Definition of Magnetic Field Vectors
26	4.3.3.	Package Parameters and Position
27	4.4.	Pin Connections and Short Description
27	4.5.	Absolute Maximum Ratings
28	4.5.1.	Storage and Shelf Life
28	4.6.	Recommended Operating Conditions
30	4.7.	Characteristics
36	4.8.	Magnetic Characteristics
38	5.	Application Notes
38	5.1.	Ambient Temperature
38	5.2.	EMC and ESD
38	5.3.	Application Circuit for HAR 3715 and HAR 372x
39	5.4.	Application Circuit for HAR 373x
40	5.5.	Measurement of a PWM Output Signal of HAR 373x
40	5.6.	Recommended Pad Size SOIC8 Package
41	6.	Programming of the Sensor
41	6.1.	Programming Interface
42	6.2.	Programming Environment and Tools
43	6.3.	Programming Information
44	7.	Document History

Robust Dual-Die Programmable 2D Position Sensor Family with Arbitrary Output Function

Release Note: Revision bars indicate significant changes to the previous edition.

1. Introduction

The HAR 37xy is the full redundant (Dual-Die) version of the well known HAL 37xy family using the Micronas proprietary 3D HAL technology. It provides full redundancy due to two independent dies stacked in a single package each bonded on a separate side of the package. The stacked-die architecture ensures that both dies occupy the same magnetic field position, thus generating synchronous measurement outputs.

This new family has several members. HAR 372x provide linear, ratiometric analog output signals with integrated wire-break detection working with pull-up or pull-down resistors. Compared to the HAR 372x the HAR 3715 is splitting the 360° measurement range either into four repetitive 90° (MOD 90°) or three 120° (MOD 120°) segments. HAR 373x features digital output formats like PWM and SENT (according SAE-J2716 release 2010). The digital output format is customer programmable. The PWM outputs are configurable with frequencies between 0.2 kHz and 2 kHz with up to 12 bit resolution.

Conventional planar Hall technology is only sensitive to the magnetic field orthogonal to the chip surface. In addition to the orthogonal magnetic field, HAR 37xy is also sensitive to magnetic fields applied in parallel to the chip surface. This is possible by integrating vertical Hall plates into the standard CMOS process.

The sensor cell can measure three magnetic field components B_X , B_Y , and B_Z . This enables a new set of applications for position detection, like wide distance, angle or through-shaft angular measurements. The table below describes the different family members.

Type	Output Format	Detectable Field Component
HAR 3715	Analog/Modulo	B_X and B_Y
HAR 3725	Analog	B_X and B_Y
HAR 3726	Analog	B_Y and B_Z
HAR 3727	Analog	B_X and B_Z
HAR 3735	PWM & SENT	B_X and B_Y
HAR 3736	PWM & SENT	B_Y and B_Z
HAR 3737	PWM & SENT	B_X and B_Z

On-chip signal processing calculates the angle out of two of the magnetic field components and converts this value to an output signal. Due to the measurement method, the sensor exhibits excellent drift performance over the specified temperature range resulting in a new class of accuracy for angular or linear measurements.

Additionally to the built-in signal processing, the sensor features an arbitrary programmable characteristic for linearization of the output signal (with up to 33 setpoints).

Major characteristics like gain and temperature dependent offset of X/Y- and Z-channel, reference position, phase shift between X/Y- and Z-signal, hysteresis, low-pass filter frequency, output slope, and offset and clamping levels can be adjusted to the magnetic circuitry by programming the non-volatile memory.

The sensor contains advanced on-board diagnostic features that enhance fail-safe detection. In addition to standard checks, such as overvoltage and undervoltage detection and wire break, internal blocks such as ROM and signal path are monitored during normal operation. For devices with a selected PWM output, the error modes are indicated by a change of PWM frequency and duty-cycle. For SENT output a dedicated error code will be transmitted.

The devices are designed for automotive and industrial applications and operate with junction temperature from -40 °C up to 170 °C .

The sensors are available in a very small eight-pin SOIC8 package. The package outlines and the X-Y position of the sensitive areas are identical to the single-die version HAL 37xy.

1.1. Major Applications

Thanks to its redundancy capability, HAR 37xy can address safety-critical applications according to ISO26262 rules. Sensor's versatile programming characteristics and its high accuracy, make the HAR 37xy the optimal system solution for applications such as:

- Linear movement measurement,
 - Dual-Clutch transmission
 - Engine stroke sensor
 - Clutch pedal position
 - Cylinder and valve position sensing
- Rotary position measurement, like
 - Gear selector
 - Throttle valve position, etc.
 - Chassis position sensors (ride-height control) with HAR 3715
- Joystick
- Non-contact potentiometer

1.2. Features

Each die provides

- Angular and position measurement extremely robust against temperature and stress influence
- 12 bit ratiometric linear analog output for HAR 372x
- Modulo 90°/120° for HAR 3715
- 0.2 kHz to 2 kHz PWM (up to 12 bit) or 12 bit SENT output for HAR 373x
- Programmable arbitrary output characteristic with up to 33 setpoints
- 8 kHz sampling frequency
- Operates from 4.5 V up to 5.5 V supply voltage
- Operates from –40 °C up to 170 °C junction temperature
- Programming via the sensor's output pin
- Programmable characteristics in a non-volatile memory (EEPROM) with redundancy and lock function
- Programmable first-order low-pass filter
- Programmable hysteresis on X/Y or Z-channel
- Programmable output gain and offset
- X/Y- and Z-channel gain of signal path programmable
- Second-order temperature dependent offset of signal path programmable for X/Y- or Z-channel
- Phase shift between X/Y- and Z-channel programmable
- Programmable offset before angle calculation block
- Programmable output clamping for error band definition
- Programmable reference position
- Programmable magnetic detection range
- 32 bit identification number for customer
- 32 bit identification number with Micronas production information (like X,Y position on production wafer)
- On-board diagnostics of different functional blocks of the sensor
- Short-circuit protected push-pull output
- Over- and reverse voltage protection at V_{SUP}
- Under- and overvoltage detection of V_{SUP}
- Wire-break detection with pull-up or pull-down resistor
- EMC and ESD robust design

2. Ordering Information

A Micronas device is available in a variety of delivery forms. They are distinguished by a specific ordering code:

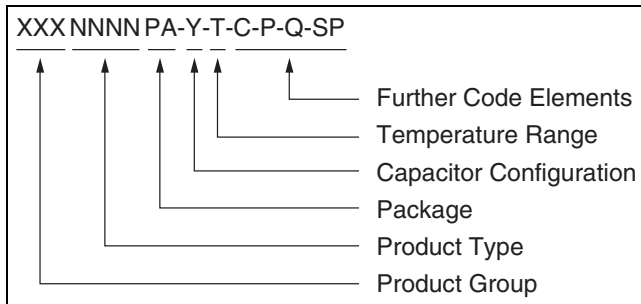

Fig. 2–1: Ordering Code Principle

For a detailed information, please refer to the brochure: “Hall Sensors: Ordering Codes, Packaging, Handling”.

2.1. Device-Specific Ordering Code

The HAR 37xy is available in the following package and temperature variant.

Table 2–1: Available package

Package Code (PA)	Package Type
DJ	SOIC8-1

Table 2–2: Available temperature ranges

Temperature Code (T)	Temperature Range
A	$T_J = -40\text{ °C to }+170\text{ °C}$

The relationship between ambient temperature (T_A) and junction temperature (T_J) is explained in Section 5.1. on page 38.

For available variants for Configuration (C), Packaging (P), Quantity (Q), and Special Procedure (SP) please contact TDK-Micronas.

Table 2–3: Available ordering codes and corresponding package marking

Available Ordering Codes	Package Marking
HAR3715DJ-A-[C-P-Q-SP]	3715A
HAR3725DJ-A-[C-P-Q-SP]	3725A
HAR3726DJ-A-[C-P-Q-SP]	3726A
HAR3727DJ-A-[C-P-Q-SP]	3727A
HAR3735DJ-A-[C-P-Q-SP]	3735A
HAR3736DJ-A-[C-P-Q-SP]	3736A
HAR3737DJ-A-[C-P-Q-SP]	3737A

3. Functional Description

3.1. General Function

HAR 3715, HAR 372x and HAR 373x are 2D position sensors based on TDK-Micronas' 3D HAL technology. They are dual-die integrated circuits with full redundant output signals. Each sensor die includes two vertical and one horizontal Hall plate with spinning current offset compensation for the detection of X, Y or Z magnetic field components, a signal processor for calculation and signal conditioning of two magnetic field components, protection devices, and a ratiometric linear analog, PWM or SENT output.

The spinning current offset compensation minimizes the errors due to supply voltage and temperature variations as well as external package stress.

The signal path of each die of HAR 37xy consist of two channels (CH1 and CH2). Depending on the product variant two out of the three magnetic field components are connected to Channel 1 and Channel 2.

The sensors can be used for angle measurements in a range between 0° and 360° (end of shaft and through shaft setup) as well as for robust position detection (linear movement or position). The in-system calibration can be utilized by the system designer to optimize performance for a specific system. The calibration information is stored in an on-chip EEPROM.

The HAR 37xy is programmable by modulation of the output voltage. No additional programming pin is needed.

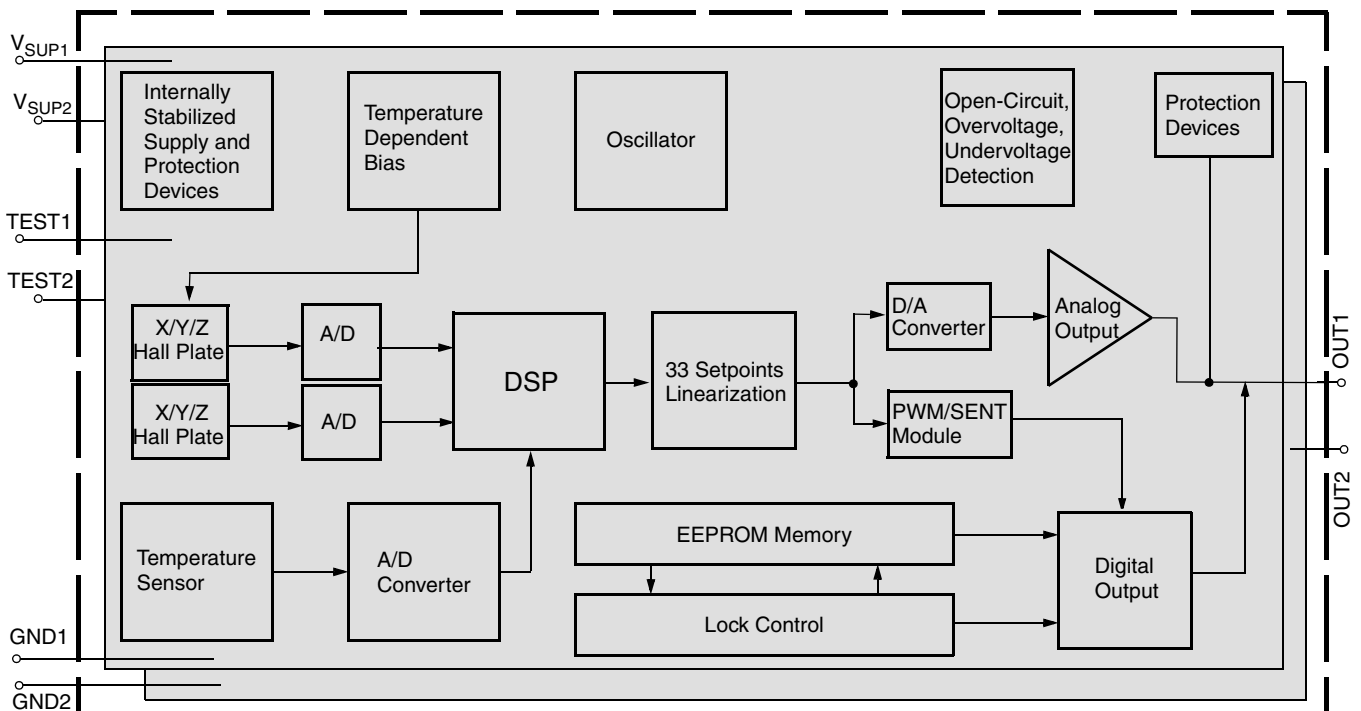

Fig. 3–1: HAR 37xy block diagram

3.2. Signal Path and Register Definition

3.2.1. Signal Path

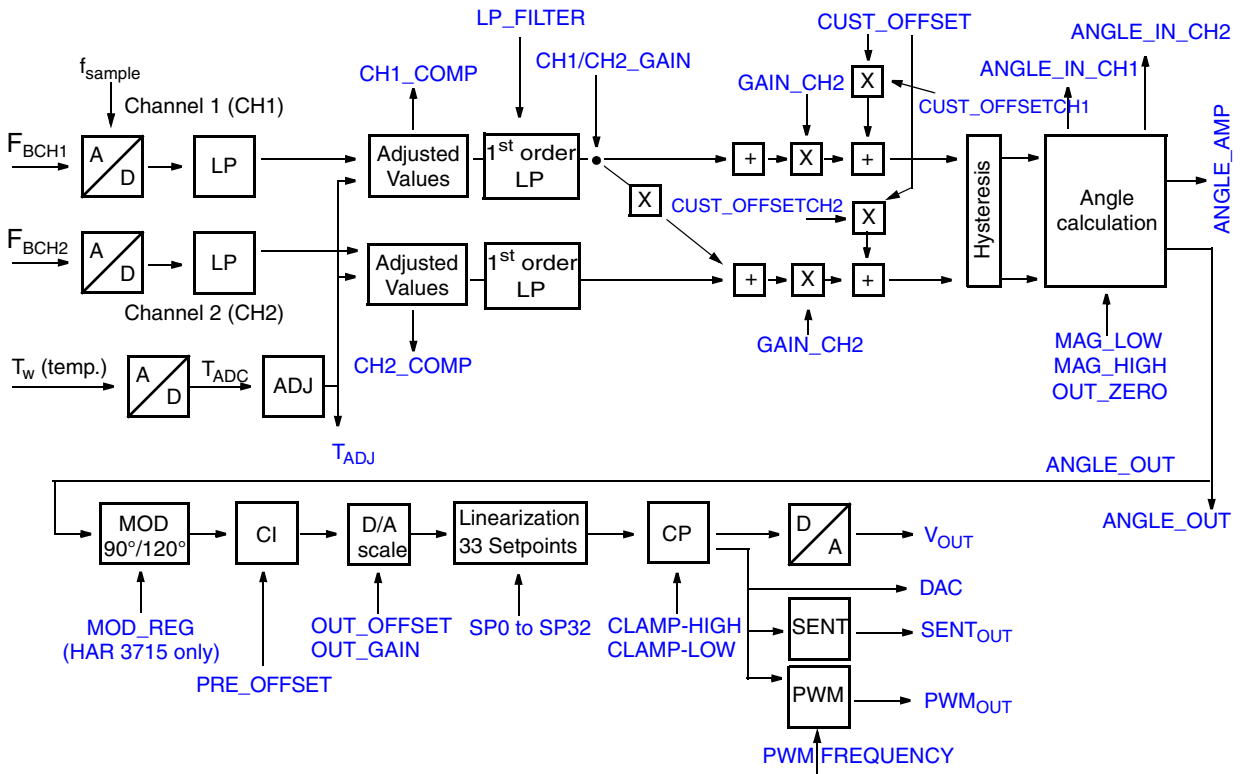

Fig. 3–2: Signal path of HAR 37xy (equal for both dies)

3.2.2. Register Definition

The DSP part of this sensor performs the signal conditioning. The parameters for the DSP are stored in the EEPROM/NVRAM register. Details of the signal path are shown in Fig. 3.2.

Terminology:

GAIN: name of the register or register value

Gain: name of the parameter

Blue color: register names

The sensor signal path contains two kinds of registers. Registers that are readout only (RAM) and programmable registers EEPROM/NVRAM. The RAM registers contain measurement data at certain steps of the signal path and the EEPROM/NVRAM registers have influence on the sensors signal processing.

3.2.2.1. RAM Registers

TADJ

The TADJ register contains the digital value of the sensor junction temperature. It has a length of 16 bit and is binary coded. From the 16 bit only the range between 0 and 32767 is used for the temperature information. Typically the temperature sensor is calibrated in the way that at -40°C the register value is 100 LSB and at 160°C it is 12000 LSB.

CH1_COMP and CH2_COMP

CH1_COMP and CH2_COMP register contain the temperature compensated magnetic field information of channel 1 and channel 2. Both registers have a length of 16 bit each and are two's-complement coded. Therefore, the register values can vary between -32768 and 32767 .

ANGLE_IN_CH1 and ANGLE_IN_CH2

ANGLE_IN_CH1 and ANGLE_IN_CH2 register contain the customer compensated magnetic field information of channel 1 and channel 2 used for the angle calculation. These registers include already customer phase-shift, gain and offset correction as well as an hysteresis. Both registers have a length of 16 bit each and are two's-complement coded. Therefore, the register values can vary between -32768 and 32767 .

ANGLE_OUT

The ANGLE_OUT register contains the digital value of the position calculated by the angle calculation algorithm. It has a length of 16 bit and is binary. From the 16 bit only the range between 0 and 32767 is used for the position information. Position can either be an angular position (angle) or a virtual angle calculated out of two magnetic field directions in case of linear position measurements.

DAC

The DAC register contains the digital equivalent of the output voltage, PWM output duty-cycle or the SENT data. It has a length of 16 bit and is binary. From the 16 bit only the range between 0 and 32767 is used for the position information. Position can either be an angular position (angle) or a virtual angle calculated out of two magnetic field directions in case of linear position measurements.

ANGLE_AMP

The ANGLE_AMP register contains the digital value of the magnetic field amplitude calculated by the angle calculation algorithm. From mathematical point of view the amplitude can be calculated out of the signals in channel 1 and channel 2 (X-/Y-/Z-components).

Example:

$$\text{Amplitude} = \sqrt{\text{CH1}^2 + \text{CH2}^2}$$

The angle calculation algorithm adds a factor of roughly 1.6 to the equation for the magnetic amplitude. So the equation for the amplitude is defined as follows:

$$\text{ANGLE_AMP} \cong 1,6 \times \sqrt{\text{CH1}^2 + \text{CH2}^2}$$

DIAGNOSIS

The DIAGNOSIS register identifies certain failures detected by the sensor. HAR 37xy performs self-tests during power-up of the sensor and also during normal operation. The result of these self tests is stored in the DIAGNOSIS register. DIAGNOSIS register is a 16 bit register.

Bit no.	Function	Description
15:10	None	Reserved
9	DAC Output High Clamping	This bit is set to 1 in case that the high clamping value of the DAC is reached.
8	DAC Output Low Clamping	This bit is set to 1 in case that the low clamping value of the DAC is reached.
7	Channel 1 Clipping	These bits are set to 1 in case that the A/D converter in channel 1 and/or 2 detects an under- or overflow
6	Channel 2 Clipping	
5	DSP Self Test	The DSP is doing the internal signal processing like angle calculation, temperature compensation, etc. This bit is set to 1 in case that the DSP self test fails (continuously running)
4	EEPROM Self Test	This bit is set to 1 in case that the EEPROM self test fails. (Performed during power-up or continuously running)
3	ROM Check	This bit is set to 1 in case that ROM parity check fails. (continuously running)
2	None	Reserved
1	MAGHI	This bit is set to 1 in case that the magnetic field is exceeding the MAG-HI register value (magnetic field to high)
0	MAGLO	This bit is set to 1 in case that the magnetic field is below the MAG-LOW register value (magnetic field to low)

Details on the sensor self tests can be found in Section 3.5. on page 21.

PROG_DIAGNOSIS

The PROG_DIAGNOSIS register allows the customer to identify errors occurring during programming and writing of the EEPROM or NVRAM memory. The customer must check the first and second acknowledge. To enable debugging of the production line it is recommended to read back the PROG_DIAGNOSIS register in case of a missing second acknowledge. Please check the Programming Guide for HAR 37xy for further details.

The PROG_DIAGNOSIS register is a 16 bit register. The following table shows the different bits indicating certain error possibilities.

Bit no.	Function	Description
15:11	None	Reserved
10	Charge Pump Error	This bit is set to 1 in case that the internal programming voltage was too low
9	Voltage Error during Program/Erase	This bit is set to 1 in case that the internal supply voltage was too low during program or erase
8	NVRAM Error	This bit is set to 1 in case that the programming of the NVRAM failed
5:0	Programming	These bits are used for programming the memory

3.2.2.2. EEPROM Registers

Note For production and qualification tests it is mandatory to set the LOCK bit after final adjustment and programming.

Note Please refer to the “HAL 37xy, HAR 37xy User Manual” for further details on register settings/calculation and programming of the device.

Micronas ID's

The MIC_ID1 and MIC_ID2 registers are both 16 bit organized. They are read only and contain Micronas production information, like X/Y position on the wafer, wafer number, etc.

Customer ID's

The CUST_ID1 and CUST_ID2 registers are both 16 bit organized. These two registers can be used to store customer production information, like serial number, project information, etc.

CH1/CH2_GAIN

CH1/CH2_GAIN can be used to compensate a phase-shift between channel 1 and channel 2. The register has a length of 16 bit. It is possible to make a phase shift correction of $\pm 75^\circ$. The step size and therefore the smallest possible correction is 0.002° . The register is two's-complement coded and ranges from -32768 to 32767 . The register value is sin function based.

Neutral value for this register is zero (no Phase-shift correction).

Note In case the phase-shift correction is used, then it is necessary to adapt the settings of GAIN_CH2 too. For details see definition of GAIN_CH2.

GAIN_CH1 and GAIN_CH2

GAIN_CH1 and GAIN_CH2 can be used to compensate amplitude mismatches between channel 1 and channel 2. TDK-Micronas delivers pre calibrated sensors with compensated gain mismatch between channel 1 and channel 2. Nevertheless it is possible that due to the magnetic circuit a mismatch between channel 1 and channel 2 gain occurs. This can be compensated with GAIN_CH1 and GAIN_CH2.

Both registers have a length of 16 bit and are two's-complement coded. Therefore, they can have values between -32768 and 32767 (-2 to 2). For neutral settings both register values have to be set to 1 (register value 16384).

In case that the phase-shift correction is used it is necessary to change also the gain of channel 2 (see also CH1/CH2_GAIN). If phase-shift correction is used the corresponding register has to be set to

$$\text{GAIN_CH2} = \frac{16384}{\cos(\text{Phase-shift})}$$

Note In case GAIN_CH1 or GAIN_CH2 exceed the range of -2 to 2 (-32768 to 32767), then it is possible to reduce the gain of the opposite channel for compensation.

CUST_OFFSET

CUST_OFFSET can be used to compensate an offset in channel 1 and channel 2. TDK-Micronas delivers pre calibrated sensors. Nevertheless it is possible that due to the magnetic circuit an offset in channel 1 and channel 2 occurs. This can be compensated with CUST_OFFSET.

The customer offset can also have a temperature coefficient to follow the temperature coefficient of a magnet. The customer offset consists of a polynomial of second-order represented by the three registers CUST_OFFSET1...3.

The customer offset can be added to channel 1 and/or channel 2 by the selection coefficients CUST_OFFSETCH1 and CUST_OFFSETCH2. Additionally these two registers can be used to scale the temperature dependent offset between 0% and 100%

All five registers have a length of 16 bit and are two's-complement coded. Therefore, they can have values between -32768 and 32767 .

HYSTERESIS

HYSTERESIS defines the number of digital codes used as an hysteresis on channel 1 and channel 2 before the angle calculation. The purpose of this register is to avoid angle variation on the ANGLE_OUT register and finally on the output signal due to the noise on the ANGLE_IN_CH1 and ANGLE_IN_CH2 signals.

The register has a length of 16 bit and is two's complement number.

It is possible to program a hysteresis between 1 LSB and 16383 LSB. The register value itself must be stored as a negative value.

The hysteresis function is deactivated by setting the register value to zero.

OUT_ZERO

OUT_Zero defines the reference position for the angle output. It can be set to any value of the output range. It is the starting point/reference for the 33 setpoints. OUT_ZERO has a register length of 16 bit and it is two's-complement coded.

Note Before reading ANGLE_OUT it is necessary to set OUT_ZERO to 0.

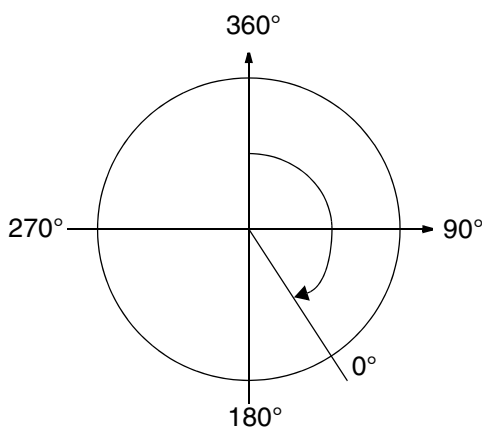

Fig. 3–3: Example definition of zero degree point

Secondly this angle can be used to shift the PI discontinuity point of the angle calculation to the maximum distance from the required angular range in order to avoid the 360°-wrapping of the output due to noise.

PRE_OFFSET

The PRE_OFFSET register allows to shift the angular range to avoid an overflow of the internal 16 bit calculation/signal path.

The PRE_OFFSET register has a length of 16 bit and is two's-complement coded.

OUT_GAIN

OUT_GAIN defines the gain of the output signal. The register has a length of 16 bit and is two's-complement coded. OUT_GAIN = 1 is neutral setting and leads to a change of the output signal from 0% to 100% for an angle change from 0° to 360° (if OUT_OFFSET is set to 0).

OUT_GAIN can be changed between -64 and 64.

OUT_OFFSET

OUT_OFFSET defines the offset of the output signal. The register has a length of 16 bit and is two's complement coded. OUT_OFFSET = 0 is neutral setting and leads to a change of the output signal from 0% to 200% of full scale for an angle change from 0° to 360° (If OUT_GAIN is set to 1).

OUT_Offset can be changed between -200% and 200% of full scale. OUT_OFFSET = 0 leads to a voltage offset of 0% of full scale and OUT_OFFSET = 32768 leads to a offset of -200% of V_{SUP} .

Clamping Levels (CLAMP-LOW & CLAMP-HIGH)

The clamping levels CLAMP_LOW and CLAMP_HIGH define the maximum and minimum output voltage of the analog output. The clamping levels can be used to define the diagnosis band for the sensor output. Both registers have a bit length of 16 bit and are two's-complement coded. Both clamping levels can have values between 0% and 100% of full scale.

Magnetic Range Check

The magnetic range check uses the magnitude output and compares it with an upper and lower limit threshold defined by the registers MAG-LOW and MAG-HIGH. If either low or high limit is exceeded then the sensor will indicate it with an overflow on the sensors output (output high clamping).

MAG-LOW

MAG-LOW defines the low level for the magnetic field range check function. This register has a length of 16 bit and is two's complement number.

MAG-HIGH

MAG-HIGH defines the high level for the magnetic field range check function. This register has a length of 16 bit and is two's complement number.

Low-Pass Filter

With the LP_Filter register it is possible to select different -3dB frequencies for HAR 37xy. The Low-Pass Filter is a 1st-order digital filter and the register is 16 bit organized. Various typical filter frequencies between 4 kHz (no filter) and 10 Hz are available.

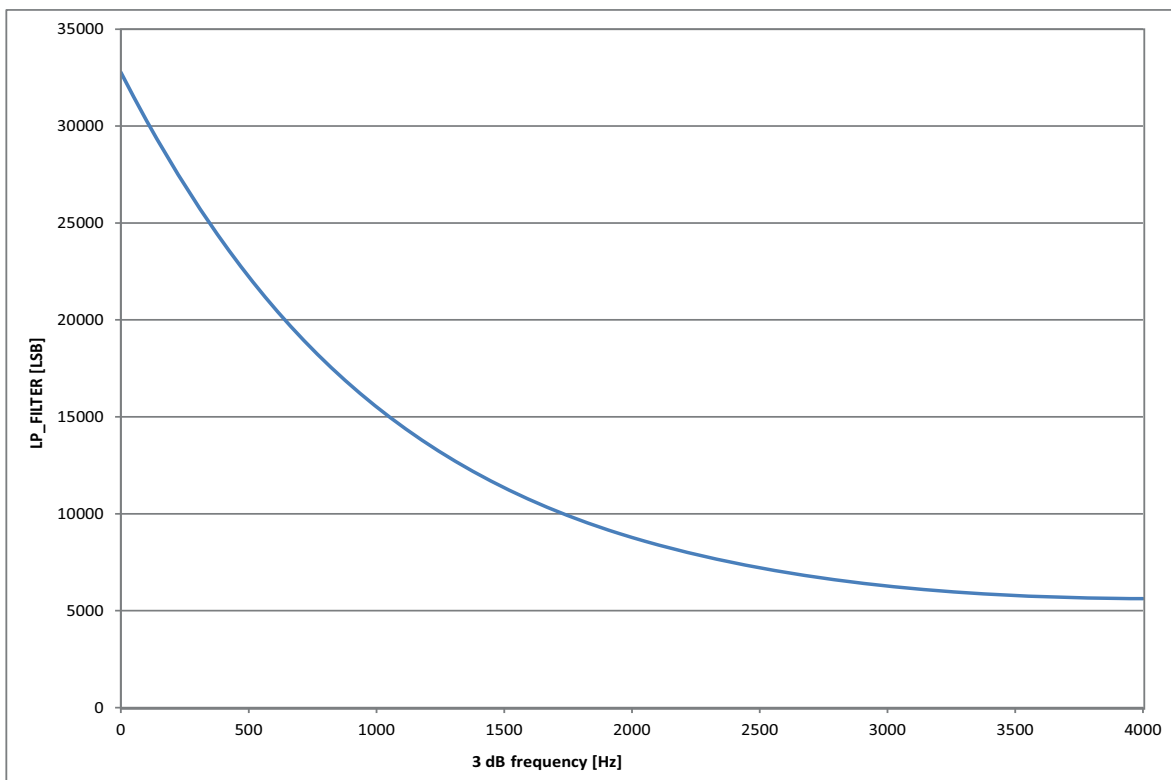

Fig. 3–4: 3dB filter frequency vs. LP_FILTER codes

Modulo Select

The MODULO_Select register is only available in HAR 3715. With this register, the customer can switch between Modulo 90° and 120° output.

HAR 3715 is splitting the 360° measurement range either into four repetitive 90° (MOD 90°) or three 120° (MOD 120°) segments.

3.3. Output Linearization

In certain applications (e.g. through shaft applications or position measurements) it is required to linearize the output characteristic. The resulting output characteristic “value vs. angle/position” is not a linear curve as in the ideal case. But it can be linearized by applying an inverse nonlinear compensation curve.

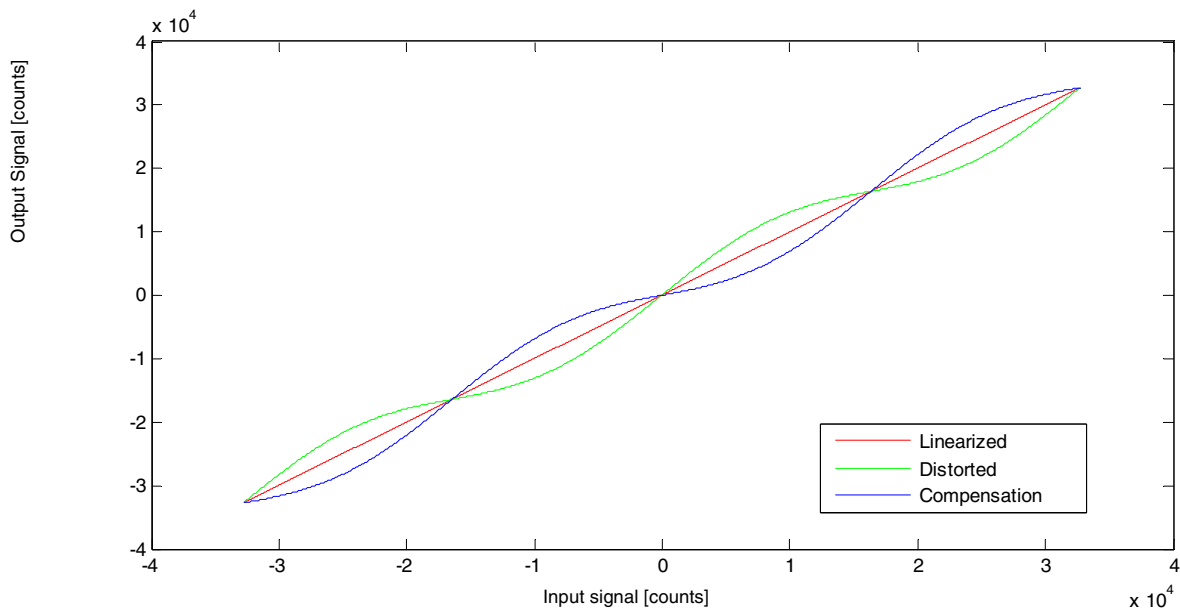

Fig. 3–5: Example for output linearization

For this purpose the compensation curve will be divided into 33 segments with equal distance. Each segment is defined by two setpoints, which are stored in EEPROM. Within the interval, the output is calculated by linear interpolation according to the position within the interval.

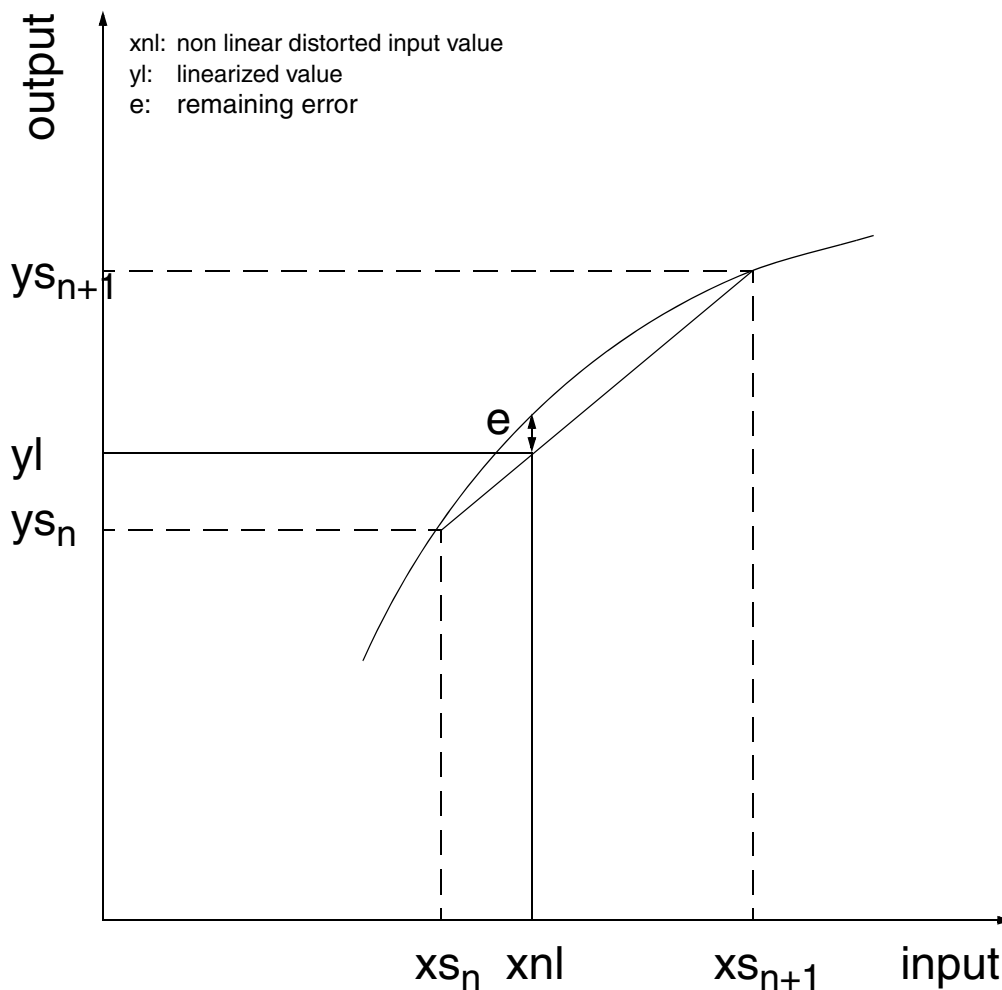

Fig. 3–6: Linearization - detail

The constraint of the linearization is that the input characteristic has to be a monotonic function. In addition, it is recommended that the input does not have a saddle point or inflection point, i.e. regions where the input is nearly constant. This would require a high density of set points.

To do a linearization the following steps are necessary:

- Measure output characteristics over full range
- Find the inverse (Point-wise mirroring the graph on the bisectrix)
- Do a spline fit on the inverse
- Insert digital value of set point position into spline fit function for each set point (0, 1024, 2048 ... 32768)
- Resulting values can be directly entered into the EEPROM

3.4. NVRAM Register

Customer Setup

The CUST_SETUP register is a 16 bit register that enables the customer to activate various functions of the sensor like diagnosis modes, functionality mode, customer lock, communication protocol speed, etc.

Table 3–1: Customer Setup Register

Bit no.	Function	Description
15	None	Reserved
14	EEPROM Self-Test	EEPROM Self-Test Mode (latched) 0: Running during Power-Up 1: Continuously
13	Communication speed	BiPhase-M protocol speed 0: typ. 1 ms 1: typ. 0.25 ms
12	DIGMOD	Output format for HAR 373x devices 0: PWM output 1: SENT output
11:10	PWMFREQ	Defines the frequency of the PWM output for HAR 373x devices only 0: 1 kHz 1: 500 Hz 2: 200 Hz 3: 2 kHz (11 bit)
9:8	Output Short Detection	0: Disabled 1: High & low side over current detect. Error Band = High: OUT = V _{SUP} Error Band = Low: OUT = GND 2: High & low side over current detect. Error Band = High: OUT = GND Error Band = Low: OUT = V _{SUP} 3: Low side over current detection OUT = Tristate in error case
7	Error Band	Error band selection for locked devices (Customer Lock bit set). 0: High error band (V _{SUP}) 1: Low error band (GND) The sensor will always go to high error band as long as it is not locked (Customer Lock bit not set).
6	Burn-In Mode	0: Disabled 1: Enabled
5	Functionality Mode	0: Extended 1: Normal (see Section 4.7. on page 30)
4	Communication Mode (POUT)	Communication via output pin 0: Disabled 1: Enabled
3	Overvoltage Detection	0: Overvoltage detection active 1: Overvoltage detection disabled

Table 3–1: Customer Setup Register, continued

Bit no.	Function	Description
2	Diagnosis Latch	Latching of diagnosis bits 0: No latching 1: Latched till next POR (power-on reset)
1	Diagnosis	0: Diagnosis errors force output to error band 1: Diagnosis errors do not force output to error band
0	Customer Lock	Bit must be set to 1 to lock the sensor memory

The Output Short Detection feature is implemented to detect a short circuit between two sensor outputs. The customer can define how the sensor should signalize a detected short circuit (see table above). The time interval in which the sensor is checking for an output short and the detectable short circuit current are defined in Section 4.7. on page 30.

This feature should only be used in case that two sensors are used in one module to detect a short between their outputs. In case that the Output Short Detection is not active both sensors will try to drive their output voltage and the resulting voltage will be within the valid signal band.

Note The Output Short Detection feature is only active after setting the Customer Lock bit and a power-on reset.

3.5. On-board Diagnostic Features

The HAR 37xy features two groups of diagnostic functions. The first group contains basic functions that are always active. The second group can be activated by the customer and contains supervision and self-tests related to the signal path and sensor memory.

Diagnostic features that are always active:

- Wire break detection for supply and ground line
- Undervoltage detection
- Thermal supervision of output stage (overcurrent, short circuit, etc.)
- EEPROM self-test at power-on

Diagnostic features that can be activated by customer:

- continuous EEPROM self-test
- ROM parity check
- Output signal clamping
- A/D converter clipping
- Continuous DSP self-test
- Magnetic range detection
- Overvoltage detection

In case of HAR 3715 and HAR 372x, the sensor indicates a fault immediately by switching the output signal to the selected error band in case that the diagnostic mode is activated by the customer. The customer can select if the output goes to the upper or lower error band by setting bit number 7 in the CUST_SETUP register (Table on page 20). An output short drives the output to VSUP, GND or tristate depending of the customer settings as described in Table 3–1 on page 20. Further details can be found in Section 4.7. on page 30.

Output short drives the output to VSUP or GND or tristate depending on the setting of bits 9:8 in the CUST_SETUP register.

The sensor switches the output to tristate if an over temperature is detected by the thermal supervision. The sensor switches the output to ground in case of a V_{SUP} wire break and to VSUP in case of a GND wire break.

HAR 373x indicates a failure by changing the PWM frequency. The different errors are then coded in different duty-cycles.

Table 3–2: Failure indication for HAR 373x

Failure Mode	Frequency	Duty-Cycle
EEPROM, ROM and DSP self-test	50%	95%
Magnetic field too low	50%	62.5%
Magnetic field too high	50%	55%
Overvoltage	50%	75%
Undervoltage	No PWM	n.a.
A/D converter clipping	50%	70%

In case of undervoltage, the PWM signal will be constantly 'high' or 'low' depending on the setting of bit number / in the CUST_SETUP register. Default setting is 'high' level.

Note In case of an error the sensor changes the selected PWM frequency.
Example: During normal operation the PWM frequency is 1 kHz, in case of an error 500 Hz.

3.6. SENT Output

The implementation of the SENT (Single Edge Nibble Transmission) interface of HAR 373x is according SAE J2716 release 2010-01.

Fig. 3–7 shows the general SENT protocol format. Every transmission starts with a low pulse. The signal is transmitted by the sensor as a series of pulses and data measured as falling to falling edge times.

The SENT telegram consists of a synchronization / calibration period, a status & communication nibble, three data nibbles, and a CRC nibble and a pause period. See Section 4.7. on page 30 for the timing parameters of a telegram.

All timing values in a SENT protocol are referenced to the clock tick time t_{tick} .

After reset the output is recessive high. The transmission starts with a low pulse of the synchronization phase (Fig. 3–7). Every low pulse has the same length specified by the parameter t_{nlow} . The synchronization period has always the same length of clock cycles. The clock variation is included in the parameter t_{sync} . The following status and data nibbles always start with a low pulse with t_{nlow} . The nibble high time of the status t_{stat} , the data $t_{\text{d3,2,1}}$ and the CRC t_{crc} depends on the transmitted value. Therefore, the message time of a SENT message depends on the tick time and the value which is transmitted by the message.

In order to synchronize the SENT messages to the measurement sampling rate an additional pause period is added, which is transmitted after the checksum nibble.

The time to transmit one message is calculated by:

$$t_{\text{message}} = t_{\text{sync}} + t_{\text{stat}} + t_{\text{d3}} + t_{\text{d2}} + t_{\text{d1}} + t_{\text{crc}}$$

The checksum nibble is a 4 bit CRC of the data nibbles only. The status & communication nibble is not included in the CRC calculation. The CRC is calculated using polynomial $x^4+x^3+x^2+1$ with seed value of 5. See SAE J2716 for further CRC implementation details.

As recommended by the SAE J2716 an additional zero nibble in addition to the 3 data nibbles for the CRC calculation has been implemented. This is a safety measure against common errors in the last data nibble and the checksum.

In HAR 373x the transmitted data nibbles are generated based on the DAC register value. Special data codes have been implemented for error indication via the SENT interface. The angular or linear position information is coded in the signal range from 2 to 4087 LSB in the 12 bit range. Table 3–3 gives an overview on the data nibble content.

HAR 373x is not using the status nibble for additional information transmission.

Table 3–3: Data Nibble Content SENT

12-bit value	Definition
4092 to 4095	Reserved
4091	Device Error: Device is failing in one of the self tests (EEPROM, ROM, DSP, Overvoltage)
4090	Signal Path Error: MAG-HIGH or -LOW are exceeded, adder overflow or clipping of channel 1 or 2
4089	Reserved
4088	Clamp-High: Upper signal range violation
2 to 4087	Angular or Position information
1	Clamp-Low: Lower signal range violation
0	During Initialization - Power Up

The SENT protocol starts after the initialization time of the sensor to ensure valid data after power-up.

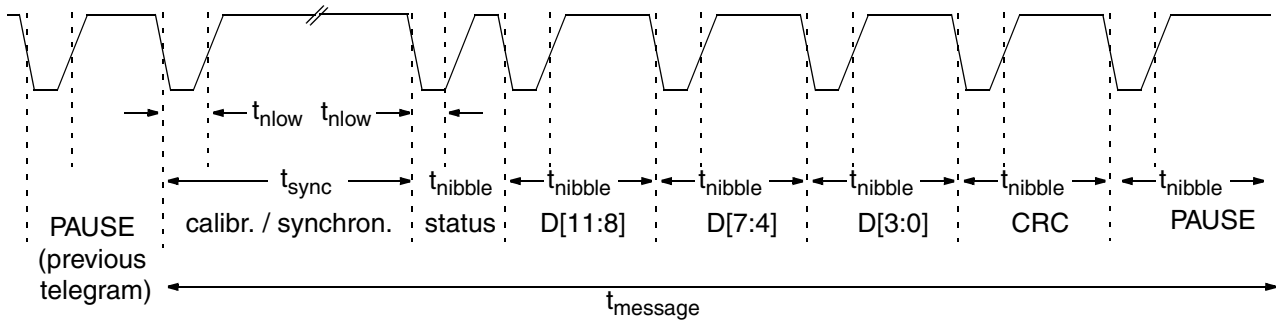

Fig. 3–7: SENT protocol format with 3 data nibbles and pause period

4. Specifications

4.1. Outline Dimensions

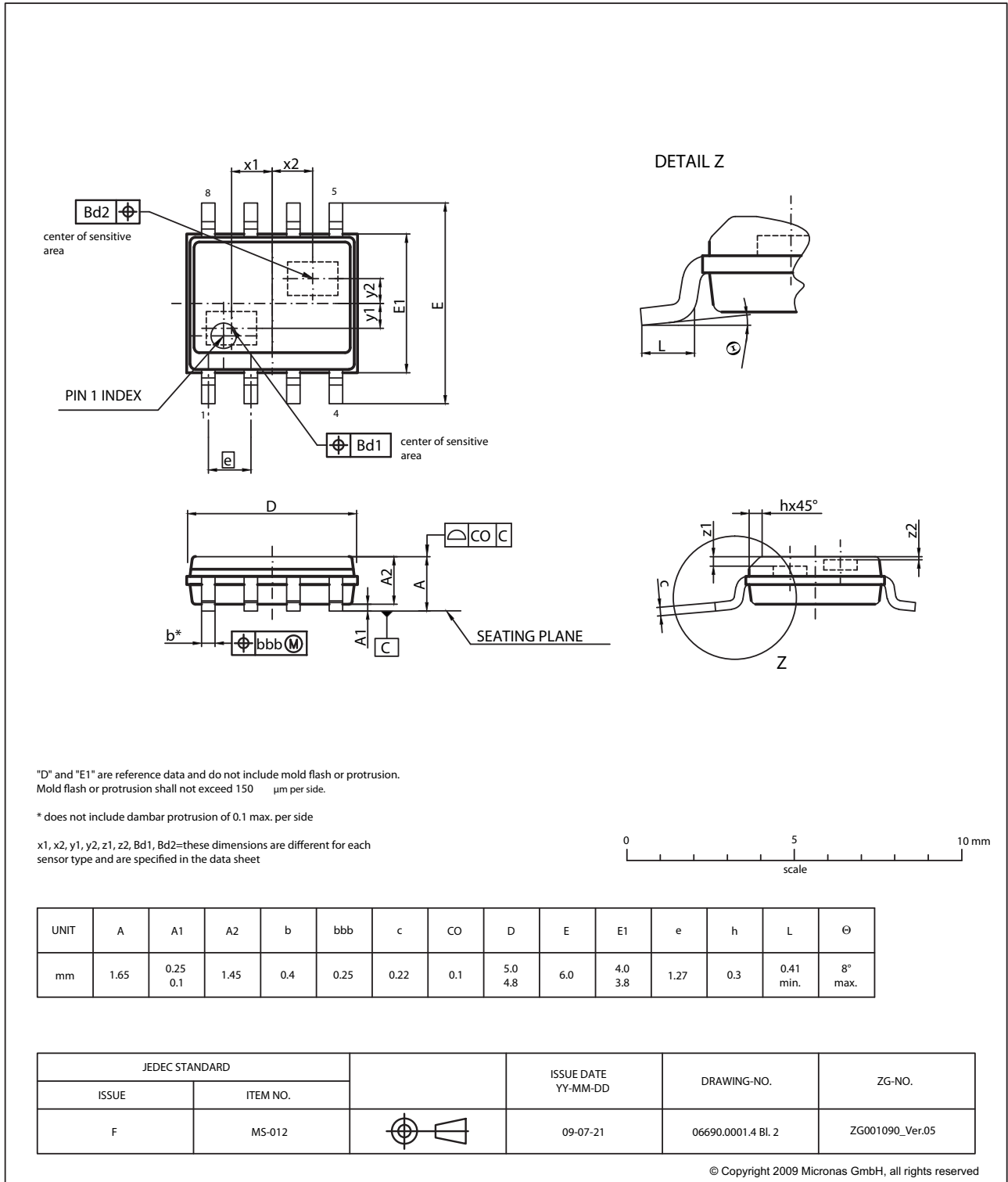

Fig. 4-1:
SOIC8-1: Plastic Small Outline IC package, 8 leads, gullwing bent, 150 mil
 Ordering code: DJ
 Weight approximately 0.076 g

4.2. Soldering, Welding, Assembly

Information related to solderability, welding, assembly, and second-level packaging is included in the document “Guidelines for the Assembly of Micronas Packages”.

It is available on the TDK-Micronas website (<http://www.micronas.com/en/service-center/downloads>) or on the service portal (<http://service.micronas.com>).

4.3. Sensitive Areas

4.3.1. Physical Dimension

275 μm x 275 μm

4.3.2. Definition of Magnetic Field Vectors

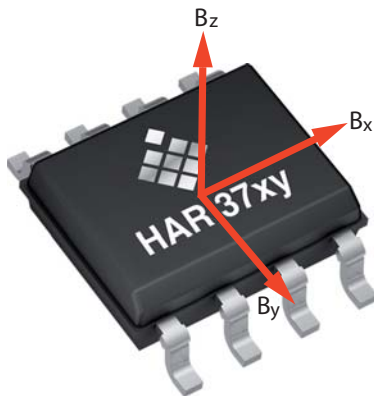

4.3.3. Package Parameters and Position

	SOIC8-1
Bd1 = Bd2	0.3 mm
x1 = x2	0 mm nominal (center of package)
y1 = y2	0 mm nominal (center of package)
z1	0.65 mm nominal
z2	0.24 mm nominal

4.4. Pin Connections and Short Description

Pin No.	Pin Name	Type	Short Description
Die 1			
1	VSUP1	SUPPLY	Supply Voltage Pin1
2	GND1	GND	Ground 1
3	TEST1	IN	Test 1
4	OUT1	I/O	Push-Pull Output and Programming Pin 1
Die 2			
5	VSUP2	SUPPLY	Supply Voltage Pin 2
6	GND2	GND	Ground 2
7	TEST2	IN	Test 2
8	OUT2	I/O	Push-Pull Output and Programming Pin 2

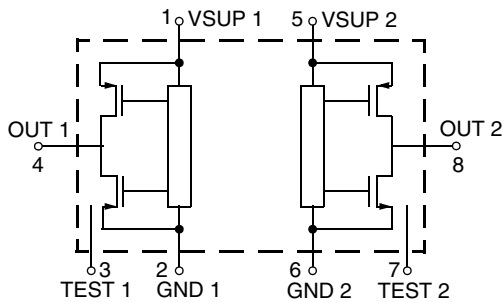

Fig. 4–2: Pin configuration

Note It is recommended to connect the TEST1 pin to GND1 and to connect the TEST2 pin to GND2

4.5. Absolute Maximum Ratings

Stresses beyond those listed in the “Absolute Maximum Ratings” may cause permanent damage to the device. This is a stress rating only. Functional operation of the device at these conditions is not implied. Exposure to absolute maximum rating conditions for extended periods will affect device reliability.

This device contains circuitry to protect the inputs and outputs against damage due to high static voltages or electric fields; however, it is advised that normal precautions be taken to avoid application of any voltage higher than absolute maximum-rated voltages to this high-impedance circuit.

All voltages listed are referenced to ground (GND).

Symbol	Parameter	Pin	Min.	Max.	Unit	Condition
V_{SUP}	Supply Voltage	VSUPx	-18	18	V	t < 1 hr
V_{OUT}	Output Voltage	OUTx	-6	18	V	t < 1 hr
$V_{OUT} - V_{SUP}$	Excess of Output Voltage over Supply Voltage	VSUPx, OUTx	-	2	V	
I_{OUT}	Continuous Output Current	OUTx	-10	10	mA	
T_J	Junction Temperature under Bias	-	-50	190	°C	1)
$T_{storage}$	Transportation/Short Term Storage Temperature	-	-50	150	°C	
B_{max}	Magnetic Field	-	unlimited	unlimited	T	
V_{ESD}	ESD Protection	VSUPx, OUTx, GNDx, TESTx	-2	2	kV	2) For all pin combinations (including die 1 to die 2)
		VSUP1, OUT1, GND1, TEST1	-4	4	kV	2) For all pin combinations (die 1 only)
		VSUP2, OUT2, GND2, TEST2	-4	4	kV	2) For all pin combinations (die 2 only)
1) For 96 h - Please contact TDK-Micronas for other temperature requirements 2) AEC-Q100-002 (100 pF and 1.5 kΩ)						

4.5.1. Storage and Shelf Life

Information related to storage conditions of Micronas sensors is included in the document "Guidelines for the Assembly of Micronas Packages". It gives recommendations linked to moisture sensitivity level and long-term storage.

It is available on the TDK-Micronas website (<http://www.micronas.com/en/service-center/downloads>) or on the service portal (<http://service.micronas.com>).

4.6. Recommended Operating Conditions

Functional operation of the device beyond those indicated in the "Recommended Operating Conditions/Characteristics" is not implied and may result in unpredictable behavior, reduce reliability and lifetime of the device.

All voltages listed are referenced to ground (GNDx).

Symbol	Parameter	Pin	Min.	Typ.	Max.	Unit	Condition
V _{SUP}	Supply Voltage of one die	VSUPx	4.5	5.0	5.5	V	Normal Operation During Programming
			5.7	6.0	6.5	V	
I _{OUT}	Continuous Output Current	OUTx	-1.2	-	1.2	mA	HAR 3715 and HAR 372x HAR 373x
				-	5.5	mA	
R _L	Load Resistor	OUTx	5	10	-	kΩ	HAR 3715 and HAR 372x pull-up & pull-down resistor
			1	-	-	kΩ	
C _L	Load Capacitance	OUTx	0.33	47	330	nF	HAR 3715 and HAR 372x HAR 373x
			-	-	1	nF	
N _{PRG}	Number of Memory Programming Cycles ¹⁾	-	-	-	100	cycles	0 °C < T _{amb} < 55 °C
B _{AMP}	Recommended Magnetic Field Amplitude	-	±20	-	±100	mT	
T _J	Junction Temperature ²⁾	-	-40	-	125	°C	for 8000 hrs ³⁾
			-40	-	150	°C	for 2000 hrs ³⁾
			-40	-	170	°C	for 1000 hrs ³⁾

¹⁾ The EEPROM is organized in three banks. Each bank contains up to 32 addresses. It is not allowed to program only one single address within one of the three banks. In case of programming one single address the complete bank has to be programmed.

²⁾ Depends on the temperature profile of the application. Please contact TDK-Micronas for life time calculations.

³⁾ Time values are not cumulative.

Note

It is also possible to operate the sensor with magnetic fields down to ±5 mT. For magnetic fields below ±20 mT the sensor performance will be reduced.

4.7. Characteristics

at $T_J = -40\text{ °C}$ to $+170\text{ °C}$, $V_{SUPx} = 4.5\text{ V}$ to 5.5 V , $GNDx = 0\text{ V}$, after programming and locking of the sensor, at Recommended Operation Conditions if not otherwise specified in the column “Conditions”.

Typical Characteristics for $T_J = 25\text{ °C}$ and $V_{SUPx} = 5\text{ V}$.

Symbol	Parameter	Pin	Limit Values			Unit	Test Conditions
			Min.	Typ.	Max.		
I_{SUP}	Supply Current over Temperature Range	VSUPx	–	8	13	mA	Current consumption of each die
	Resolution ¹⁾	OUTx	–	12	–	bit	for HAR 3715/HAR 372x ratio-metric to VSUPx for HAR 373x (depends on PWM Period)
			–	12	–	bit	
$t_{Startup}$	Start-up Time ²⁾	OUTx	–	–	1.7	ms	$C_L = 10\text{ nF}$ (see Fig. 4–3 on page 34)
Overvoltage and Undervoltage Detection							
$V_{SUP,UV}$	Undervoltage Detection Level	VSUPx	3.3 3.1	3.9 3.7	4.3 4.1	V V	Functionality Mode: Normal Functionality Mode: Extended CUST_SETUP register bit 5
$V_{SUP,UVhyst}$	Undervoltage Detection Level Hysteresis ²⁾	VSUPx	–	200	–	mV	
$V_{SUP,OV}$	Overvoltage Detection Level	VSUPx	5.6 8.5	6.2 9.5	6.9 10.4	V V	Functionality Mode: Normal Functionality Mode: Extended CUST_SETUP register bit 5
$V_{SUP,OVhyst}$	Overvoltage Detection Level Hysteresis ²⁾	VSUPx	–	225	–	mV	
Output Voltage in Case of Error Detection							
$V_{SUP,DIAG}$	Supply Voltage required to get defined Output Voltage Level ²⁾	VSUPx	–	2.3	–	V	Output behavior see Fig. 4–4 on page 34
$V_{Error,Low}$	Output Voltage Range of Lower Error Band ²⁾	OUTx	0	–	4	% V_{SUP}	$V_{SUP} > V_{SUP,DIAG}$ Analog Output $5\text{ k}\Omega \leq R_L \leq 200\text{ k}\Omega$
$V_{Error,High}$	Output Voltage Range of Upper Error Band ²⁾	OUTx	96	–	100	% V_{SUP}	$V_{SUP} > V_{SUP,DIAG}$ Analog Output $5\text{ k}\Omega \leq R_L \leq 200\text{ k}\Omega$
¹⁾ Guaranteed by Design ²⁾ Characterized on small sample size, not tested.							

Symbol	Parameter	Pin	Limit Values			Unit	Test Conditions
			Min.	Typ.	Max.		
Output Short Detection Parameter							
t_{OCD}	Over Current Detection Time ¹⁾	OUTx	–	128	–	μ s	
$t_{Timeout}$	Time Period without Over Current Detection ²⁾	OUTx	–	256	–	ms	
I_{OVC}	Detectable Output Short Current ¹⁾	OUTx	–	10	–	mA	
HAR 3715 and HAR 372x (Analog Output)							
t_{OSD}	Overall Signal Delay ¹⁾	OUTx	–	0.312	0.343	ms	Overall signal delay from magnetic field input to sensor output. Based on 8 kHz sample frequency
DNL	Differential Non-Linearity of D/A converter	OUTx	–3	0	3	LSB	
E_R	Ratiometric Error of Output over temperature (Error in V_{OUT}/V_{SUP})	OUTx	–0.2	0	0.2	%	Max of [$V_{OUT5} - V_{OUT4.5}$ and $V_{OUT5.5} - V_{OUT5}$] at $V_{OUT} = 10\%$ and $90\% V_{SUP}$
INL	Non-Linearity of D/A converter	OUTx	–0.1	0	0.1	%	% of supply voltage
ΔV_{OFFSET}	D/A converter offset drift over temperature range related to 25 °C ²⁾	OUTx	–0.2	0	0.2	% V_{SUP}	
V_{OUTH}	Output High Voltage ³⁾	OUTx	93	–	–	% V_{SUP}	R_L Pull-up/-down = 5 k Ω
V_{OUTL}	Output Low Voltage ³⁾	OUTx	–	–	7	% V_{SUP}	R_L Pull-up/-down = 5 k Ω
¹⁾ Guaranteed by Design ²⁾ Characterized on small sample size, not tested.							

Symbol	Parameter	Pin	Limit Values			Unit	Test Conditions
			Min.	Typ.	Max.		
ΔV_{OUTCL}	Accuracy of Output Voltage at Clamping Low Voltage over Temperature Range ²⁾	OUTx	-30	0	30	mV	R_L Pull-up/-down = 5 k Ω $V_{SUP} = 5V$
ΔV_{OUTCH}	Accuracy of Output Voltage at Clamping High Voltage over Temperature Range ²⁾	OUTx	-30	0	30	mV	
OUT_{Noise}	Output Noise RMS ²⁾⁵⁾	OUTx	-	1.5	3.7	mV	Output range 10% to 90%
R_{OUT}	Output Resistance over Recommended Operating Range	OUTx	-	1	10	Ω	$V_{OUTLmax} \leq V_{OUT} \leq V_{OUTHmin}$
Open-Circuit Detection							
V_{OUT}	Output voltage at open V_{SUPx} line	OUTx	0	0	0.15	V	$V_{SUP} = 5 V$ $R_L^{4)} = 10 k\Omega$ to 200 k Ω
			0	0	0.2	V	$V_{SUP} = 5 V$ $5 k\Omega \geq R_L^{4)} < 10 k\Omega$
V_{OUT}	Output voltage at open GNDx line	OUTx	4.85	4.9	5.0	V	$V_{SUP} = 5 V$ $R_L^{4)} = 10 k\Omega$ to 200 k Ω
			4.8	4.9	5.0	V	$V_{SUP} = 5 V$ $5 k\Omega \geq R_L^{4)} < 10 k\Omega$
HAR 373x (Digital Output)							
V_{OUTH}	Output High Voltage	OUTx	4.8	4.9	-	V	$V_{SUP} = 5 V$ $R_{Lpull-up/-down} = 5 k\Omega$
V_{OUTL}	Output Low Voltage	OUTx	-	0.1	0.2	V	$V_{SUP} = 5 V$ $R_{Lpull-up/-down} = 5 k\Omega$
			-	0.4	0.65	V	²⁾ $V_{SUP} = 5 V$ $R_{Lpull-up} = 1 k\Omega$
t_{rise}	Rise Time of Digital Output ²⁾	OUTx	-	0.2	0.4	μs	$V_{SUP} = 5 V$, R_L Pull-up = 1 k Ω $C_L = 1 nF$
²⁾ Characterized on small sample size, not tested. ³⁾ Signal band area with full accuracy is located between V_{OUTL} and V_{OUTH} . The sensors accuracy is reduced below V_{OUTL} and above V_{OUTH} ⁴⁾ RL can be pull-up or pull-down resistor ⁵⁾ 4 kHz digital low-pass filter (LP-Filter = off): +/- 20 mT min. magnetic field amplitude; $f_{BW} = 22.5$ kHz							

Symbol	Parameter	Pin	Limit Values			Unit	Test Conditions
			Min.	Typ.	Max.		
t_{fall}	Fall Time of Digital Output ²⁾	OUTx	–	0.25	0.4	μ s	$V_{SUP} = 5$ V, $R_{L\ Pull-up} = 1$ k Ω $C_L = 1$ nF
ROUT_DIG	On Resistance of Digital Pull-Up Driver	OUTx	–	100	200	Ω	
PWM Output							
$t_{startup}$	Start-up Time	OUTx	–	1.3	1.7	ms	
t_{OSD}	Overall Signal Delay ¹⁾	OUTx	–	0.312	0.343	ms	Overall signal delay from magnetic field input to sensor output. Transmission time of selected PWM frequency to be added. Based in 8 kHz sample frequency
OUT _{Noise}	Output Noise RMS ¹⁾²⁾	OUTx	–	0.03	0.074	%	Output range 100% DC
f_{PWM}	PWM Frequency	OUTx	1800 900 450 180	2000 1000 500 200	2200 1100 550 220	Hz	Customer programmable
J_{PWM}	RMS PWM Jitter ¹⁾	OUTx	–	1	2	LSB ₁₂	$f_{PWM} = 1$ kHz
SENT Output							
t_{tick}	Clock Tick Time	OUTx	–	2.75	–	μ s	
t_{nlow}	Nibble Low Time	OUTx	–	5	–	ttick	
t_{sync}	Calibration / Synchronization Period	OUTx	–	56	–	ttick	
t_{nibble}	Status & Communication Nibble, Data Nibbles and CRC Nibble Period	OUTx	12	–	27	ttick	$t_{nibble} = 12 + [\text{status data CRC}]$
$t_{message}$	Message Time	OUTx	116	–	176	ttick	
t_{pause}	Pause Period Time	OUTx	12	–	70	ttick	
¹⁾ Characterized on small sample size, not tested ²⁾ 4 kHz digital low-pass filter (LP-Filter = off): +/- 20 mT min. magnetic field amplitude; $f_{BW} = 22.5$ kHz							

Symbol	Parameter	Pin	Limit Values			Unit	Test Conditions
			Min.	Typ.	Max.		
SOIC8 Package							
R_{thja}	Thermal Resistance	—	—	—	116	K/W	Determined with a 1S1P board
R_{thjc}	Junction to Air	—	—	—	111	K/W	Determined with a 2S2P board
	Junction to Case	—	—	—	30	K/W	Determined with a 1S1P board
					30	K/W	Determined with a 2S2P board
R_{ISOL}	Isolation Resistance	—	4	—	—	M Ω	Between two dies

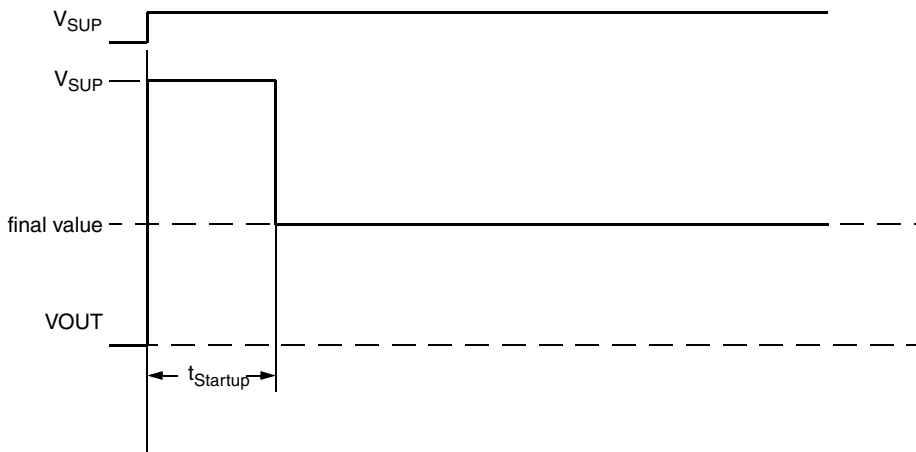

Fig. 4–3: POR timing

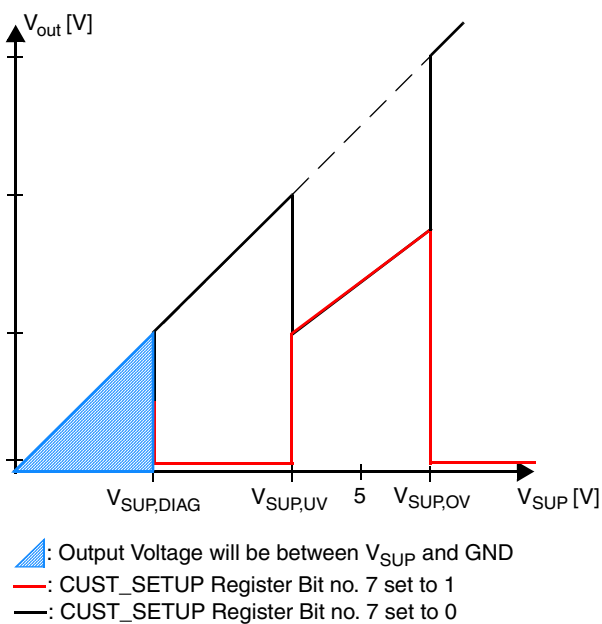

Fig. 4–4: Behavior of HAR 3715 and HAR 372x for different V_{SUP}

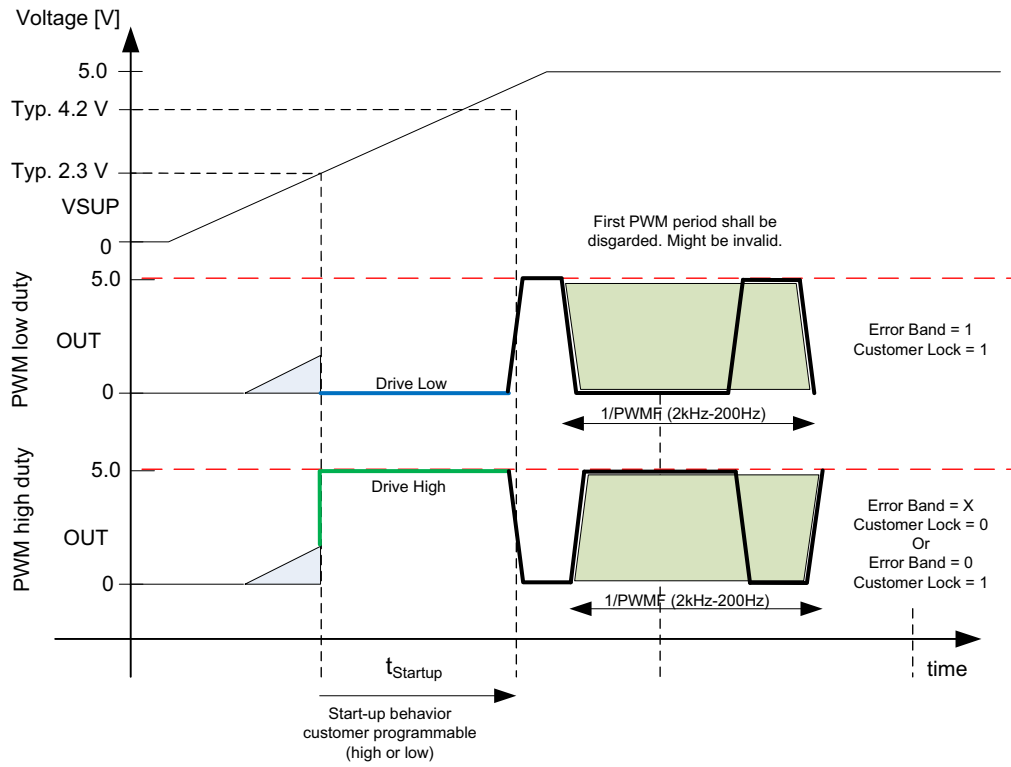

Fig. 4–5: Start-up behavior of HAR 373x with PWM output

4.8. Magnetic Characteristics

At $T_J = -40\text{ °C}$ to $+170\text{ °C}$, $V_{SUPx} = 4.5\text{ V}$ to 5.5 V , $GNDx = 0\text{ V}$, after programming and locking of the sensor, at Recommended Operation Conditions if not otherwise specified in the column “Conditions”.

Typical characteristics for $T_J = 25\text{ °C}$ and $V_{SUPx} = 5\text{ V}$.

Symbol	Parameter	Pin No.	Min.	Typ.	Max.	Unit	Test Conditions
Θ_{RANGE}	Detectable angle range	OUTx	0	–	360	°	
Θ_{res}	Angle resolution	OUTx	–	–	0.09	°	(360°/4096)
$E\Theta_{linxy}$	XY angle linearity error (on output of CORDIC)	OUTx	–0.5	–	0.5	°	Min. $B_{AMP} = \pm 30\text{ mT}$, $T_J = 25\text{ °C}^{1) 2)}$
$E\Theta_{linxy}$	X/Y angle linearity error over temperature (on output of CORDIC)	OUTx	–1.0	–	1.0	°	Min. $B_{AMP} = \pm 30\text{ mT}^{1) 2)}$ $T_J = -40 \dots 150\text{ °C}$ $T_J > 150 \dots 170\text{ °C}$
			–1.7	–	1.7	°	
			–1.5	–	1.5	°	Min. $B_{AMP} = \pm 20\text{ mT}^{1) 2)}$ $T_J = -40 \dots 150\text{ °C}$ $T_J > 150 \dots 170\text{ °C}$
			–2.4	–	2.4	°	
$ASMm_{X/Y_Z}$	Absolute sensitivity mismatch on raw signals between X/Y and Z channel	OUTx	–3	–	3	%	$T_J = 25\text{ °C}$
$Sense_{XYZ}$	Sensitivity of X/Y and Z Hall Plate	OUTx	118	128	138	LSB/ mT	$T_J = 25\text{ °C}$
SMm_{X/Y_Z}	Thermal sensitivity mismatch drift of calibrated signals between X/Y and Z channel	OUTx	–2.5	–	2.5	%	related to $25\text{ °C}^{1)}$ $T_J = -40 \dots 150\text{ °C}$ $T_J > 150 \dots 170\text{ °C}$
			–3.5	–	3.5	%	
SMm_{XY}	Thermal sensitivity mismatch drift of calibrated signals between X and Y channel	OUTx	–2.0	–	2.0	%	related to $25\text{ °C}^{1)}$ $T_J = -40 \dots 150\text{ °C}$ $T_J > 150 \dots 170\text{ °C}$
			–3.0	–	3.0	%	
$Offset_{XY}$	Offset of calibrated signals of X or Y channel	OUTx	–20	–	20	LSB ₁₅	$T_J = 25\text{ °C}^{1)}$ Can be compensated in customer application
$Offset_Z$	Offset of calibrated signal of Z channel	OUTx	–12	–	12	LSB ₁₅	$T_J = 25\text{ °C}^{1)}$ Can be compensated in customer application
$\Delta Offset_{XY}$	Offset drift of calibrated signals of X or Y channel	OUTx					over full temperature range related to $25\text{ °C}^{1)}$ $T_J = -40 \dots 150\text{ °C}$ $T_J > 150 \dots 170\text{ °C}$
			–50	–	50	LSB ₁₅	
			–100	–	100	LSB ₁₅	

1) Characterized on sample base, 3-sigma values, not tested for each device
2) Calculated angular error based on characterization and not on single error summation

Symbol	Parameter	Pin No.	Min.	Typ.	Max.	Unit	Test Conditions
ΔOffset_z	Offset drift of calibrated signals of Z channel	OUTx	-10	-	10	LSB ₁₅	over full temperature range related to 25 °C ¹⁾
$\Delta\text{SMm}_{XYZ\text{life}}$	Relative sensitivity mismatch drift of calibrated signals between X or Y channel and Z channel over life time	OUTx	-	1.0	-	%	after 1000h HTOL ¹⁾
$\Delta\text{Offset}_{XY\text{life}}$	Offset drift of calibrated signals of X or Y channel	OUTx	-	30	-	LSB ₁₅	after 1000h HTOL ¹⁾
$\Delta\text{Offset}_{Z\text{life}}$	Offset drift of calibrated signal of Z channel	OUTx	-	5	-	LSB ₁₅	after 1000h HTOL ¹⁾
¹⁾ Characterized on sample base, 3-sigma values, not tested for each device							

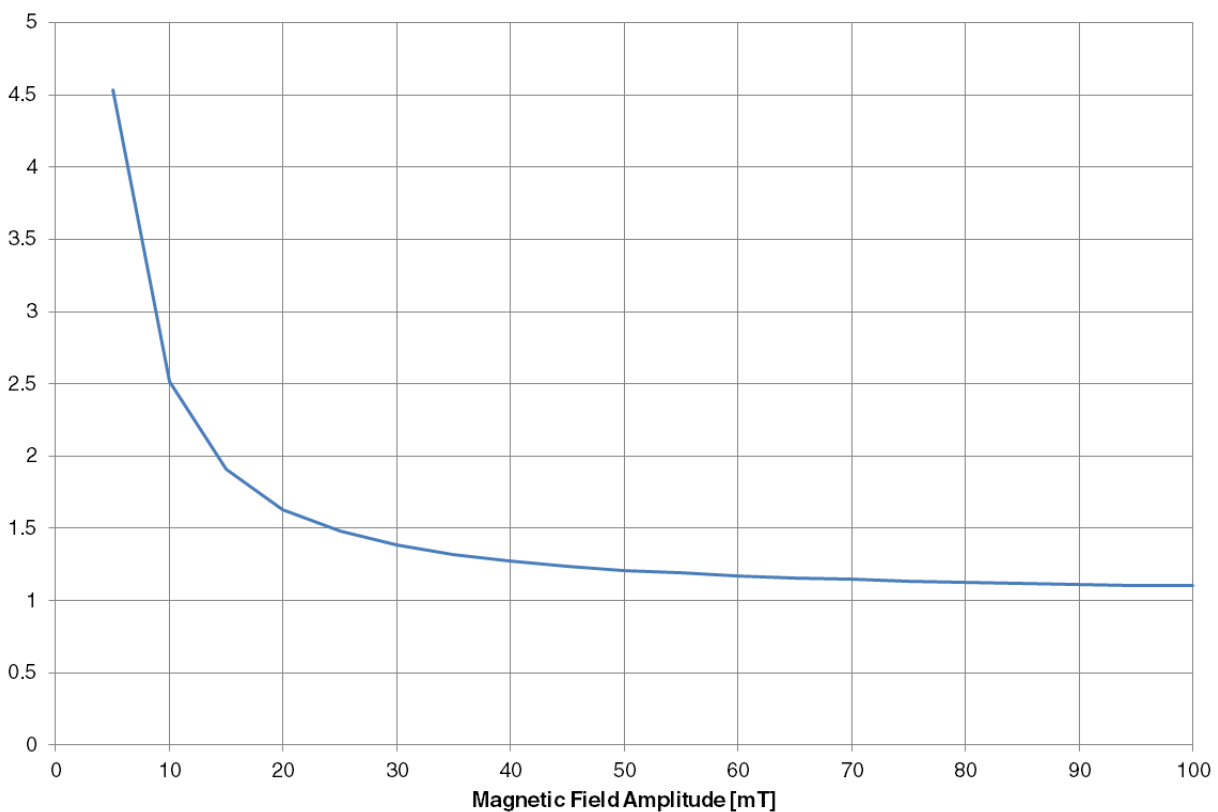

Fig. 4-6: Angular error versus magnetic field amplitude over full temperature range for devices using X and Y magnetic field component (for digital output)

5. Application Notes

5.1. Ambient Temperature

Due to the internal power dissipation, the temperature on the silicon chip (junction temperature T_J) is higher than the temperature outside the package (ambient temperature T_A).

$$T_J = T_A + \Delta T$$

The maximum ambient temperature is a function of power dissipation, maximum allowable die temperature and junction to ambient thermal resistance (R_{thja}). With a maximum of 5.5 V operating supply voltage the power dissipation P is 0.0825 Ω per die, for a total of 0.165 Ω . The junction to ambient thermal resistance R_{thja} is specified in Section 4.7. on page 30.

The difference between junction and ambient air temperature is expressed by the following equation:

$$\Delta T = P * R_{thja}$$

Note The calculated self-heating of the devices is only valid for the Rth test boards. Depending on the application setup the final results in an application environment might deviate from these values.

5.2. EMC and ESD

Please contact TDK-Micronas for detailed information on EMC and ESD results.

5.3. Application Circuit for HAR 3715 and HAR 372x

For EMC protection, it is recommended to connect one ceramic 47 nF capacitor each between ground and the supply voltage, respectively the output voltage pin.

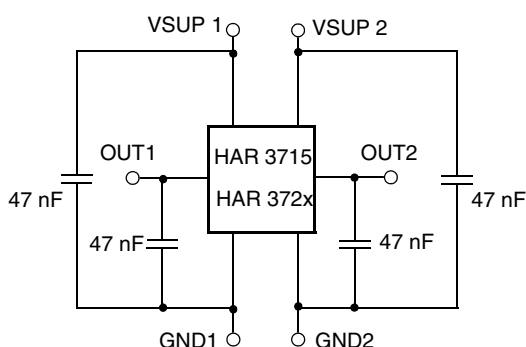

Fig. 5–1: Recommended application circuit for HAR 3715 and HAR 372x

If the two dies are operated in parallel to the same supply and ground line, they can be programmed individually as the communication with the sensors is done via their output pins.

Note It is recommended to connect TEST1 to GND1 and TEST2 to GND2.

5.4. Application Circuit for HAR 373x

PWM Output

In case of PWM output mode, it is recommended to connect one ceramic 47 nF capacitor between ground and the supply voltage and one ceramic 1 nF capacitor between the output pin and ground for EMC protection.

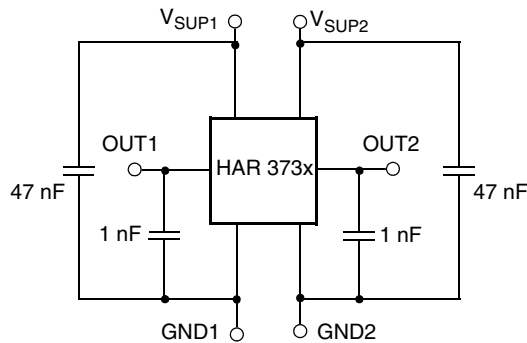

Fig. 5–2: Recommended application circuit for HAR 373x in PWM mode

SENT Output

In case of SENT output mode, it is recommended to connect one ceramic 47 nF capacitor between ground and the supply voltage and a filter structure at the output pin for EMC protection as well for having a SENT standard compliant output slew rate.

Following two setups have been tested:

- C01 = 180 pF, C02 = 2.2 nF, R01 = 120 Ω
- C01 = 180 pF, C02 = 3.3 nF, R01 = 180 Ω

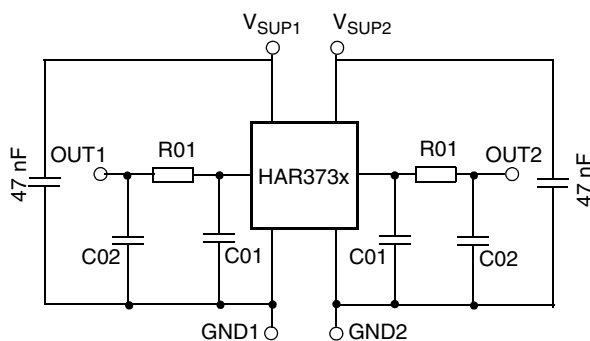

Fig. 5–3: Recommended application circuit for HAR 373x

If the two dies are operated in parallel to the same supply and ground line, they can be programmed individually as the communication with the sensors is done via their output pins.

Note It is recommended to connect TEST1 to GND1 and TEST2 to GND2.

5.5. Measurement of a PWM Output Signal of HAR 373x

In case of the PWM output, the magnetic field information is coded in the duty cycle of the PWM signal. The duty cycle is defined as the ratio between the high time “s” and the period “d” of the PWM signal (see Fig. 5–4).

Note The PWM signal is updated with the rising edge. Hence, for signal evaluation, the trigger-level must be the rising edge of the PWM signal.

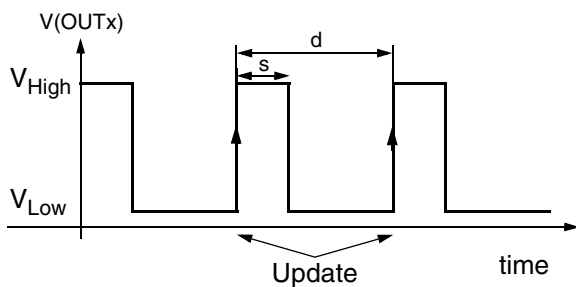

Fig. 5–4: Definition of PWM signal

5.6. Recommended Pad Size SOIC8 Package

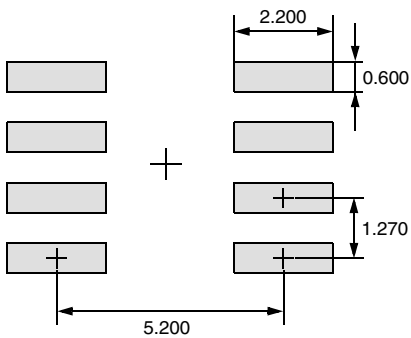

Fig. 5–5: Recommended Pad Size dimensions in mm

6. Programming of the Sensor

HAR 37xy features two different customer modes. In **Application Mode** the sensors provide a ratiometric analog output voltage or a digital output signal (PWM or SENT). In **Programming Mode** it is possible to change the register settings of the sensor.

After power-up the sensor is always operating in the **Application Mode**. It is switched to the **Programming Mode** by a pulse at the sensor output pin.

6.1. Programming Interface

In Programming Mode HAR 37xy is addressed by modulating a serial telegram on the sensors output pin. Both sensors answer with a modulation of the output voltage.

A logical “0” is coded as no level change within the bit time. A logical “1” is coded as a level change of typically 50% of the bit time. After each bit, a level change occurs (see Fig. 6–1).

The serial telegram is used to transmit the EEPROM content, error codes and digital values of the angle information from and to the sensor.

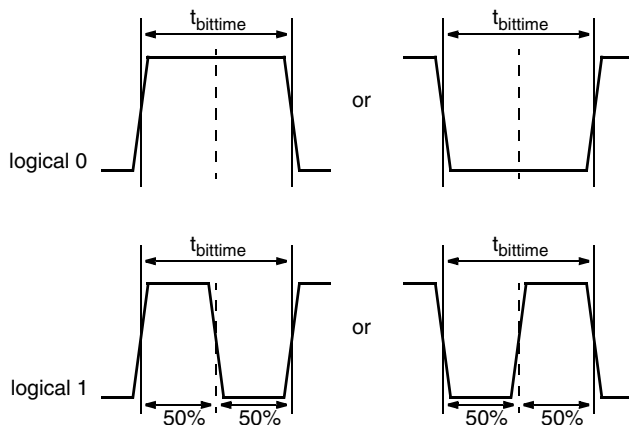

Fig. 6–1: Definition of logical 0 and 1 bit

A description of the communication protocol and the programming of the sensor is available in a separate document (HAL/HAR 37xy Programming Guide).

Table 6–1: Telegram parameters (All voltages are referenced to GNDx.)

Symbol	Parameter	Pin No.	Limit Values			Unit	Test Conditions
			Min.	Typ.	Max.		
V _{OUTL}	Voltage for Output Low Level during Programming through Sensor Output Pin	OUTx	0	–	0.2*V _{SUP}	V	for V _{SUP} = 5 V
			0		1	V	
V _{OUTH}	Voltage for Output High Level during Programming through Sensor Output Pin	OUTx	0.8*V _{SUP}	–	V _{SUP}	V	for V _{SUP} = 5 V
			4	–	5.0	V	
V _{SUPProgram}	V _{SUP} Voltage for EEPROM & NVRAM programming (during Programming)	VSUPx	5.7	6.0	6.5	V	Supply voltage for bidirectional communication via output pin as well as for 3-wire communication via supply voltage modulation
t _{bittime}	Biphase Bit Time	OUTx	900	1000	1100	μs	Cust. programmable, T _J = 25°C Bit 13 of Customer Setup = 0 Bit 13 of Customer Setup = 1
			225	250	275		
	Slew rate	OUTx	–	2	–	V/μs	

6.2. Programming Environment and Tools

For the programming of HAR 37xy during product development a programming tool including hardware and software is available on request. It is recommended to use the Micronas tool kit (USB-Kit and LabView Programming Environment) in order to facilitate the product development. The details of programming sequences are also available on request.

6.3. Programming Information

For production and qualification tests, it is mandatory to set the LOCK bit to one and the POUT bit to zero after final adjustment and programming of HAR 37xy.

Before locking the device, it is recommended to read back all register values to ensure that the intended data is correctly stored in the sensor's memory. Alternatively, it is also possible to cross-check the sensor output signal with the intended output behavior.

The success of the LOCK process shall be checked by reading the status of the LOCK bit after locking.

It is also mandatory to check the acknowledge (first and second) of the sensor after each write and store sequence to verify if the programming of the sensor was successful. To enable debugging of the production line, it is recommended to read back the PROG_DIAGNOSIS register in case of a missing second acknowledge. Please check HAL/HAR 37xy Programming Guide for further details.

Electrostatic Discharges (ESD) may disturb the programming pulses. Please take precautions against ESD.

Note Please check also the "HAL 37xy, HAR 37xy User Manual" and relevant documentation for the USB-Kit. It contains additional information and instructions about the programming of the devices.

7. Document History

1. "HAR 3715, HAR 372x, HAR 373x Robust Dual-Die Programmable 2D Position Sensor Family with Arbitrary Output Function", June 17, 2015, AI000180_001EN.
First release of the advance information.
2. "HAR 3715, HAR 372x, HAR 373x Robust Dual-Die Programmable 2D Position Sensor Family with Arbitrary Output Function", Jan. 18, 2016, DSH000175_001EN.
First release of the data sheet.

Major changes:

- Assembly and storage information changed
 - Absolute maximum ratings:
ESD protection voltages changed
 - Magnetic characteristics: values changed
3. "HAR 3715, HAR 372x, HAR 373x Robust Dual-Die Programmable 2D Position Sensor Family with Arbitrary Output Function", May 5, 2017, DSH000175_002EN.
Second release of the data sheet.

Major changes:

- Update of some electrical parameters
- Storage temperature added
- Graph with start-up behavior in PWM mode added