

Development Board EPC9147B Quick Start Guide

*Motor Drive Controller Interface Board –
Texas Instruments LAUNCHXL*

Revision 2.0



DESCRIPTION

The EPC9147B is an interface board that accepts the TI LAUNCHXL development kit, such as the F28379D, F28069M, or F280049 that features the TI C2000 microcontroller family, and connects to a compatible 3-phase eGaN® FET/ IC motor drive inverter board, as it can be seen in figure 1. This interface board allows users to utilize the existing TI InstaSPIN_UNIVERSAL GUI resources together with EPC- dedicated files to program the controller board and control a motor powered by an eGaN FET/IC 3-phase inverter using sensor-less field oriented control and space vector pulse width modulation.

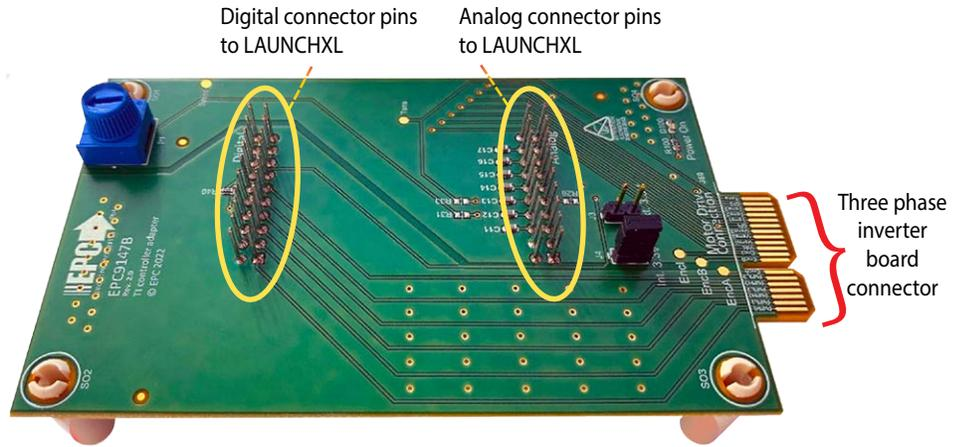

EPC9147B development board

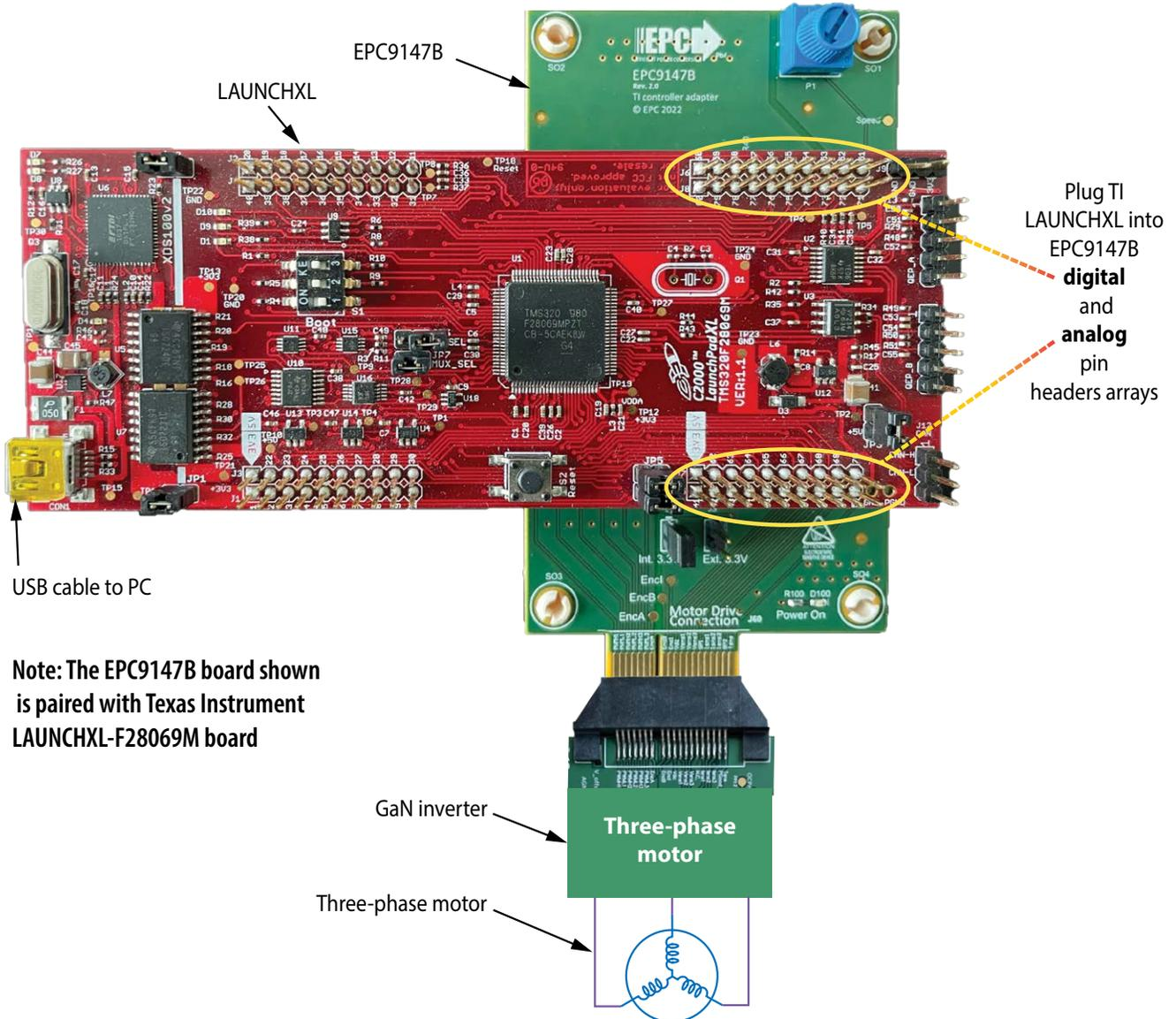

Note: The EPC9147B board shown is paired with Texas Instrument LAUNCHXL-F28069M board

Figure 1: EPC9147B matched with TI LAUNCHXL-F28069M

RECOMMENDED OPERATING CONDITIONS

The EPC9147B combined with Texas Instruments LAUNCHXL family of controllers is compatible with the following EPC motor drive inverter boards: EPC9146, EPC9167HC, EPC9173, EPC9176, and EPC9186.

The firmware provided requires to measure the phase voltages. The firmware can be modified in order to measure the temperature of the power board and to control the speed via the potentiometer present on the control board EPC9147B.

DETAILED DESCRIPTION OF THE EPC9147B BOARD

Figure 2 shows an overview of the EPC9147B board detailing connections such as mounting options and interfaces; and human interfaces that measures the dimensions of the board are: 110 x 60 mm (L x W).

On EPC9147B board

- Power LED
- Speed adjust knob
- Internal 3.3 V supply jumper
- External 3.3 V supply connector

On LAUNCHXL board

- Reset button
- Various jumpers

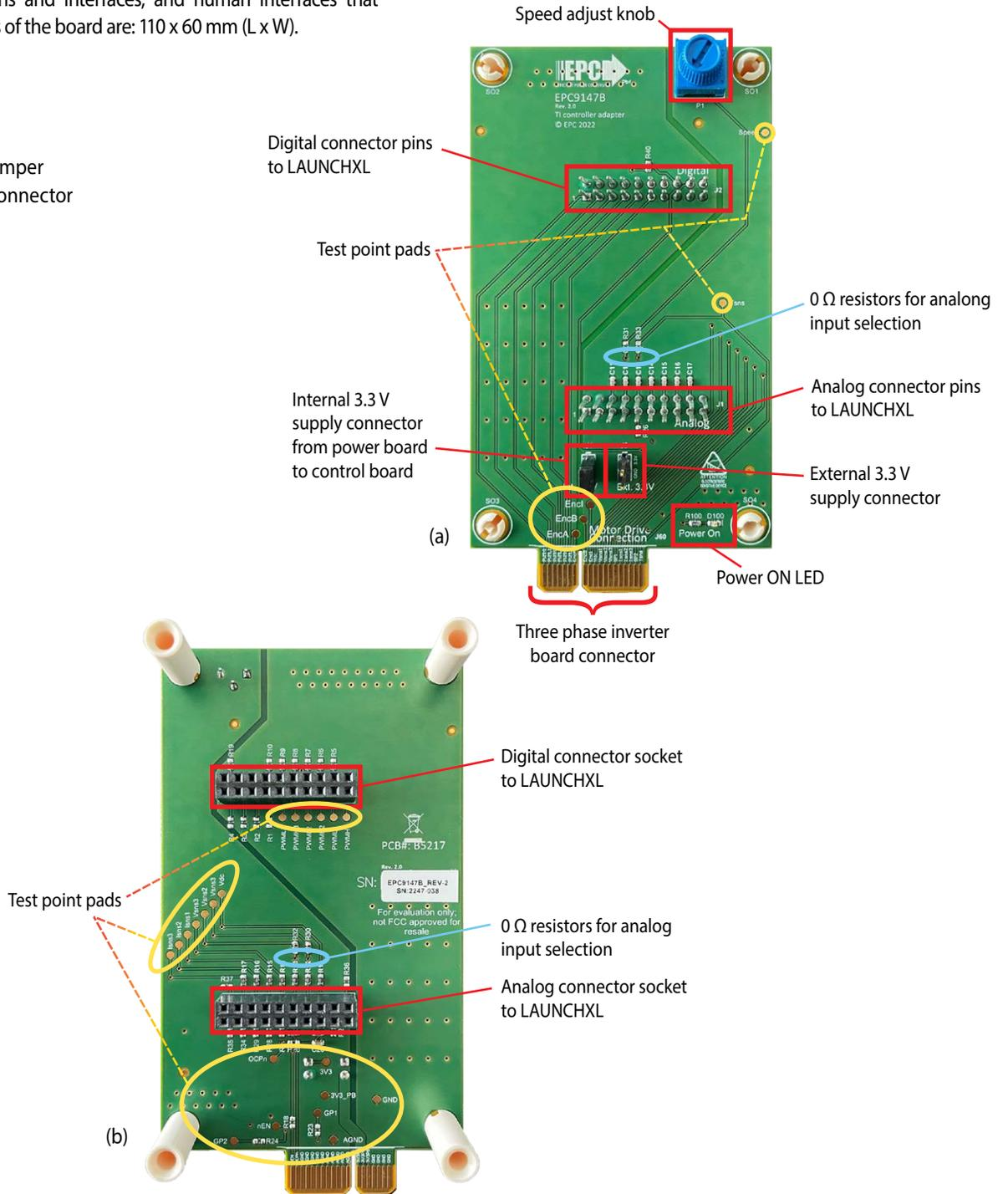

Figure 2: (a) EPC9147B top-side; (b) EPC9147B bottom-side

Test Points

Several test-points are available for measurement of various analog, error and PWM signals. Analog signals include voltage and current readings, input DC voltage to the drive, and current sense. The operator is encouraged to read the motor drive inverter drive QSG carefully to determine the correct scaling factors. The locations of the test points are shown in figure 3.

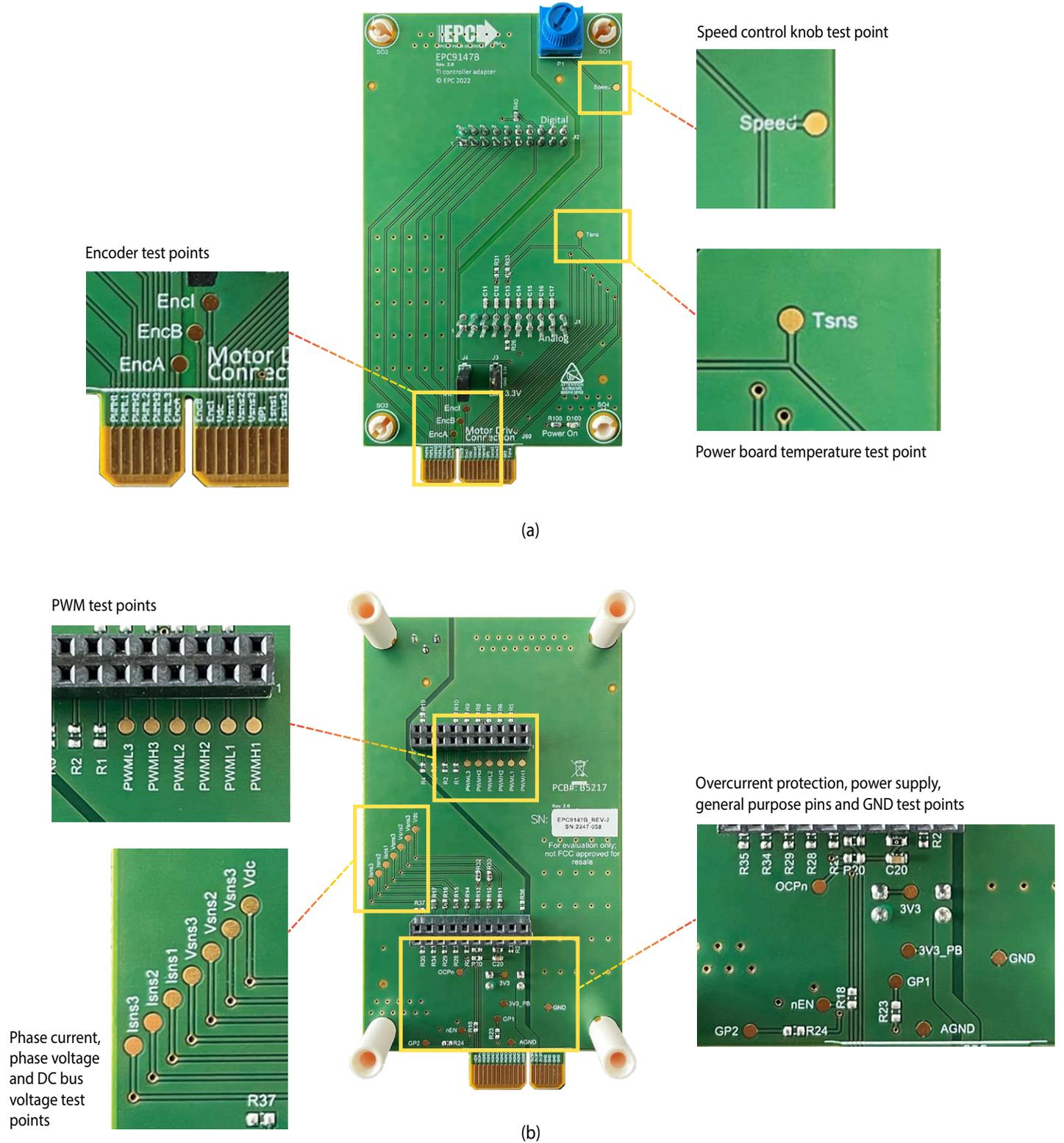

Figure 3: Test point locations (a) EPC9147B top-side; (b) EPC9147B bottom-side

Over-Current Detect

The EPC inverter boards are equipped with over-current detection circuits, but TI firmware does not provide over-current protection; contact Texas Instruments field-application engineers for firmware development support if over-current protection in control firmware is required.

0 Ω Resistors

Various 0 Ω resistors are that are present on the board that are used to send either phase voltages or other analog signals to the inputs of the ADC microcontroller. The default configuration is with phase voltage measurements. **Note that TI original firmware for LAUNCHXL uses measured phase voltages; to remove phase voltage measurements from ADC input, firmware needs to be modified.**

Place either R32 to measure the phase voltage of leg 2 or R33 to measure the temperature of the power board. Place either R30 to measure the phase voltage of leg 1 or R31 to have an analog signal from the on-board potentiometer to the ADC input.

Table 1

0 Ω resistor	Default configuration	Compatible with provided firmware	ADC I/O function
R30	Yes	Yes	Measure phase 1 voltage
R31	No	No, firmware needs changes	Measure signal from speed potentiometer
R32	Yes	Yes	Measure phase 2 voltage
R33	No	No, firmware needs changes	Measure temperature sensor on power board

Warning: The human interface controls and knob, as well as the entire EPC9147B, are not isolated. The EPC9147B is referenced to Power Ground and extreme caution has to be observed when operating the motor while the computer is attached to the EPC9147B via USB interface. It is recommended to use the opto-isolated USB communication option on the LAUNCHXL board to avoid damage to the computer.

CONNECTION DETAILS

Inverter

A 40 pin connector is used to interface power, PWM signals and analog feedback signals between the interface board and the motor drive inverter. Table 3 gives the map for each signal.

Table 2: Motor interface connection (J2) pin allocation map

Pin #	Pin Name		Pin #
2	PWMH1	GND	1
4	PWML1	GND	3
6	PWMH2	GND	5
8	PWML2	GND	7
10	PWMH3	3V3	9
12	PWML3	3V3	11
14	EncA	3V3	13
Index			
18	EncB	AGND	17
20	Encl	AGND	19
22	Vdc	AGND	21
24	Vsns1	AGND	23
26	Vsns2	AGND	25
28	Vsns3	AGND	27
30	GP1	AGND	29
32	Isns1	AGND	31
34	Isns2	AGND	33
36	Isns3	AGND	35
38	GP2	OCPn	37
40	Tsns	nEN	39

CONTROLLING A TEKNIC M-3411P-LN-08D MOTOR USING INSTASPIN UNIVERSAL GUI

The TI LAUNCHXL-F28069M board can be programmed using the InstaSPIN Universal GUI. The basic steps to run a Teknic motor Teknic_M-3411P-LN-08D using EPC inverter board-specific firmware and using the LAUNCH-XL-F28069M are explained below.

I. Download Texas Instruments Resources

1. Download the universal GUI from the following link: <https://www.ti.com/tool/INSTASPINUNIVERSALGUI>

- Make sure to be logged in with the personal profile on ti.com
- Make sure to select that the software will be used for civil use

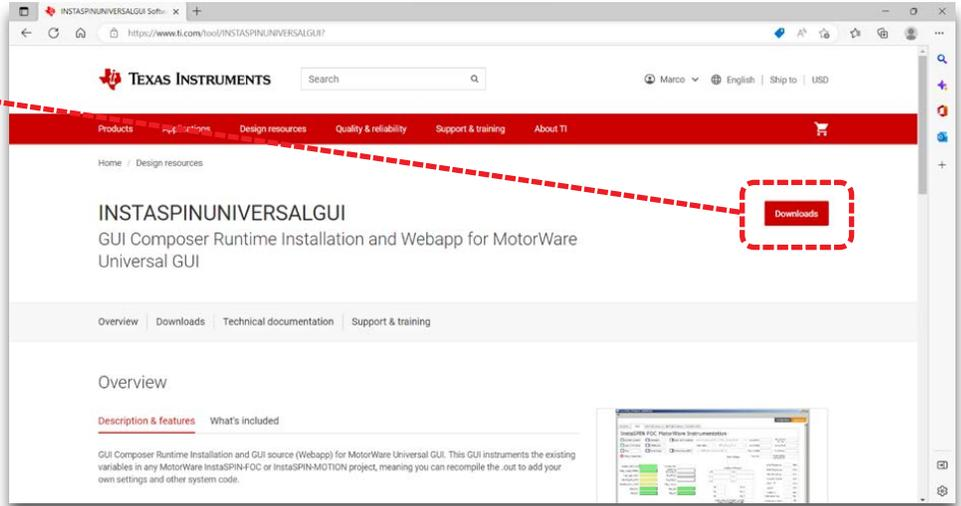

2. Execute the downloaded program `instaspinuniversalgui_v105.exe`

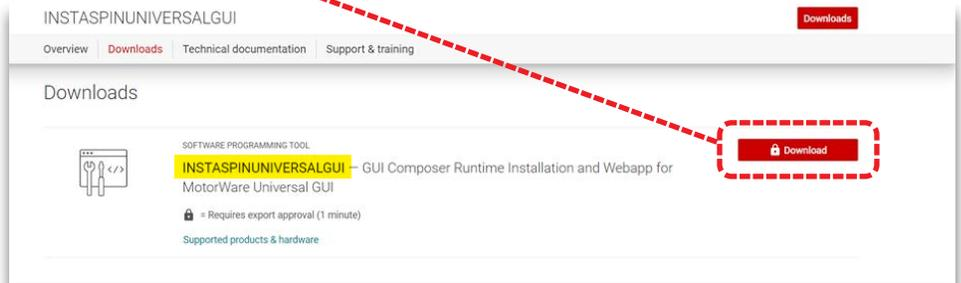

3. Follow all installations steps by accepting default settings.

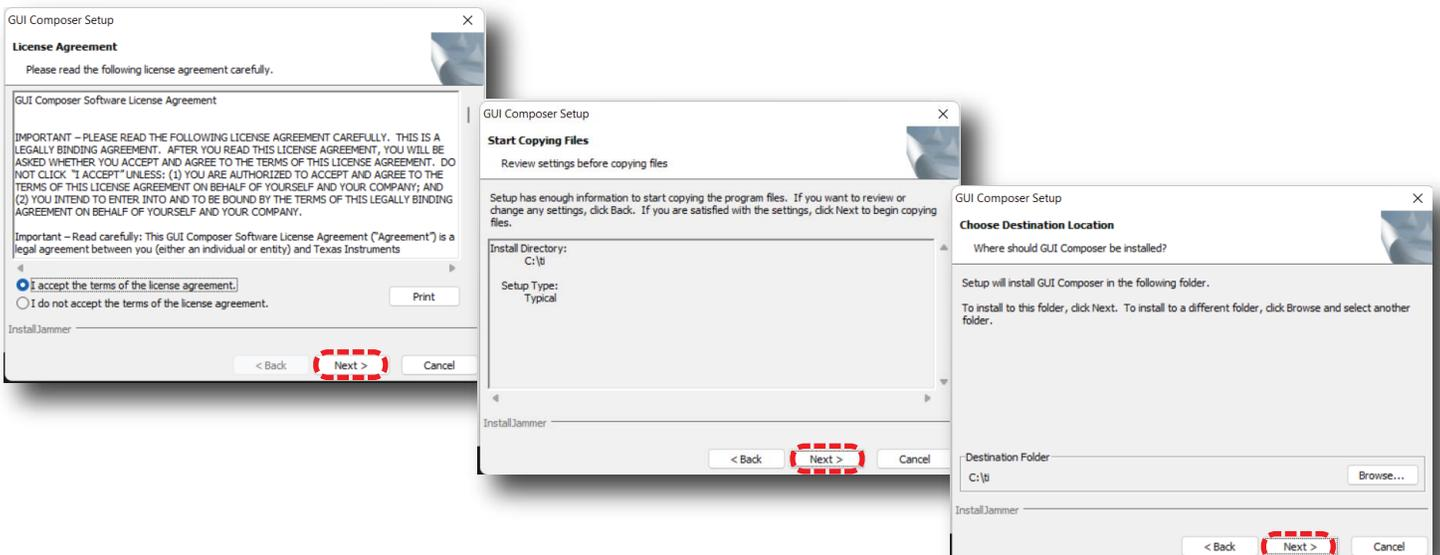

Spectrum Digital Emulator Drivers

During the GUI installation process, it may ask to install the drivers for the Spectrum Digital emulator. Click on Install button.

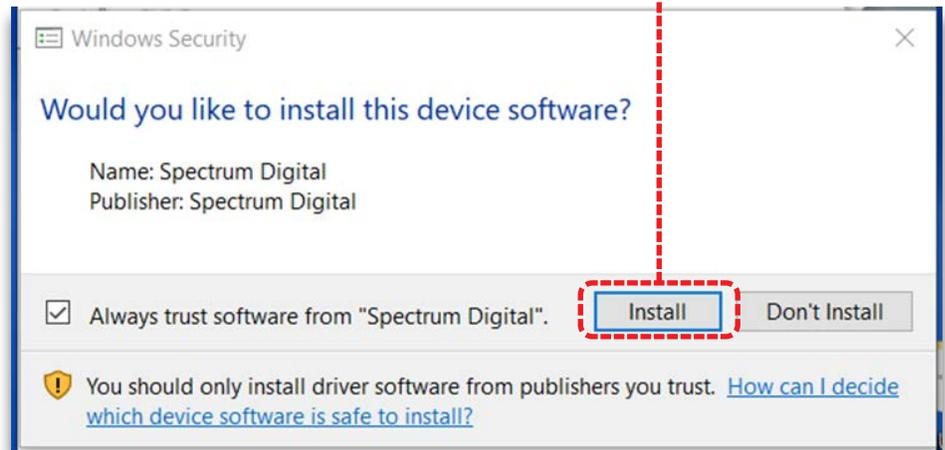

II. EPC 3-phase inverter board dedicated firmware

1. Download the EPC board dedicated files and store them in the correct location by clicking on the **"GitHub EPC Reference Design Firmware"** link on the [EPC9147B web page](#). 
2. **Install specific EPC directory in GUI software**
3. Navigate to the directory `C:\ti\guicomposer\webapps` and rename the directory `InstaSPIN_F2806xM_UNIVERSAL` by adding `_original` suffix.

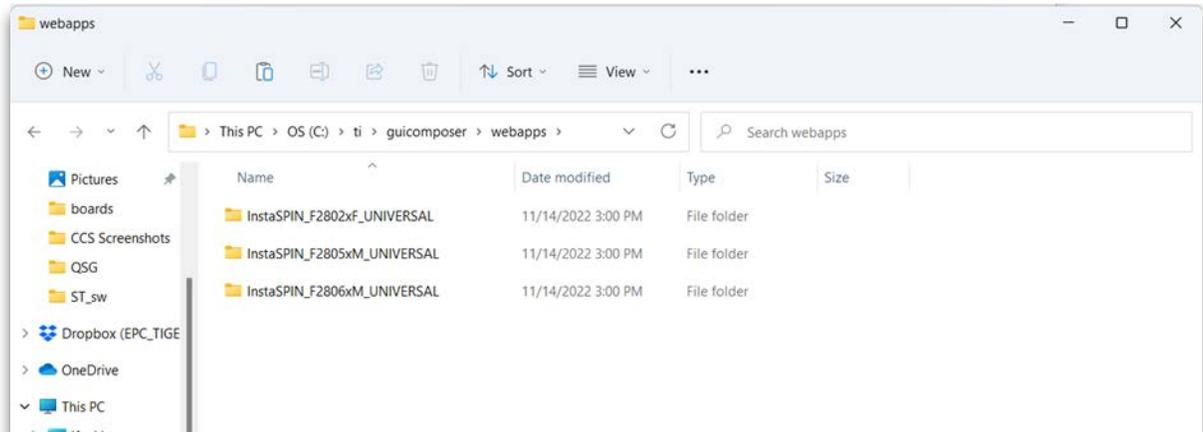

4. Download EPC power board firmware from **"GitHub EPC Reference Design Firmware"** link on the [EPC9147B web page](#),  then copy the directory `InstaSPIN_F2806xM_UNIVERSAL` supplied by EPC keeping the original name.

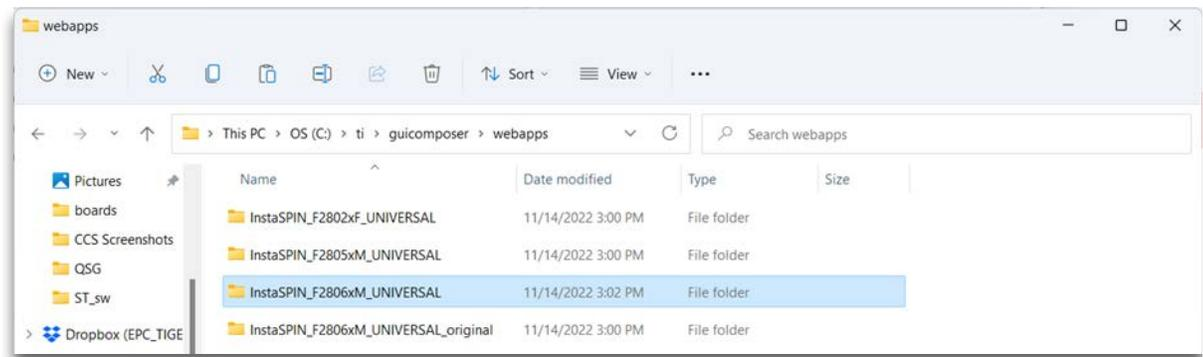

Enhance the Program DPI Resolution

Browse into the copied directory **InstaSPIN_F2806xM_UNIVERSAL** which was copied on the path: **c:\ti\guicomposer\webapps**. Right-click on the **InstaSPIN_UNIVERSAL.exe** program, choose **Properties** on the pop-up menu, then click on **Compatibility** tab and on the **Change high DPI settings** button.

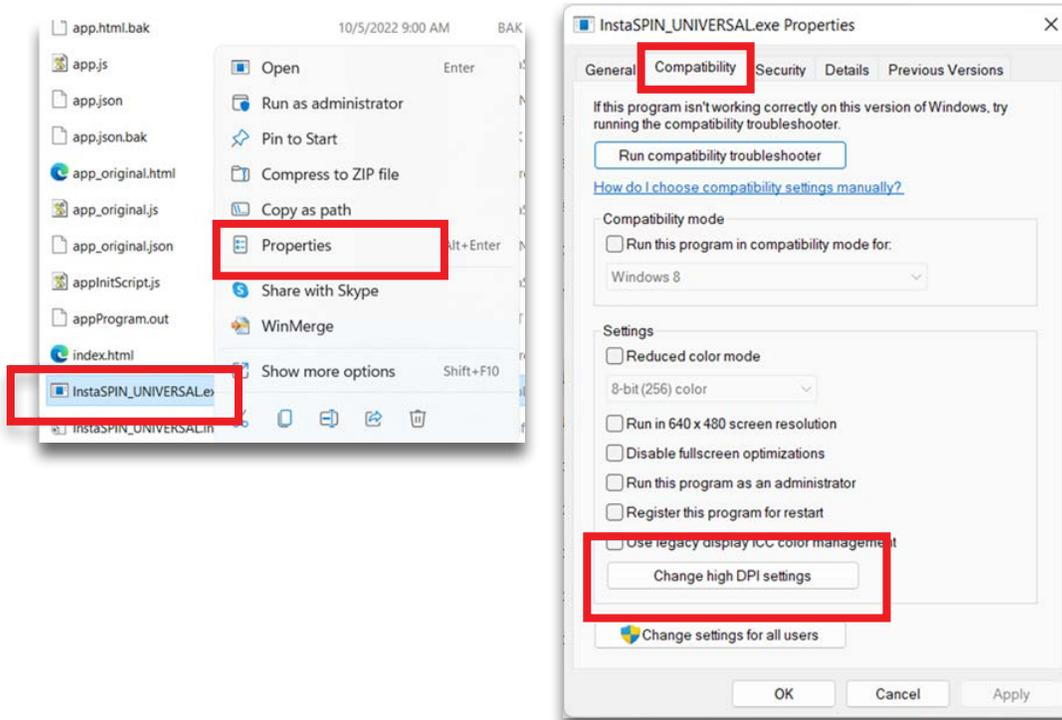

Tick **Override high DPI scaling behavior** and choose **System (Enhanced)** option, then press **OK**.

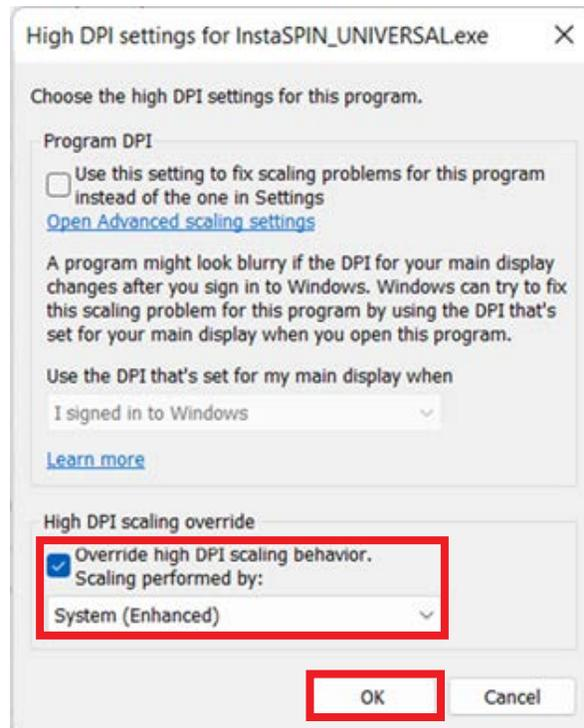

Preparing for the first launch

Each power board is associated with its specific file, but the software always executes the file named `appProgram.out`; so each time a power board is selected, the specific file associated with it should be copied and renamed `appProgram.out`. The step-by-step procedure is reported below.

1. Browse to `c:\ti\guicomposer\webapps\instaSPIN_F2806xM_UNIVERSAL`.
2. Inside the indicated directory, one file with `.out` extension for each motor drive reference design board is present.
3. Make sure to make a copy of the desired reference board `.out` file and then rename the copied file as `appProgram.out`.

HARDWARE connection check

4. Make sure that the EPC9147B + LaunchXL F28069M boards are connected to the USB port of the computer.
5. Launch the `InstaSPIN_UNIVERSAL.exe`

The `InstaSPIN_UNIVERSAL.exe` program looks for a file called `appProgram.out` and it downloads it on the RAM memory of the F28069M processor. Make sure to chose the proper `.out` file corresponding to the power board that is going to be used with the EPC9147B and rename the file with the name `appProgram.out`

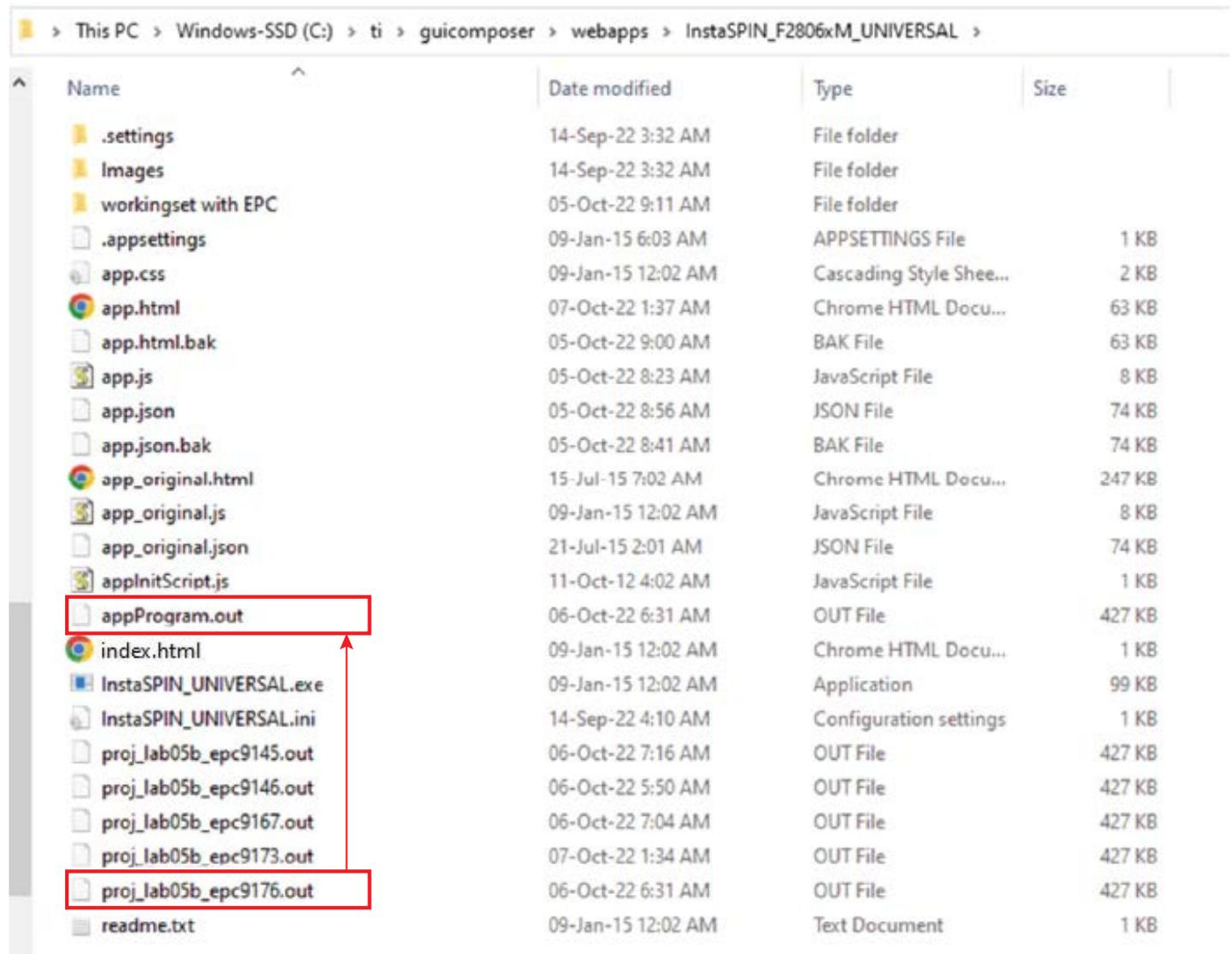

Name	Date modified	Type	Size
.settings	14-Sep-22 3:32 AM	File folder	
Images	14-Sep-22 3:32 AM	File folder	
workingset with EPC	05-Oct-22 9:11 AM	File folder	
.appsettings	09-Jan-15 6:03 AM	APPSETTINGS File	1 KB
app.css	09-Jan-15 12:02 AM	Cascading Style Shee...	2 KB
app.html	07-Oct-22 1:37 AM	Chrome HTML Docu...	63 KB
app.html.bak	05-Oct-22 9:00 AM	BAK File	63 KB
app.js	05-Oct-22 8:23 AM	JavaScript File	8 KB
app.json	05-Oct-22 8:56 AM	JSON File	74 KB
app.json.bak	05-Oct-22 8:41 AM	BAK File	74 KB
app_original.html	15-Jul-15 7:02 AM	Chrome HTML Docu...	247 KB
app_original.js	09-Jan-15 12:02 AM	JavaScript File	8 KB
app_original.json	21-Jul-15 2:01 AM	JSON File	74 KB
appInitScript.js	11-Oct-12 4:02 AM	JavaScript File	1 KB
appProgram.out	06-Oct-22 6:31 AM	OUT File	427 KB
index.html	09-Jan-15 12:02 AM	Chrome HTML Docu...	1 KB
InstaSPIN_UNIVERSAL.exe	09-Jan-15 12:02 AM	Application	99 KB
InstaSPIN_UNIVERSAL.ini	14-Sep-22 4:10 AM	Configuration settings	1 KB
proj_lab05b_epc9145.out	06-Oct-22 7:16 AM	OUT File	427 KB
proj_lab05b_epc9146.out	06-Oct-22 5:50 AM	OUT File	427 KB
proj_lab05b_epc9167.out	06-Oct-22 7:04 AM	OUT File	427 KB
proj_lab05b_epc9173.out	07-Oct-22 1:34 AM	OUT File	427 KB
proj_lab05b_epc9176.out	06-Oct-22 6:31 AM	OUT File	427 KB
readme.txt	09-Jan-15 12:02 AM	Text Document	1 KB

III. Using InstaSPIN Universal GUI

Setting Up the System

Before operating the board, the user must check that it is the correct reference design. The USB opto-isolator of the LaunchXL board must be enabled to continue.

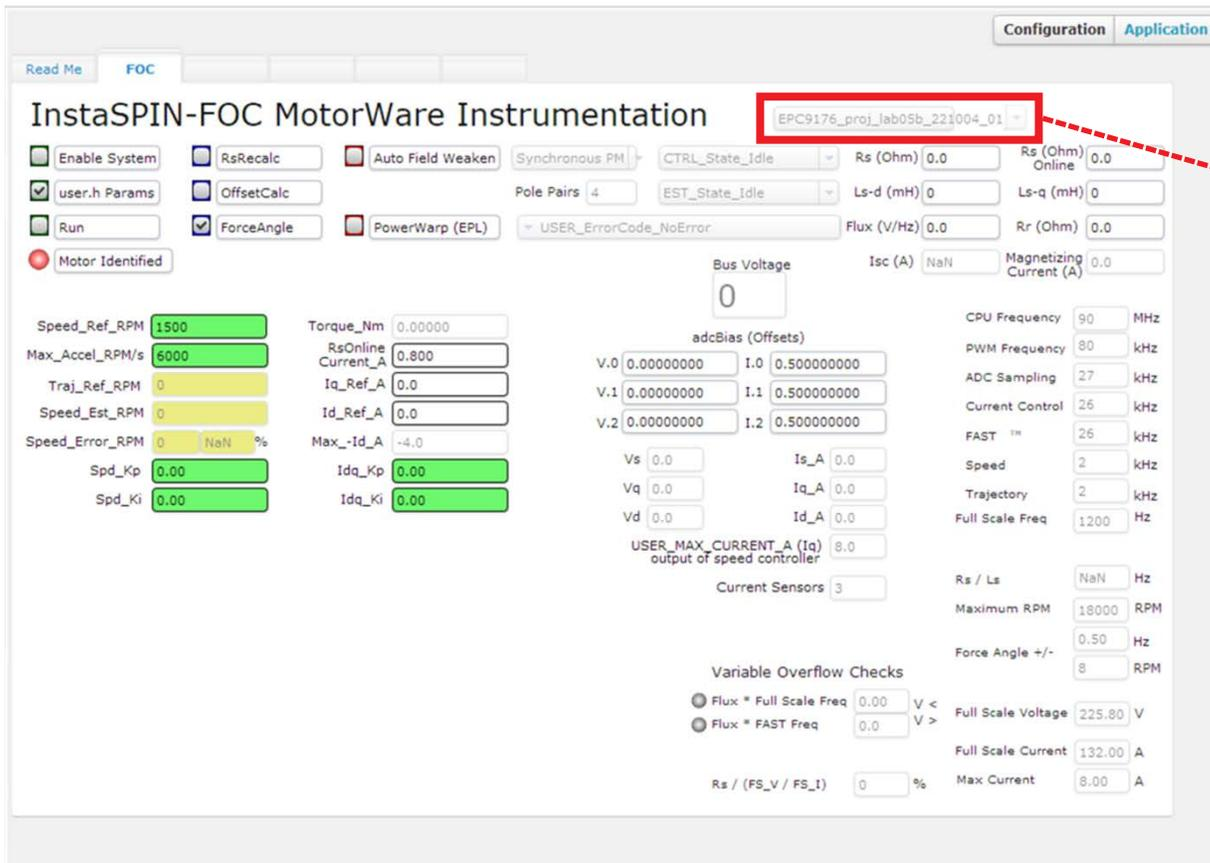

The reference design name is reflected here

Spinning the Teknic (default) Motor

Please note that this works only with the Teknic motor Teknic_M-3411P-LN-08D

The step-by-step procedure to spin the motor once the hardware connections are made and when the InstaSPIN UNIVERSAL GUI is launched are reported below.

1. Click on **Enable System**
2. Check that the value of the **Bus Voltage** corresponds to the applied DcBus voltage.
If the voltage is not corresponding, the most common problems are the following:
 - The power supply is not correctly set
 - The wrong **.out** file is used: the read voltage depends on the resistive divider on the power board
3. If the voltage is correct, the motor can be spinned by checking the **Run** box
4. The motor speed can be modified by changing the **Speed_Ref_RPM** value. Swapping the sign of the reference speed will command a change of spinning direction. As an example, if for positive reference speed values the motor spins clockwise, for negative reference speed values the motor spins counterclockwise.
5. The current loop and the speed loop parameters can be adjusted by changing the values indicated on the figure.
6. To stop the motor, uncheck the **Run** box.

Note: LAUNCHXL is not operating from Flash but from RAM so power cycling the board requires it to be reprogrammed.

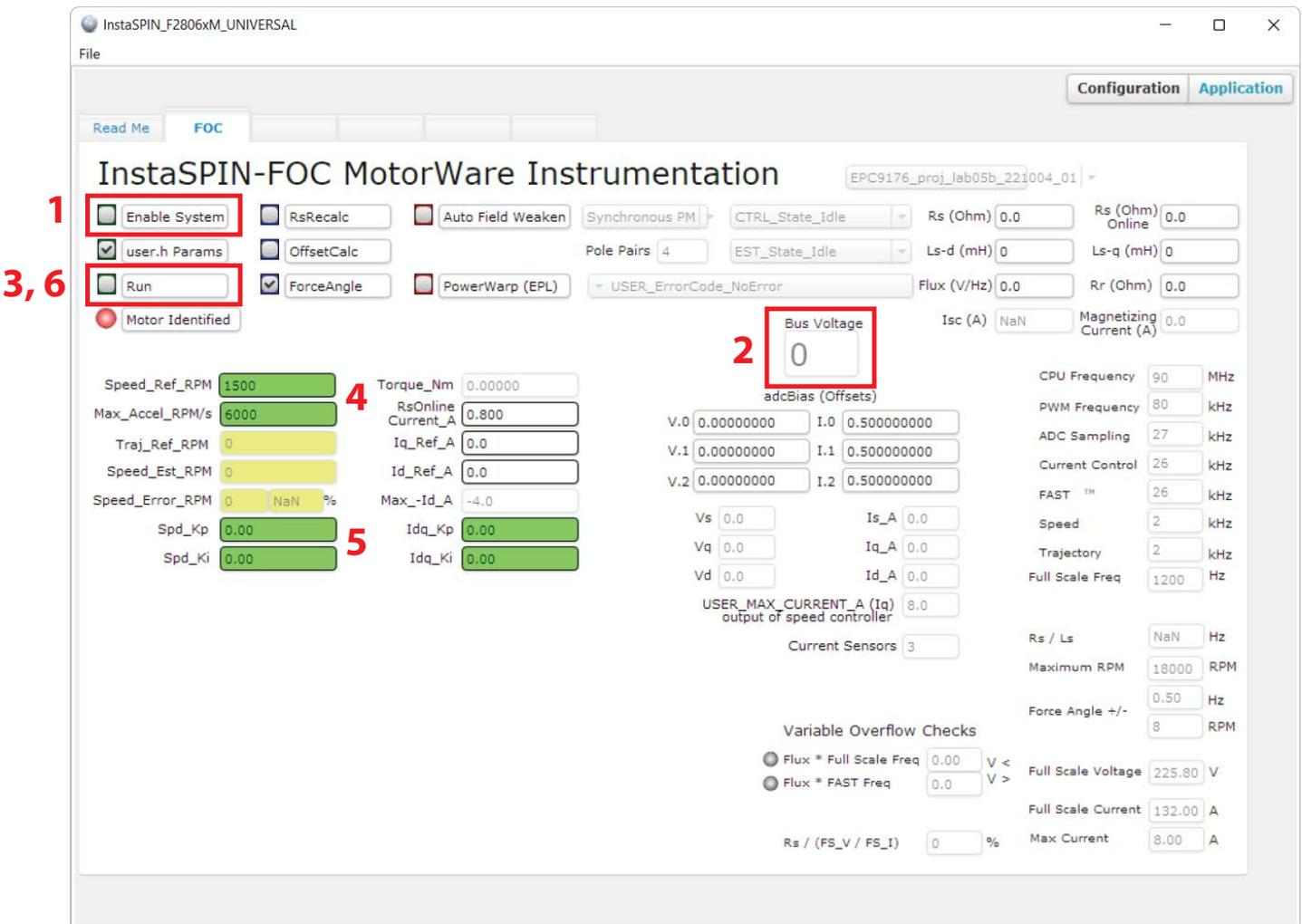

For More Information:

Please contact info@epc-co.com
or your local sales representative

Visit our website:
www.epc-co.com

Sign-up to receive
EPC updates at
bit.ly/EPCupdates



DigiKey

EPC Products are distributed through Digi-Key.
www.digikey.com

Demonstration Board Notification

The EPC9147B board is intended for product evaluation purposes only. It is not intended for commercial use nor is it FCC approved for resale. Replace components on the Evaluation Board only with those parts shown on the parts list (or Bill of Materials) in the Quick Start Guide. Contact an authorized EPC representative with any questions. This board is intended to be used by certified professionals, in a lab environment, following proper safety procedures. Use at your own risk.

As an evaluation tool, this board is not designed for compliance with the European Union directive on electromagnetic compatibility or any other such directives or regulations. As board builds are at times subject to product availability, it is possible that boards may contain components or assembly materials that are not RoHS compliant. Efficient Power Conversion Corporation (EPC) makes no guarantee that the purchased board is 100% RoHS compliant.

The Evaluation board (or kit) is for demonstration purposes only and neither the Board nor this Quick Start Guide constitute a sales contract or create any kind of warranty, whether express or implied, as to the applications or products involved.

Disclaimer: EPC reserves the right at any time, without notice, to make changes to any products described herein to improve reliability, function, or design. EPC does not assume any liability arising out of the application or use of any product or circuit described herein; neither does it convey any license under its patent rights, or other intellectual property whatsoever, nor the rights of others.