

Jul.1.2024 Copyright 2024 HIROSE ELECTRIC CO., LTD. All Rights Reserved.
In case of consideration for using Automotive equipment / device which demand high reliability, kindly contact our sales window correspondents.

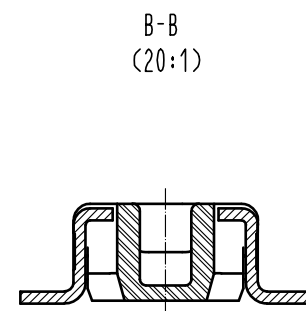

ENGAGEMENT FIGURE (20:1)

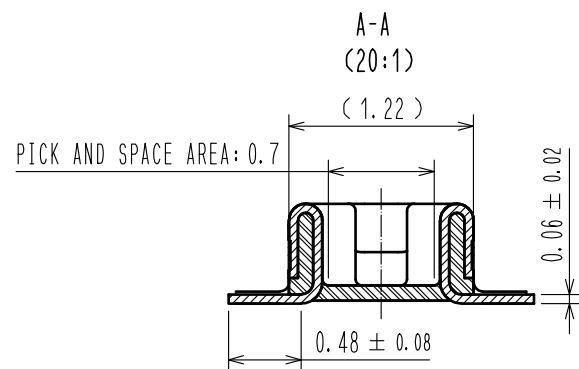
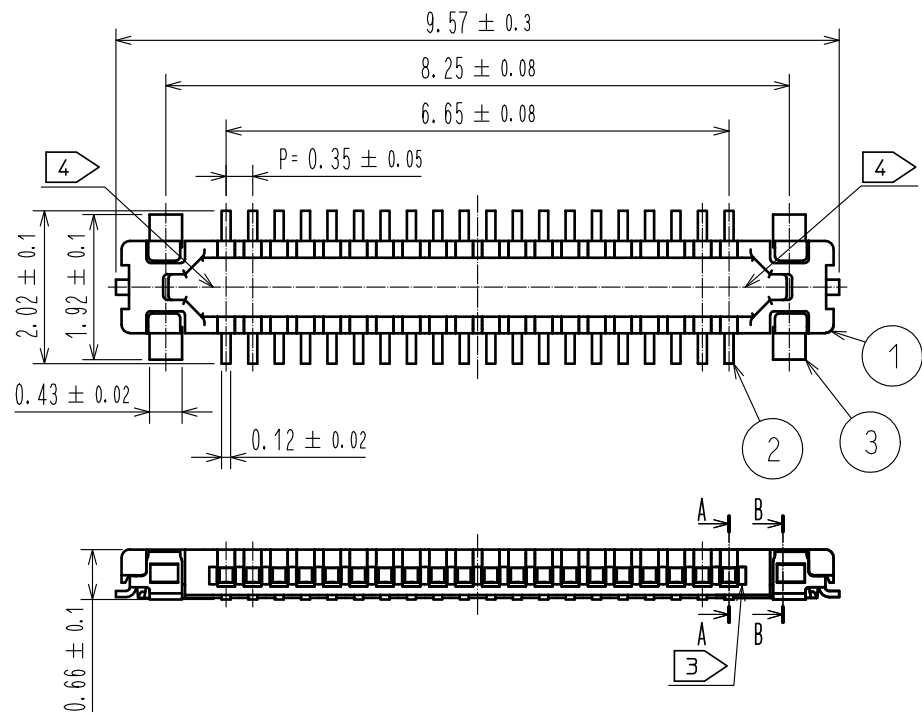
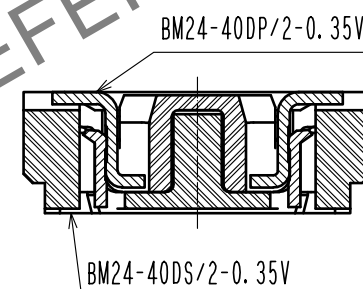
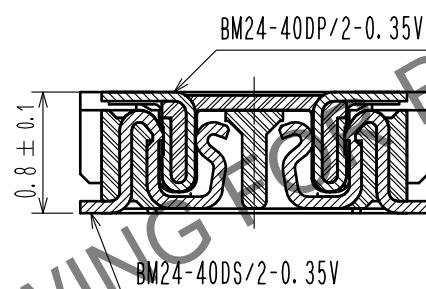

NOTE 1. ALL LEAD CO-PLANARITY SHALL BE 0.08mm MAX.

- 2 CONTACT PLATING SPECIFICATIONS
CONTACT AREA : GOLD 0.05 μm MIN
SMT LEAD : GOLD 0.05 μm MIN
UNDER PLATING : NICKEL 1 μm MIN
(SURFACE : SEALING)
- 3 A PART OF THE WALL COULD BE NOTCHED.
- 4 HRS MARK AND CAV No. ARE INDICATED IN APPROX. POSITION SHOWN.

◆ RECOMMENDED PCB LAYOUT

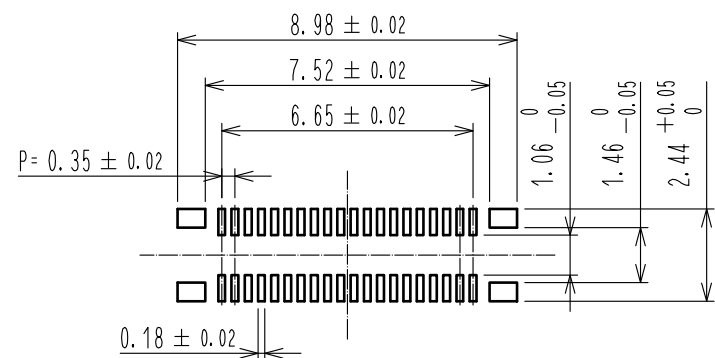

◆ RECOMMENDED METAL MASK DIMENSIONS
METAL MASK THICKNESS : 100 μm

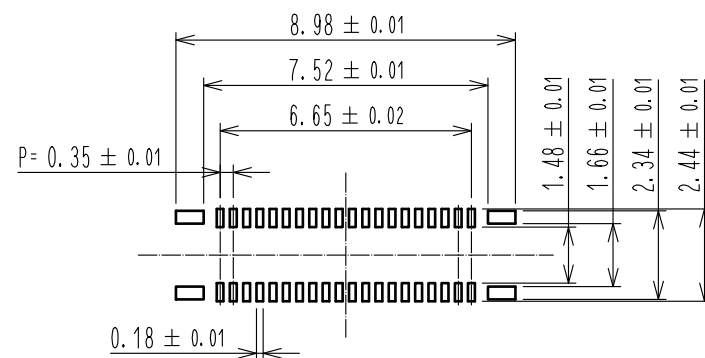

5 RECOMMENDED REFLOW TEMPERATURE PROFILE USING LEAD-FREE SOLDER PASTE.

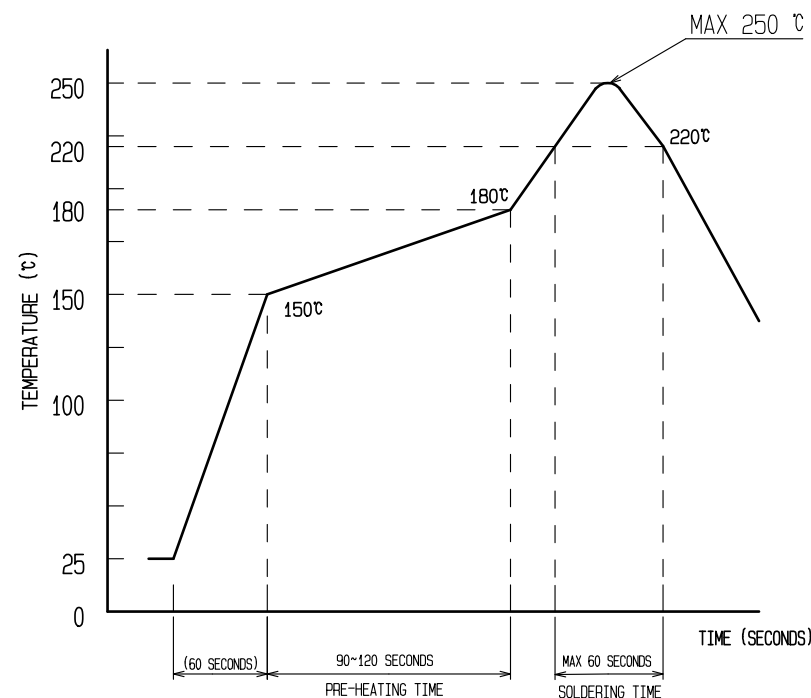

REFLOW METHOD: IR REFLOW
NUMBER OF REFLOW CYCLES: 2 CYCLES MAX.

- 1) REFLOW TIME
DURATION ABOVE 220°C, 60 SEC MAX.
(PEAK TEMPERATURE: 250°C MAX)
- 2) PRE-HEAT TIME
PRE-HEAT TEMPERATURE(MIN): 150°C
PRE-HEAT TEMPERATURE(MAX): 180°C
PRE-HEAT TIME: 90-120 SEC.

- 5 THIS TEMPERATURE PROFILE IS PER THE CONDITIONS SHOWN ABOVE. ADDITIONAL FACTORS, SUCH AS SOLDER PASTE TYPE, PCB SIZE AND OTHER MOUNTED COMPONENTS COULD AFFECT THE PROFILE. THEREFORE, A THOROUGH EVALUATION OF MOUNTING COONDITION IS REQUIRED PRIOR TO PRODUCTION. TEMPERATURE IS MEASURED AT CONTACT LEAD.
- 6. PLEASE CONTACT US IN CASE YOU WILL MAKE DIFFERENT SETTINGS FROM OUR RECOMMENDATION.

4	PS	CLEAR(EMBOSSED CARRIER TAPE)			
3	COPPER ALLOY	2	7	PS	CLEAR (REINFORCEMENT COLLAR)
2	PHOSPHOR BRONZE	2	6	PS	BLACK (PLASTIC REEL)
1	LCP	UL94 V-0. BLACK	5	POLYESTER	CLEAR (COVER TAPE)
NO.	MATERIAL	FINISH . REMARKS	NO.	MATERIAL	FINISH . REMARKS
UNITS	mm	SCALE	10 : 1	COUNT	DESCRIPTION OF REVISIONS
		DESIGNED	DATE		
APPROVED : MO. ISHIDA		15.12.14		DRAWING NO. EDC-357613-53-01	
CHECKED : TS. MIYAZAKI		15.12.14		PART NO. BM24-40DP/2-0.35V(53)	
DESIGNED : NY. YAMASHIRO		15.12.14		CODE NO. CL677-2009-0-53	
DRAWN : KR. AJITO		15.12.11		1/2	

Jul.1.2024 Copyright 2024 HIROSE ELECTRIC CO., LTD. All Rights Reserved.
 In case of consideration for using Automotive equipment / device which demand high reliability, kindly contact our sales window correspondents.

EMBOSSED CARRIER TAPE PACKAGING (FREE)

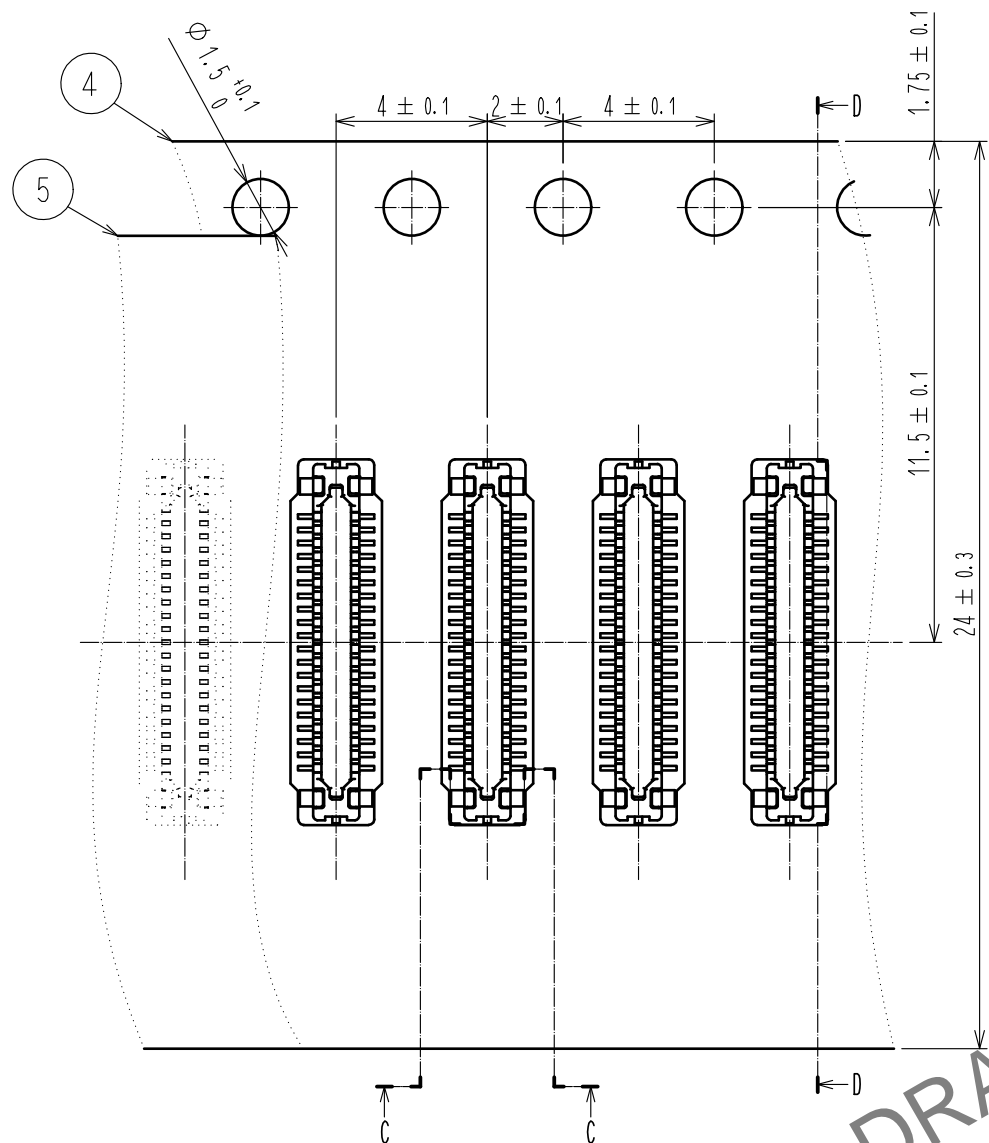

D-D(5:1)

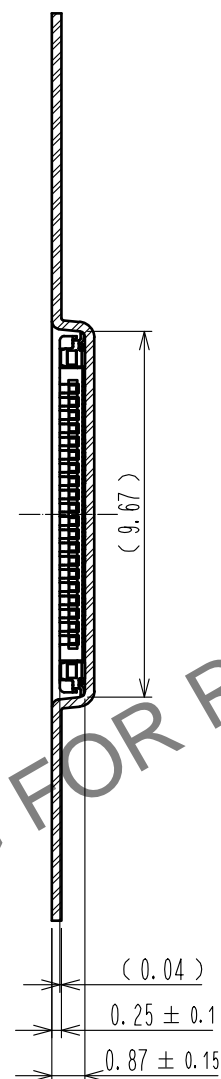

C-C (5:1)

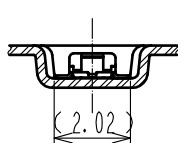

DIRECTION OF UNREELING

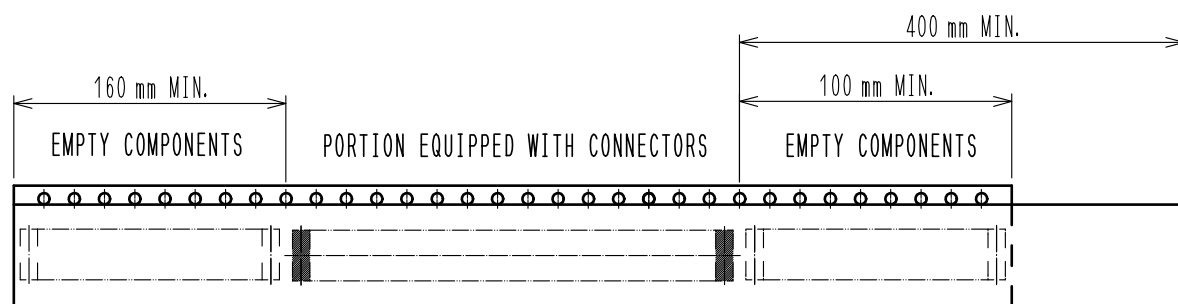
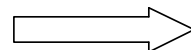

9 TAPING(FREE)

STYLE AND DIMENTION OF REEL (FREE)

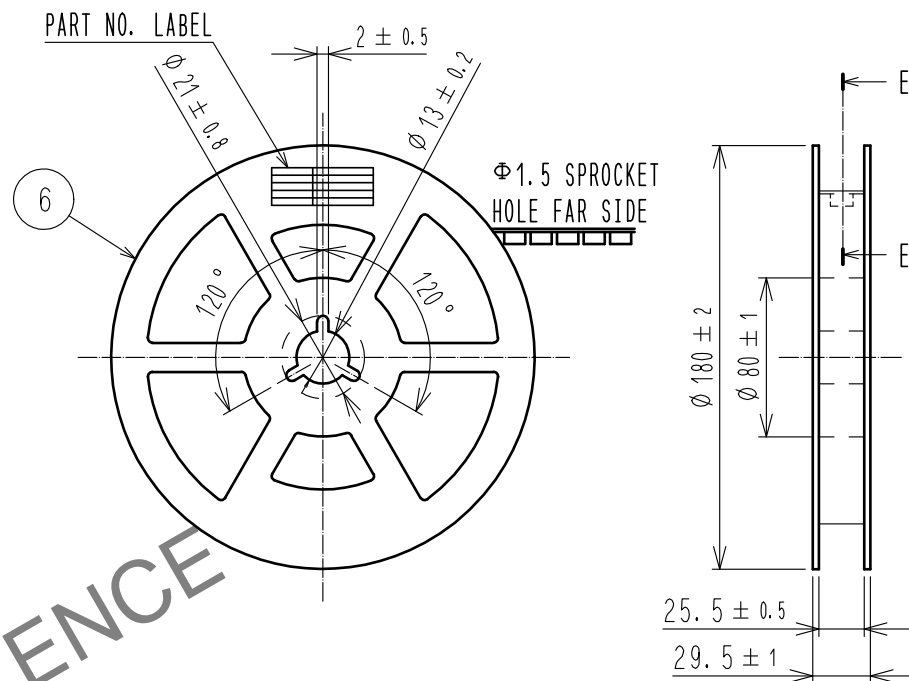

E-E (FREE)

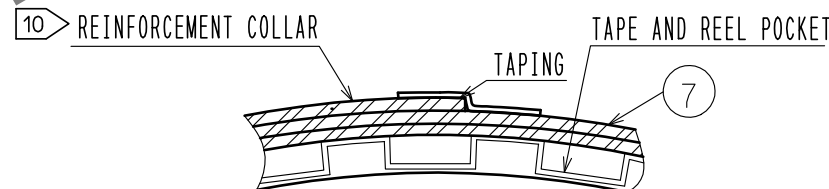

DETAIL OF PART NO. LABEL

製造年月日	** ** *
製品コード	CL0677-2009-0(53)
製品名	BM24-40DP/2-0.35V(53)
数量	1,000
納入者	ヒロセ電機(株)

DATA OF MANUFACTURED
 CODE NO.
 PART NO.
 QUANTITY
 SUPPLIER

- 7 . PER REEL 1,000 CONNECTORS.
- 8 . THE DIMENSIONS IN PARENTHESES ARE FOR REFERENCE.
- 9 . REFER TO JIS C 0806, IEC 60286-3(PACKAGING OF COMPONENTS FOR AUTOMATIC HANDLING)
- 10 . AFTER PACKAGING, ROLL 2 METERS OF THE REINFORCEMENT COLLAR TO OUTER CIRCUMFERENCE OF TAPE AND REEL POCKET, AND TAPE DOWN AT THE END THE COLLAR.

HRS	DRAWING NO.	EDC-357613-53-01
	PART NO.	BM24-40DP/2-0.35V(53)
	CODE NO.	CL677-2009-0-53
		△ 2/2