

THIS DRAWING IS UNPUBLISHED. RELEASED FOR PUBLICATION
 © COPYRIGHT - TE Connectivity Ltd. ALL RIGHTS RESERVED.

REVISIONS					
P	LTR	DESCRIPTION	DATE	DWN	APVD
	D	INTERNAL REVISION CHANGE	28JUN2018	SV	PKS

- CONTINUOUS STRIP ON REELS WITH TERMINALS LOCATED ON 8.38±0.08 [.330±.003] CENTERS.
- △ SLOT TERMINATES EITHER A SINGLE OR DOUBLE MAGNET WIRE OF THE SAME SIZE AND TYPE. COPPER RANGE: 1.29-1.45mm [#16-#15] AWG.
- AFTER INSERTION INTO PLASTIC HOLDER, TAB PORTION MUST BE BENT OVER 45° TO 90° OR POTTED-IN TO PREVENT PULL-OUT WHEN MATING RECEPTACLE IS DISCONNECTED.

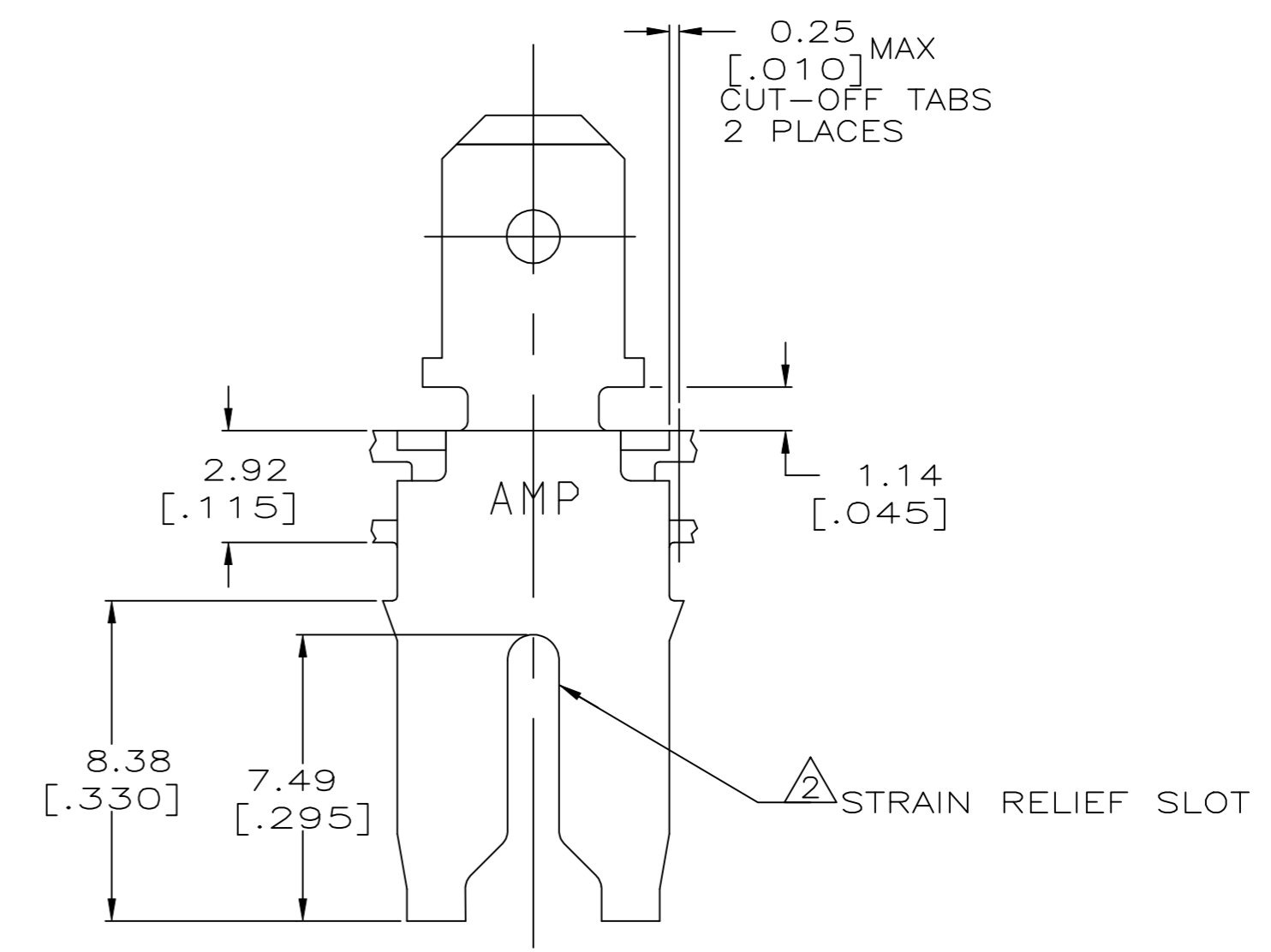
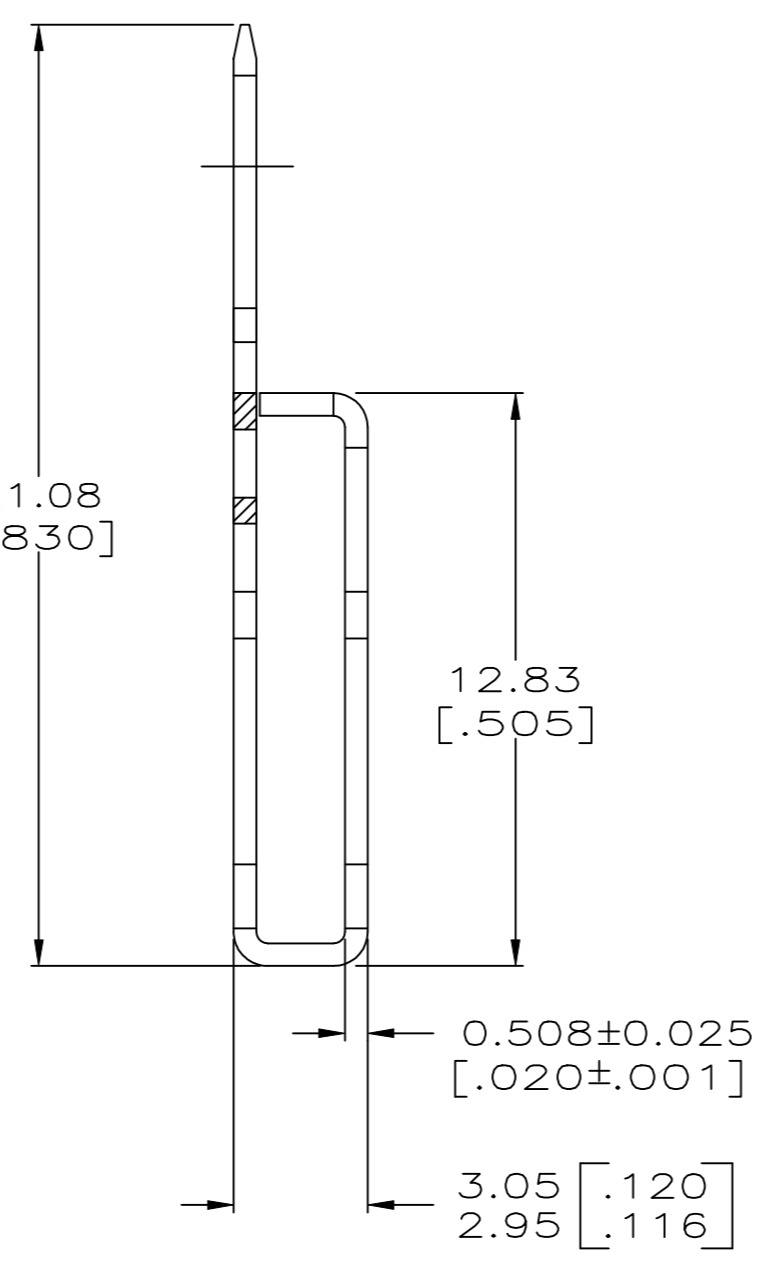
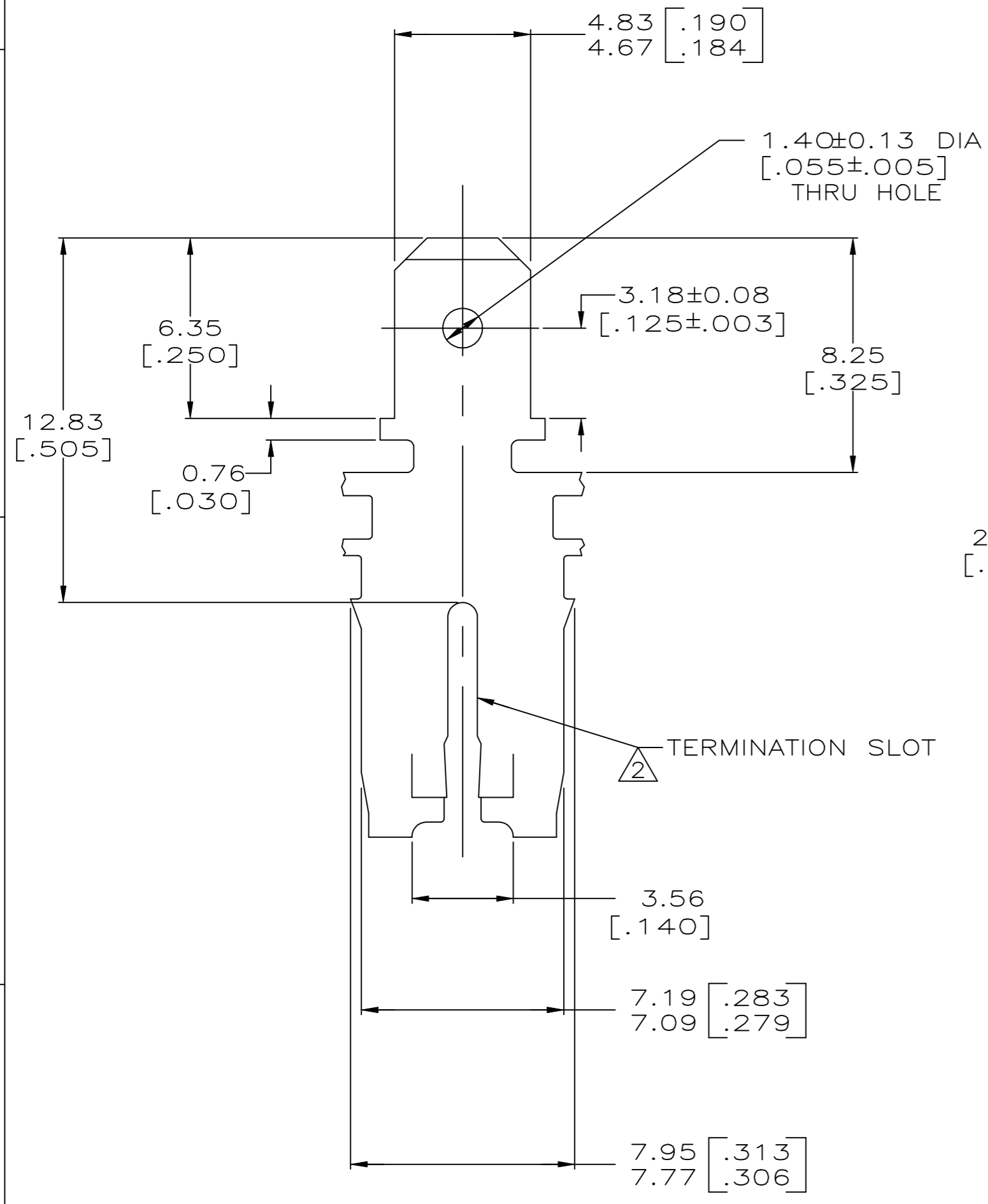
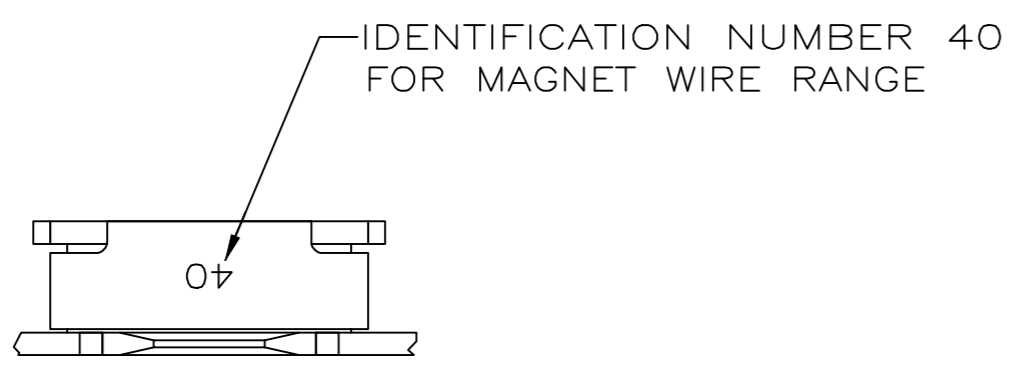

63996-1
PART NUMBER

THIS DRAWING IS A CONTROLLED DOCUMENT.		DWN MICHAEL S. FEHER 12JUN97	TE Connectivity	
DIMENSIONS: INCHES		CHK RICHARD GRZYBOWSKI 18JUN97	NAME NELSON E. NEFF 18JUN97	
TOLERANCES UNLESS OTHERWISE SPECIFIED:		APVD 108-2053 PRODUCT SPEC	TAB, 4.75[.187] FASTON, MAG-MATE™	
0 PLC ± -	1 PLC ± -	APPLICATION SPEC	SIZE A2	CAGE CODE 00779
2 PLC ± 0.25[.010]	3 PLC ± -	114-2066	DRAWING NO C=63996	RESTRICTED TO -
4 PLC ± -	ANGLES ± -	WEIGHT 0	SCALE 6:1	SHEET 1 of 1
MATERIAL BRASS	FINISH TIN PLATED	CUSTOMER DRAWING	REV D	